



A40i Datasheet

Intelligent Industrial Control Processor

Revision 1.1

Jun. 15, 2018

Revision History

Revision	Date	Description
1.0	May.22,2018	Initial Release Version.
1.1	Jun.15,2018	<p>Chapter 4 Pin Description Add some pin notes in Section 4.1. Add GPIO multiplex function in Section 4.2.</p> <p>Chapter 5 Electrical Characteristics Add SDRAM I/O DC electrical characteristics in Section 5.4. Add SDIO electrical parameters in Section 5.5. Add Audio Codec electrical characteristics in Section 5.6. Add SDRAM AC electrical characteristics in Section 5.11.1.</p> <p>Chapter 8 Carrier, Storage and Baking Information Add carrier, storage and baking information.</p> <p>Chapter 9 Reflow Profile Add FT and IQC test.</p> <p>Chapter 10 FT and IQC Test Add reflow profile.</p> <p>Chapter 11 Part Reliability Add part reliability.</p> <p>Chapter 12 Part Marking Add part marking.</p> <p>Chapter 13 Qualification Sample Description Add qualification sample description.</p>

Declaration

THIS DOCUMENTATION IS THE ORIGINAL WORK AND COPYRIGHTED PROPERTY OF ALLWINNER TECHNOLOGY ("ALLWINNER"). REPRODUCTION IN WHOLE OR IN PART MUST OBTAIN THE WRITTEN APPROVAL OF ALLWINNER AND GIVE CLEAR ACKNOWLEDGEMENT TO THE COPYRIGHT OWNER.

THE PURCHASED PRODUCTS, SERVICES AND FEATURES ARE STIPULATED BY THE CONTRACT MADE BETWEEN ALLWINNER AND THE CUSTOMER. PLEASE READ THE TERMS AND CONDITIONS OF THE CONTRACT AND RELEVANT INSTRUCTIONS CAREFULLY BEFORE USING, AND FOLLOW THE INSTRUCTIONS IN THIS DOCUMENTATION STRICTLY. ALLWINNER ASSUMES NO RESPONSIBILITY FOR THE CONSEQUENCES OF IMPROPER USE(INCLUDING BUT NOT LIMITED TO OVERVOLTAGE, OVERCLOCK, OR EXCESSIVE TEMPERATURE).

THE INFORMATION FURNISHED BY ALLWINNER IS PROVIDED JUST AS A REFERENCE OR TYPICAL APPLICATIONS, ALL STATEMENTS, INFORMATION, AND RECOMMENDATIONS IN THIS DOCUMENT DO NOT CONSTITUTE A WARRANTY OF ANY KIND, EXPRESS OR IMPLIED. ALLWINNER RESERVES THE RIGHT TO MAKE CHANGES IN CIRCUIT DESIGN AND/OR SPECIFICATIONS AT ANY TIME WITHOUT NOTICE.

NOR FOR ANY INFRINGEMENTS OF PATENTS OR OTHER RIGHTS OF THE THIRD PARTIES WHICH MAY RESULT FROM ITS USE. NO LICENSE IS GRANTED BY IMPLICATION OR OTHERWISE UNDER ANY PATENT OR PATENT RIGHTS OF ALLWINNER. THIRD PARTY LICENCES MAY BE REQUIRED TO IMPLEMENT THE SOLUTION/PRODUCT. CUSTOMERS SHALL BE SOLELY RESPONSIBLE TO OBTAIN ALL APPROPRIATELY REQUIRED THIRD PARTY LICENCES. ALLWINNER SHALL NOT BE LIABLE FOR ANY LICENCE FEE OR ROYALTY DUE IN RESPECT OF ANY REQUIRED THIRD PARTY LICENCE. ALLWINNER SHALL HAVE NO WARRANTY, INDEMNITY OR OTHER OBLIGATIONS WITH RESPECT TO MATTERS COVERED UNDER ANY REQUIRED THIRD PARTY LICENCE.

Contents

1. Overview	14
2. Features.....	15
2.1. CPU Architecture.....	15
2.2. GPU Architecture	15
2.3. Memory Subsystem.....	15
2.4. System Peripheral.....	16
2.5. Video Engine	17
2.6. Display Subsystem.....	18
2.7. Image In.....	19
2.8. Audio Subsystem.....	19
2.9. External Peripherals	20
2.10. Package	22
3. Block Diagram	23
4. Pin Description	25
4.1. Pin Characteristics.....	25
4.2. GPIO Multiplex Function	52
4.3. Signal Descriptions	56
5. Electrical Characteristics	64
5.1. Absolute Maximum Ratings	64
5.2. Recommended Operating Conditions	65
5.3. DC Electrical Characteristics.....	66
5.4. SDRAM I/O DC Electrical Characteristics.....	66
5.5. SDIO Electrical Parameters.....	66
5.6. Audio Codec Electrical Parameters	67
5.7. KEYADC Electrical Characteristics	69

5.8. PLL Electrical Characteristics	69
5.8.1. CPU PLL Electrical Parameters.....	69
5.8.2. Audio PLL Electrical Parameters.....	69
5.8.3. GPU PLL Electrical Parameters	69
5.8.4. Peripheral0/1 PLL Electrical Parameters.....	69
5.8.5. MIPI PLL Electrical Parameters.....	70
5.8.6. DDR0/1 PLL Electrical Parameters	70
5.8.7. Video0/1 PLL Electrical Parameters.....	70
5.8.8. VE PLL Electrical Parameters	70
5.8.9. DE PLL Electrical Parameters	71
5.8.10. SATA PLL Electrical Parameters.....	71
5.9. Oscillator Electrical Characteristics	71
5.10. Maximum Current Consumption	72
5.11. External Memory Electrical Characteristics.....	72
5.11.1. SDRAM AC Electrical Characteristics	72
5.11.2. Nand AC Electrical Characteristics.....	76
5.11.3. SMHC AC Electrical Characteristics	81
5.12. External Peripherals Electrical Characteristics	81
5.12.1. LCD AC Electrical Characteristics	81
5.12.2. CSI AC Electrical Characteristics	83
5.12.3. EMAC AC Electrical Characteristics	85
5.12.4. PS2 AC Electrical Characteristics	85
5.12.5. CIR AC Electrical Characteristics	87
5.12.6. SPI AC Electrical Characteristics	87
5.12.7. UART AC Electrical Characteristics	88
5.12.8. TWI AC Electrical Characteristics.....	89
5.12.9. TSC AC Electrical Characteristics	89
5.12.10. AC97 AC Electrical Characteristics.....	90

- 5.12.11. SCR AC Electrical Characteristics92
- 5.13. Power-up and Power-down Sequence 93
- 6. Package Thermal Characteristics..... 95
- 7. Pin Assignment..... 96
 - 7.1. Pin Map 96
 - 7.2. Package Dimension97
- 8. Carrier, Storage and Baking Information 98
 - 8.1. Carrier 98
 - 8.1.1. Matrix Tray Information 98
 - 8.2. Carrier 99
 - 8.2.1. Matrix Tray Information 99
 - 8.2.2. Bagged Storage Conditions 100
 - 8.2.3. Out-of-bag Duration 100
 - 8.3. Baking..... 100
- 9. Reflow Profile 101
- 10. FT and IQC Test..... 103
 - 10.1. FT Test 103
 - 10.2. IQC Test 103
 - 10.2.1. QA Test 103
 - 10.2.2. QC Test 103
- 11. Part Reliability 104
- 12. Part Marking..... 105
- 13. Qualification Sample Description 106

Figures

Figure 3-1. A40i Block Diagram	23
Figure 3-2. A40i Application Diagram	24
Figure 5-1. SDIO Voltage Waveform	67
Figure 5-2. DDR3/DDR3L Command and Address Timing.....	72
Figure 5-3. DDR3/DDR3L Write Cycle	73
Figure 5-4. DDR3/DDR3L Read Cycle	73
Figure 5-5. LPDDR3 Command and Address Timing Diagram.....	74
Figure 5-6. LPDDR3 Write Cycle	74
Figure 5-7. LPDDR3 Read Cycle	75
Figure 5-8. LPDDR2 Command and Address Timing Diagram.....	75
Figure 5-9. LPDDR2 Write Cycle	76
Figure 5-10. LPDDR2 Read Cycle	76
Figure 5-11. Conventional Serial Access Cycle Timing (SAM0)	77
Figure 5-12. EDO Type Serial Access after Read Cycle Timing (SAM1)	77
Figure 5-13. Extending EDO Type Serial Access Mode Timing (SAM2).....	77
Figure 5-14. Command Latch Cycle Timing.....	78
Figure 5-15. Address Latch Cycle Timing.....	78
Figure 5-16. Write Data to Flash Cycle Timing.....	78
Figure 5-17. Waiting R/B# Ready Timing	79
Figure 5-18. WE# High to RE# Low Timing.....	79
Figure 5-19. RE# High to WE# Low Timing.....	79
Figure 5-20. Address to Data Loading Timing	80
Figure 5-21. SMHC in SDR Mode Output Timing	81
Figure 5-22. SMHC in SDR Mode Input Timing	81
Figure 5-23. HV_IF Interface Vertical Timing	82

Figure 5-24. HV_IF Interface Parallel Mode Horizontal Timing	82
Figure 5-25. HV_IF Interface Serial Mode Horizontal Timing	83
Figure 5-26. 8/10/12-bit CMOS Sensor Interface Timing.....	83
Figure 5-27. 16-bit YCbCr4:2:2 with Separate Sync Timing	84
Figure 5-28. 8-bit YCbCr4:2:2 with Embedded Syncs(BT656) Timing	84
Figure 5-29. Data Sample Timing	84
Figure 5-30. EMAC MII Interface Transmit Timing.....	85
Figure 5-31. EMAC MII Interface Receive Timing.....	85
Figure 5-32. PS2 Timing for Master Transmit Data and Device Receive Data	86
Figure 5-33. PS2 Timing for Device Transmit Data and Master Receive Data	86
Figure 5-34. PS2 Timing for Master Sending Command then Device Sending Response	86
Figure 5-35. CIR-RX Timing.....	87
Figure 5-36. SPI MOSI Timing.....	87
Figure 5-37. SPI MISO Timing.....	87
Figure 5-38. UART RX Timing	88
Figure 5-39. UART nCTS Timing.....	88
Figure 5-40. UART nRTS Timing.....	88
Figure 5-41. TWI Timing	89
Figure 5-42. TSC Data and Clock Timing.....	89
Figure 5-43. AC97 Cold Reset Timing	90
Figure 5-44. AC97 Warm Reset Timing	90
Figure 5-45. AC-link Low Power Mode Timing.....	90
Figure 5-46. BIT_CLK and SYNC Timing	90
Figure 5-47. AC-link Data Transmission Output and Input Timing.....	91
Figure 5-48. Signal Rise and Fall Timing	91
Figure 5-49. SCR Activation and Cold Reset Timing	92
Figure 5-50. SCR Warm Reset Timing.....	93
Figure 5-51. A40i Power Up Sequence.....	94

Figure 7-1. A40i Pin Map.....	96
Figure 7-2. A40i Package Dimension.....	97
Figure 8-1. Tray Dimension Drawing.....	99
Figure 9-1. Typical Lead-free Reflow Profile	101
Figure 9-2. Measuring the Reflow Soldering Process	102
Figure 12-1. A40i Marking.....	105

Tables

Table 4-1. Pin Characteristics	26
Table 4-2. GPIO Multiplex Function	52
Table 4-3. Signal Descriptions	57
Table 5-1. Absolute Maximum Ratings	64
Table 5-2. Recommended Operating Conditions.....	65
Table 5-3. DC Electrical Characteristics.....	66
Table 5-4. DC Input Logic Level	66
Table 5-5. Output DC Current Drive.....	66
Table 5-6. 3.3V SDIO Electrical Parameters	67
Table 5-7. 1.8V SDIO Electrical Parameters	67
Table 5-8. Audio Codec Typical Performance	67
Table 5-9. KEYADC Electrical Characteristics.....	69
Table 5-10. CPU PLL Electrical Parameters	69
Table 5-11. Audio PLL Electrical Parameters.....	69
Table 5-12. GPU PLL Electrical Parameters	69
Table 5-13. Peripheral0/1 PLL Electrical Parameters.....	70
Table 5-14. MIPI PLL Electrical Parameters.....	70
Table 5-15. DDR0/1 PLL Electrical Parameters	70
Table 5-16. Video0/1 PLL Electrical Parameters	70
Table 5-17. VE PLL Electrical Parameters.....	70
Table 5-18. DE PLL Electrical Parameters.....	71
Table 5-19. SATA PLL Electrical Parameters.....	71
Table 5-20. 24MHz Crystal Characteristics	71
Table 5-21. 32768Hz Crystal Characteristics.....	72
Table 5-22. DDR3/DDR3L Timing Parameters.....	72

Table 5-23. DDR3/DDR3L Write Cycle Parameters	73
Table 5-24. DDR3/DDR3L Read Cycle Parameters	73
Table 5-25. LPDDR3 Command and Address Timing Parameters	74
Table 5-26. LPDDR3 Write Cycle Parameters.....	74
Table 5-27. LPDDR3 Read Cycle Parameters.....	75
Table 5-28. LPDDR2 Command and Address Timing Parameters	75
Table 5-29. LPDDR2 Write Cycle Parameters.....	76
Table 5-30. LPDDR2 Read Cycle Parameters.....	76
Table 5-31. NAND Timing Constants	80
Table 5-32. SMHC Timing Constants	81
Table 5-33. LCD HV_IF Interface Timing Constants.....	83
Table 5-34. CSI Interface Timing Constants	84
Table 5-35. 100Mb/s MII Transmit Timing Constants.....	85
Table 5-36. 100Mb/s MII Receive Timing Constants	85
Table 5-37. PS2 Timing Constants	86
Table 5-38. CIR-RX Timing Constants	87
Table 5-39. SPI Timing Constants	87
Table 5-40. UART Timing Constants	88
Table 5-41. TWI Timing Constants	89
Table 5-42. TSC Timing Constants.....	89
Table 5-43. AC97 Timing Constants	91
Table 5-44. SCR Timing Constants.....	93
Table 6-1. A40i Thermal Resistance Characteristics	95
Table 8-1. Matrix Tray Carrier Information.....	98
Table 8-2. Packing Quantity Information	98
Table 8-3. MSL Summary	99
Table 8-4. Bagged Storage Conditions	100
Table 8-5. Out-of-bag Duration.....	100

Table 9-1. Lead-free Reflow Profile Conditions	101
Table 11-1. Package Reliability Results	104
Table 11-2. Silicon Reliability Results.....	104
Table 12-1. A40i Marking Definitions.....	105

About This Documentation

Purpose

The documentation describes features of each module, pin/signal characteristics, current consumption, PLL electrical characteristics, the interface timing, thermal and package of A40i processor. The documentation is intended to provide guidance to the hardware designers for electronics or sales personnel for electronic components. This documentation assumes that the reader has a background in electronic components. For details about register descriptions of each module, see the *A40i User Manual*.

Intended Audience

The document is intended for:

- Hardware designers and maintenance personnel for electronics
- Sales personnel for electronic parts and components

Conventions

Symbol Conventions

The symbols that may be found in this document are defined as follows.



Symbol	Description
 WARNING	A warning means that injury or death is possible if the instructions are not obeyed.
 CAUTION	A caution means that damage to equipment is possible.
 NOTE	Provides additional information to emphasize or supplement important points of the main text.

Table Content Conventions

The table content conventions that may be found in this document are defined as follows.

Symbol	Description
-	The cell is blank.

Numerical Conventions

The expressions of data capacity, frequency, and data rate are described as follows.

Type	Symbol	Value
Data capacity	1K	1024
	1M	1,048,576
	1G	1,073,741,824
Frequency, data rate	1k	1000
	1M	1,000,000
	1G	1,000,000,000

1. Overview

The A40i processor represents Allwinner's latest achievement in intelligent industrial control processors. The processor is ideal for applications that require 3D graphics, advanced video processing, rich user interfaces, lower power consumption and higher system integration.

The A40i processor has some very exciting features:

- **CPU:** A40i is based on quad-core Cortex™-A7 CPU architecture, the most power efficient CPU core ARM's ever developed.
- **GPU:** A40i adopts the extensively implemented and technically mature Mali400 MP2 to provide mobile users with superior experience in web browsing, video playback and games.
- **Video Engine:** Supports mainstream high-definition video decoding including H.264, H.263, MPEG1/2/4, xvid, Sorenson Spark, VP6, VP8, AVS/AVS+, WMV7, WMV8 by 1080p@60fps. In the aspect of video encoding, the A40i supports 1080p@45fps H.264 encoding ability.
- **Camera:** Supports dual CMOS sensor parallel interfaces and 4-channel TVIN , which can easily finish multi-channel video recording.
- **Display:** Content can be displayed on 4-lane MIPI DSI displays, or RGB panel, or LVDS panel.TV-out on HDMI V1.4 is also supported.
- **Audio:** Integrated audio codec with 24bit/192kHz DAC playback, and supports I2S/PCM interface for connecting to an external audio codec.I2S/PCM interface includes eight channels of TDM with sampling precision up to 32bit/192kHz.
- **Memory:** Supports external memory interfaces to NAND Flash, SD/eMMC, Nor Flash and SDRAM port. SDRAM port can be configured to support LPDDR2, LPDDR3, DDR2, DDR3, DDR3L.
- **Peripherals:** To reduce total system cost, A40i has a broad range of hardware peripherals to meet the flexible peripheral configuration requirements such as UART, RTP, SPI, CIR, USB2.0 OTG, TWI etc.

2. Features

2.1. CPU Architecture

- Quad-core ARM Cortex™-A7 Processor
- ARMv7 ISA standard ARM instruction set
- Thumb-2 Technology
- Jazeller RCT
- NEON Advanced SIMD
- VFPv4 floating point
- Large Physical Address Extensions(LPAE)
- 32KB L1 Instruction cache and 32KB L1 Data cache for per CPU
- 512KB L2 cache shared

2.2. GPU Architecture

- Mali400 MP2
- Supports OpenGL ES 2.0 ,OpenGL ES 1.1, Open VG 1.1 standard

2.3. Memory Subsystem

Boot ROM

- On-chip 36KB ROM boot loader
- Supports fast boot from NAND Flash, eMMC, SD/TF card and SPI Nor Flash
- Supports system code download through USB OTG
- Boot select pin(FEL) is used to select system boot method: boot from USB when FEL is low level, or else enter into fast boot process

SDRAM

- Compatible with JEDEC standard DDR2/DDR3/DDR3L/LPDDR2/LPDDR3 SDRAM
- Up to 2GB address space
- 32-bit data bus width
- DDR3/DDR3L interface with the maximum frequency of 576MHz
- LPDDR3 interface with the maximum frequency of 480MHz
- LPDDR2 interface with the maximum frequency of 432MHz

NAND Flash

- Compliant with ONFI 2.3 and Toggle 1.0
- Up to 64-bit ECC per 512 bytes or 1024 bytes
- Supports 1K/2K/4K/8K/16KB page size
- Up to 8-bit data bus width

- Supports 8 chip selects, and 2 ready_busy signals
- Supports SLC/MLC NAND and EF-NAND
- Supports SDR/Toggle DDR/ONFI DDR NAND interface

SMHC

- Up to four SMHC controllers
- Compatible with eMMC standard specification V5.0, SD physical layer specification V3.0 ,SDIO card specification V2.0
- 1/4/8-bit bus width
- Embedded special DMA to do data transfer
- Supports hardware CRC generation and error detection
- Supports block size of 1 to 65535 bytes

2.4. System Peripheral

Timer

- 6 Timers
- Two 33-bit AVS counters to synchronize video and audio in the player
- One watchdog to generate reset signal or interrupt
- External 24MHz or 32768Hz crystal oscillator input

High Speed Timer

- 4 High Speed Timers
- Clock source is fixed to AHBCLK, and the pre-scale ranges from 1 to 16
- 56-bit counter that can be separated to 24-bit high register and 32-bit low register

RTC

- Timer, Calendar, Alarm
- Supports full clock features: second/minute/hour/day/month/year(with leap year)

GIC

- Supports 16 SGIs(Software Generated Interrupt), 16 PPIs(Private Peripheral Interrupt) and 101 SPIs(Shared Peripheral Interrupts)
- Supports ARM architecture security extensions
- Supports ARM architecture virtualization extensions

DMA

- 16 channels
- Interrupt generated for each DMA channel
- Transfers data width of 8/16/32/64-bit
- Supports linear and IO address modes
- Programs the DMA burst size

- Flexible data source and destination address generation
- Supports data transfer types with memory-to-memory, memory-to-peripheral, peripheral-to-memory

CCU

- 13 PLLs, one external 24MHz oscillator, one external 32768Hz oscillator, an on-chip RC oscillator
- Supports clock configuration and clock generated for corresponding modules
- Supports software-controlled clock gating and software-controlled reset for corresponding modules

PWM

- 8 PWM channels outputs(4 PWM pairs)
- Supports capture input
- Supports three kinds of output waveforms: continuous waveform, pulse waveform and complementarity pair
- Programmable deadzone generator and controllable dead-time
- 0% to 100% adjustable duty cycle
- Up to 24/100MHz output frequency
- Minimum resolution is 1/65536
- Supports interrupt for PWM output and capture input

Thermal Sensor

- Temperature Accuracy : $\pm 3^{\circ}\text{C}$ from 0°C to $+100^{\circ}\text{C}$, $\pm 5^{\circ}\text{C}$ from -20°C to $+125^{\circ}\text{C}$
- Supports over-temperature protection interrupt and over-temperature alarm interrupt
- Averaging filter for thermal sensor reading
- Supports 2 sensors: sensor0 for CPU, sensor1 for GPU

Crypto Engine

- Supports symmetrical algorithm: AES, DES, 3DES
- Supports hash algorithm: MD5, SHA1, SHA224, SHA256, SHA384, SHA512, HMAC
- Supports asymmetrical algorithm: RSA512, RSA1024, RSA2048
- Supports 160-bit hardware PRNG with 175-bit seed
- Supports 256-bit hardware TRNG
- AES mode: ECB, CBC, CTR, CTS, OFB, CFB
- DES/3DES mode: ECB, CBC, CTR

Security ID

- One on-chip efuse
- Size up to 2Kbit for security chip ID
- Supports on-line LDO programming

2.5. Video Engine

Video Decoder

- Supports video decoding up to 1080p@60fps

- Supports multi-formats:
 - MPEG1 MP/HL: 1080p@60fps
 - MPEG2 MP/HL: 1080p@60fps
 - MPEG4 SP/ASP L5: 1080p@60fps
 - H.263 BP: 1080p@60fps
 - H.264 BP/MP/HP Level4.2: 1080p@60fps
 - xvid: 1080p@60fps
 - Sorenson Spark: 1080p@60fps
 - VP6 6.0/6.1/6.2: 1080P@60fps
 - VP8: 1080p@60fps
 - AVS/AVS+ JiZhun: 1080p@60fps
 - WMV7/WMV8: 1080p@60fps
 - WMV9/VC-1 SP/MP/AP: 1080p@60fps
 - JPEG: 16384 x 16384@45MPPS

Video Encoder

- H.264 HP encoding up to 1080p@45fps
- JPEG baseline: picture size up to 4096x4096
- Supports H.264 encoding input formats:NV12/NV21/YUV420SP,YUV422SP/NV16,NU12/NV21/YVU420SP, YVU422SP/NV61, 32 x 32 tile-based,128 x 32 tile-based,ARGB8888,RGBA8888,ABGR8888,BGRA8888, YU12/YUV420P,YV12/YVU420P,YU16/YUV422P,YV16/YVU422P,raw YUYV422,raw UYVY422,raw YVYU422,raw VYUY422
- Supports JPEG encoding input formats:YUV420/YUV422/YUV444
- Alpha blending
- Thumb generation
- 4x2 scaling ratio from 1/16 to 64 arbitrary non-integer ratio

2.6. Display Subsystem

DE2.0

- Supports output size up to 2048 x 2048
- Supports four alpha blending channels for main display, two channels for aux display
- Supports four overlay layers in each channel, and has an independent scaler
- Supports potter-duff compatible blending operation
- Supports motion-adaptive de-interlace for 480i, 576i and 1080i inputs
- Supports input format YUV422/YUV420/YUV411/ARGB8888/XRGB8888/RGB888/ARGB4444/ARGB1555 and RGB565
- Supports Frame Packing/Top-and-Bottom/Side-by-Side Full/Side-by-Side Half 3D format data
- Supports SmartColor2.0 for excellent display experience
 - Adaptive edge sharpening
 - Adaptive color enhancement
 - Adaptive contrast enhancement and fresh tone rectify
- Supports SmartColor2.0 for excellent display experience

Video Output

- Supports HDMI 1.4 transmitter with HDCP 1.2, up to 1080p@60fps
- Supports 4 lanes MIPI DSI up to 1080p@60fps
- Supports LVDS interface up to 1920 x 1080@60fps
- Supports RGB interface up to 1920 x 1080@60fps
- Supports TV output, including 4-ch CVBS, 1-ch YPbPr and 1-ch VGA

2.7. Image In

- Supports TV decoder: 4-ch analog CVBS or 1-ch YPbPr(480i/576i/480p/576p) signal input
- Dual CMOS sensor parallel interfaces :CSI0 and CSI1
 - Supports 8-bit YUV422 CMOS sensor interface and 8-bit BT656 interface for each CSI
 - Supports CCIR656 protocol for each CSI
 - Supports 16-bit BT1120 interface for CSI0
 - Supports 24-bit RGB/YUV444 input for CSI1
 - Supports multi-channel ITU-R BT.656 time-multiplexed format for CSI0
 - CSI0 supports still capture resolution up to 5M,and video capture resolution up to 1080p@30fps
 - CSI1 supports still capture resolution up to 5M,and video capture resolution up to 720p@30fps

2.8. Audio Subsystem

Audio Codec

- Two audio digital-to-analog(DAC) channels
 - Up to 100±3dB SNR during DAC playback
 - Supports DAC sample rate from 8kHz to 192kHz
 - Supports 16-bit and 24-bit audio sample resolution
- Two audio analog-to-digital(ADC) channels
 - Up to 93±3dB SNR during ADC capture
 - Supports ADC sample rate from 8kHz to 48kHz
 - Supports 16-bit and 24-bit audio sample resolution
- Four audio inputs:
 - Two mono microphone inputs
 - One stereo Line-in input
 - One stereo FM-in input
- Two audio outputs:
 - One differential PHONEOUT output
 - One stereo headphone output
- Supports analog/digital volume control
- Supports dynamic range controller adjusting the DAC playback and ADC capture

I2S/PCM

- Up to two I2S/PCM interfaces
- Compliant with standard Philips Inter-IC sound(I2S) bus specification
- Compliant with left-justified, right-justified, PCM mode, and TDM(Time Division Multiplexing) format
- Full-duplex synchronous work mode
- Master and slave mode configured
- Adjustable audio sample resolution from 8-bit to 32-bit
- Sample rate from 8kHz to 192kHz
- Supports 8-bit u-law and 8-bit A-law companded sample
- Supports programmable PCM frame width:1 BCLK width(short frame) and 2 BCLKs width(long frame)

One Wire Audio(OWA)

- IEC-60958 transmitter functionality
- Compatible with S/PDIF protocol

- Supports channel status insertion for the transmitter
- Hardware Parity generation on the transmitter
- One 32x24 bits TX FIFO for audio data transfer
- Programmable FIFO thresholds

AC97

- Compliant with AC97 2.3 component specification
- Full-duplex synchronous serial interface
- Up to 48kHz sampling rate
- Channels support mono or stereo samples of 16(standard),18(optional) and 20(optional) bit wide
- Supports DRA mode

2.9. External Peripherals

USB

- USB 2.0 OTG, with integrated one USB 2.0 analog PHY
 - Compatible with USB2.0 Specification
 - Support High-Speed(HS,480 Mbit/s),Full-Speed(FS,12 Mbit/s),and Low-Speed(LS,1.5 Mbit/s) in host mode
 - Supports High-Speed (HS, 480 Mbit/s), Full-Speed (FS, 12 Mbit/s) in device mode
 - Up to 8 user-configurable endpoints for Bulk , Isochronous, Control and Interrupt(Endpoint1, Endpoint2, Endpoint3, Endpoint4)
- Two USB Hosts, with integrated two USB 2.0 analog PHY
 - Compatible with Enhanced Host Controller Interface(EHCI)Specification, Version 1.0, and the Open Host Controller Interface(OHCI) Specification, Version 1.0a.

EMAC

- Compliant with IEEE 802.3 standard
- Supports 10/100Mbps data transfer rate
- Supports MII PHY interface
- Supports full and half duplex operations

GMAC

- Compliant with the IEEE 802.3-2002 standard
- Programmable frame length to support Standard or Jumbo Ethernet frames with size up to 16KB
- Supports 10/100/1000Mbit/s data transfer rates
- Supports MII/RGMII PHY interface
- Supports a variety of flexible address filtering modes
- Supports full and half duplex operations

Transport Stream Controller

- Up to 2 Transport Stream Controllers
- One external Synchronous Parallel Interface(SPI) and one external Synchronous Serial Interface(SSl)
- SPI and SSI timing parameters are configurable
- Multiple transport stream packet(188,192,204) format support
- Supports 32-channel PID filter

- Supports hardware PCR packet detecting

TWI

- Up to 5 TWIs(Two Wire Interface)
- Supports Standard mode(up to 100 kbit/s) and Fast mode(up to 400 kbit/s)
- Master/Slave configurable
- Allows 10-bit addressing transactions

Smart Card Reader

- Supports ISO/IEC 7816-3 and EMV2000(4.0) specifications
- Supports synchronous and any other non-ISO 7816 and non-EMV cards
- Supports adjustable clock rate and bit rate
- Configurable automatic byte repetition
- Performs functions needed for complete smart card sessions, including:
 - Card activation and deactivation
 - Cold/warm reset
 - Answer to Reset (ATR) response reception
 - Data transfers to and from the card
- Supports configurable timing functions:
 - Smart Card activation time
 - Smart Card reset time
 - Guard time
 - Timeout timers

SPI

- Up to 4 independent SPI controllers,each SPI controller with two CS signals
- Full-duplex synchronous serial interface
- Master/Slave configurable
- 1-,or 2-wire mode
- Polarity and phase are configurable
- SPI clock is configurable

UART

- Up to 8 UART controllers
 - UART0 with 2 wires for debug tools
 - UART1 with 8 wires
 - UART2/3 each with 4 wires
 - Others with 2 wires
- Compatible with industry-standard 16550 UARTs
- Supports for word length from 5 to 8 bits, an optional parity bit, and 1,1.5 or 2 stop bits
- Programmable parity(even, odd and no parity)

PS2

- Two PS2 controllers
- Compliant with IBM PS2 and AT-compatible keyboard and mouse interface

- Dual-role controller: PS2 host or PS2 device
- Odd parity generation and checking

CIR

- Two CIR controllers
- Flexible receiver for consumer IR remote control
- Programmable FIFO thresholds

SATA

- One SATA Host controller
- Supports SATA 1.5Gb/s and SATA 3.0Gb/s
- Compliant with SATA spec 2.6 and AHCI Revision 1.3 specifications
- Supports external SATA(eSATA)
- Supports power management features including automatic Partial to Slumber transition

Keypad

- One keypad matrix interface up to 8 rows and 8 columns
- Interrupt for key press or key release
- Internal debouncing filter to prevent switching noises

KEYADC

- Up to two ADC channels for key application
- 6-bit resolution
- Voltage input range between 0V to 2V
- Supports hold key, already hold key and continuous key
- Supports single, normal and continuous mode

RTP

- 4-wire I/F
- 12-bit SAR type A/D converter
- Dual touch detection
- Sampling frequency up to 2MHz
- Supports X,Y change function

2.10. Package

- FBGA 468 balls, 0.65mm ball pitch, 16x16 mm

3. Block Diagram

Figure 3-1 shows the block diagram of the A40i processor.

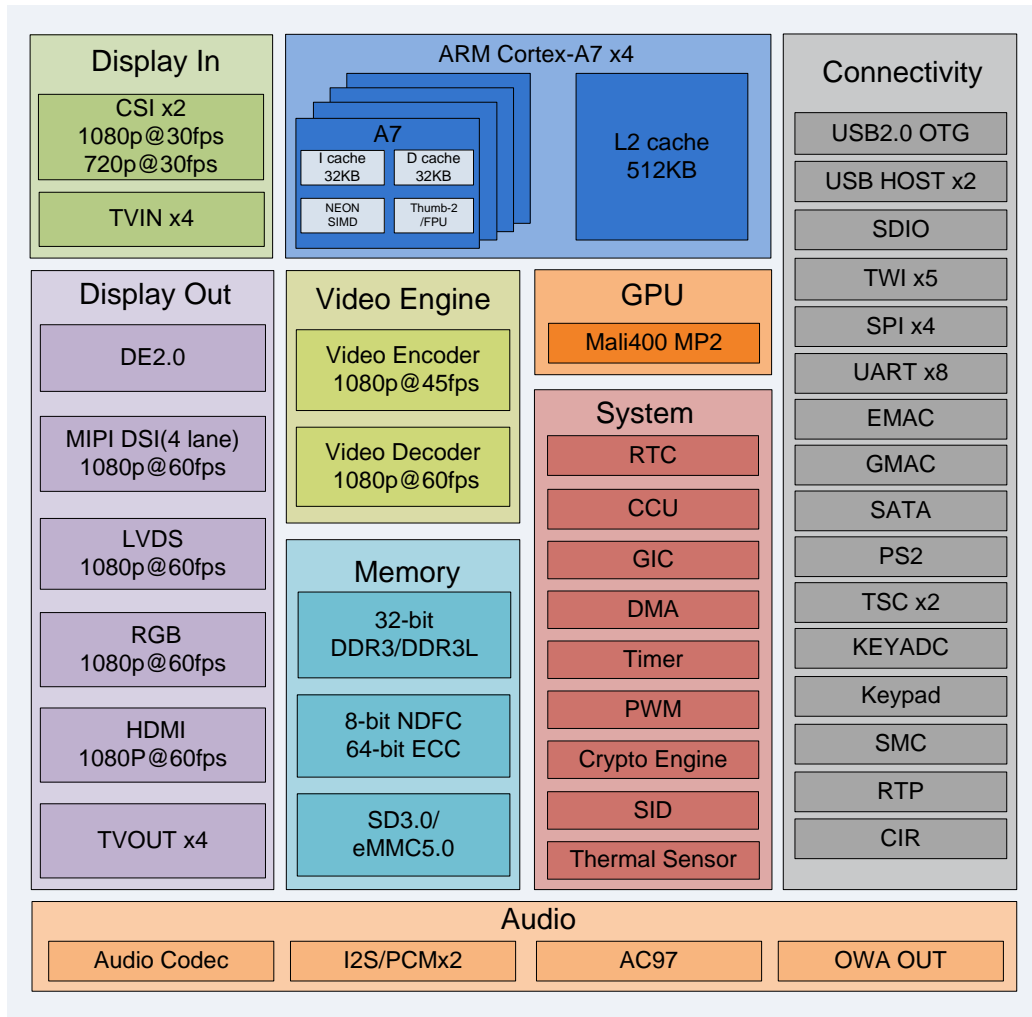

Figure 3-1. A40i Block Diagram

The typical application diagram is shown in Figure 3-2.

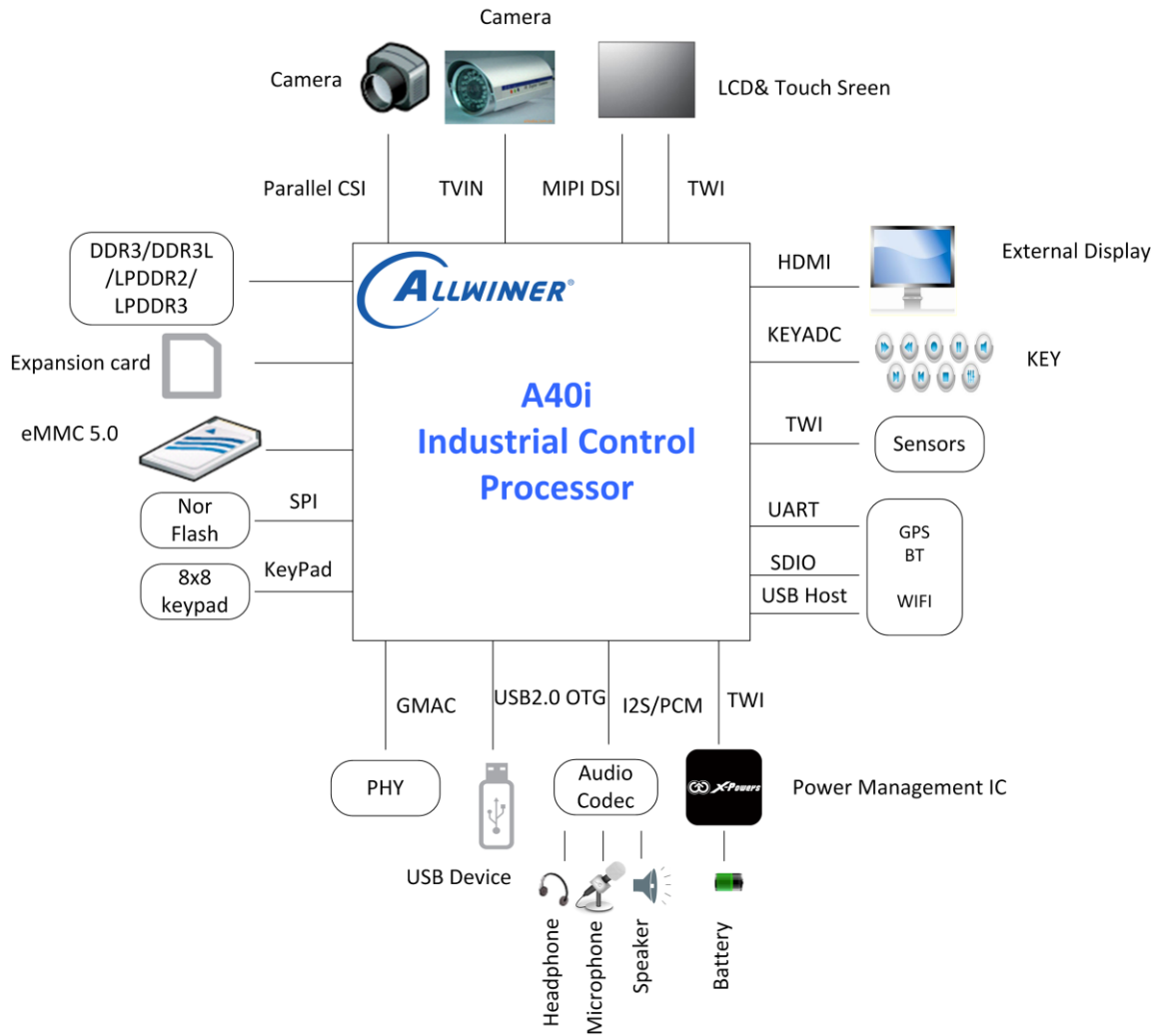

Figure 3-2. A40i Application Diagram

4. Pin Description

4.1. Pin Characteristics

Table 4-1 lists the characteristics of A40i pins from the following ten aspects.

- (1).**Ball#** : Package ball numbers associated with each signals.
- (2).**Pin Name** : The name of the package pin.
- (3).**Signal Name** : The signal name for that pin in the mode being used.
- (4).**Function** : Multiplexing function number.
- (5).**Ball Reset Rel. Function** : The function is automatically configured after RESET from low to high.
- (6).**Type** : Denotes the signal direction
 - I (Input),
 - O (Output),
 - I/O(Input/Output),
 - OD(Open-Drain),
 - A (Analog),
 - AI(Analog Input),
 - AO(Analog Output)
 - P (Power),
 - G (Ground)
- (7).**Ball Reset State** : The state of the terminal at reset.
- (8).**Pull Up/Down** : Denotes the presence of an internal pull-up or pull-down resistor. Pull-up(PU) and pull-down(PD) resistors can be enabled or disabled via software.
- (9).**Buffer Strength** : Defines drive strength of the associated output buffer.
- (10).**Power Supply** : The voltage supply for the terminal's IO buffers.

Table 4-1. Pin Characteristics

Ball# ⁽¹⁾	Pin Name ⁽²⁾	Signal Name ⁽³⁾	Function ⁽⁴⁾	Ball Reset Rel. Function ⁽⁵⁾	Type ⁽⁶⁾	Ball Reset State ⁽⁷⁾	Pull Up/Down ⁽⁸⁾	Buffer Strength ⁽⁹⁾ (mA)	Power Supply ⁽¹⁰⁾
DRAM									
F6	SA0/SCAS	SA0/SCAS	NA	NA	O	Z	NA	NA	VCC-DRAM
H5	SA1	SA1	NA	NA	O	Z	NA	NA	VCC-DRAM
G5	SA2	SA2	NA	NA	O	Z	NA	NA	VCC-DRAM
F4	SA3	SA3	NA	NA	O	Z	NA	NA	VCC-DRAM
E6	SA4/SA11	SA4/SA11	NA	NA	O	Z	NA	NA	VCC-DRAM
E12	SA5	SA5	NA	NA	O	Z	NA	NA	VCC-DRAM
C14	SA6	SA6	NA	NA	O	Z	NA	NA	VCC-DRAM
F13	SA7/SBA0	SA7/SBA0	NA	NA	O	Z	NA	NA	VCC-DRAM
D16	SA8	SA8	NA	NA	O	Z	NA	NA	VCC-DRAM
E17	SA9	SA9	NA	NA	O	Z	NA	NA	VCC-DRAM
E11	SA10	SA10	NA	NA	O	Z	NA	NA	VCC-DRAM
E7	SA11/SA4	SA11/SA4	NA	NA	O	Z	NA	NA	VCC-DRAM
C13	SA12	SA12	NA	NA	O	Z	NA	NA	VCC-DRAM
H3	SA13	SA13	NA	NA	O	Z	NA	NA	VCC-DRAM
E9	SA14	SA14	NA	NA	O	Z	NA	NA	VCC-DRAM
E4	SA15/SCS1	SA15/SCS1	NA	NA	O	Z	NA	NA	VCC-DRAM
C16	SBA0/SA7	SBA0/SA7	NA	NA	O	Z	NA	NA	VCC-DRAM
E14	SBA1	SBA1	NA	NA	O	Z	NA	NA	VCC-DRAM
D17	SBA2	SBA2	NA	NA	O	Z	NA	NA	VCC-DRAM
C5	SCAS/SA0	SCAS/SA0	NA	NA	O	Z	NA	NA	VCC-DRAM
C8	SCKN	SCKN	NA	NA	O	Z	NA	NA	VCC-DRAM
C7	SCKP	SCKP	NA	NA	O	Z	NA	NA	VCC-DRAM
C6	SCKE0	SCKE0	NA	NA	O	Z	NA	NA	VCC-DRAM
D3	SCKE1	SCKE1	NA	NA	O	Z	NA	NA	VCC-DRAM
F3	SCS0	SCS0	NA	NA	O	Z	NA	NA	VCC-DRAM
D6	SODT0	SODT0	NA	NA	O	Z	NA	NA	VCC-DRAM
C3	SODT1	SODT1	NA	NA	O	Z	NA	NA	VCC-DRAM
F2	SDQ0	SDQ0	NA	NA	I/O	Z	NA	NA	VCC-DRAM
D2	SDQ1	SDQ1	NA	NA	I/O	Z	NA	NA	VCC-DRAM
G1	SDQ2	SDQ2	NA	NA	I/O	Z	NA	NA	VCC-DRAM
D1	SDQ3	SDQ3	NA	NA	I/O	Z	NA	NA	VCC-DRAM
G2	SDQ4	SDQ4	NA	NA	I/O	Z	NA	NA	VCC-DRAM
F1	SDQ5	SDQ5	NA	NA	I/O	Z	NA	NA	VCC-DRAM
C1	SDQ6	SDQ6	NA	NA	I/O	Z	NA	NA	VCC-DRAM
C2	SDQ7	SDQ7	NA	NA	I/O	Z	NA	NA	VCC-DRAM
A5	SDQ8	SDQ8	NA	NA	I/O	Z	NA	NA	VCC-DRAM
A3	SDQ9	SDQ9	NA	NA	I/O	Z	NA	NA	VCC-DRAM
A6	SDQ10	SDQ10	NA	NA	I/O	Z	NA	NA	VCC-DRAM
A2	SDQ11	SDQ11	NA	NA	I/O	Z	NA	NA	VCC-DRAM
B3	SDQ12	SDQ12	NA	NA	I/O	Z	NA	NA	VCC-DRAM
B6	SDQ13	SDQ13	NA	NA	I/O	Z	NA	NA	VCC-DRAM
B2	SDQ14	SDQ14	NA	NA	I/O	Z	NA	NA	VCC-DRAM
B5	SDQ15	SDQ15	NA	NA	I/O	Z	NA	NA	VCC-DRAM
B7	SDQ16	SDQ16	NA	NA	I/O	Z	NA	NA	VCC-DRAM
C11	SDQ17	SDQ17	NA	NA	I/O	Z	NA	NA	VCC-DRAM
A8	SDQ18	SDQ18	NA	NA	I/O	Z	NA	NA	VCC-DRAM
C9	SDQ19	SDQ19	NA	NA	I/O	Z	NA	NA	VCC-DRAM
B11	SDQ20	SDQ20	NA	NA	I/O	Z	NA	NA	VCC-DRAM
B9	SDQ21	SDQ21	NA	NA	I/O	Z	NA	NA	VCC-DRAM
C12	SDQ22	SDQ22	NA	NA	I/O	Z	NA	NA	VCC-DRAM
A9	SDQ23	SDQ23	NA	NA	I/O	Z	NA	NA	VCC-DRAM
A16	SDQ24	SDQ24	NA	NA	I/O	Z	NA	NA	VCC-DRAM
A13	SDQ25	SDQ25	NA	NA	I/O	Z	NA	NA	VCC-DRAM
A17	SDQ26	SDQ26	NA	NA	I/O	Z	NA	NA	VCC-DRAM
A14	SDQ27	SDQ27	NA	NA	I/O	Z	NA	NA	VCC-DRAM
B13	SDQ28	SDQ28	NA	NA	I/O	Z	NA	NA	VCC-DRAM
B17	SDQ29	SDQ29	NA	NA	I/O	Z	NA	NA	VCC-DRAM
B14	SDQ30	SDQ30	NA	NA	I/O	Z	NA	NA	VCC-DRAM
B16	SDQ31	SDQ31	NA	NA	I/O	Z	NA	NA	VCC-DRAM
G3	SDQM0	SDQM0	NA	NA	O	Z	NA	NA	VCC-DRAM

Ball# ⁽¹⁾	Pin Name ⁽²⁾	Signal Name ⁽³⁾	Function ⁽⁴⁾	Ball Reset Rel. Function ⁽⁵⁾	Type ⁽⁶⁾	Ball Reset State ⁽⁷⁾	Pull Up/Down ⁽⁸⁾	Buffer Strength ⁽⁹⁾ (mA)	Power Supply ⁽¹⁰⁾
B1	SDQM1	SDQM1	NA	NA	O	Z	NA	NA	VCC-DRAM
A7	SDQM2	SDQM2	NA	NA	O	Z	NA	NA	VCC-DRAM
A12	SDQM3	SDQM3	NA	NA	O	Z	NA	NA	VCC-DRAM
E2	SDQS0N	SDQS0N	NA	NA	I/O	Z	NA	NA	VCC-DRAM
E1	SDQS0P	SDQS0P	NA	NA	I/O	Z	NA	NA	VCC-DRAM
B4	SDQS1N	SDQS1N	NA	NA	I/O	Z	NA	NA	VCC-DRAM
A4	SDQS1P	SDQS1P	NA	NA	I/O	Z	NA	NA	VCC-DRAM
B10	SDQS2N	SDQS2N	NA	NA	I/O	Z	NA	NA	VCC-DRAM
A10	SDQS2P	SDQS2P	NA	NA	I/O	Z	NA	NA	VCC-DRAM
B15	SDQS3N	SDQS3N	NA	NA	I/O	Z	NA	NA	VCC-DRAM
A15	SDQS3P	SDQS3P	NA	NA	I/O	Z	NA	NA	VCC-DRAM
E15	SRAS	SRAS	NA	NA	O	Z	NA	NA	VCC-DRAM
E8	SRST	SRST	NA	NA	O	Z	NA	NA	VCC-DRAM
D9	SVREF	SVREF	NA	NA	P	Z	NA	NA	VCC-DRAM
G6	SWE	SWE	NA	NA	O	Z	NA	NA	VCC-DRAM
H1	SZQ	SZQ	NA	NA	AI	Z	NA	NA	VCC-DRAM
G11,G12,G14, G15,G16,H7,H10, H12,H13,J8	VCC-DRAM	VCC-DRAM	NA	NA	P	NA	NA	NA	NA

GPIOA

L23	PA0	Input	0	Function7	I	Z	PU/PD	6	VCC-PA
		Output	1		O				
		ERXD3	2		I				
		SPI1_CS0	3		I/O				
		UART2_RTS	4		O				
		GRXD3	5		I				
		Reserved	6		NA				
		IO Disable	7		OFF				
M19	PA1	Input	0	Function7	I	Z	PU/PD	6	VCC-PA
		Output	1		O				
		ERXD2	2		I				
		SPI1_CLK	3		I/O				
		UART2_CTS	4		I				
		GRXD2	5		I				
		Reserved	6		NA				
		IO Disable	7		OFF				
M23	PA2	Input	0	Function7	I	Z	PU/PD	6	VCC-PA
		Output	1		O				
		ERXD1	2		I				
		SPI1_MOSI	3		I/O				
		UART2_TX	4		O				
		GRXD1	5		I				
		Reserved	6		NA				
		IO Disable	7		OFF				
M22	PA3	Input	0	Function7	I	Z	PU/PD	6	VCC-PA
		Output	1		O				
		ERXD0	2		I				
		SPI1_MISO	3		I/O				
		UART2_RX	4		I				
		GRXD0	5		I				
		Reserved	6		NA				
		IO Disable	7		OFF				
M21	PA4	Input	0	Function7	I	Z	PU/PD	6	VCC-PA
		Output	1		O				
		ETXD3	2		O				
		SPI1_CS1	3		I/O				
		Reserved	4		NA				
		GTXD3	5		O				
		Reserved	6		NA				
		IO Disable	7		OFF				
M20	PA5	Input	0	Function7	I	Z	PU/PD	6	VCC-PA
		Output	1		O				
		ETXD2	2		O				
		SPI3_CS0	3		I/O				
		Reserved	4		NA				

Ball# ⁽¹⁾	Pin Name ⁽²⁾	Signal Name ⁽³⁾	Function ⁽⁴⁾	Ball Reset Rel. Function ⁽⁵⁾	Type ⁽⁶⁾	Ball Reset State ⁽⁷⁾	Pull Up/Down ⁽⁸⁾	Buffer Strength ⁽⁹⁾ (mA)	Power Supply ⁽¹⁰⁾
		GTXD2	5		O				
		Reserved	6		NA				
		IO Disable	7		OFF				
M24	PA6	Input	0	Function7	I	Z	PU/PD	6	VCC-PA
		Output	1		O				
		ETXD1	2		O				
		SPI3_CLK	3		I/O				
		Reserved	4		NA				
		GTXD1	5		O				
		Reserved	6		NA				
		IO Disable	7		OFF				
N24	PA7	Input	0	Function7	I	Z	PU/PD	6	VCC-PA
		Output	1		O				
		ETXD0	2		O				
		SPI3_MOSI	3		I/O				
		Reserved	4		NA				
		GTXD0	5		O				
		Reserved	6		NA				
		IO Disable	7		OFF				
N23	PA8	Input	0	Function7	I	Z	PU/PD	6	VCC-PA
		Output	1		O				
		ERXCK	2		I				
		SPI3_MISO	3		I/O				
		Reserved	4		NA				
		GRXCK	5		I				
		Reserved	6		NA				
		IO Disable	7		OFF				
N22	PA9	Input	0	Function7	I	Z	PU/PD	6	VCC-PA
		Output	1		O				
		ERXERR	2		I				
		SPI3_CS1	3		I/O				
		Reserved	4		NA				
		GNUL/ERXERR	5		I				
		I2S1_MCLK	6		O				
		IO Disable	7		OFF				
N21	PA10	Input	0	Function7	I	Z	PU/PD	6	VCC-PA
		Output	1		O				
		ERXDV	2		I				
		Reserved	3		NA				
		UART1_TX	4		O				
		GRXCTL/ERXDV	5		I				
		Reserved	6		NA				
		IO Disable	7		OFF				
N20	PA11	Input	0	Function7	I	Z	PU/PD	6	VCC-PA
		Output	1		O				
		EMDC	2		O				
		Reserved	3		NA				
		UART1_RX	4		I				
		GMDC	5		O				
		Reserved	6		NA				
		IO Disable	7		OFF				
N19	PA12	Input	0	Function7	I	Z	PU/PD	6	VCC-PA
		Output	1		O				
		EMDIO	2		I/O				
		UART6_TX	3		O				
		UART1_RTS	4		O				
		GMDIO	5		I/O				
		Reserved	6		NA				
		IO Disable	7		OFF				
P23	PA13	Input	0	Function7	I	Z	PU/PD	6	VCC-PA
		Output	1		O				
		ETXEN	2		O				
		UART6_RX	3		I				
		UART1_CTS	4		I				

Ball# ⁽¹⁾	Pin Name ⁽²⁾	Signal Name ⁽³⁾	Function ⁽⁴⁾	Ball Reset Rel. Function ⁽⁵⁾	Type ⁽⁶⁾	Ball Reset State ⁽⁷⁾	Pull Up/Down ⁽⁸⁾	Buffer Strength ⁽⁹⁾ (mA)	Power Supply ⁽¹⁰⁾
		GTXCTL/ETXEN	5		O				
		Reserved	6		NA				
		IO Disable	7		OFF				
P22	PA14	Input	0	Function7	I	Z	PU/PD	6	VCC-PA
		Output	1		O				
		ETXCK	2		I				
		UART7_TX	3		O				
		UART1_DTR	4		O				
		GNULL/ETXCK	5		I				
		I2S1_BCLK	6		I/O				
		IO Disable	7		OFF				
R22	PA15	Input	0	Function7	I	Z	PU/PD	6	VCC-PA
		Output	1		O				
		ECRS	2		I				
		UART7_RX	3		I				
		UART1_DSR	4		I				
		GTXCK/ECRS	5		O,I				
		I2S1_LRCK	6		I/O				
		IO Disable	7		OFF				
R21	PA16	Input	0	Function7	I	Z	PU/PD	6	VCC-PA
		Output	1		O				
		ECOL	2		I				
		Reserved	3		O				
		UART1_DCD	4		I				
		GCLKIN/ECOL	5		I				
		I2S1_DO	6		O				
		IO Disable	7		OFF				
R20	PA17	Input	0	Function7	I	Z	PU/PD	6	VCC-PA
		Output	1		O				
		ETXERR	2		O				
		Reserved	3		I				
		UART1_RING	4		I				
		GNULL/ETXERR	5		O				
		I2S1_DI	6		I				
		IO Disable	7		OFF				
L17	VCC-PA	VCC-PA	NA	NA	P	NA	NA	NA	NA
GPIOB									
L22	PB0	Input	0	Function7	I	Z	PU/PD	6	VCC-IO
		Output	1		O				
		TWI0_SCK	2		I/O				
		PLL_LOCK_DBG	3		I/O				
		Reserved	4		NA				
		Reserved	5		NA				
		Reserved	6		NA				
		IO Disable	7		OFF				
K22	PB1	Input	0	Function7	I	Z	PU/PD	6	VCC-IO
		Output	1		O				
		TWI0_SDA	2		I/O				
		Reserved	3		NA				
		Reserved	4		NA				
		Reserved	5		NA				
		Reserved	6		NA				
		IO Disable	7		OFF				
K23	PB2	Input	0	Function7	I	Z	PU/PD	6	VCC-IO
		Output	1		O				
		Reserved	2		NA				
		PWM0	3		I/O				
		Reserved	4		NA				
		Reserved	5		NA				
		Reserved	6		NA				
		IO Disable	7		OFF				
K24	PB3	Input	0	Function7	I	Z	PU/PD	6	VCC-IO
		Output	1		O				
		Reserved	2		NA				

Ball# ⁽¹⁾	Pin Name ⁽²⁾	Signal Name ⁽³⁾	Function ⁽⁴⁾	Ball Reset Rel. Function ⁽⁵⁾	Type ⁽⁶⁾	Ball Reset State ⁽⁷⁾	Pull Up/Down ⁽⁸⁾	Buffer Strength ⁽⁹⁾ (mA)	Power Supply ⁽¹⁰⁾
		PWM1	3		I/O				
		OWA_MCLK	4		O				
		Reserved	5		NA				
		Reserved	6		NA				
		IO Disable	7		OFF				
J24	PB4	Input	0	Function7	I	Z	PU/PD	6	VCC-IO
		Output	1		O				
		CIRO_RX	2		I				
		Reserved	3		NA				
		Reserved	4		NA				
		Reserved	5		NA				
		Reserved	6		NA				
		IO Disable	7		OFF				
K20	PB5	Input	0	Function7	I	Z	PU/PD	6	VCC-IO
		Output	1		O				
		I2S_MCLK	2		O				
		AC97_MCLK	3		O				
		Reserved	4		NA				
		Reserved	5		NA				
		Reserved	6		NA				
		IO Disable	7		OFF				
K21	PB6	Input	0	Function7	I	Z	PU/PD	6	VCC-IO
		Output	1		O				
		I2S_BCLK	2		I/O				
		AC97_BCLK	3		I				
		Reserved	4		NA				
		Reserved	5		NA				
		Reserved	6		NA				
		IO Disable	7		OFF				
J20	PB7	Input	0	Function7	I	Z	PU/PD	6	VCC-IO
		Output	1		O				
		I2S_LRCK	2		I/O				
		AC97_SYNC	3		O				
		Reserved	4		NA				
		Reserved	5		NA				
		Reserved	6		NA				
		IO Disable	7		OFF				
J21	PB8	Input	0	Function7	I	Z	PU/PD	6	VCC-IO
		Output	1		O				
		I2S_DO0	2		O				
		AC97_DO	3		O				
		Reserved	4		NA				
		Reserved	5		NA				
		Reserved	6		NA				
		IO Disable	7		OFF				
J22	PB9	Input	0	Function7	I	Z	PU/PD	6	VCC-IO
		Output	1		O				
		I2S_DO1	2		O				
		Reserved	3		NA				
		PWM6	4		I/O				
		Reserved	5		NA				
		Reserved	6		NA				
		IO Disable	7		OFF				
J23	PB10	Input	0	Function7	I	Z	PU/PD	6	VCC-IO
		Output	1		O				
		I2S_DO2	2		O				
		Reserved	3		NA				
		PWM7	4		I/O				
		Reserved	5		NA				
		Reserved	6		NA				
		IO Disable	7		OFF				
J19	PB11	Input	0	Function7	I	Z	PU/PD	6	VCC-IO
		Output	1		O				
		I2S_DO3	2		O				

Ball# ⁽¹⁾	Pin Name ⁽²⁾	Signal Name ⁽³⁾	Function ⁽⁴⁾	Ball Reset Rel. Function ⁽⁵⁾	Type ⁽⁶⁾	Ball Reset State ⁽⁷⁾	Pull Up/Down ⁽⁸⁾	Buffer Strength ⁽⁹⁾ (mA)	Power Supply ⁽¹⁰⁾
		Reserved	3		NA				
		Reserved	4		NA				
		Reserved	5		NA				
		Reserved	6		NA				
		IO Disable	7		OFF				
G19	PB12	Input	0	Function7	I	Z	PU/PD	6	VCC-IO
		Output	1		O				
		I2S_DI	2		I				
		AC97_DI	3		I				
		Reserved	4		NA				
		Reserved	5		NA				
		Reserved	6		NA				
		IO Disable	7		OFF				
G20	PB13	Input	0	Function7	I	Z	PU/PD	6	VCC-IO
		Output	1		O				
		SPI2_CS1	2		I/O				
		Reserved	3		NA				
		OWA_DO	4		O				
		Reserved	5		NA				
		Reserved	6		NA				
		IO Disable	7		OFF				
G21	PB14	Input	0	Function7	I	Z	PU/PD	6	VCC-IO
		Output	1		O				
		SPI2_CS0	2		I/O				
		JTAG_MS0	3		I				
		Reserved	4		NA				
		Reserved	5		NA				
		Reserved	6		NA				
		IO Disable	7		OFF				
H22	PB15	Input	0	Function7	I	Z	PU/PD	6	VCC-IO
		Output	1		O				
		SPI2_CLK	2		I/O				
		JTAG_CK0	3		I				
		Reserved	4		NA				
		Reserved	5		NA				
		Reserved	6		NA				
		IO Disable	7		OFF				
H23	PB16	Input	0	Function7	I	Z	PU/PD	6	VCC-IO
		Output	1		O				
		SPI2_MOSI	2		I/O				
		JTAG_DO0	3		O				
		Reserved	4		NA				
		Reserved	5		NA				
		Reserved	6		NA				
		IO Disable	7		OFF				
G22	PB17	Input	0	Function7	I	Z	PU/PD	6	VCC-IO
		Output	1		O				
		SPI2_MISO	2		I/O				
		JTAG_DIO	3		I				
		Reserved	4		NA				
		Reserved	5		NA				
		Reserved	6		NA				
		IO Disable	7		OFF				
G23	PB18	Input	0	Function7	I	Z	PU/PD	6	VCC-IO
		Output	1		O				
		TWI1_SCK	2		I/O				
		Reserved	3		NA				
		Reserved	4		NA				
		Reserved	5		NA				
		Reserved	6		NA				
		IO Disable	7		OFF				
G24	PB19	Input	0	Function7	I	Z	PU/PD	6	VCC-IO
		Output	1		O				
		TWI1_SDA	2		I/O				

Ball# ⁽¹⁾	Pin Name ⁽²⁾	Signal Name ⁽³⁾	Function ⁽⁴⁾	Ball Reset Rel. Function ⁽⁵⁾	Type ⁽⁶⁾	Ball Reset State ⁽⁷⁾	Pull Up/Down ⁽⁸⁾	Buffer Strength ⁽⁹⁾ (mA)	Power Supply ⁽¹⁰⁾
		Reserved	3		NA				
		Reserved	4		NA				
		Reserved	5		NA				
		Reserved	6		NA				
		IO Disable	7		OFF				
F24	PB20	Input	0	Function7	I	Z	PU/PD	6	VCC-IO
		Output	1		O				
		TWI2_SCK	2		I/O				
		Reserved	3		NA				
		PWM4	4		I/O				
		Reserved	5		NA				
		Reserved	6		NA				
		IO Disable	7		OFF				
F21	PB21	Input	0	Function7	I	Z	PU/PD	6	VCC-IO
		Output	1		O				
		TWI2_SDA	2		I/O				
		Reserved	3		NA				
		PWM5	4		I/O				
		Reserved	5		NA				
		Reserved	6		NA				
		IO Disable	7		OFF				
F22	PB22	Input	0	Function7	I	Z	PU/PD	6	VCC-IO
		Output	1		O				
		UART0_TX	2		O				
		Reserved	3		NA				
		Reserved	4		NA				
		Reserved	5		NA				
		Reserved	6		NA				
		IO Disable	7		OFF				
F23	PB23	Input	0	Function7	I	Z	PU/PD	6	VCC-IO
		Output	1		O				
		UART0_RX	2		I				
		CIR1_RX	3		I				
		Reserved	4		NA				
		Reserved	5		NA				
		Reserved	6		NA				
		IO Disable	7		OFF				
GPIOC									
AB11	PC0	Input	0	Function7	I	Z	PU/PD	6	VCC-PC
		Output	1		O				
		NWE	2		O				
		SPI0_MOSI	3		I/O				
		Reserved	4		NA				
		Reserved	5		NA				
		Reserved	6		NA				
		IO Disable	7		OFF				
AC10	PC1	Input	0	Function7	I	Z	PU/PD	6	VCC-PC
		Output	1		O				
		NALE	2		O				
		SPI0_MISO	3		I/O				
		Reserved	4		NA				
		Reserved	5		NA				
		Reserved	6		NA				
		IO Disable	7		OFF				
AD10	PC2	Input	0	Function7	I	Z	PU/PD	6	VCC-PC
		Output	1		O				
		NCLE	2		O				
		SPI0_CLK	3		I/O				
		Reserved	4		NA				
		Reserved	5		NA				
		Reserved	6		NA				
		IO Disable	7		OFF				
AB12	PC3	Input	0	Function7	I	PU	PU/PD	6	VCC-PC
		Output	1		O				

Ball# ⁽¹⁾	Pin Name ⁽²⁾	Signal Name ⁽³⁾	Function ⁽⁴⁾	Ball Reset Rel. Function ⁽⁵⁾	Type ⁽⁶⁾	Ball Reset State ⁽⁷⁾	Pull Up/Down ⁽⁸⁾	Buffer Strength ⁽⁹⁾ (mA)	Power Supply ⁽¹⁰⁾
		NCE1	2		O				
		Reserved	3		NA				
		Reserved	4		NA				
		Reserved	5		NA				
		Reserved	6		NA				
		IO Disable	7		OFF				
W16	PC4	Input	0	Function7	I	PU	PU/PD	6	VCC-PC
		Output	1		O				
		NCE0	2		O				
		Reserved	3		NA				
		Reserved	4		NA				
		Reserved	5		NA				
		Reserved	6		NA				
		IO Disable	7		OFF				
AC18	PC5	Input	0	Function7	I	Z	PU/PD	6	VCC-PC
		Output	1		O				
		NRE	2		O				
		SDC2_DS	3		I				
		Reserved	4		NA				
		Reserved	5		NA				
		Reserved	6		NA				
		IO Disable	7		OFF				
AC12	PC6	Input	0	Function7	I	PU	PU/PD	6	VCC-PC
		Output	1		O				
		NRB0	2		I				
		SDC2_CMD	3		I/O				
		Reserved	4		NA				
		Reserved	5		NA				
		Reserved	6		NA				
		IO Disable	7		OFF				
AB13	PC7	Input	0	Function7	I	PU	PU/PD	6	VCC-PC
		Output	1		O				
		NRB1	2		I				
		SDC2_CLK	3		O				
		Reserved	4		NA				
		Reserved	5		NA				
		Reserved	6		NA				
		IO Disable	7		OFF				
AC14	PC8	Input	0	Function7	I	Z	PU/PD	6	VCC-PC
		Output	1		O				
		NDQ0	2		I/O				
		SDC2_D0	3		I/O				
		Reserved	4		NA				
		Reserved	5		NA				
		Reserved	6		NA				
		IO Disable	7		OFF				
AB15	PC9	Input	0	Function7	I	Z	PU/PD	6	VCC-PC
		Output	1		O				
		NDQ1	2		I/O				
		SDC2_D1	3		I/O				
		Reserved	4		NA				
		Reserved	5		NA				
		Reserved	6		NA				
		IO Disable	7		OFF				
AC17	PC10	Input	0	Function7	I	Z	PU/PD	6	VCC-PC
		Output	1		O				
		NDQ2	2		I/O				
		SDC2_D2	3		I/O				
		Reserved	4		NA				
		Reserved	5		NA				
		Reserved	6		NA				
		IO Disable	7		OFF				
AC13	PC11	Input	0	Function7	I	Z	PU/PD	6	VCC-PC
		Output	1		O				

Ball# ⁽¹⁾	Pin Name ⁽²⁾	Signal Name ⁽³⁾	Function ⁽⁴⁾	Ball Reset Rel. Function ⁽⁵⁾	Type ⁽⁶⁾	Ball Reset State ⁽⁷⁾	Pull Up/Down ⁽⁸⁾	Buffer Strength ⁽⁹⁾ (mA)	Power Supply ⁽¹⁰⁾
		NDQ3	2		I/O				
		SDC2_D3	3		I/O				
		Reserved	4		NA				
		Reserved	5		NA				
		Reserved	6		NA				
		IO Disable	7		OFF				
AD14	PC12	Input	0	Function7	I	Z	PU/PD	6	VCC-PC
		Output	1		O				
		NDQ4	2		I/O				
		SDC2_D4	3		I/O				
		Reserved	4		NA				
		Reserved	5		NA				
		Reserved	6		NA				
		IO Disable	7		OFF				
AC15	PC13	Input	0	Function7	I	Z	PU/PD	6	VCC-PC
		Output	1		O				
		NDQ5	2		I/O				
		SDC2_D5	3		I/O				
		Reserved	4		NA				
		Reserved	5		NA				
		Reserved	6		NA				
		IO Disable	7		OFF				
AD16	PC14	Input	0	Function7	I	Z	PU/PD	6	VCC-PC
		Output	1		O				
		NDQ6	2		I/O				
		SDC2_D6	3		I/O				
		Reserved	4		NA				
		Reserved	5		NA				
		Reserved	6		NA				
		IO Disable	7		OFF				
AD17	PC15	Input	0	Function7	I	Z	PU/PD	6	VCC-PC
		Output	1		O				
		NDQ7	2		I/O				
		SDC2_D7	3		I/O				
		Reserved	4		NA				
		Reserved	5		NA				
		Reserved	6		NA				
		IO Disable	7		OFF				
Y14	PC16	Input	0	Function7	I	PD	PU/PD	6	VCC-PC
		Output	1		O				
		NWP	2		O				
		Reserved	3		NA				
		Reserved	4		NA				
		Reserved	5		NA				
		Reserved	6		NA				
		IO Disable	7		OFF				
AC16	PC17	Input	0	Function7	I	PU	PU/PD	6	VCC-PC
		Output	1		O				
		NCE2	2		O				
		Reserved	3		NA				
		Reserved	4		NA				
		Reserved	5		NA				
		Reserved	6		NA				
		IO Disable	7		OFF				
AB16	PC18	Input	0	Function7	I	PU	PU/PD	6	VCC-PC
		Output	1		O				
		NCE3	2		O				
		Reserved	3		NA				
		Reserved	4		NA				
		Reserved	5		NA				
		Reserved	6		NA				
		IO Disable	7		OFF				
AA16	PC19	Input	0	Function7	I	Z	PU/PD	6	VCC-PC
		Output	1		O				

Ball# ⁽¹⁾	Pin Name ⁽²⁾	Signal Name ⁽³⁾	Function ⁽⁴⁾	Ball Reset Rel. Function ⁽⁵⁾	Type ⁽⁶⁾	Ball Reset State ⁽⁷⁾	Pull Up/Down ⁽⁸⁾	Buffer Strength ⁽⁹⁾ (mA)	Power Supply ⁽¹⁰⁾
		NCE4	2		O				
		SPI2_CS0	3		I/O				
		Reserved	4		NA				
		Reserved	5		NA				
		Reserved	6		NA				
		IO Disable	7		OFF				
AB18	PC20	Input	0	Function7	I	Z	PU/PD	6	VCC-PC
		Output	1		O				
		NCE5	2		O				
		SPI2_CLK	3		I/O				
		Reserved	4		NA				
		Reserved	5		NA				
		Reserved	6		NA				
		IO Disable	7		OFF				
AA14	PC21	Input	0	Function7	I	Z	PU/PD	6	VCC-PC
		Output	1		O				
		NCE6	2		O				
		SPI2_MOSI	3		I/O				
		Reserved	4		NA				
		Reserved	5		NA				
		Reserved	6		NA				
		IO Disable	7		OFF				
Y16	PC22	Input	0	Function7	I	Z	PU/PD	6	VCC-PC
		Output	1		O				
		NCE7	2		O				
		SPI2_MISO	3		I/O				
		Reserved	4		NA				
		Reserved	5		NA				
		Reserved	6		NA				
		IO Disable	7		OFF				
AB17	PC23	Input	0	Function7	I	PU	PU/PD	6	VCC-PC
		Output	1		O				
		Reserved	2		NA				
		SPIO_CS0	3		I/O				
		Reserved	4		NA				
		Reserved	5		NA				
		Reserved	6		NA				
		IO Disable	7		OFF				
AD13	PC24	Input	0	Function7	I	Z	PU/PD	6	VCC-PC
		Output	1		O				
		NDQS	2		I/O				
		SDC2_RST	3		O				
		Reserved	4		NA				
		Reserved	5		NA				
		Reserved	6		NA				
		IO Disable	7		OFF				
T15,U15	VCC-PC	VCC-PC	NA	NA	P	NA	NA	NA	NA
GPIOD									
M2	PD0	Input	0	Function7	I	Z	PU/PD	6	VCC-PD
		Output	1		O				
		LCD0_D0	2		O				
		LVDS0_VP0	3		O				
		Reserved	4		NA				
		Reserved	5		NA				
		Reserved	6		NA				
		IO Disable	7		OFF				
M1	PD1	Input	0	Function7	I	Z	PU/PD	6	VCC-PD
		Output	1		O				
		LCD0_D1	2		O				
		LVDS0_VN0	3		O				
		Reserved	4		NA				
		Reserved	5		NA				
		Reserved	6		NA				
		IO Disable	7		OFF				

Ball# ⁽¹⁾	Pin Name ⁽²⁾	Signal Name ⁽³⁾	Function ⁽⁴⁾	Ball Reset Rel. Function ⁽⁵⁾	Type ⁽⁶⁾	Ball Reset State ⁽⁷⁾	Pull Up/Down ⁽⁸⁾	Buffer Strength ⁽⁹⁾ (mA)	Power Supply ⁽¹⁰⁾
N2	PD2	Input	0	Function7	I	Z	PU/PD	6	VCC-PD
		Output	1		O				
		LCD0_D2	2		O				
		LVDS0_VP1	3		O				
		Reserved	4		NA				
		Reserved	5		NA				
		Reserved	6		NA				
		IO Disable	7		OFF				
M3	PD3	Input	0	Function7	I	Z	PU/PD	6	VCC-PD
		Output	1		O				
		LCD0_D3	2		O				
		LVDS0_VN1	3		O				
		Reserved	4		NA				
		Reserved	5		NA				
		Reserved	6		NA				
		IO Disable	7		OFF				
P1	PD4	Input	0	Function7	I	Z	PU/PD	6	VCC-PD
		Output	1		O				
		LCD0_D4	2		O				
		LVDS0_VP2	3		O				
		Reserved	4		NA				
		Reserved	5		NA				
		Reserved	6		NA				
		IO Disable	7		OFF				
P2	PD5	Input	0	Function7	I	Z	PU/PD	6	VCC-PD
		Output	1		O				
		LCD0_D5	2		O				
		LVDS0_VN2	3		O				
		Reserved	4		NA				
		Reserved	5		NA				
		Reserved	6		NA				
		IO Disable	7		OFF				
R1	PD6	Input	0	Function7	I	Z	PU/PD	6	VCC-PD
		Output	1		O				
		LCD0_D6	2		O				
		LVDS0_VPC	3		O				
		Reserved	4		NA				
		Reserved	5		NA				
		Reserved	6		NA				
		IO Disable	7		OFF				
P3	PD7	Input	0	Function7	I	Z	PU/PD	6	VCC-PD
		Output	1		O				
		LCD0_D7	2		O				
		LVDS0_VNC	3		O				
		Reserved	4		NA				
		Reserved	5		NA				
		Reserved	6		NA				
		IO Disable	7		OFF				
R2	PD8	Input	0	Function7	I	Z	PU/PD	6	VCC-PD
		Output	1		O				
		LCD0_D8	2		O				
		LVDS0_VP3	3		O				
		Reserved	4		NA				
		Reserved	5		NA				
		Reserved	6		NA				
		IO Disable	7		OFF				
R3	PD9	Input	0	Function7	I	Z	PU/PD	6	VCC-PD
		Output	1		O				
		LCD0_D9	2		O				
		LVDS0_VN3	3		O				
		Reserved	4		NA				
		Reserved	5		NA				
		Reserved	6		NA				
		IO Disable	7		OFF				

Ball# ⁽¹⁾	Pin Name ⁽²⁾	Signal Name ⁽³⁾	Function ⁽⁴⁾	Ball Reset Rel. Function ⁽⁵⁾	Type ⁽⁶⁾	Ball Reset State ⁽⁷⁾	Pull Up/Down ⁽⁸⁾	Buffer Strength ⁽⁹⁾ (mA)	Power Supply ⁽¹⁰⁾
L5	PD10	Input	0	Function7	I	Z	PU/PD	6	VCC-PD
		Output	1		O				
		LCD0_D10	2		O				
		LVDS1_VP0	3		O				
		Reserved	4		NA				
		Reserved	5		NA				
		Reserved	6		NA				
		IO Disable	7		OFF				
L4	PD11	Input	0	Function7	I	Z	PU/PD	6	VCC-PD
		Output	1		O				
		LCD0_D11	2		O				
		LVDS1_VN0	3		O				
		Reserved	4		NA				
		Reserved	5		NA				
		Reserved	6		NA				
		IO Disable	7		OFF				
L3	PD12	Input	0	Function7	I	Z	PU/PD	6	VCC-PD
		Output	1		O				
		LCD0_D12	2		O				
		LVDS1_VP1	3		O				
		Reserved	4		NA				
		Reserved	5		NA				
		Reserved	6		NA				
		IO Disable	7		OFF				
M4	PD13	Input	0	Function7	I	Z	PU/PD	6	VCC-PD
		Output	1		O				
		LCD0_D13	2		O				
		LVDS1_VN1	3		O				
		Reserved	4		NA				
		Reserved	5		NA				
		Reserved	6		NA				
		IO Disable	7		OFF				
N3	PD14	Input	0	Function7	I	Z	PU/PD	6	VCC-PD
		Output	1		O				
		LCD0_D14	2		O				
		LVDS1_VP2	3		O				
		Reserved	4		NA				
		Reserved	5		NA				
		Reserved	6		NA				
		IO Disable	7		OFF				
N4	PD15	Input	0	Function7	I	Z	PU/PD	6	VCC-PD
		Output	1		O				
		LCD0_D15	2		O				
		LVDS1_VN2	3		O				
		Reserved	4		NA				
		Reserved	5		NA				
		Reserved	6		NA				
		IO Disable	7		OFF				
P5	PD16	Input	0	Function7	I	Z	PU/PD	6	VCC-PD
		Output	1		O				
		LCD0_D16	2		O				
		LVDS1_VPC	3		O				
		Reserved	4		NA				
		Reserved	5		NA				
		Reserved	6		NA				
		IO Disable	7		OFF				
P4	PD17	Input	0	Function7	I	Z	PU/PD	6	VCC-PD
		Output	1		O				
		LCD0_D17	2		O				
		LVDS1_VNC	3		O				
		Reserved	4		NA				
		Reserved	5		NA				
		Reserved	6		NA				
		IO Disable	7		OFF				

Ball# ⁽¹⁾	Pin Name ⁽²⁾	Signal Name ⁽³⁾	Function ⁽⁴⁾	Ball Reset Rel. Function ⁽⁵⁾	Type ⁽⁶⁾	Ball Reset State ⁽⁷⁾	Pull Up/Down ⁽⁸⁾	Buffer Strength ⁽⁹⁾ (mA)	Power Supply ⁽¹⁰⁾
R5	PD18	Input	0	Function7	I	Z	PU/PD	6	VCC-PD
		Output	1		O				
		LCD0_D18	2		O				
		LVDS1_VP3	3		O				
		Reserved	4		NA				
		Reserved	5		NA				
		Reserved	6		NA				
		IO Disable	7		OFF				
R4	PD19	Input	0	Function7	I	Z	PU/PD	6	VCC-PD
		Output	1		O				
		LCD0_D19	2		O				
		LVDS1_VN3	3		O				
		Reserved	4		NA				
		Reserved	5		NA				
		Reserved	6		NA				
		IO Disable	7		OFF				
T2	PD20	Input	0	Function7	I	Z	PU/PD	6	VCC-PD
		Output	1		O				
		LCD0_D20	2		O				
		CSI1_MCLK	3		O				
		Reserved	4		NA				
		Reserved	5		NA				
		Reserved	6		NA				
		IO Disable	7		OFF				
U1	PD21	Input	0	Function7	I	Z	PU/PD	6	VCC-PD
		Output	1		O				
		LCD0_D21	2		O				
		SMC_VPPEN	3		O				
		Reserved	4		NA				
		Reserved	5		NA				
		Reserved	6		NA				
		IO Disable	7		OFF				
U2	PD22	Input	0	Function7	I	Z	PU/PD	6	VCC-PD
		Output	1		O				
		LCD0_D22	2		O				
		SMC_VPPPP	3		O				
		Reserved	4		NA				
		Reserved	5		NA				
		Reserved	6		NA				
		IO Disable	7		OFF				
T3	PD23	Input	0	Function7	I	Z	PU/PD	6	VCC-PD
		Output	1		O				
		LCD0_D23	2		O				
		SMC_DET	3		I				
		Reserved	4		NA				
		Reserved	5		NA				
		Reserved	6		NA				
		IO Disable	7		OFF				
T4	PD24	Input	0	Function7	I	Z	PU/PD	6	VCC-PD
		Output	1		O				
		LCD0_CLK	2		O				
		SMC_VCCEN	3		O				
		Reserved	4		NA				
		Reserved	5		NA				
		Reserved	6		NA				
		IO Disable	7		OFF				
T5	PD25	Input	0	Function7	I	Z	PU/PD	6	VCC-PD
		Output	1		O				
		LCD0_DE	2		O				
		SMC_RST	3		O				
		Reserved	4		NA				
		Reserved	5		NA				
		Reserved	6		NA				
		IO Disable	7		OFF				

Ball# ⁽¹⁾	Pin Name ⁽²⁾	Signal Name ⁽³⁾	Function ⁽⁴⁾	Ball Reset Rel. Function ⁽⁵⁾	Type ⁽⁶⁾	Ball Reset State ⁽⁷⁾	Pull Up/Down ⁽⁸⁾	Buffer Strength ⁽⁹⁾ (mA)	Power Supply ⁽¹⁰⁾
U5	PD26	Input	0	Function7	I	Z	PU/PD	6	VCC-PD
		Output	1		O				
		LCD0_HSYNC	2		O				
		SMC_SLK	3		O				
		Reserved	4		NA				
		Reserved	5		NA				
		Reserved	6		NA				
		IO Disable	7		OFF				
U6	PD27	Input	0	Function7	I	Z	PU/PD	6	VCC-PD
		Output	1		O				
		LCD0_VSYNC	2		O				
		SMC_SDA	3		I/O				
		Reserved	4		NA				
		Reserved	5		NA				
		Reserved	6		NA				
		IO Disable	7		OFF				
N7,N8	VCC-PD	VCC-PD	NA	NA	P	NA	NA	NA	NA
GPIOE									
AA17	PE0	Input	0	Function7	I	Z	PU/PD	6	VCC-PE
		Output	1		O				
		TS0_CLK	2		I				
		CSIO_PCLK	3		I				
		Reserved	4		NA				
		Reserved	5		NA				
		Reserved	6		NA				
		IO Disable	7		OFF				
Y17	PE1	Input	0	Function7	I	Z	PU/PD	6	VCC-PE
		Output	1		O				
		TS0_ERR	2		I				
		CSIO_MCLK	3		O				
		Reserved	4		NA				
		Reserved	5		NA				
		Reserved	6		NA				
		IO Disable	7		OFF				
W17	PE2	Input	0	Function7	I	Z	PU/PD	6	VCC-PE
		Output	1		O				
		TS0_SYNC	2		I				
		CSIO_HSYNC	3		I				
		Reserved	4		NA				
		Reserved	5		NA				
		Reserved	6		NA				
		IO Disable	7		OFF				
W19	PE3	Input	0	Function7	I	Z	PU/PD	6	VCC-PE
		Output	1		O				
		TS0_DVLD	2		I				
		CSIO_VSYNC	3		I				
		Reserved	4		NA				
		Reserved	5		NA				
		Reserved	6		NA				
		IO Disable	7		OFF				
Y19	PE4	Input	0	Function7	I	Z	PU/PD	6	VCC-PE
		Output	1		O				
		TS0_D0	2		I				
		CSIO_D0	3		I				
		Reserved	4		NA				
		Reserved	5		NA				
		Reserved	6		NA				
		IO Disable	7		OFF				
AA19	PE5	Input	0	Function7	I	Z	PU/PD	6	VCC-PE
		Output	1		O				
		TS0_D1	2		I				
		CSIO_D1	3		I				
		Reserved	4		NA				
		Reserved	5		NA				

Ball# ⁽¹⁾	Pin Name ⁽²⁾	Signal Name ⁽³⁾	Function ⁽⁴⁾	Ball Reset Rel. Function ⁽⁵⁾	Type ⁽⁶⁾	Ball Reset State ⁽⁷⁾	Pull Up/Down ⁽⁸⁾	Buffer Strength ⁽⁹⁾ (mA)	Power Supply ⁽¹⁰⁾
		Reserved	6		NA				
		IO Disable	7		OFF				
AB19	PE6	Input	0	Function7	I	Z	PU/PD	6	VCC-PE
		Output	1		O				
		TS0_D2	2		I				
		CSIO_D2	3		I				
		Reserved	4		NA				
		Reserved	5		NA				
		Reserved	6		NA				
		IO Disable	7		OFF				
AC19	PE7	Input	0	Function7	I	Z	PU/PD	6	VCC-PE
		Output	1		O				
		TS0_D3	2		I				
		CSIO_D3	3		I				
		Reserved	4		NA				
		Reserved	5		NA				
		Reserved	6		NA				
		IO Disable	7		OFF				
AD19	PE8	Input	0	Function7	I	Z	PU/PD	6	VCC-PE
		Output	1		O				
		TS0_D4	2		I				
		CSIO_D4	3		I				
		Reserved	4		NA				
		Reserved	5		NA				
		Reserved	6		NA				
		IO Disable	7		OFF				
AD20	PE9	Input	0	Function7	I	Z	PU/PD	6	VCC-PE
		Output	1		O				
		TS0_D5	2		I				
		CSIO_D5	3		I				
		Reserved	4		NA				
		Reserved	5		NA				
		Reserved	6		NA				
		IO Disable	7		OFF				
AB20	PE10	Input	0	Function7	I	Z	PU/PD	6	VCC-PE
		Output	1		O				
		TS0_D6	2		I				
		CSIO_D6	3		I				
		Reserved	4		NA				
		Reserved	5		NA				
		Reserved	6		NA				
		IO Disable	7		OFF				
AC20	PE11	Input	0	Function7	I	Z	PU/PD	6	VCC-PE
		Output	1		O				
		TS0_D7	2		I				
		CSIO_D7	3		I				
		Reserved	4		NA				
		Reserved	5		NA				
		Reserved	6		NA				
		IO Disable	7		OFF				
U17	VCC-PE	VCC-PE	NA	NA	P	NA	NA	NA	NA
GPIOF									
AA11	PF0	Input	0	Function7	I	Z	PU/PD	6	VCC-PF
		Output	1		O				
		SDC0_D1	2		I/O				
		Reserved	3		NA				
		JTAG_MS1	4		I				
		Reserved	5		NA				
		Reserved	6		NA				
		IO Disable	7		OFF				
Y11	PF1	Input	0	Function7	I	Z	PU/PD	6	VCC-PF
		Output	1		O				
		SDC0_D0	2		I/O				
		Reserved	3		NA				

Ball# ⁽¹⁾	Pin Name ⁽²⁾	Signal Name ⁽³⁾	Function ⁽⁴⁾	Ball Reset Rel. Function ⁽⁵⁾	Type ⁽⁶⁾	Ball Reset State ⁽⁷⁾	Pull Up/Down ⁽⁸⁾	Buffer Strength ⁽⁹⁾ (mA)	Power Supply ⁽¹⁰⁾
		JTAG_DI1	4		I				
		Reserved	5		NA				
		Reserved	6		NA				
		IO Disable	7		OFF				
W11	PF2	Input	0	Function7	I	Z	PU/PD	6	VCC-PF
		Output	1		O				
		SDC0_CLK	2		O				
		Reserved	3		NA				
		UART0_TX	4		O				
		Reserved	5		NA				
		Reserved	6		NA				
IO Disable	7	OFF							
AA13	PF3	Input	0	Function7	I	Z	PU/PD	6	VCC-PF
		Output	1		O				
		SDC0_CMD	2		I/O				
		Reserved	3		NA				
		JTAG_DO1	4		O				
		Reserved	5		NA				
		Reserved	6		NA				
IO Disable	7	OFF							
Y13	PF4	Input	0	Function7	I	Z	PU/PD	6	VCC-PF
		Output	1		O				
		SDC0_D3	2		I/O				
		Reserved	3		NA				
		UART0_RX	4		I				
		Reserved	5		NA				
		Reserved	6		NA				
IO Disable	7	OFF							
W13	PF5	Input	0	Function7	I	Z	PU/PD	6	VCC-PF
		Output	1		O				
		SDC0_D2	2		I/O				
		Reserved	3		NA				
		JTAG_CK1	4		I				
		Reserved	5		NA				
		Reserved	6		NA				
IO Disable	7	OFF							
T12	VCC-PF	VCC-PF	NA	NA	P	NA	NA	NA	NA
GPIOG									
AA20	PG0	Input	0	Function7	I	Z	PU/PD	6	VCC-PG
		Output	1		O				
		TS1_CLK	2		I				
		CSI1_PCLK	3		I				
		SDC1_CMD	4		I/O				
		Reserved	5		NA				
		Reserved	6		NA				
IO Disable	7	OFF							
Y20	PG1	Input	0	Function7	I	Z	PU/PD	6	VCC-PG
		Output	1		O				
		TS1_ERR	2		I				
		CSI1_MCLK	3		O				
		SDC1_CLK	4		O				
		Reserved	5		NA				
		Reserved	6		NA				
IO Disable	7	OFF							
AB21	PG2	Input	0	Function7	I	Z	PU/PD	6	VCC-PG
		Output	1		O				
		TS1_SYNC	2		I				
		CSI1_HSYNC	3		I				
		SDC1_D0	4		I/O				
		Reserved	5		NA				
		Reserved	6		NA				
IO Disable	7	OFF							
AC21	PG3	Input	0	Function7	I	Z	PU/PD	6	VCC-PG
		Output	1		O				

Ball# ⁽¹⁾	Pin Name ⁽²⁾	Signal Name ⁽³⁾	Function ⁽⁴⁾	Ball Reset Rel. Function ⁽⁵⁾	Type ⁽⁶⁾	Ball Reset State ⁽⁷⁾	Pull Up/Down ⁽⁸⁾	Buffer Strength ⁽⁹⁾ (mA)	Power Supply ⁽¹⁰⁾
		TS1_DVLD	2		I				
		CSI1_VSYNC	3		I				
		SDC1_D1	4		I/O				
		Reserved	5		NA				
		Reserved	6		NA				
		IO Disable	7		OFF				
AB22	PG4	Input	0	Function7	I	Z	PU/PD	6	VCC-PG
		Output	1		O				
		TS1_D0	2		I				
		CSI1_D0	3		I				
		SDC1_D2	4		I/O				
		CSIO_D8	5		I				
		Reserved	6		NA				
		IO Disable	7		OFF				
AC22	PG5	Input	0	Function7	I	Z	PU/PD	6	VCC-PG
		Output	1		O				
		TS1_D1	2		I				
		CSI1_D1	3		I				
		SDC1_D3	4		I/O				
		CSIO_D9	5		I				
		Reserved	6		NA				
		IO Disable	7		OFF				
AD22	PG6	Input	0	Function7	I	Z	PU/PD	6	VCC-PG
		Output	1		O				
		TS1_D2	2		I				
		CSI1_D2	3		I				
		UART3_TX	4		O				
		CSIO_D10	5		I				
		Reserved	6		NA				
		IO Disable	7		OFF				
AD23	PG7	Input	0	Function7	I	Z	PU/PD	6	VCC-PG
		Output	1		O				
		TS1_D3	2		I				
		CSI1_D3	3		I				
		UART3_RX	4		I				
		CSIO_D11	5		I				
		Reserved	6		NA				
		IO Disable	7		OFF				
AC23	PG8	Input	0	Function7	I	Z	PU/PD	6	VCC-PG
		Output	1		O				
		TS1_D4	2		I				
		CSI1_D4	3		I				
		UART3_RTS	4		O				
		CSIO_D12	5		I				
		Reserved	6		NA				
		IO Disable	7		OFF				
AC24	PG9	Input	0	Function7	I	Z	PU/PD	6	VCC-PG
		Output	1		O				
		TS1_D5	2		I				
		CSI1_D5	3		I				
		UART3_CTS	4		I				
		CSIO_D13	5		I				
		BIST_RESULT0	6		I/O				
		IO Disable	7		OFF				
AB23	PG10	Input	0	Function7	I	Z	PU/PD	6	VCC-PG
		Output	1		O				
		TS1_D6	2		I				
		CSI1_D6	3		I				
		UART4_TX	4		O				
		CSIO_D14	5		I				
		BIST_RESULT1	6		I/O				
		IO Disable	7		OFF				
AB24	PG11	Input	0	Function7	I	Z	PU/PD	6	VCC-PG
		Output	1		O				

Ball# ⁽¹⁾	Pin Name ⁽²⁾	Signal Name ⁽³⁾	Function ⁽⁴⁾	Ball Reset Rel. Function ⁽⁵⁾	Type ⁽⁶⁾	Ball Reset State ⁽⁷⁾	Pull Up/Down ⁽⁸⁾	Buffer Strength ⁽⁹⁾ (mA)	Power Supply ⁽¹⁰⁾
		TS1_D7	2		I				
		CSI1_D7	3		I				
		UART4_RX	4		I				
		CSIO_D15	5		I				
		Reserved	6		NA				
		IO Disable	7		OFF				
T17	VCC-PG	VCC-PG	NA	NA	P	NA	NA	NA	NA
GPIOH									
D23	PH0	Input	0	Function3	I	Z	PU/PD	6	VCC-IO
		Output	1		O				
		LCD1_D0	2		O				
		IO Disable	3		OFF				
		UART3_TX	4		O				
		Reserved	5		NA				
		EINT0	6		I				
		CSI1_D0	7		I				
E23	PH1	Input	0	Function3	I	Z	PU/PD	6	VCC-IO
		Output	1		O				
		LCD1_D1	2		O				
		IO Disable	3		OFF				
		UART3_RX	4		I				
		Reserved	5		NA				
		EINT1	6		I				
		CSI1_D1	7		I				
D24	PH2	Input	0	Function3	I	Z	PU/PD	6	VCC-IO
		Output	1		O				
		LCD1_D2	2		O				
		IO Disable	3		OFF				
		UART3_RTS	4		O				
		Reserved	5		NA				
		EINT2	6		I				
		CSI1_D2	7		I				
E22	PH3	Input	0	Function3	I	Z	PU/PD	6	VCC-IO
		Output	1		O				
		LCD1_D3	2		O				
		IO Disable	3		OFF				
		UART3_CTS	4		I				
		Reserved	5		NA				
		EINT3	6		I				
		CSI1_D3	7		I				
C23	PH4	Input	0	Function3	I	Z	PU/PD	6	VCC-IO
		Output	1		O				
		LCD1_D4	2		O				
		IO Disable	3		OFF				
		UART4_TX	4		O				
		Reserved	5		NA				
		EINT4	6		I				
		CSI1_D4	7		I				
C24	PH5	Input	0	Function3	I	Z	PU/PD	6	VCC-IO
		Output	1		O				
		LCD1_D5	2		O				
		IO Disable	3		OFF				
		UART4_RX	4		I				
		Reserved	5		NA				
		EINT5	6		I				
		CSI1_D5	7		I				
B24	PH6	Input	0	Function3	I	Z	PU/PD	6	VCC-IO
		Output	1		O				
		LCD1_D6	2		O				
		IO Disable	3		OFF				
		UART5_TX	4		O				
		Reserved	5		NA				
		EINT6	6		I				
		CSI1_D6	7		I				

Ball# ⁽¹⁾	Pin Name ⁽²⁾	Signal Name ⁽³⁾	Function ⁽⁴⁾	Ball Reset Rel. Function ⁽⁵⁾	Type ⁽⁶⁾	Ball Reset State ⁽⁷⁾	Pull Up/Down ⁽⁸⁾	Buffer Strength ⁽⁹⁾ (mA)	Power Supply ⁽¹⁰⁾
B22	PH7	Input	0	Function3	I	Z	PU/PD	6	VCC-IO
		Output	1		O				
		LCD1_D7	2		O				
		IO Disable	3		OFF				
		UART5_RX	4		I				
		Reserved	5		NA				
		EINT7	6		I				
		CSI1_D7	7		I				
B23	PH8	Input	0	Function0	I	Z	PU/PD	6	VCC-IO
		Output	1		O				
		LCD1_D8	2		O				
		ERXD3	3		I				
		KP_IN0	4		I				
		Reserved	5		NA				
		EINT8	6		I				
		CSI1_D8	7		I				
A23	PH9	Input	0	Function0	I	Z	PU/PD	6	VCC-IO
		Output	1		O				
		LCD1_D9	2		O				
		ERXD2	3		I				
		KP_IN1	4		I				
		Reserved	5		NA				
		EINT9	6		I				
		CSI1_D9	7		I				
A22	PH10	Input	0	Function0	I	Z	PU/PD	6	VCC-IO
		Output	1		O				
		LCD1_D10	2		O				
		ERXD1	3		I				
		KP_IN2	4		I				
		Reserved	5		NA				
		EINT10	6		I				
		CSI1_D10	7		I				
C21	PH11	Input	0	Function0	I	Z	PU/PD	6	VCC-IO
		Output	1		O				
		LCD1_D11	2		O				
		ERXD0	3		I				
		KP_IN3	4		I				
		Reserved	5		NA				
		EINT11	6		I				
		CSI1_D11	7		I				
D22	PH12	Input	0	Function3	I	Z	PU/PD	6	VCC-IO
		Output	1		O				
		LCD1_D12	2		O				
		IO Disable	3		OFF				
		PS2_SCK1	4		I/O				
		Reserved	5		NA				
		EINT12	6		I				
		CSI1_D12	7		I				
C22	PH13	Input	0	Function3	I	Z	PU/PD	6	VCC-IO
		Output	1		O				
		LCD1_D13	2		O				
		IO Disable	3		OFF				
		PS2_SDA1	4		I/O				
		SMC_RST	5		O				
		EINT13	6		I				
		CSI1_D13	7		I				
B21	PH14	Input	0	Function0	I	Z	PU/PD	6	VCC-IO
		Output	1		O				
		LCD1_D14	2		O				
		ETXD3	3		O				
		KP_IN4	4		I				
		SMC_VPPEN	5		O				
		EINT14	6		I				
		CSI1_D14	7		I				

Ball# ⁽¹⁾	Pin Name ⁽²⁾	Signal Name ⁽³⁾	Function ⁽⁴⁾	Ball Reset Rel. Function ⁽⁵⁾	Type ⁽⁶⁾	Ball Reset State ⁽⁷⁾	Pull Up/Down ⁽⁸⁾	Buffer Strength ⁽⁹⁾ (mA)	Power Supply ⁽¹⁰⁾
A21	PH15	Input	0	Function0	I	Z	PU/PD	6	VCC-IO
		Output	1		O				
		LCD1_D15	2		O				
		ETXD2	3		O				
		KP_IN5	4		I				
		SMC_VPPPP	5		O				
		EINT15	6		I				
		CSI1_D15	7		I				
D21	PH16	Input	0	Function5	I	Z	PU/PD	6	VCC-IO
		Output	1		O				
		LCD1_D16	2		O				
		ETXD1	3		O				
		KP_IN6	4		I				
		SMC_DET	5		I				
		EINT16	6		I				
		CSI1_D16	7		I				
D18	PH17	Input	0	Function0	I	Z	PU/PD	6	VCC-IO
		Output	1		O				
		LCD1_D17	2		O				
		ETXD0	3		O				
		KP_IN7	4		I				
		SMC_VCCEN	5		O				
		EINT17	6		I				
		CSI1_D17	7		I				
C18	PH18	Input	0	Function0	I	Z	PU/PD	6	VCC-IO
		Output	1		O				
		LCD1_D18	2		O				
		ERXCK	3		I				
		KP_OUT0	4		O				
		SMC_SLK	5		O				
		EINT18	6		I				
		CSI1_D18	7		I				
E19	PH19	Input	0	Function0	I	Z	PU/PD	6	VCC-IO
		Output	1		O				
		LCD1_D19	2		O				
		ERXERR	3		I				
		KP_OUT1	4		O				
		SMC_SDA	5		I/O				
		EINT19	6		I				
		CSI1_D19	7		I				
F18	PH20	Input	0	Function5	I	Z	PU/PD	6	VCC-IO
		Output	1		O				
		LCD1_D20	2		O				
		ERXDV	3		I				
		Reserved	4		O				
		IO Disable	5		OFF				
		EINT20	6		I				
		CSI1_D20	7		I				
D19	PH21	Input	0	Function5	I	Z	PU/PD	6	VCC-IO
		Output	1		O				
		LCD1_D21	2		O				
		EMDC	3		O				
		Reserved	4		I				
		IO Disable	5		OFF				
		EINT21	6		I				
		CSI1_D21	7		I				
G17	PH22	Input	0	Function6	I	Z	PU/PD	6	VCC-IO
		Output	1		O				
		LCD1_D22	2		O				
		EMDIO	3		I/O				
		KP_OUT2	4		O				
		SDC1_CMD	5		I/O				
		IO Disable	6		OFF				
		CSI1_D22	7		I				

Ball# ⁽¹⁾	Pin Name ⁽²⁾	Signal Name ⁽³⁾	Function ⁽⁴⁾	Ball Reset Rel. Function ⁽⁵⁾	Type ⁽⁶⁾	Ball Reset State ⁽⁷⁾	Pull Up/Down ⁽⁸⁾	Buffer Strength ⁽⁹⁾ (mA)	Power Supply ⁽¹⁰⁾
C19	PH23	Input	0	Function6	I	Z	PU/PD	6	VCC-IO
		Output	1		O				
		LCD1_D23	2		O				
		ETXEN	3		O				
		KP_OUT3	4		O				
		SDC1_CLK	5		O				
		IO Disable	6		OFF				
		CSI1_D23	7		I				
B18	PH24	Input	0	Function6	I	Z	PU/PD	6	VCC-IO
		Output	1		O				
		LCD1_CLK	2		O				
		ETXCK	3		I				
		KP_OUT4	4		O				
		SDC1_D0	5		I/O				
		IO Disable	6		OFF				
		CSI1_PCLK	7		I				
E18	PH25	Input	0	Function6	I	Z	PU/PD	6	VCC-IO
		Output	1		O				
		LCD1_DE	2		O				
		ECRS	3		I				
		KP_OUT5	4		O				
		SDC1_D1	5		I/O				
		IO Disable	6		OFF				
		CSI1_FIELD	7		I/O				
A18	PH26	Input	0	Function6	I	Z	PU/PD	6	VCC-IO
		Output	1		O				
		LCD1_HSYNC	2		O				
		ECOL	3		I				
		KP_OUT6	4		O				
		SDC1_D2	5		I/O				
		IO Disable	6		OFF				
		CSI1_HSYNC	7		I				
B19	PH27	Input	0	Function6	I	Z	PU/PD	6	VCC-IO
		Output	1		O				
		LCD1_VSYNC	2		O				
		ETXERR	3		O				
		KP_OUT7	4		O				
		SDC1_D3	5		I/O				
		IO Disable	6		OFF				
		CSI1_VSYNC	7		I				
GPIO I									
AA22	PIO	Input	0	Function7	I	Z	PU/PD	6	VCC-IO
		Output	1		O				
		Reserved	2		NA				
		TWI3_SCK	3		I/O				
		Reserved	4		NA				
		Reserved	5		NA				
		Reserved	6		NA				
		IO Disable	7		OFF				
AA23	PI1	Input	0	Function7	I	Z	PU/PD	6	VCC-IO
		Output	1		O				
		Reserved	2		NA				
		TWI3_SDA	3		I/O				
		Reserved	4		NA				
		Reserved	5		NA				
		Reserved	6		NA				
		IO Disable	7		OFF				
AA24	PI2	Input	0	Function7	I	Z	PU/PD	6	VCC-IO
		Output	1		O				
		Reserved	2		NA				
		TWI4_SCK	3		I/O				
		Reserved	4		NA				
		Reserved	5		NA				
		Reserved	6		NA				

Ball# ⁽¹⁾	Pin Name ⁽²⁾	Signal Name ⁽³⁾	Function ⁽⁴⁾	Ball Reset Rel. Function ⁽⁵⁾	Type ⁽⁶⁾	Ball Reset State ⁽⁷⁾	Pull Up/Down ⁽⁸⁾	Buffer Strength ⁽⁹⁾ (mA)	Power Supply ⁽¹⁰⁾
		IO Disable	7		OFF				
Y22	PI3	Input	0	Function7	I	Z	PU/PD	6	VCC-IO
		Output	1		O				
		PWM1	2		I/O				
		TWI4_SDA	3		I/O				
		Reserved	4		NA				
		Reserved	5		NA				
		Reserved	6		NA				
		IO Disable	7		OFF				
Y23	PI4	Input	0	Function7	I	Z	PU/PD	6	VCC-IO
		Output	1		O				
		SDC3_CMD	2		I/O				
		Reserved	3		NA				
		Reserved	4		NA				
		Reserved	5		NA				
		Reserved	6		NA				
		IO Disable	7		OFF				
W22	PI5	Input	0	Function7	I	Z	PU/PD	6	VCC-IO
		Output	1		O				
		SDC3_CLK	2		O				
		Reserved	3		NA				
		Reserved	4		NA				
		Reserved	5		NA				
		Reserved	6		NA				
		IO Disable	7		OFF				
W23	PI6	Input	0	Function7	I	Z	PU/PD	6	VCC-IO
		Output	1		O				
		SDC3_D0	2		I/O				
		Reserved	3		NA				
		Reserved	4		NA				
		Reserved	5		NA				
		Reserved	6		NA				
		IO Disable	7		OFF				
W24	PI7	Input	0	Function7	I	Z	PU/PD	6	VCC-IO
		Output	1		O				
		SDC3_D1	2		I/O				
		Reserved	3		NA				
		Reserved	4		NA				
		Reserved	5		NA				
		Reserved	6		NA				
		IO Disable	7		OFF				
W20	PI8	Input	0	Function7	I	Z	PU/PD	6	VCC-IO
		Output	1		O				
		SDC3_D2	2		I/O				
		Reserved	3		NA				
		Reserved	4		NA				
		Reserved	5		NA				
		Reserved	6		NA				
		IO Disable	7		OFF				
V22	PI9	Input	0	Function7	I	Z	PU/PD	6	VCC-IO
		Output	1		O				
		SDC3_D3	2		I/O				
		Reserved	3		NA				
		Reserved	4		NA				
		Reserved	5		NA				
		Reserved	6		NA				
		IO Disable	7		OFF				
V23	PI10	Input	0	Function7	I	Z	PU/PD	6	VCC-IO
		Output	1		O				
		SPIO_CS0	2		I/O				
		UART5_TX	3		O				
		Reserved	4		NA				
		Reserved	5		NA				
		EINT22	6		I				

Ball# ⁽¹⁾	Pin Name ⁽²⁾	Signal Name ⁽³⁾	Function ⁽⁴⁾	Ball Reset Rel. Function ⁽⁵⁾	Type ⁽⁶⁾	Ball Reset State ⁽⁷⁾	Pull Up/Down ⁽⁸⁾	Buffer Strength ⁽⁹⁾ (mA)	Power Supply ⁽¹⁰⁾
		IO Disable	7		OFF				
V24	PI11	Input	0	Function7	I	Z	PU/PD	6	VCC-IO
		Output	1		O				
		SPIO_CLK	2		I/O				
		UART5_RX	3		I				
		Reserved	4		NA				
		Reserved	5		NA				
		EINT23	6		I				
		IO Disable	7		OFF				
U18	PI12	Input	0	Function7	I	Z	PU/PD	6	VCC-IO
		Output	1		O				
		SPIO_MOSI	2		I/O				
		UART6_TX	3		O				
		CLK_OUT_A	4		O				
		Reserved	5		NA				
		EINT24	6		I				
		IO Disable	7		OFF				
V21	PI13	Input	0	Function7	I	Z	PU/PD	6	VCC-IO
		Output	1		O				
		SPIO_MISO	2		I/O				
		UART6_RX	3		I				
		CLK_OUT_B	4		O				
		Reserved	5		NA				
		EINT25	6		I				
		IO Disable	7		OFF				
U23	PI14	Input	0	Function7	I	Z	PU/PD	6	VCC-IO
		Output	1		O				
		SPIO_CS1	2		I/O				
		PS2_SCK1	3		I/O				
		TCLKIN0	4		I				
		Reserved	5		NA				
		EINT26	6		I				
		IO Disable	7		OFF				
U22	PI15	Input	0	Function7	I	Z	PU/PD	6	VCC-IO
		Output	1		O				
		SPI1_CS1	2		I/O				
		PS2_SDA1	3		I/O				
		TCLKIN1	4		I				
		Reserved	5		NA				
		EINT27	6		I				
		IO Disable	7		OFF				
T19	PI16	Input	0	Function7	I	Z	PU/PD	6	VCC-IO
		Output	1		O				
		SPI1_CS0	2		I/O				
		UART2_RTS	3		O				
		Reserved	4		NA				
		Reserved	5		NA				
		EINT28	6		I				
		IO Disable	7		OFF				
T23	PI17	Input	0	Function7	I	Z	PU/PD	6	VCC-IO
		Output	1		O				
		SPI1_CLK	2		I/O				
		UART2_CTS	3		I				
		Reserved	4		NA				
		Reserved	5		NA				
		EINT29	6		I				
		IO Disable	7		OFF				
T24	PI18	Input	0	Function7	I	Z	PU/PD	6	VCC-IO
		Output	1		O				
		SPI1_MOSI	2		I/O				
		UART2_TX	3		O				
		Reserved	4		NA				
		Reserved	5		NA				
		EINT30	6		I				

Ball# ⁽¹⁾	Pin Name ⁽²⁾	Signal Name ⁽³⁾	Function ⁽⁴⁾	Ball Reset Rel. Function ⁽⁵⁾	Type ⁽⁶⁾	Ball Reset State ⁽⁷⁾	Pull Up/Down ⁽⁸⁾	Buffer Strength ⁽⁹⁾ (mA)	Power Supply ⁽¹⁰⁾
		IO Disable	7		OFF				
T22	PI19	Input	0	Function7	I	Z	PU/PD	6	VCC-IO
		Output	1		O				
		SPI1_MISO	2		I/O				
		UART2_RX	3		I				
		Reserved	4		NA				
		Reserved	5		NA				
		EINT31	6		I				
		IO Disable	7		OFF				
T21	PI20	Input	0	Function7	I	Z	PU/PD	6	VCC-IO
		Output	1		O				
		PS2_SCK0	2		I/O				
		UART7_TX	3		O				
		Reserved	4		NA				
		Reserved	5		NA				
		PWM2	6		I/O				
		IO Disable	7		OFF				
R23	PI21	Input	0	Function7	I	Z	PU/PD	6	VCC-IO
		Output	1		O				
		PS2_SDA0	2		I/O				
		UART7_RX	3		I				
		Reserved	4		NA				
		Reserved	5		NA				
		PWM3	6		I/O				
		IO Disable	7		OFF				
System									
C20	NMI	NMI	NA	NA	I	Z	PU/PD	NA	VCC-RTC
R24	RESET	RESET	NA	NA	I	Z	PU/PD	NA	VCC-IO
U12	TEST	TEST	NA	NA	I	PD	PU/PD	NA	VCC-PF
L7	FEL	FEL	NA	NA	I	PU	PU/PD	NA	VCC-PD
K7	JTAG-SEL	JTAG-SEL	NA	NA	I	PU	PU/PD	NA	VCC-PD
ADC									
AD3	KEYADC0	KEYADC0	NA	NA	AI	NA	NA	NA	AVCC
AA4	KEYADC1	KEYADC1	NA	NA	AI	NA	NA	NA	AVCC
TV-OUT									
V1	TVOUT0	TVOUT0	NA	NA	AO	NA	NA	NA	VCC-TVOUT
V2	TVOUT1	TVOUT1	NA	NA	AO	NA	NA	NA	VCC-TVOUT
V3	TVOUT2	TVOUT2	NA	NA	AO	NA	NA	NA	VCC-TVOUT
V4	TVOUT3	TVOUT3	NA	NA	AO	NA	NA	NA	VCC-TVOUT
P8	VCC-TVOUT	VCC-TVOUT	NA	NA	P	NA	NA	NA	NA
N9	GND-TVOUT	GND-TVOUT	NA	NA	G	NA	NA	NA	NA
TV-IN									
W2	TVIN0	TVIN0	NA	NA	AI	NA	NA	NA	VCC-TVIN
Y1	TVIN1	TVIN1	NA	NA	AI	NA	NA	NA	VCC-TVIN
Y2	TVIN2	TVIN2	NA	NA	AI	NA	NA	NA	VCC-TVIN
W3	TVIN3	TVIN3	NA	NA	AI	NA	NA	NA	VCC-TVIN
P7	VCC-TVIN	VCC-TVIN	NA	NA	P	NA	NA	NA	NA
T10	VRP-TVIN	VRP-TVIN	NA	NA	AI	NA	NA	NA	VCC-TVIN
U10	VRN-TVIN	VRN-TVIN	NA	NA	AI	NA	NA	NA	VCC-TVIN
P9	GND-TVIN	GND-TVIN	NA	NA	G	NA	NA	NA	NA
SATA									
AA9	SATA-TXP	SATA-TXP	NA	NA	AO	NA	NA	NA	VDD25-SATA
AB9	SATA-TXM	SATA-TXM	NA	NA	AO	NA	NA	NA	VDD25-SATA
AA8	SATA-RXP	SATA-RXP	NA	NA	AI	NA	NA	NA	VDD25-SATA
AB8	SATA-RXM	SATA-RXM	NA	NA	AI	NA	NA	NA	VDD25-SATA
W10	REXT-SATA	REXT-SATA	NA	NA	AO	NA	NA	NA	VDD25-SATA
AB7	SATA-CLKP	SATA-CLKP	NA	NA	AI	NA	NA	NA	VDD25-SATA
AA7	SATA-CLKM	SATA-CLKM	NA	NA	AI	NA	NA	NA	VDD25-SATA
T9	VDD-SATA	VDD-SATA	NA	NA	P	NA	NA	NA	NA
U9	VDD25-SATA	VDD25-SATA	NA	NA	P	NA	NA	NA	NA
HDMI									
V10	HCEC	HCEC	NA	NA	I/O	NA	NA	NA	VCC-HDMI
U11	HHPD	HHPD	NA	NA	I/O	NA	NA	NA	VCC-HDMI
V9	HSCL	HSCL	NA	NA	O	NA	NA	NA	VCC-HDMI

Ball# ⁽¹⁾	Pin Name ⁽²⁾	Signal Name ⁽³⁾	Function ⁽⁴⁾	Ball Reset Rel. Function ⁽⁵⁾	Type ⁽⁶⁾	Ball Reset State ⁽⁷⁾	Pull Up/Down ⁽⁸⁾	Buffer Strength ⁽⁹⁾ (mA)	Power Supply ⁽¹⁰⁾
W9	HSDA	HSDA	NA	NA	I/O	NA	NA	NA	VCC-HDMI
AD5	HTX0P	HTX0P	NA	NA	AO	NA	NA	NA	VCC-HDMI
AC5	HTX0N	HTX0N	NA	NA	AO	NA	NA	NA	VCC-HDMI
AD6	HTX1P	HTX1P	NA	NA	AO	NA	NA	NA	VCC-HDMI
AC6	HTX1N	HTX1N	NA	NA	AO	NA	NA	NA	VCC-HDMI
AD7	HTX2P	HTX2P	NA	NA	AO	NA	NA	NA	VCC-HDMI
AC7	HTX2N	HTX2N	NA	NA	AO	NA	NA	NA	VCC-HDMI
AD4	HTXCP	HTXCP	NA	NA	AO	NA	NA	NA	VCC-HDMI
AC4	HTXCN	HTXCN	NA	NA	AO	NA	NA	NA	VCC-HDMI
U8	VCC-HDMI	VCC-HDMI	NA	NA	P	NA	NA	NA	NA
MIPI DSI									
L2	MDSI-CKN	MDSI-CKN	NA	NA	AO	NA	NA	NA	VCC-DSI
L1	MDSI-CKP	MDSI-CKP	NA	NA	AO	NA	NA	NA	VCC-DSI
J2	MDSI-D0N	MDSI-D0N	NA	NA	A I/O	NA	NA	NA	VCC-DSI
J1	MDSI-D0P	MDSI-D0P	NA	NA	A I/O	NA	NA	NA	VCC-DSI
K2	MDSI-D1N	MDSI-D1N	NA	NA	AO	NA	NA	NA	VCC-DSI
K1	MDSI-D1P	MDSI-D1P	NA	NA	AO	NA	NA	NA	VCC-DSI
J4	MDSI-D2N	MDSI-D2N	NA	NA	AO	NA	NA	NA	VCC-DSI
J3	MDSI-D2P	MDSI-D2P	NA	NA	AO	NA	NA	NA	VCC-DSI
K4	MDSI-D3N	MDSI-D3N	NA	NA	AO	NA	NA	NA	VCC-DSI
K3	MDSI-D3P	MDSI-D3P	NA	NA	AO	NA	NA	NA	VCC-DSI
L8	VCC-DSI	VCC-DSI	NA	NA	P	NA	NA	NA	NA
TP									
AA6	TPX1	TPX1	NA	NA	AI	NA	NA	NA	AVCC
AB6	TPX2	TPX2	NA	NA	AI	NA	NA	NA	AVCC
AB5	TPY1	TPY1	NA	NA	AI	NA	NA	NA	AVCC
AB4	TPY2	TPY2	NA	NA	AI	NA	NA	NA	AVCC
USB									
AC8	USB0-DM	USB0-DM	NA	NA	A I/O	NA	NA	NA	VCC-USB
AD8	USB0-DP	USB0-DP	NA	NA	A I/O	NA	NA	NA	VCC-USB
AC9	USB1-DM	USB1-DM	NA	NA	A I/O	NA	NA	NA	VCC-USB
AD9	USB1-DP	USB1-DP	NA	NA	A I/O	NA	NA	NA	VCC-USB
AA10	USB2-DM	USB2-DM	NA	NA	A I/O	NA	NA	NA	VCC-USB
AB10	USB2-DP	USB2-DP	NA	NA	A I/O	NA	NA	NA	VCC-USB
T11	VCC-USB	VCC-USB	NA	NA	P	NA	NA	NA	NA
Audio Codec									
V5	PHONEOUTN	PHONEOUTN	NA	NA	AO	NA	NA	NA	AVCC
V6	PHONEOUTP	PHONEOUTP	NA	NA	AO	NA	NA	NA	AVCC
AC2	FMINR	FMINR	NA	NA	AI	NA	NA	NA	AVCC
AC1	FMINL	FMINL	NA	NA	AI	NA	NA	NA	AVCC
AC3	VMIC	VMIC	NA	NA	AO	NA	NA	NA	AVCC
AB3	MICIN1	MICIN1	NA	NA	AI	NA	NA	NA	AVCC
AD2	MICIN2	MICIN2	NA	NA	AI	NA	NA	NA	AVCC
R8	VRA1	VRA1	NA	NA	AO	NA	NA	NA	AVCC
T7	VRA2	VRA2	NA	NA	AO	NA	NA	NA	AVCC
T8	VRP	VRP	NA	NA	AO	NA	NA	NA	AVCC
R7	AVCC	AVCC	NA	NA	P	NA	NA	NA	NA
AB2	LINEINR	LINEINR	NA	NA	AI	NA	NA	NA	AVCC
AA3	LINEINL	LINEINL	NA	NA	AI	NA	NA	NA	AVCC
V7	AGND	AGND	NA	NA	G	NA	NA	NA	NA
AA1	HPOUTR	HPOUTR	NA	NA	AO	NA	NA	NA	VCC-HP
AA2	HPOUTL	HPOUTL	NA	NA	AO	NA	NA	NA	VCC-HP
V8	GND-HP	GND-HP	NA	NA	G	NA	NA	NA	NA
Y3	HPCOM	HPCOM	NA	NA	AO	NA	NA	NA	AVCC
W4	HPCOMFB	HPCOMFB	NA	NA	AI	NA	NA	NA	AVCC
W8	HPBP	HPBP	NA	NA	AO	NA	NA	NA	VCC-HP
R9	VCC-HP	VCC-HP	NA	NA	P	NA	NA	NA	NA
Clock									
A20	X32KIN	X32KIN	NA	NA	AI	NA	NA	NA	VCC-RTC
B20	X32KOUT	X32KOUT	NA	NA	AO	NA	NA	NA	VCC-RTC
H17	VCC-RTC	VCC-RTC	NA	NA	P	NA	NA	NA	NA
H16	RTC-VIO	RTC-VIO	NA	NA	AO	NA	NA	NA	VCC-RTC
AD11	X24MIN	X24MIN	NA	NA	AI	NA	NA	NA	VCC-PLL
AC11	X24MOUT	X24MOUT	NA	NA	AO	NA	NA	NA	VCC-PLL

Ball# ⁽¹⁾	Pin Name ⁽²⁾	Signal Name ⁽³⁾	Function ⁽⁴⁾	Ball Reset Rel. Function ⁽⁵⁾	Type ⁽⁶⁾	Ball Reset State ⁽⁷⁾	Pull Up/Down ⁽⁸⁾	Buffer Strength ⁽⁹⁾ (mA)	Power Supply ⁽¹⁰⁾
T13	VCC-PLL	VCC-PLL	NA	NA	P	NA	NA	NA	NA
Efuse									
M8	VDD-EFUSE	VDD-EFUSE	NA	NA	P	NA	NA	NA	NA
M7	VDD-EFUSEBP	VDD-EFUSEBP	NA	NA	O	NA	NA	NA	NA
Power									
N17	VDD-CPUFB	VDD-CPUFB	NA	NA	O	NA	NA	NA	NA
J15,J16,J17,K16, K17,L16	VCC-IO	VCC-IO	NA	NA	P	NA	NA	NA	NA
N14,N15,N16,P15, P16,P17,R15,R16	VDD-CPU	VDD-CPU	NA	NA	P	NA	NA	NA	NA
M11,M12,N11, N12,P12,R13	VDD-SYS	VDD-SYS	NA	NA	P	NA	NA	NA	NA
Ground									
A1,A24,AB14,AD1, AD24,B12,B8, C10,C15,C17,C4, E10,E13,E16,F10, F11,F12,F14,F17, F5,F7,F8,F9,G10, G13,G7,G8,G9, H11,H14,H15,H2, H4,H6,H8,H9,J10, J11,J12,J13,J14,J7, J9,K10,K11,K12, K13,K14,K15,K8, K9,L10,L11,L12, L13,L14,L15,L9, M10,M13,M14, M15,M16,M17, M9,N10,N13,P10, P11,P13,P14,P18, R10,R11,R12,R14, R17,T16,U13,U14, U16	GND	GND	NA	NA	G	NA	NA	NA	NA

- (1).NA: No Application.
- (2).OFF: Disable IO function of GPIO.
- (3). SA0 and SCAS,SA4 and SA11,SA7 and SBA0,SA15 and SCS1 are 4-pair multiplex pins.
- (4).32 data lines(SDQ[31:0]), 4 data masks(SDQM[3:0]), 4 data strobes differential signals(SDQS[3:0]P/SDQS[3:0]N), can be divided to 4 groups. The data lines can swap each other intra-group or inter-group, but for inter-group swap, data masks and data strobes differential signals also need to swap.
- (5).For SDQ[31:0],SDQM[3:0],SA[15:0],SBA[2:0],SCS[1:0],SCKE[1:0],SODT[1:0],SRAS,SCAS,SWE,SCKP,SCKN, every single-ended characteristics impedance is within (50Ω ±20%).
- (6).The differential characteristics impedance of each pair of differential signals (SCKP/SCKN, SDQS[3:0]P/SDQS[3:0]N) is within (100Ω±20%).
- (7).For LPDDR2 and LPDDR3, SA[15:0] is undefined, SA[15:0] can be floated or connected to GND.
- (8).SRST is only used for DDR3/DDR3L, it can be floated for DDR2/LPDDR2/LPDDR3.
- (9).SZQ is an analog input signal that connects to an external 240Ω -1% grounded resistor which is used to calibrate the DDR PHY impedance.
- (10).SVREF is a reference voltage input used to set the electric level of IO input buffers. For DDR2/DDR3/DDR3L/LPDDR2/LPDDR3, the reference electric level is (VCC-DRAM/2).
- (11).SPI_CS is low active and has an internal pull-up. The signal is suggested to connect to an external pull-up resistor.
- (12).SPI_CLK is used to output clock to SPI flash. Suggest that connect to a 33Ω resistor in series to offer impedance matching and reduce high-frequency radiation.
- (13).SDC2_DS must connect to a 10kΩ external pull-down resistor when eMMC5.0 HS400 mode is used.
- (14).SDC[3:0]_CMD is SD/TF/SDIO/eMMC command signal that must connect to an external pull-up resistor.
- (15).SDC[3:0]_CLK is used to output clock to SD/TF/SDIO/eMMC device. SDC[3:0]_CLK needs to connect to 33Ω resistor in series to offer impedance matching and reduce high-frequency radiation.
- (16).If all IOs of a GPIO port are unused, we suggest that the GPIO port has normal power supply, all IOs shall be floated or connected to GND, and the corresponding register of all IOs can be set to Disable.
- (17).NMI is PMU interrupt input/output signal, and trigger at low level by default. NMI needs to connect to an external pull-up resistor and then connect to VCC-RTC. Suggest that NMI connects to a 1nF capacitor to restrain ESD.
- (18).RESET needs ESD protection and is suggested to connect to a 10kΩ external pull-up resistor.
- (19).TEST is CP test signal that shall be floated.
- (20).The differential characteristics impedance of each pair of differential signals (USB0-DP, USB0-DN, USB1-DP, USB1-DN, USB2-DP, USB2-DN) must be within (90Ω±20%).
- (21).VRA2 connects to a 200kΩ±1% external resistor which is used to calibrate internal circuit.
- (22).AVCC is as the reference voltage of the internal analog circuit, so AVCC shall be ensured ±2% voltage accuracy.
- (23).The external capacitors of AVCC, VRP, VRA1, VRA2 shall be placed near the A40i chip, and in order to reduce loop area, the negative terminals of these capacitors shall be placed near AGND.
- (24).A 10MΩ resistor is connected in parallel between X32KOUT and X32KIN, the resistor can create negative feedback in an inverter to ensure amplifier in linear amplifier region.
- (25).32KFOUT can output 32.768kHz clock by software configuration to provide external Bluetooth to use. The 32KFOUT is open-drain output that connects to a pull-up resistor and then connects to working voltage.
- (26).X24MOUT connects to a 0Ω resistor in series by default, changing the resistor value can adjust clock buffer strength to restrain EMI.

4.2. GPIO Multiplex Function

The following table provides a description of the A40i GPIO multiplex function.



NOTE

For each GPIO, Function0 is input function; Function1 is output function.

Table 4-2. GPIO Multiplex Function

Pin Name	GPIO Group	IO Type	Default Pull-up/down	Function2	Function3	Function4	Function 5	Function 6	Function7
PA0	GPIOA	I/O	No Pull	ERXD3	SPI1_CS0	UART2_RTS	GRXD3	-	-
PA1		I/O	No Pull	ERXD2	SPI1_CLK	UART2_CTS	GRXD2	-	-
PA2		I/O	No Pull	ERXD1	SPI1_MOSI	UART2_TX	GRXD1	-	-
PA3		I/O	No Pull	ERXD0	SPI1_MISO	UART2_RX	GRXD0	-	-
PA4		I/O	No Pull	ETXD3	SPI1_CS1	-	GTXD3	-	-
PA5		I/O	No Pull	ETXD2	SPI3_CS0	-	GTXD2	-	-
PA6		I/O	No Pull	ETXD1	SPI3_CLK	-	GTXD1	-	-
PA7		I/O	No Pull	ETXD0	SPI3_MOSI	-	GTXD0	-	-
PA8		I/O	No Pull	ERXCK	SPI3_MISO	-	GRXCK	-	-
PA9		I/O	No Pull	ERXERR	SPI3_CS1	-	GNUL/ERXERR	I2S1_MCLK	-
PA10		I/O	No Pull	ERXDV	-	UART1_TX	GRXCTL/ERXDV	-	-
PA11		I/O	No Pull	EMDC	-	UART1_RX	GMDC	-	-
PA12		I/O	No Pull	EMDIO	UART6_TX	UART1_RTS	GMDIO	-	-
PA13		I/O	No Pull	ETXEN	UART6_RX	UART1_CTS	GTXCTL/ETXEN	-	-
PA14		I/O	No Pull	ETXCK	UART7_TX	UART1_DTR	GNUL/ETXCK	I2S1_BCLK	-
PA15		I/O	No Pull	ECRS	UART7_RX	UART1_DSR	GTXCK/ECRS	I2S1_LRCK	-
PA16		I/O	No Pull	ECOL	-	UART1_DCD	GCLKIN/ECOL	I2S1_DO	-
PA17	I/O	No Pull	ETXERR	-	UART1_RING	GNUL/ETXERR	I2S1_DI	-	
PB0	GPIOB	I/O	No Pull	TWIO_SCK	PLL_LOCK_DBG	-	-	-	-
PB1		I/O	No Pull	TWIO_SDA	-	-	-	-	-
PB2		I/O	No Pull	-	PWM0	-	-	-	-
PB3		I/O	No Pull	-	PWM1	OWA_MCLK	-	-	-
PB4		I/O	No Pull	CIR0_RX	-	-	-	-	-
PB5		I/O	No Pull	I2S_MCLK	AC97_MCLK	-	-	-	-
PB6		I/O	No Pull	I2S_BCLK	AC97_BCLK	-	-	-	-
PB7		I/O	No Pull	I2S_LRCK	AC97_SYNC	-	-	-	-
PB8		I/O	No Pull	I2S_DO0	AC97_DO	-	-	-	-
PB9		I/O	No Pull	I2S_DO1	-	PWM6	-	-	-
PB10		I/O	No Pull	I2S_DO2	-	PWM7	-	-	-
PB11		I/O	No Pull	I2S_DO3	-	-	-	-	-
PB12		I/O	No Pull	I2S_DI	AC97_DI	-	-	-	-
PB13		I/O	No Pull	SPI2_CS1	-	OWA_DO	-	-	-
PB14		I/O	No Pull	SPI2_CS0	JTAG_MS0	-	-	-	-
PB15		I/O	No Pull	SPI2_CLK	JTAG_CK0	-	-	-	-
PB16	I/O	No Pull	SPI2_MOSI	JTAG_DO0	-	-	-	-	

Pin Name	GPIO Group	IO Type	Default Pull-up/down	Function2	Function3	Function4	Function 5	Function 6	Function7
PB17		I/O	No Pull	SPI2_MISO	JTAG_DIO	-	-	-	-
PB18		I/O	No Pull	TWI1_SCK	-	-	-	-	-
PB19		I/O	No Pull	TWI1_SDA	-	-	-	-	-
PB20		I/O	No Pull	TWI2_SCK	-	PWM4	-	-	-
PB21		I/O	No Pull	TWI2_SDA	-	PWM5	-	-	-
PB22		I/O	No Pull	UART0_TX	-	-	-	-	-
PB23		I/O	No Pull	UART0_RX	CIR1_RX	-	-	-	-
PC0	GPIOC	I/O	No Pull	NWE	SPI0_MOSI	-	-	-	-
PC1		I/O	No Pull	NALE	SPI0_MISO	-	-	-	-
PC2		I/O	No Pull	NCLE	SPI0_CLK	-	-	-	-
PC3		I/O	PU	NCE1	-	-	-	-	-
PC4		I/O	PU	NCE0	-	-	-	-	-
PC5		I/O	No Pull	NRE	SDC2_DS	-	-	-	-
PC6		I/O	PU	NRB0	SDC2_CMD	-	-	-	-
PC7		I/O	PU	NRB1	SDC2_CLK	-	-	-	-
PC8		I/O	No Pull	NDQ0	SDC2_D0	-	-	-	-
PC9		I/O	No Pull	NDQ1	SDC2_D1	-	-	-	-
PC10		I/O	No Pull	NDQ2	SDC2_D2	-	-	-	-
PC11		I/O	No Pull	NDQ3	SDC2_D3	-	-	-	-
PC12		I/O	No Pull	NDQ4	SDC2_D4	-	-	-	-
PC13		I/O	No Pull	NDQ5	SDC2_D5	-	-	-	-
PC14		I/O	No Pull	NDQ6	SDC2_D6	-	-	-	-
PC15		I/O	No Pull	NDQ7	SDC2_D7	-	-	-	-
PC16		I/O	PD	NWP	-	-	-	-	-
PC17		I/O	PU	NCE2	-	-	-	-	-
PC18		I/O	PU	NCE3	-	-	-	-	-
PC19		I/O	No Pull	NCE4	SPI2_CS0	-	-	-	-
PC20		I/O	No Pull	NCE5	SPI2_CLK	-	-	-	-
PC21		I/O	No Pull	NCE6	SPI2_MOSI	-	-	-	-
PC22		I/O	No Pull	NCE7	SPI2_MISO	-	-	-	-
PC23		I/O	PU	-	SPI0_CS0	-	-	-	-
PC24	I/O	No Pull	NDQS	SDC2_RST	-	-	-	-	
PD0	GPIOD	I/O	No Pull	LCD0_D0	LVDS0_VP0	-	-	-	-
PD1		I/O	No Pull	LCD0_D1	LVDS0_VN0	-	-	-	-
PD2		I/O	No Pull	LCD0_D2	LVDS0_VP1	-	-	-	-
PD3		I/O	No Pull	LCD0_D3	LVDS0_VN1	-	-	-	-
PD4		I/O	No Pull	LCD0_D4	LVDS0_VP2	-	-	-	-
PD5		I/O	No Pull	LCD0_D5	LVDS0_VN2	-	-	-	-
PD6		I/O	No Pull	LCD0_D6	LVDS0_VPC	-	-	-	-
PD7		I/O	No Pull	LCD0_D7	LVDS0_VNC	-	-	-	-
PD8		I/O	No Pull	LCD0_D8	LVDS0_VP3	-	-	-	-
PD9		I/O	No Pull	LCD0_D9	LVDS0_VN3	-	-	-	-
PD10		I/O	No Pull	LCD0_D10	LVDS1_VP0	-	-	-	-

Pin Name	GPIO Group	IO Type	Default Pull-up/down	Function2	Function3	Function4	Function 5	Function 6	Function7	
PD11		I/O	No Pull	LCD0_D11	LVDS1_VN0	-	-	-	-	
PD12		I/O	No Pull	LCD0_D12	LVDS1_VP1	-	-	-	-	
PD13		I/O	No Pull	LCD0_D13	LVDS1_VN1	-	-	-	-	
PD14		I/O	No Pull	LCD0_D14	LVDS1_VP2	-	-	-	-	
PD15		I/O	No Pull	LCD0_D15	LVDS1_VN2	-	-	-	-	
PD16		I/O	No Pull	LCD0_D16	LVDS1_VPC	-	-	-	-	
PD17		I/O	No Pull	LCD0_D17	LVDS1_VNC	-	-	-	-	
PD18		I/O	No Pull	LCD0_D18	LVDS1_VP3	-	-	-	-	
PD19		I/O	No Pull	LCD0_D19	LVDS1_VN3	-	-	-	-	
PD20		I/O	No Pull	LCD0_D20	CSI1_MCLK	-	-	-	-	
PD21		I/O	No Pull	LCD0_D21	SMC_VPPEN	-	-	-	-	
PD22		I/O	No Pull	LCD0_D22	SMC_VPPPP	-	-	-	-	
PD23		I/O	No Pull	LCD0_D23	SMC_DET	-	-	-	-	
PD24		I/O	No Pull	LCD0_CLK	SMC_VCCEN	-	-	-	-	
PD25		I/O	No Pull	LCD0_DE	SMC_RST	-	-	-	-	
PD26		I/O	No Pull	LCD0_HSYNC	SMC_SLK	-	-	-	-	
PD27		I/O	No Pull	LCD0_VSYNC	SMC_SDA	-	-	-	-	
PE0		GPIOE	I/O	No Pull	TS0_CLK	CSIO_PCLK	-	-	-	-
PE1			I/O	No Pull	TS0_ERR	CSIO_MCLK	-	-	-	-
PE2			I/O	No Pull	TS0_SYNC	CSIO_HSYNC	-	-	-	-
PE3			I/O	No Pull	TS0_DVLD	CSIO_VSYNC	-	-	-	-
PE4			I/O	No Pull	TS0_D0	CSIO_D0	-	-	-	-
PE5			I/O	No Pull	TS0_D1	CSIO_D1	-	-	-	-
PE6			I/O	No Pull	TS0_D2	CSIO_D2	-	-	-	-
PE7			I/O	No Pull	TS0_D3	CSIO_D3	-	-	-	-
PE8			I/O	No Pull	TS0_D4	CSIO_D4	-	-	-	-
PE9			I/O	No Pull	TS0_D5	CSIO_D5	-	-	-	-
PE10	I/O		No Pull	TS0_D6	CSIO_D6	-	-	-	-	
PE11	I/O	No Pull	TS0_D7	CSIO_D7	-	-	-	-		
PF0	GPIOF	I/O	No Pull	SDC0_D1		JTAG_MS1	-	-	-	
PF1		I/O	No Pull	SDC0_D0		JTAG_DI1	-	-	-	
PF2		I/O	No Pull	SDC0_CLK		UART0_TX	-	-	-	
PF3		I/O	No Pull	SDC0_CMD		JTAG_DO1	-	-	-	
PF4		I/O	No Pull	SDC0_D3		UART0_RX	-	-	-	
PF5		I/O	No Pull	SDC0_D2		JTAG_CK1	-	-	-	
PG0	GPIOG	I/O	No Pull	TS1_CLK	CSI1_PCLK	SDC1_CMD	-	-	-	
PG1		I/O	No Pull	TS1_ERR	CSI1_MCLK	SDC1_CLK	-	-	-	
PG2		I/O	No Pull	TS1_SYNC	CSI1_HSYNC	SDC1_D0	-	-	-	
PG3		I/O	No Pull	TS1_DVLD	CSI1_VSYNC	SDC1_D1	-	-	-	
PG4		I/O	No Pull	TS1_D0	CSI1_D0	SDC1_D2	CSIO_D8	-	-	
PG5		I/O	No Pull	TS1_D1	CSI1_D1	SDC1_D3	CSIO_D9	-	-	
PG6		I/O	No Pull	TS1_D2	CSI1_D2	UART3_TX	CSIO_D10	-	-	
PG7		I/O	No Pull	TS1_D3	CSI1_D3	UART3_RX	CSIO_D11	-	-	

Pin Name	GPIO Group	IO Type	Default Pull-up/down	Function2	Function3	Function4	Function 5	Function 6	Function7
PG8		I/O	No Pull	TS1_D4	CSI1_D4	UART3_RTS	CSI0_D12	-	-
PG9		I/O	No Pull	TS1_D5	CSI1_D5	UART3_CTS	CSI0_D13	BIST_RESULT0	-
PG10		I/O	No Pull	TS1_D6	CSI1_D6	UART4_TX	CSI0_D14	BIST_RESULT1	-
PG11		I/O	No Pull	TS1_D7	CSI1_D7	UART4_RX	CSI0_D15	-	-
PH0	GPIOH	I/O	No Pull	LCD1_D0	-	UART3_TX	-	EINT0	CSI1_D0
PH1		I/O	No Pull	LCD1_D1	-	UART3_RX	-	EINT1	CSI1_D1
PH2		I/O	No Pull	LCD1_D2	-	UART3_RTS	-	EINT2	CSI1_D2
PH3		I/O	No Pull	LCD1_D3	-	UART3_CTS	-	EINT3	CSI1_D3
PH4		I/O	No Pull	LCD1_D4	-	UART4_TX	-	EINT4	CSI1_D4
PH5		I/O	No Pull	LCD1_D5	-	UART4_RX	-	EINT5	CSI1_D5
PH6		I/O	No Pull	LCD1_D6	-	UART5_TX	-	EINT6	CSI1_D6
PH7		I/O	No Pull	LCD1_D7	-	UART5_RX	-	EINT7	CSI1_D7
PH8		I/O	No Pull	LCD1_D8	ERXD3	KP_IN0	-	EINT8	CSI1_D8
PH9		I/O	No Pull	LCD1_D9	ERXD2	KP_IN1	-	EINT9	CSI1_D9
PH10		I/O	No Pull	LCD1_D10	ERXD1	KP_IN2	-	EINT10	CSI1_D10
PH11		I/O	No Pull	LCD1_D11	ERXD0	KP_IN3	-	EINT11	CSI1_D11
PH12		I/O	No Pull	LCD1_D12	-	PS2_SCK1	-	EINT12	CSI1_D12
PH13		I/O	No Pull	LCD1_D13	-	PS2_SDA1	SMC_RST	EINT13	CSI1_D13
PH14		I/O	No Pull	LCD1_D14	ETXD3	KP_IN4	SMC_VPPEN	EINT14	CSI1_D14
PH15		I/O	No Pull	LCD1_D15	ETXD2	KP_IN5	SMC_VPPPP	EINT15	CSI1_D15
PH16		I/O	No Pull	LCD1_D16	ETXD1	KP_IN6	SMC_DET	EINT16	CSI1_D16
PH17		I/O	No Pull	LCD1_D17	ETXD0	KP_IN7	SMC_VCCEN	EINT17	CSI1_D17
PH18		I/O	No Pull	LCD1_D18	ERXCK	KP_OUT0	SMC_SLK	EINT18	CSI1_D18
PH19		I/O	No Pull	LCD1_D19	ERXERR	KP_OUT1	SMC_SDA	EINT19	CSI1_D19
PH20		I/O	No Pull	LCD1_D20	ERXDV	-	-	EINT20	CSI1_D20
PH21		I/O	No Pull	LCD1_D21	EMDC	-	-	EINT21	CSI1_D21
PH22		I/O	No Pull	LCD1_D22	EMDIO	KP_OUT2	SDC1_CMD	-	CSI1_D22
PH23		I/O	No Pull	LCD1_D23	ETXEN	KP_OUT3	SDC1_CLK	-	CSI1_D23
PH24		I/O	No Pull	LCD1_CLK	ETXCK	KP_OUT4	SDC1_D0	-	CSI1_PCLK
PH25		I/O	No Pull	LCD1_DE	ECRS	KP_OUT5	SDC1_D1	-	CSI1_FIELD
PH26		I/O	No Pull	LCD1_HSYNC	ECOL	KP_OUT6	SDC1_D2	-	CSI1_HSYNC
PH27	I/O	No Pull	LCD1_VSYNC	ETXERR	KP_OUT7	SDC1_D3	-	CSI1_VSYNC	
PI0	GPIOI	I/O	No Pull	-	TWI3_SCK	-	-	-	-
PI1		I/O	No Pull	-	TWI3_SDA	-	-	-	-
PI2		I/O	No Pull	-	TWI4_SCK	-	-	-	-
PI3		I/O	No Pull	PWM1	TWI4_SDA	-	-	-	-
PI4		I/O	No Pull	SDC3_CMD	-	-	-	-	-
PI5		I/O	No Pull	SDC3_CLK	-	-	-	-	-
PI6		I/O	No Pull	SDC3_D0	-	-	-	-	-
PI7		I/O	No Pull	SDC3_D1	-	-	-	-	-
PI8		I/O	No Pull	SDC3_D2	-	-	-	-	-
PI9		I/O	No Pull	SDC3_D3	-	-	-	-	-
PI10	I/O	No Pull	SPIO_CS0	UART5_TX	-	-	EINT22	-	

Pin Name	GPIO Group	IO Type	Default Pull-up/down	Function2	Function3	Function4	Function 5	Function 6	Function7
PI11		I/O	No Pull	SPI0_CLK	UART5_RX	-	-	EINT23	-
PI12		I/O	No Pull	SPI0_MOSI	UART6_TX	CLK_OUT_A	-	EINT24	-
PI13		I/O	No Pull	SPI0_MISO	UART6_RX	CLK_OUT_B	-	EINT25	-
PI14		I/O	No Pull	SPI0_CS1	PS2_SCK1	TCLKIN0	-	EINT26	-
PI15		I/O	No Pull	SPI1_CS1	PS2_SDA1	TCLKIN1	-	EINT27	-
PI16		I/O	No Pull	SPI1_CS0	UART2_RTS	-	-	EINT28	-
PI17		I/O	No Pull	SPI1_CLK	UART2_CTS	-	-	EINT29	-
PI18		I/O	No Pull	SPI1_MOSI	UART2_TX	-	-	EINT30	-
PI19		I/O	No Pull	SPI1_MISO	UART2_RX	-	-	EINT31	-
PI20		I/O	No Pull	PS2_SCK0	UART7_TX	-	-	PWM2	-
PI21		I/O	No Pull	PS2_SDA0	UART7_RX	-	-	PWM3	-

The RGB output can be multiplexed to BT656 output, so the pin correspondence between LCD0 and BT656 is as follows.

Pin Name	LCD Pin	BT656 Pin
PD3	LCD0_D3	VD0
PD4	LCD0_D4	VD1
PD5	LCD0_D5	VD2
PD6	LCD0_D6	VD3
PD7	LCD0_D7	VD4
PD10	LCD0_D10	VD5
PD11	LCD0_D11	VD6
PD12	LCD0_D12	VD7

4.3. Signal Descriptions

A40i contains many peripheral interfaces. Many of the interfaces can multiplex up to eight functions. Pin-multiplexing configuration can refer to Table 4-1 and Table 4-2. Table 4-3 shows the detailed function description of every signal based on the different interface.

- (1).**Signal Name:** The name of every signal.
- (2).**Description:** The detailed function description of every signal.
- (3).**Type:** Denotes the IO signal direction.

- I (Input),
- O (Output),
- I/O(Input/Output),
- OD(Open-Drain),
- A (Analog),
- AI(Analog Input),
- AO(Analog Output),
- A I/O(Analog Input/Output),
- P (Power),
- G (Ground)

Table 4-3. Signal Descriptions

Pin/Signal Name ⁽¹⁾	Description ⁽²⁾	Type ⁽³⁾
DRAM		
SDQ[31:0]	DRAM Bidirectional Data Line to the Memory Device	I/O
SDQS[3:0]P	DRAM Active-High Bidirectional Data Strokes to the Memory Device	I/O
SDQS[3:0]N	DRAM Active-Low Bidirectional Data Strokes to the Memory Device	I/O
SDQM[3:0]	DRAM Data Mask Signal to the Memory Device	O
SCKP	DRAM Active-High Clock Signal to the Memory Device	O
SCKN	DRAM Active-Low Clock Signal to the Memory Device	O
SCKE[1:0]	DRAM Clock Enable Signal to the Memory Device	O
SA[15:0]	DRAM Address Signal to the Memory Device	O
SBA[2:0]	DRAM Bank Address Signal to the Memory Device	O
SWE	DRAM Write Enable Strobe to the Memory Device	O
SCAS	DRAM Column Address Strobe to the Memory Device	O
SRAS	DRAM Row Address Strobe to the Memory Device	O
SCS0	DRAM Chip Select Signal to the Memory Device	O
SODT[1:0]	DRAM On-Die Termination Output Signal	O
SZQ	DRAM ZQ Calibration(the signal connects to an external reference resistor which is used to calibrate DRAM input/output buffer)	AI
SRST	DRAM Reset Signal to the Memory Device	O
SVREF	DRAM Reference Power	P
VCC-DRAM	DRAM Power Supply	P
System Control		
FEL	Boot Mode Select Jump to the Try Media Boot process (SDC0 -> SPI0 -> eMMC2 -> SDC2 -> NAND Flash) when FEL is high level, or else enter into USB Boot process. For more details, see section 3.4 "System Boot" in the <i>Allwinner A40i User Manual</i> .	I
JTAG-SEL	JTAG Mode Select The signal is used to select the port from which JTAG function outputs. External pull-down: Mandatory output from GPIOB External float: Software selects GPIOF or GPIOB	I
TEST	Test Signal	I
NMI	Non-Maskable Interrupt	I
RESET	Reset Signal	I
Interrupt		
EINT[31:0]	External Interrupt Input	I
JTAG		
JTAG_DO[1:0]	JTAG Data Output	O
JTAG_DI[1:0]	JTAG Data Input	I
JTAG_MS[1:0]	JTAG Mode Select Input	I
JTAG_CK[1:0]	JTAG Clock Input	I
PWM		
PWM[7:0]	Pulse Width Modulation Channel	I/O
CLOCK		
X32KIN	32768Hz Crystal Input	AI
X32KOUT	32768Hz Crystal Drive Output	AO
VCC-RTC	RTC Power Supply	P

Pin/Signal Name ⁽¹⁾	Description ⁽²⁾	Type ⁽³⁾
RTC-VIO	Internal LDO Output Bypass	AO
X24MIN	24MHz Crystal Input	AI
X24MOUT	24MHz Crystal Drive Output	AO
VCC-PLL	PLL Power	P
NAND FLASH		
NDQ[7:0]	Nand Flash Data Bit	I/O
NCE[7:0]	Nand Flash Chip Select	O
NWE	Nand Flash Write Enable	O
NALE	Nand Flash Address Latch Enable	O
NCLE	Nand Flash Command Latch Enable	O
NRE	Nand Flash Read Enable	O
NRB[1:0]	Nand Flash Ready/Busy Status Indicator Signal	I
NWP	Nand Flash Write Protection	O
NDQS	Nand Flash Data Strobe	I/O
LCD(x=[1:0])		
LCDx_D[23:0]	LCD Data Bit	O
LCDx_CLK	LCD Clock Signal	O
LCDx_DE	LCD Data Enable	O
LCDx_HSYNC	LCD Horizontal Sync	O
LCDx_VSYNC	LCD Vertical Sync	O
LVDSx(x=1:0)		
LVDSx_VP[3:0]	LVDSx Data Positive Signal Output	O
LVDSx_VN[3:0]	LVDSx Data Negative Signal Output	O
LVDSx_VPC	LVDSx Clock Positive Output	O
LVDSx_VNC	LVDSx Clock Negative Output	O
HDMI		
HTX0P	HDMI Data0 Positive	AO
HTX0N	HDMI Data0 Negative	AO
HTX1P	HDMI Data1 Positive	AO
HTX1N	HDMI Data1 Negative	AO
HTX2P	HDMI Data2 Positive	AO
HTX2N	HDMI Data2 Negative	AO
HTXCP	HDMI Clock Positive	AO
HTXCN	HDMI Clock Negative	AO
VCC-HDMI	HDMI Power Supply	P
HSCL	HDMI Serial Clock	O
HSDA	HDMI Serial Data	I/O
HHPD	HDMI Hot Plug Detect	I/O
HCEC	HDMI Consumer Electronics Control	I/O
MIPI DSI		
MDSI-CKN	MIPI DSI Differential Clock Negative	AO
MDSI-CKP	MIPI DSI Differential Clock Positive	AO
MDSI-D0N	MIPI DSI Differential Data0 Negative	A I/O
MDSI-D0P	MIPI DSI Differential Data0 Positive	A I/O

Pin/Signal Name ⁽¹⁾	Description ⁽²⁾	Type ⁽³⁾
MDSI-D1N	MIPI DSI Differential Data1 Negative	AO
MDSI-D1P	MIPI DSI Differential Data1 Positive	AO
MDSI-D2N	MIPI DSI Differential Data2 Negative	AO
MDSI-D2P	MIPI DSI Differential Data2 Positive	AO
MDSI-D3N	MIPI DSI Differential Data3 Negative	AO
MDSI-D3P	MIPI DSI Differential Data3 Positive	AO
VCC-DSI	MIPI DSI Power Supply	P
TV-OUT		
TVOUT[3:0]	TV-out Output	AO
VCC-TVOUT	TV-out Power Supply	P
GND-TVOUT	TV-out Ground	G
CSI(x=[1:0])		
CSI0_D[15:0]	CSI0 Data Bit	I
CSI1_D[23:0]	CSI1 Data Bit	I
CSIx_PCLK	CSI Pixel Clock	I
CSIx_MCLK	CSI Master Clock	O
CSIx_HSYNC	CSI Horizontal Sync	I
CSIx_VSYNC	CSI Vertical Sync	I
CSI1_FIELD	CSI Field Indicator	I/O
TV-IN		
TVIN[3:0]	TV-in Input	AI
VCC-TVIN	TV-in Power Supply	P
VRP-TVIN	TV-in Reference Voltage Positive	AI
VRN-TVIN	TV-in Reference Voltage Negative	AI
GND-TVIN	TV-in Ground	G
USB		
USB0-DM	USB0 D- Signal	A I/O
USB0-DP	USB0 D+ Signal	A I/O
USB1-DM	USB1 D- Signal	A I/O
USB1-DP	USB1 D+ Signal	A I/O
USB2-DM	USB2 D- Signal	A I/O
USB2-DP	USB2 D+ Signal	A I/O
VCC-USB	USB Power Supply	P
RTP		
TPX[2:1]	Touch Panel X[2:1] Input	AI
TPY[2:1]	Touch Panel Y[2:1] Input	AI
Audio Codec		
PHONEOUTN	Phone Negative Output	AO
PHONEOUTP	Phone Positive Output	AO
FMINR	FM Right Channel Input	AI
FMINL	FM Left Channel Input	AI
VMIC	Bias Voltage Output for Main Microphone	AO
MICIN[2:1]	Microphone Input	AI
VRA1	Reference Voltage Output	AO

Pin/Signal Name ⁽¹⁾	Description ⁽²⁾	Type ⁽³⁾
VRA2	Reference Voltage Output	AO
AVCC	Analog Power Supply	P
VRP	Reference Voltage Output	AO
LINEINR	Linein Right Channel Input	AI
LINEINL	Linein Left Channel Input	AI
AGND	Analog Ground	G
HPOUTR	Headphone Right Channel Output	AO
HPOUTL	Headphone Left Channel Output	AO
HPCOM	Headphone Common Reference Output	AO
HPCOMFB	Headphone Common Reference Feedback Input	AI
HPBP	Headphone Bypass Output	AO
VCC-HP	Headphone Power Supply	P
GND-HP	Analog Ground	G
KEYADC		
KEYADC[1:0]	ADC Input for Key	AI
EMAC		
ERXD[3:0]	MII Receive Data Bit	I
ETXD[3:0]	MII Transmit Data Bit	O
ERXCK	MII Receive Clock	I
ERXERR	MII Receive Error	I
ERXDV	MII Receive Data Valid	I
EMDC	MII Management Data Clock	O
EMDIO	MII Management Data Input/Output	I/O
ETXEN	MII Transmit Enable	O
ETXCK	MII Transmit Clock	I
ECRS	MII Carrier Sense	I
ECOL	MII Collision Detect	I
ETXERR	MII Transmit Error	O
GMAC		
GRXD[3:0]	RGMII/MII Receive Data	I
GTXD[3:0]	RGMII/MII Transmit Data	O
GRXCK	RGMII/MII Receive Clock	I
GNULL/ERXERR	RGMII Null/MII Receive Error	I
GRXCTL/RXDV	RGMII Receive Control/MII Receive Data Valid	I,I
GMDC	RGMII/MII Management Data Clock	O
GMDIO	RGMII/MII Management Data Input/Output	I/O
GTXCTL/ETXEN	RGMII Transmit Control/MII Transmit Enable	O,O
GNULL/ETXCK	RGMII Null/MII Transmit Clock	I
GTXCK/ECRS	RGMII Transmit Clock/MII Carrier Sense	O,I
GCLKIN/ECOL	RGMII Reference Clock Input/MII Collision Detect	I,I
GNULL/ETXERR	RGMII Null/MII Transmit Error	O
SPI(x=[3:0])		
SPIx_CS[1:0]	SPI Chip Select Signal(active low)	I/O
SPIx_CLK	SPI Clock Signal	I/O

Pin/Signal Name ⁽¹⁾	Description ⁽²⁾	Type ⁽³⁾
SPIx_MOSI	SPI Master Data Out, Slave Data In	I/O
SPIx_MISO	SPI Master Data In, Slave Data Out	I/O
UART		
UART0_TX	UART0 Data Transmit	O
UART0_RX	UART0 Data Receive	I
UART1_TX	UART1 Data Transmit	O
UART1_RX	UART1 Data Receive	I
UART1_RTS	UART1 Data Request to Send	O
UART1_CTS	UART1 Data Clear to Send	I
UART1_DTR	UART1 Data Terminal Ready	O
UART1_DSR	UART1 Data Set Ready	I
UART1_DCD	UART1 Data Carrier Detect	I
UART1_RING	UART1 Data Ring Indicator	I
UART2_TX	UART2 Data Transmit	O
UART2_RX	UART2 Data Receive	I
UART2_RTS	UART2 Data Request to Send	O
UART2_CTS	UART2 Data Clear to Send	I
UART3_TX	UART3 Data Transmit	O
UART3_RX	UART3 Data Receive	I
UART3_RTS	UART3 Data Request to Send	O
UART3_CTS	UART3 Data Clear to Send	I
UART4_TX	UART4 Data Transmit	O
UART4_RX	UART4 Data Receive	I
UART5_TX	UART5 Data Transmit	O
UART5_RX	UART5 Data Receive	I
UART6_TX	UART6 Data Transmit	O
UART6_RX	UART6 Data Receive	I
UART7_TX	UART7 Data Transmit	O
UART7_RX	UART7 Data Receive	I
TWI(x=[4:0])		
TWix_SCK	TWI Clock	I/O
TWix_SDA	TWI Data/Address	I/O
SD/MMC		
SDC0_D[3:0]	SDC0 Data Bit	I/O
SDC0_CLK	SDC0 Clock	O
SDC0_CMD	SDC0 Command Signal	I/O
SDC1_D[3:0]	SDC1 Data Bit	I/O
SDC1_CLK	SDC1 Clock	O
SDC1_CMD	SDC1 Command Signal	I/O
SDC2_D[7:0]	SDC2 Data Bit	I/O
SDC2_CLK	SDC2 Clock	O
SDC2_CMD	SDC2 Command Signal	I/O
SDC2_DS	SDC2 Data Strobe	I
SDC2_RST	SDC2 Reset	O

Pin/Signal Name ⁽¹⁾	Description ⁽²⁾	Type ⁽³⁾
SDC3_D[3:0]	SDC3 Data Bit	I/O
SDC3_CLK	SDC3 Clock	O
SDC3_CMD	SDC3 Command Signal	I/O
KEYPAD		
KP_IN[7:0]	Keypad Data Input	I
KP_OUT[7:0]	Keypad Data Output	O
CIR(x=[1:0])		
CIRx_RX	CIR Data Receive	I
PS2		
PS2_SCK[1:0]	PS2 Clock Signal	I/O
PS2_SDA[1:0]	PS2 Data Signal	I/O
I2S		
I2S_DO[3:0]	I2S Data Output	O
I2S_DI	I2S Data Input	I
I2S_MCLK	I2S Master Clock	O
I2S_BCLK	I2S Bit Clock	I/O
I2S_LRCK	I2S Left/Right Channel Select Clock	I/O
I2S1_DO	I2S1 Data Output	O
I2S1_DI	I2S1 Data Input	I
I2S1_BCLK	I2S1 Bit Clock	I/O
I2S1_LRCK	I2S1 Left/Right Channel Select Clock	I/O
I2S1_MCLK	I2S1 Master Clock	O
AC97		
AC97_DO	AC97 Data Output	O
AC97_DI	AC97 Data Input	I
AC97_MCLK	AC97 Master Clock	O
AC97_BCLK	AC97 Bit Clock	I
AC97_SYNC	AC97 Sync Signal	O
OWA		
OWA_MCLK	OWA Master Clock	O
OWA_DO	OWA Data Output	O
TSC(x=[1:0])		
TSx_D[7:0]	Transport Stream Data	I
TSx_CLK	Transport Stream Clock	I
TSx_ERR	Transport Stream Error Indicate	I
TSx_SYNC	Transport Stream Sync	I
TSx_DVLD	Transport Stream Data Valid	I
SCR		
SMC_RST	Smart Card Reset	O
SMC_VPPEN	Smart Card Program Voltage Enable	O
SMC_VPPPP	Smart Card Program Control	O
SMC_DET	Smart Card Detect	I
SMC_VCCEN	Smart Card Power Enable	O
SMC_SLK	Smart Card Clock	O

Pin/Signal Name ⁽¹⁾	Description ⁽²⁾	Type ⁽³⁾
SMC_SDA	Smart Card Data	I/O
SATA		
SATA-TXP	SATA Positive Data Transmit	AO
SATA-TXM	SATA Negative Data Transmit	AO
SATA-RXP	SATA Positive Data Receive	AI
SATA-RXM	SATA Negative Data Receive	AI
REXT-SATA	SATA Reference	AO
SATA-CLKP	SATA Positive Clock	AI
SATA-CLKM	SATA Negative Clock	AI
VDD-SATA	1.2V SATA Power Supply	P
VDD25-SATA	2.5V SATA Power Supply	P

5. Electrical Characteristics

5.1. Absolute Maximum Ratings

Absolute Maximum Ratings are those values beyond which damage to the device may occur. Table 5-1 specifies the absolute maximum ratings.



CAUTION

Stresses beyond those listed under Table 5-1 may affect reliability or cause permanent damage to the device. These are stress ratings only. Functional operation of the device at these or any other conditions beyond those indicated under Section 5.2, *Recommended Operating Conditions*, is not implied. Exposure to absolute maximum rated conditions for extended periods may affect device reliability.

Table 5-1. Absolute Maximum Ratings

Symbol	Parameter	Min	Max	Unit	
Tstg	Storage Temperature	-40	150	°C	
VCC-IO, VCC-PA, VCC-PC, VCC-PD, VCC-PE, VCC-PF, VCC-PG	DC Supply Voltage for I/O	-0.3	3.96	V	
AVCC	DC Supply Voltage for Analog Part	-0.3	3.6	V	
VCC-DRAM	Power Supply for DRAM	-0.3	2.16	V	
VCC-HDMI	Power Supply for HDMI	-0.3	3.96	V	
VCC-USB	Power Supply for USB	-0.3	3.96	V	
VCC-TVOUT	Power Supply for TV-OUT	-0.3	3.96	V	
VCC-TVIN	Power Supply for TV-IN	-0.3	3.96	V	
VCC-DSI	Power Supply for MIPI DSI	-0.3	3.96	V	
VCC-PLL	Power Supply for PLL	-0.3	3.6	V	
VCC-RTC	Power Supply for RTC	-0.3	3.6	V	
VCC-HP	Power Supply for Headphone	-0.3	3.96	V	
VDD-EFUSE	Power Supply for eFuse	-0.3	3.6	V	
VDD25-SATA	2.5V Power Supply for SATA	-0.3	3.0	V	
VDD-SATA	1.2V Power Supply for SATA	-0.3	1.32	V	
VDD-CPU	Power Supply for CPU	-0.3	1.32	V	
VDD-SYS	Power Supply for System	-0.3	1.32	V	
V _{ESD}	Electrostatic Discharge	Human Body Model(HBM) ⁽¹⁾	-4000	4000	V
		Charged Device Model(CDM) ⁽²⁾	-500	500	V
I _{Latch-up}	Latch-up I-test performance current-pulse injection on each IO pin ⁽³⁾	Pass			
	Latch-up over-voltage performance voltage injection on each IO pin ⁽⁴⁾	Pass			

(1). Test method: JEDEC JS-001-2014(Class-3A). JEDEC document JEP155 states that 500V HBM allows safe manufacturing with a standard ESD control process.

(2). Test method: JEDEC JS-002-2014(Class-2A). JEDEC document JEP157 states that 250V CDM allows safe manufacturing with a standard ESD control process.

(3). Current test performance: Pins stressed per JEDEC JESD78D(Class I, Level A) and passed with I/O pin injection current as defined in JEDEC.

(4). Over voltage performance: Supplies stressed per JEDEC JESD78D(Class I, Level A) and passed voltage injection as defined in JEDEC.

5.2. Recommended Operating Conditions

All A40i modules are used under the operating conditions contained in Table 5-2.



NOTE

Logic functions and parameter values are not assured out of the range specified in the recommended operating conditions.

Table 5-2. Recommended Operating Conditions

Symbol	Parameter	Min	Typ	Max	Unit
Ta	Ambient Operating Temperature	-40	-	85	°C
VCC-IO	Digital GPIO Power for 3.3V Voltage	3.0	3.3	3.6	V
VCC-PA	Power Supply for GPIO A	1.62	1.8	1.98	V
		2.25	2.5	2.75	V
		3.0	3.3	3.6	V
VCC-PC	Power Supply for GPIO C	1.62	1.8	1.98	V
		3.0	3.3	3.6	V
VCC-PD	Power Supply for GPIO D	3.0	3.3	3.6	V
VCC-PE	Power Supply for GPIO E	1.62	1.8	1.98	V
		2.52	2.8	3.08	V
		3.0	3.3	3.6	V
VCC-PF	Power Supply for GPIO F	3.0	3.3	3.6	V
VCC-PG	Power Supply for GPIO G	1.62	1.8	1.98	V
		2.52	2.8	3.08	V
		3.0	3.3	3.6	V
AVCC	DC Supply Voltage for Analog Part	2.94	3.0	3.06	V
VCC-DRAM	Power Supply for DDR2	1.7	1.8	1.9	V
	Power Supply for DDR3	1.425	1.5	1.575	V
	Power Supply for DDR3L	1.283	1.35	1.45	V
	Power Supply for LPDDR2	1.14	1.2	1.3	V
	Power Supply for LPDDR3	1.14	1.2	1.3	V
VCC-USB	Power Supply for USB	3.0	3.3	3.6	V
VCC-HDMI	Power Supply for HDMI	3.24	3.3	3.36	V
VCC-TVOUT	Power Supply for TV-OUT	3.24	3.3	3.36	V
VCC-TVIN	Power Supply for TV-IN	3.24	3.3	3.36	V
VDD-SATA	1.2V Power Supply for SATA	1.0	1.1	1.2	V
VDD25-SATA	2.5V Power Supply for SATA	2.25	2.5	2.75	V
VDD-EFUSE	Power Supply for eFuse	3.0	3.3	3.6	V
VCC-DSI	Power Supply for MIPI DSI	3.0	3.3	3.6	V
VCC-HP	Power Supply for Headphone	3.0	3.3	3.6	V
VCC-PLL	Power Supply for PLL	3.0	-	3.3	V
VCC-RTC	Power Supply for RTC	3.0	-	3.3	V
VDD-CPU	Power Supply for CPU	1.0	1.1	1.3	V
VDD-SYS	Power Supply for System	1.0	1.1	1.3	V

Tj	Junction Temperature Range	-40	-	125	°C
----	----------------------------	-----	---	-----	----

5.3. DC Electrical Characteristics

Table 5-3 summarizes the DC electrical characteristics of A40i.

**Table 5-3. DC Electrical Characteristics
(VCC-IO/VCC-PA/VCC-PC/VCC-PD/VCC-PE/VCC-PF/VCC-PG)**

Parameter	Symbol	Min	Typ	Max	Unit	
Digital GPIO	High-Level Input Voltage	V_{IH}	$0.7 * VCC-IO$	-	$VCC-IO + 0.3$	V
	Low-Level Input Voltage	V_{IL}	-0.3	-	$0.3 * VCC-IO$	V
	Input Pull-up Resistance	R_{PU}	50	100	150	kΩ
	Input Pull-down Resistance	R_{PD}	50	100	150	kΩ
	High-Level Input Current	I_{IH}	-	-	10	μA
	Low-Level Input Current	I_{IL}	-	-	10	μA
	High-Level Output Voltage	V_{OH}	$VCC-IO - 0.3$	-	$VCC-IO$	V
	Low-Level Output Voltage	V_{OL}	0	-	0.2	V
	Tri-State Output Leakage Current	I_{OZ}	-10	-	10	μA
	Input Capacitance	C_{IN}	-	-	5	pF
	Output Capacitance	C_{OUT}	-	-	5	pF

5.4. SDRAM I/O DC Electrical Characteristics

The SDRAM I/O pads support DDR3,DDR3L,LPDDR2,and LPDDR3 operational modes. The SDRAM Controller(DRAMC) is designed to be compatible with JEDEC-compliant SDRAMs. The DRAMC supports the following memory types:

- DDR3 SDRAM compliant to JESD79-3E DDR3 JEDEC standard release July, 2010
- LPDDR2 SDRAM compliant to JESD209-2B LPDDR2 JEDEC standard release June, 2009
- LPDDR3 SDRAM compliant to JESD209-3B LPDDR3 JEDEC standard release August, 2013

Table 5-4. DC Input Logic Level

Characteristics	Symbol	Min	Typ	Max	Unit
DC input logic high	$V_{IH(DC)}$	$VREF + 100$	-	-	mV
DC input logic low	$V_{IL(DC)}$	-	-	$VREF - 100$	mV
Input reference voltage	V_{ref}	$0.49 * VDDQ$	-	$0.51 * VDDQ$	V
Input termination resistance(ODT) to $V_{DDQ}/2$	R_{TT}	60	120	Open	Ω

Table 5-5. Output DC Current Drive

Characteristics	Symbol	Min	Max	Unit
DC output high voltage	V_{OH}	$0.9 * VDDQ$	-	V
DC output low voltage	V_{OL}	-	$0.1 * VDDQ$	V

5.5. SDIO Electrical Parameters

The SDIO electrical parameters are related to different supply voltage.

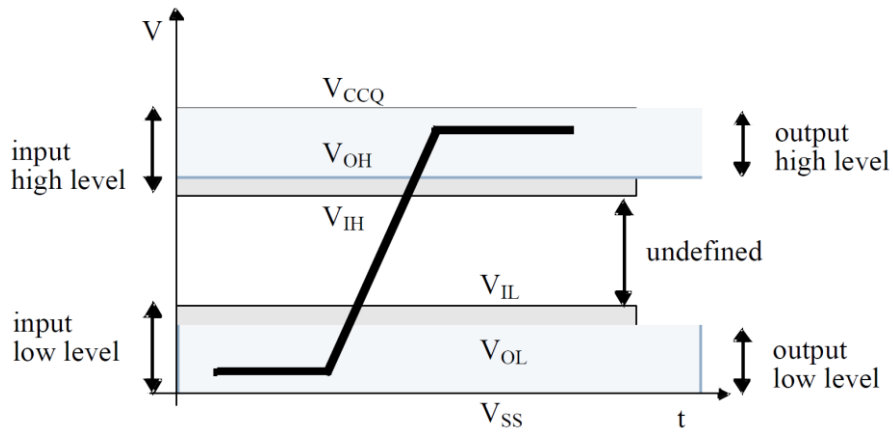

Figure 5-1. SDIO Voltage Waveform

Table 5-6 shows 3.3V SDIO electrical parameters.

Table 5-6. 3.3V SDIO Electrical Parameters

Symbol	Parameter	Min	Typ	Max	Unit
VDD	Power voltage	2.7	-	3.6	V
V _{CCQ}	I/O voltage	2.7		3.6	V
V _{OH}	Output high-level voltage	0.75 * V _{CCQ}	-	-	V
V _{OL}	Output low-level voltage	-	-	0.125 * V _{CCQ}	V
V _{IH}	Input high-level voltage	0.625 * V _{CCQ}	-	V _{CCQ} + 0.3	V
V _{IL}	Input low-level voltage	V _{SS} - 0.3	-	0.25 * V _{CCQ}	V

Table 5-7 shows 1.8V SDIO electrical parameters.

Table 5-7. 1.8V SDIO Electrical Parameters

Symbol	Parameter	Min	Typ	Max	Unit
VDD	Power voltage	2.7	-	3.6	V
V _{CCQ}	I/O voltage	1.7		1.95	V
V _{OH}	Output high-level voltage	V _{CCQ} - 0.45	-	-	V
V _{OL}	Output low-level voltage	-	-	0.45	V
V _{IH}	Input high-level voltage	0.625 * V _{CCQ} ⁽¹⁾	-	V _{CCQ} + 0.3	V
V _{IL}	Input low-level voltage	V _{SS} - 0.3	-	0.35 * V _{CCQ} ⁽²⁾	V

(1).0.7 * V_{CCQ} for MMC4.3 or lower.

(2).0.3 * V_{CCQ} for MMC4.3 or lower.

5.6. Audio Codec Electrical Parameters

Table 5-8 shows audio codec electrical parameters.

Table 5-8. Audio Codec Typical Performance

Parameters	Input Conditions	Typ(L/R channel output)	Unit
DAC To Headphone (32Ω)			
Output Level	0dB 1kHz Sine	620	mVrms
SNR(A-weighted)		98	dB
THD+N		80	dB
DAC To Headphone (16Ω)			
Output Level	0dB 1kHz Sine	530	mVrms

SNR(A-weighted)		97	dB
THD+N		79	dB
DAC To Headphone (No load)			
Output Level		740	mVrms
SNR(A-weighted)	0dB 1kHz Sine	98	dB
THD+N		80	dB
DAC To PHONEOUTDIFF Via Output Mix(No load)			
Output Level		1.78	Vrms
SNR(A-weighted)	0dB 1kHz Sine	100	dB
THD+N		80	dB
DAC To PHONEOUT Via Output Mix(600Ω)			
Output Level		1.18	Vrms
SNR(A-weighted)	0dB 1kHz Sine	98	dB
THD+N		79	dB
DAC To PHONEOUT Via Output Mix(300Ω)			
Output Level		885	Vrms
SNR(A-weighted)	0dB 1kHz Sine	98	dB
THD+N		77	dB
LINEIN ADDA To HPOUT Via Output Mix			
Output Level		610	mVrms
SNR(A-weighted)	2.5Vpp	92	dB
THD+N		81	dB
FMIN ADDA To HPOUT Via Output Mix			
Output Level		627	mVrms
SNR(A-weighted)	2.5Vpp	92	dB
THD+N		83	dB
MIC1-ADDA-PHONEONE			
Output Level		756	mVrms
SNR(A-weighted)	2.5Vpp	93	dB
THD+N		83	dB
MIC2-ADDA-PHONEONE			
Output Level		742	mVrms
SNR(A-weighted)	2.5Vpp	90	dB
THD+N		82	dB
DAC To HP (32Ω)(HP Gain 0x3C)			
FScale Input Level		621	mVrms
SNR(A-weighted)	0dB 1kHz Sine	98	dB
THD+N		80	dB
DAC To HP (16Ω)(HP Gain 0x3B)			
FScale Input Level		529	mVrms
SNR(A-weighted)	0dB 1kHz Sine	97	dB
THD+N		79	dB

5.7. KEYADC Electrical Characteristics

KEYADC contains two-channels analog-to-digital(ADC) converter for key application. Table 5-9 lists KEYADC electrical characteristics.

Table 5-9. KEYADC Electrical Characteristics

Parameter	Min	Typ	Max	Unit
ADC Resolution	-	6	-	bits
Full-scale Input Range	0	-	0.667*AVCC	V
Quantizing Error	-	1	-	LSB
Clock Frequency	-	-	250	Hz
Conversion Time	-	14	-	ADC Clock Cycles

5.8. PLL Electrical Characteristics

5.8.1. CPU PLL Electrical Parameters

Table 5-10. CPU PLL Electrical Parameters

Parameter	Value
Clock Output Range	60MHz ~2.1GHz
Reference Clock	24MHz
Max. Lock Time	1.5ms
Max. Peak-to-Peak Supply Noise	200ps

5.8.2. Audio PLL Electrical Parameters

Table 5-11. Audio PLL Electrical Parameters

Parameter	Value
Clock Output Range	22.5792MHz,24.576MHz
Reference Clock	24MHz
Max. Lock Time	500us
Max. Peak-to-Peak Supply Noise	200ps

5.8.3. GPU PLL Electrical Parameters

Table 5-12. GPU PLL Electrical Parameters

Parameter	Value
Clock Output Range	192MHz~600MHz
Reference Clock	24MHz
Max. Lock Time	500us
Max. Peak-to-Peak Supply Noise	200ps

5.8.4. Peripheral0/1 PLL Electrical Parameters

Table 5-13. Peripheral0/1 PLL Electrical Parameters

Parameter	Value
Clock Output Range	504MHz ~1.4GHz
Reference Clock	24MHz
Max. Lock Time	500us
Max. Peak-to-Peak Supply Noise	200ps

5.8.5. MIPI PLL Electrical Parameters

Table 5-14. MIPI PLL Electrical Parameters

Parameter	Value
Clock Output Range	182MHz ~1.5GHz
Reference Clock	24MHz
Max. Lock Time	500us
Max. Peak-to-Peak Supply Noise	200ps

5.8.6. DDR0/1 PLL Electrical Parameters

Table 5-15. DDR0/1 PLL Electrical Parameters

Parameter	Value	
Clock Output Range	192MHz ~1.6GHz	
Reference Clock	24MHz	
Max. Lock Time	2ms	
Max. Peak-to-Peak Supply Noise	192MHz ~800MHz	200ps
	800MHz ~1.3GHz	140ps
	1.3GHz ~1.6GHz	100ps

5.8.7. Video0/1 PLL Electrical Parameters

Table 5-16. Video0/1 PLL Electrical Parameters

Parameter	Value
Clock Output Range	192MHz ~600MHz
Reference Clock	24MHz
Max. Lock Time	500us
Max. Peak-to-Peak Supply Noise	200ps

5.8.8. VE PLL Electrical Parameters

Table 5-17. VE PLL Electrical Parameters

Parameter	Value
Clock Output Range	192MHz ~600MHz
Reference Clock	24MHz
Max. Lock Time	500us

Max. Peak-to-Peak Supply Noise	200ps
--------------------------------	-------

5.8.9. DE PLL Electrical Parameters

Table 5-18. DE PLL Electrical Parameters

Parameter	Value
Clock Output Range	192MHz ~600MHz
Reference Clock	24MHz
Max. Lock Time	500us
Max. Peak-to-Peak Supply Noise	200ps

5.8.10. SATA PLL Electrical Parameters

Table 5-19. SATA PLL Electrical Parameters

Parameter	Value
Clock Output Range	8MHz~300MHz
Reference Clock	24MHz
Max. Lock Time	2ms
Max. Peak-to-Peak Supply Noise	140ps

5.9. Oscillator Electrical Characteristics

A40i contains two external input clocks: X24MIN and X32KIN, two output clocks: X24MOUT and X32KOUT.

The 24MHz frequency is used to generate the main source clock for PLL and the main digital blocks, the clock is provided through X24MIN. Table 5-20 lists the 24MHz crystal specifications.

Table 5-20. 24MHz Crystal Characteristics

Symbol	Parameter	Min	Typ	Max	Unit
$1/(t_{CPMAIN})$	Crystal Oscillator Frequency Range	-	24.000	-	MHz
t_{ST}	Startup Time	-	-	-	ms
	Frequency Tolerance at 25 °C	-50	-	+50	ppm
	Oscillation Mode	Fundamental			-
	Maximum Change Over Temperature Range	-50	-	+50	ppm
P_{ON}	Drive Level	-	-	50	uW
C_L	Equivalent Load Capacitance	12	18	22	pF
R_S	Series Resistance(ESR)	-	25	-	Ω
	Duty Cycle	30	50	70	%
C_I	Motional Capacitance	-	-	-	pF
C_O	Shunt Capacitance	5	6.5	7.5	pF
R_{BIAS}	Internal Bias Resistor	0.5	0.6	0.7	M Ω

The 32768Hz frequency is used for low frequency operation. It supplies the wake-up domain for operation in lowest power mode. The clock is provided through X32KIN. Table 5-21 lists the 32768Hz crystal specifications.

Table 5-21. 32768Hz Crystal Characteristics

Symbol	Parameter	Min	Typ	Max	Unit
$1/(t_{CPMAIN})$	Crystal Oscillator Frequency Range	-	32768	-	Hz
t_{ST}	Startup Time	-	-	-	ms
	Frequency Tolerance at 25 °C	-20	-	+20	ppm
	Oscillation Mode	Fundamental			-
	Maximum Change Over Temperature Range	-20	-	+20	ppm
P_{ON}	Drive Level	-	-	1.0	uW
C_L	Equivalent Load Capacitance	-	12.5	-	pF
R_s	Series Resistance(ESR)	-	-	35	kΩ
	Duty Cycle	30	50	70	%
C_i	Motional Capacitance	-	-	-	F
C_o	Shunt Capacitance	-	1.1	-	pF

5.10. Maximum Current Consumption

If you have questions about power consumption parameters, contact Allwinner FAE.

5.11. External Memory Electrical Characteristics

5.11.1. SDRAM AC Electrical Characteristics

DDR3/DDR3L Parameters

Figure 5-2 shows the DDR3/DDR3L command and address timing diagram. The timing parameters for this diagram shows in Table 5-22.

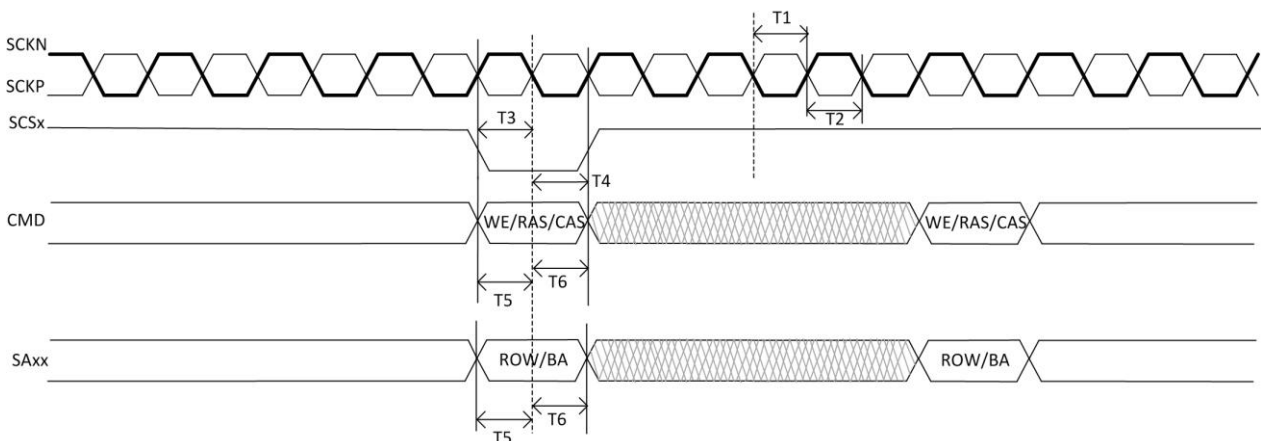

Figure 5-2. DDR3/DDR3L Command and Address Timing

Table 5-22. DDR3/DDR3L Timing Parameters

ID	Parameter	Symbol	Clock = 576 MHz			Unit
			Min	Suggest	Max	
T1	SCKP clock high-level width	t_{CH}	0.47	-	0.53	tck
T2	SCKP clock low-level width	t_{CL}	0.47	-	0.53	tck
T3	CS setup time	t_{IS}	170	295	-	ps
T4	CS hold time	t_{IH}	120	245	-	ps
T5	Command and Address setup time to Clock edge	t_{IS}	170	295	-	ps
T6	Command and Address hold time to Clock	t_{IH}	120	245	-	ps

edge					
------	--	--	--	--	--

T1 and T2 are in reference to Vref level.

T3,T4,T5, and T6 are in reference to Vih(ac) /Vil(ac) levels. (AC150/DC100).

Figure 5-3 shows the DDR3/DDR3L write timing diagram. The timing parameters for this diagram shows in Table 5-23.

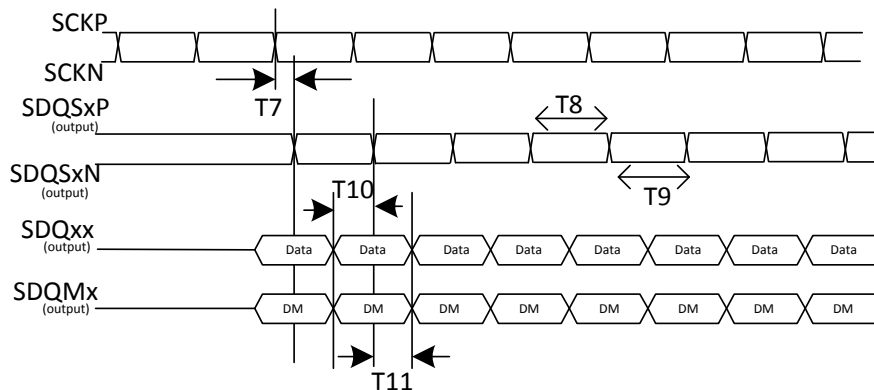

Figure 5-3. DDR3/DDR3L Write Cycle

Table 5-23. DDR3/DDR3L Write Cycle Parameters

ID	Parameter	Symbol	Clock = 576 MHz			Unit
			Min	Suggest	Max	
T7	SDQSxP/SDQSxN rising edge to SCKP/SCKN rising edge	t_{DQSS}	-0.27	-	0.27	t_{CK}
T8	SDQSxP high level width	t_{DQSH}	0.45	-	0.55	t_{CK}
T9	SDQSxP low level width	t_{DQSL}	0.45	-	0.55	t_{CK}
T10	Data setup time to SDQSxP/SDQSxN	t_{DS}	10	145	-	ps
T11	Data hold time to SDQSxP/SDQSxN	t_{DH}	45	180	-	ps

To receive the reported setup and hold values, write calibration should be performed in order to locate the SDQSx in the middle of SDQxx window.

T7,T8, and T9 are in reference to Vref level.

T10 and T11 are in reference to Vih(ac) /Vil(ac) levels. (AC150/DC100).

Figure 5-4 shows the DDR3/DDR3L read timing diagram. The timing parameters for this diagram shows in Table 5-24.

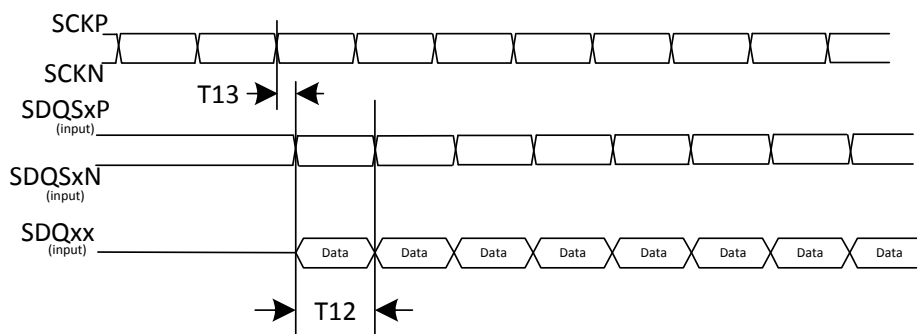

Figure 5-4. DDR3/DDR3L Read Cycle

Table 5-24. DDR3/DDR3L Read Cycle Parameters

ID	Parameter	Symbol	Clock = 576 MHz		Unit
			Min	Max	
T12	Read Data valid width	t_{Data}	200	-	ps
T13	SDQSxP/SDQSxN rising edge to SCKP/SCKN rising edge	t_{DQsck}	-225	225	ps

To receive the reported setup and hold values, write calibration should be performed in order to locate the SDQSx in the middle of SDQxx window.

T12 and T13 are in reference to Vref level.

LPDDR3 Parameters

Figure 5-5 shows the LPDDR3 command and address timing diagram. The timing parameters for this diagram shows in Table 5-25.

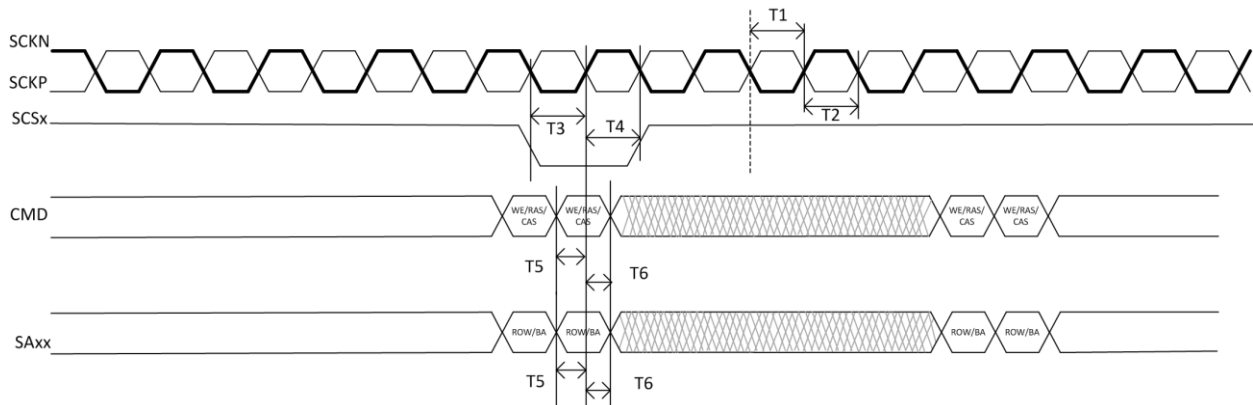

Figure 5-5. LPDDR3 Command and Address Timing Diagram

Table 5-25. LPDDR3 Command and Address Timing Parameters

ID	Parameter	Symbol	Clock = 480 MHz			Unit
			Min	Suggest	Max	
T1	Clock high pulse width	t_{CH}	0.45	-	0.55	t_{CK}
T2	Clock low pulse width	t_{CL}	0.45	-	0.55	t_{CK}
T3	SCSx input setup time	t_{iSCS}	195	347.5	-	ps
T4	SCSx input hold time	t_{IHCS}	220	372.5	-	ps
T5	Address and control input setup time	t_{IAS}	75	152.5	-	ps
T6	Address and control input hold time	t_{IAH}	100	177.5	-	ps

T1 and T2 are in reference to Vref level.

T3,T4,T5, and T6 are in reference to Vih(ac) /Vil(ac) levels. (AC150/DC100).

Figure 5-6 shows the LPDDR3 write timing diagram. The timing parameters for this diagram shows in Table 5-26.

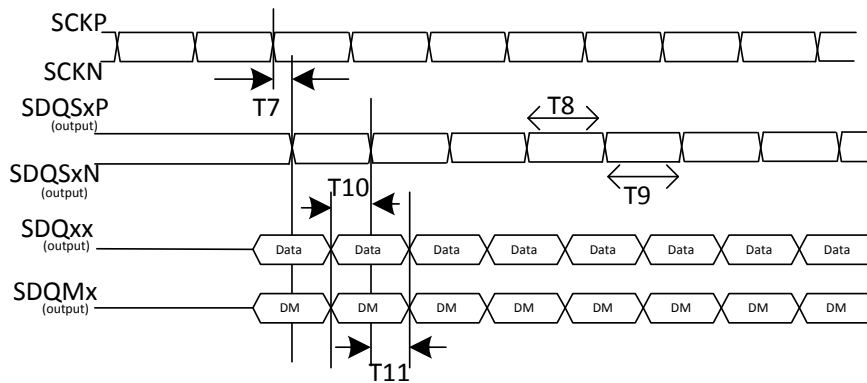

Figure 5-6. LPDDR3 Write Cycle

Table 5-26. LPDDR3 Write Cycle Parameters

ID	Parameter	Symbol	Clock = 480 MHz			Unit
			Min	Suggest	Max	
T7	SDQxP/SDQxN rising edge to SCKP/SCKN rising edge	t_{DQSS}	0.75	-	1.25	t_{CK}
T8	SDQx input high-level width	t_{DQSH}	0.4	-	-	t_{CK}
T9	SDQx input low-level width	t_{DQSL}	0.4	-	-	t_{CK}
T10	SDQxx and SDQMx input setup time	t_{DS}	75	152.5	-	ps
T11	SDQxx and SDQMx input hold time	t_{DH}	100	177.5	-	ps

To receive the reported setup and hold values, write calibration should be performed in order to locate the SDQx in the middle of SDQxx window.

T7,T8, and T9 are in reference to Vref level.

T10 and T11 are in reference to $V_{ih}(ac)$ / $V_{il}(ac)$ levels. (AC150/DC100).

Figure 5-7 shows the LPDDR3 read timing diagram. The timing parameters for this diagram shows in Table 5-27.

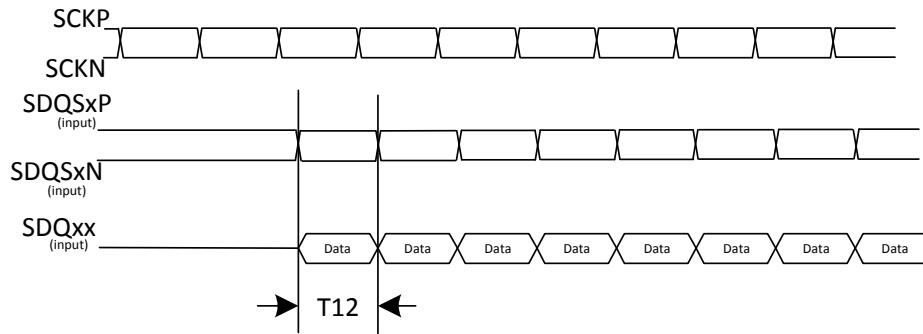

Figure 5-7. LPDDR3 Read Cycle

Table 5-27. LPDDR3 Read Cycle Parameters

ID	Parameter	Symbol	Clock = 480 MHz		Unit
			Min	Max	
T12	Read Data valid width	t_{DATA}	200	-	ps

To receive the reported setup and hold values, write calibration should be performed in order to locate the SDQSx in the middle of SDQxx window.

T12 is in reference to V_{ref} level.

LPDDR2 Parameters

Figure 5-8 shows the LPDDR2 command and address timing diagram. The timing parameters for this diagram shows in Table 5-28.

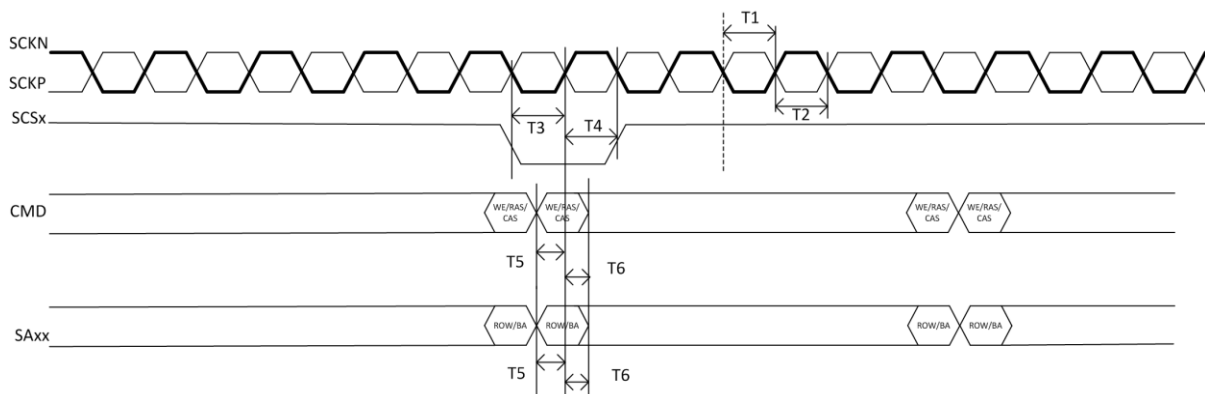

Figure 5-8. LPDDR2 Command and Address Timing Diagram

Table 5-28. LPDDR2 Command and Address Timing Parameters

ID	Parameter	Symbol	Clock = 432 MHz		Unit
			Min	Max	
T1	Clock high pulse width	t_{CH}	0.45	0.55	t_{CK}
T2	Clock low pulse width	t_{CL}	0.45	0.55	t_{CK}
T3	SCSx input setup time	t_{IS}	220	-	ps
T4	SCSx input hold time	t_{IH}	220	-	ps
T5	Address and control input setup time	t_{IS}	220	-	ps
T6	Address and control input hold time	t_{IH}	220	-	ps

All measurements are in reference to V_{ref} level.

Figure 5-9 shows the LPDDR2 write timing diagram. The timing parameters for this diagram shows in Table 5-29.

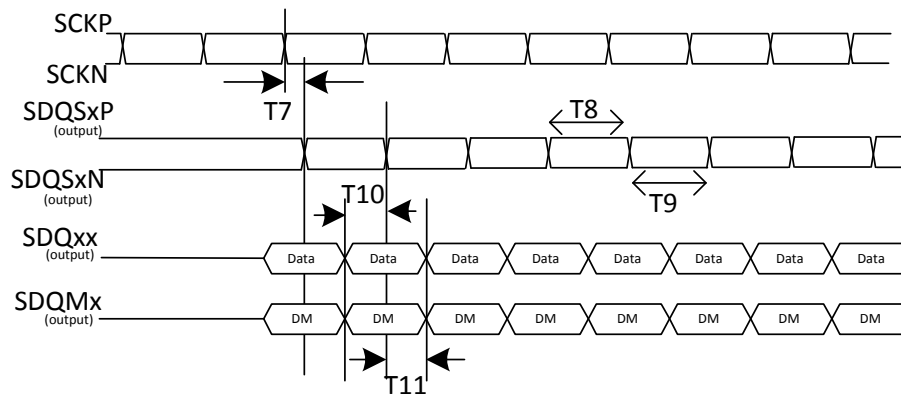

Figure 5-9. LPDDR2 Write Cycle

Table 5-29. LPDDR2 Write Cycle Parameters

ID	Parameter	Symbol	Clock = 432 MHz		Unit
			Min	Max	
T7	SDQSxP/SDQSxN rising edge to SCKP/SCKN rising edge	t_{DQSS}	0.75	1.25	t_{CK}
T8	SDQSx input high-level width	t_{DQSH}	0.4	-	t_{CK}
T9	SDQSx input low-level width	t_{DQSL}	0.4	-	t_{CK}
T10	SDQxx and SDQMx input setup time	t_{DS}	210	-	ps
T11	SDQxx and SDQMx input hold time	t_{DH}	210	-	ps

To receive the reported setup and hold values, write calibration should be performed in order to locate the SDQSx in the middle of SDQxx window.

All measurements are in reference to Vref level.

Figure 5-10 shows the LPDDR2 read timing diagram. The timing parameters for this diagram shows in Table 5-30.

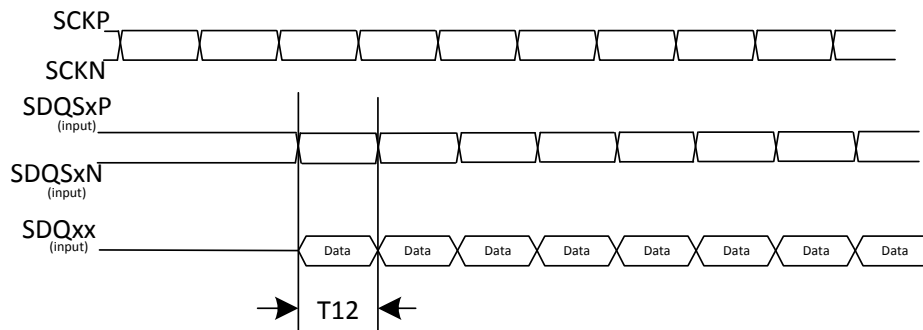

Figure 5-10. LPDDR2 Read Cycle

Table 5-30. LPDDR2 Read Cycle Parameters

ID	Parameter	Symbol	Clock = 432 MHz		Unit
			Min	Max	
T12	Read Data valid width	t_{DATA}	300	-	ps

To receive the reported setup and hold values, write calibration should be performed in order to locate the SDQSx in the middle of SDQxx window.

T12 is in reference to Vref level.

5.11.2. Nand AC Electrical Characteristics

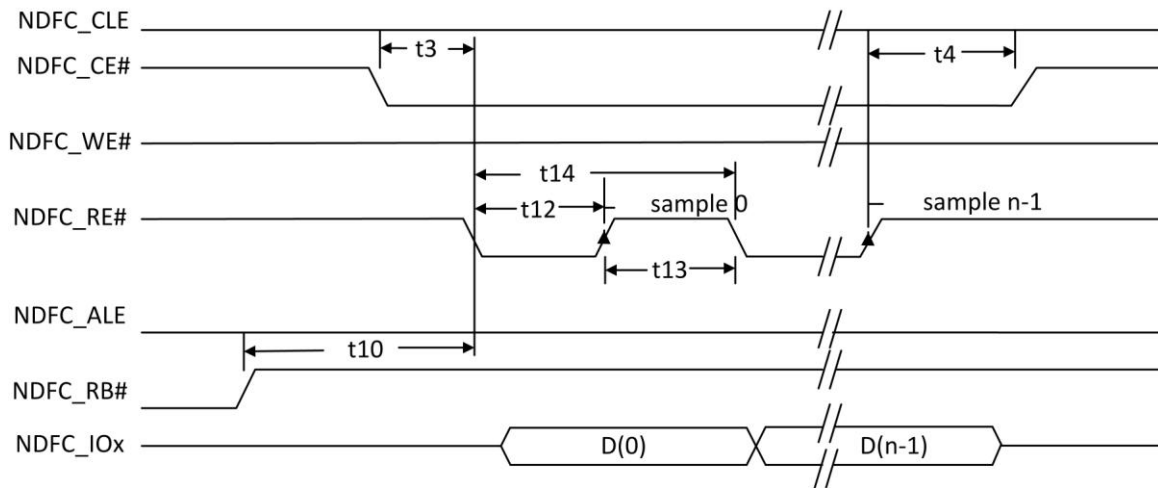

Figure 5-11. Conventional Serial Access Cycle Timing (SAM0)

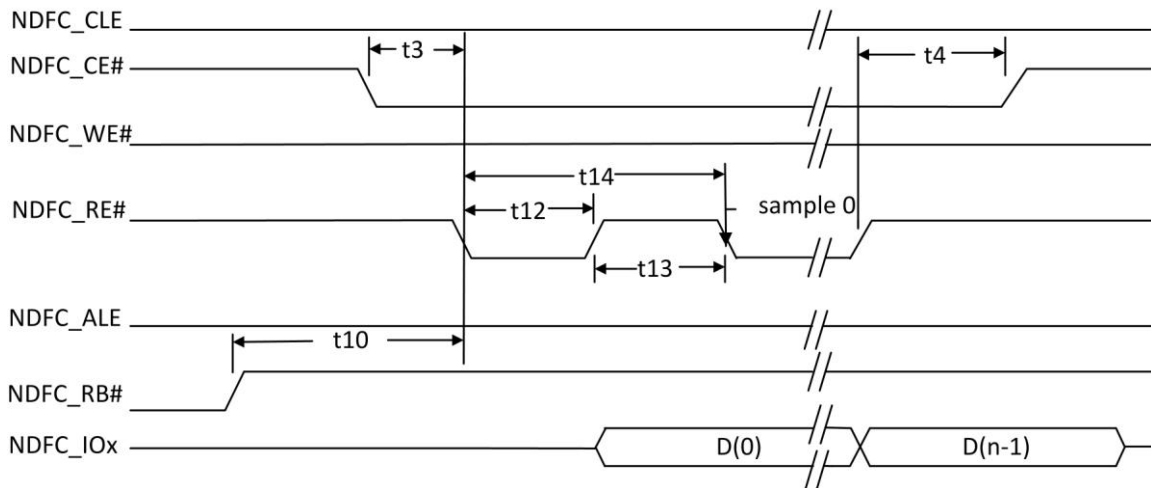

Figure 5-12. EDO Type Serial Access after Read Cycle Timing (SAM1)

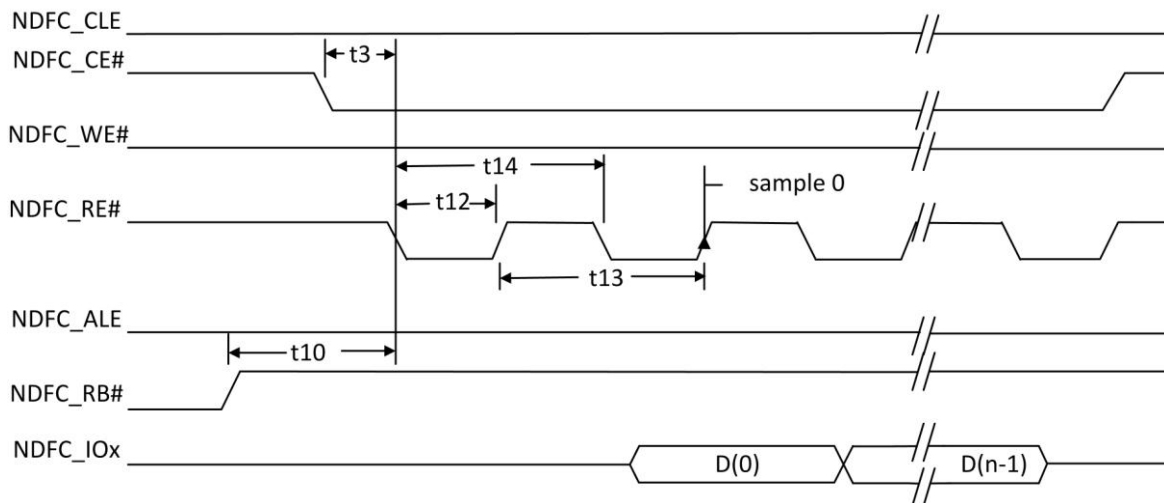

Figure 5-13. Extending EDO Type Serial Access Mode Timing (SAM2)

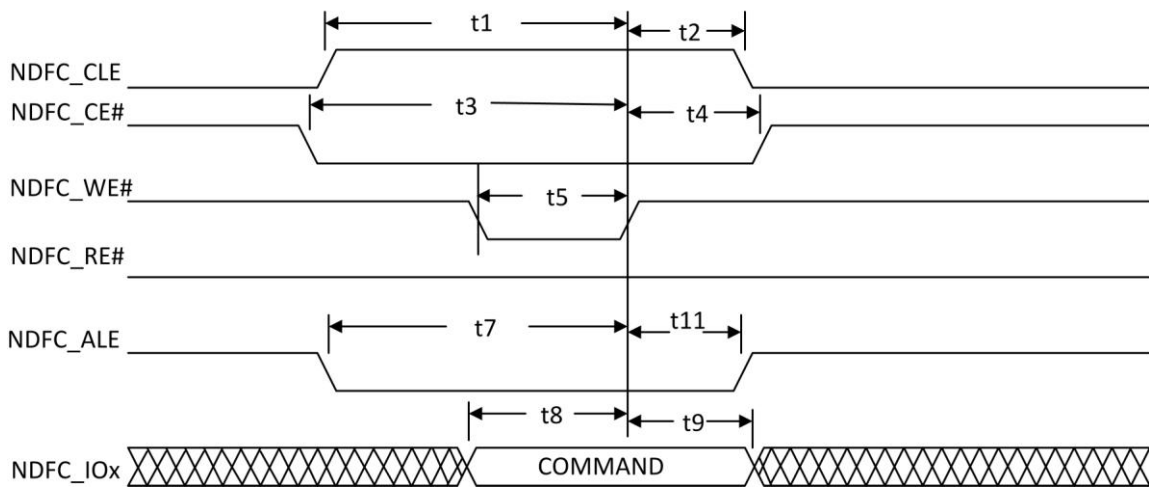

Figure 5-14. Command Latch Cycle Timing

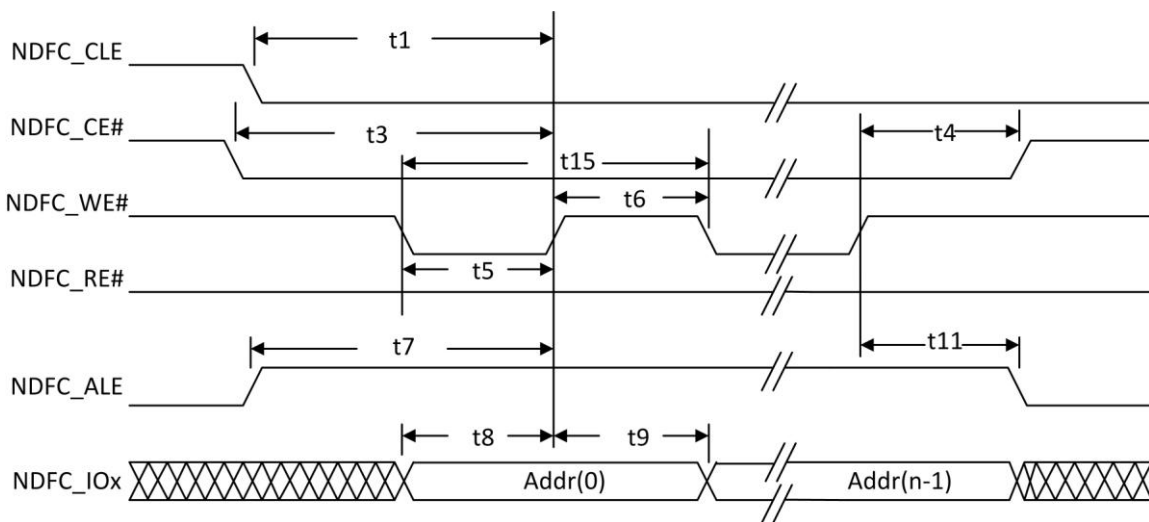

Figure 5-15. Address Latch Cycle Timing

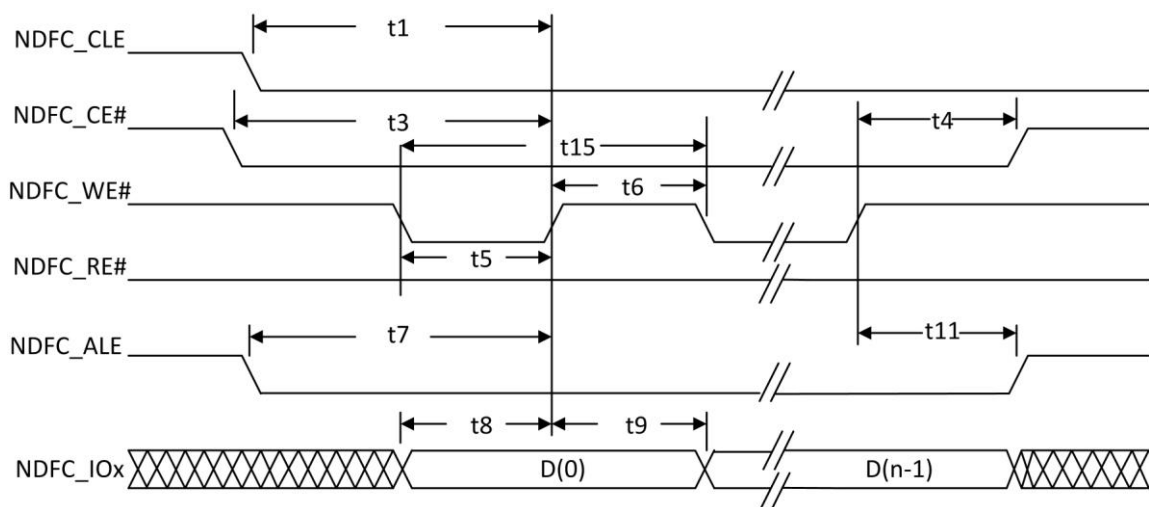
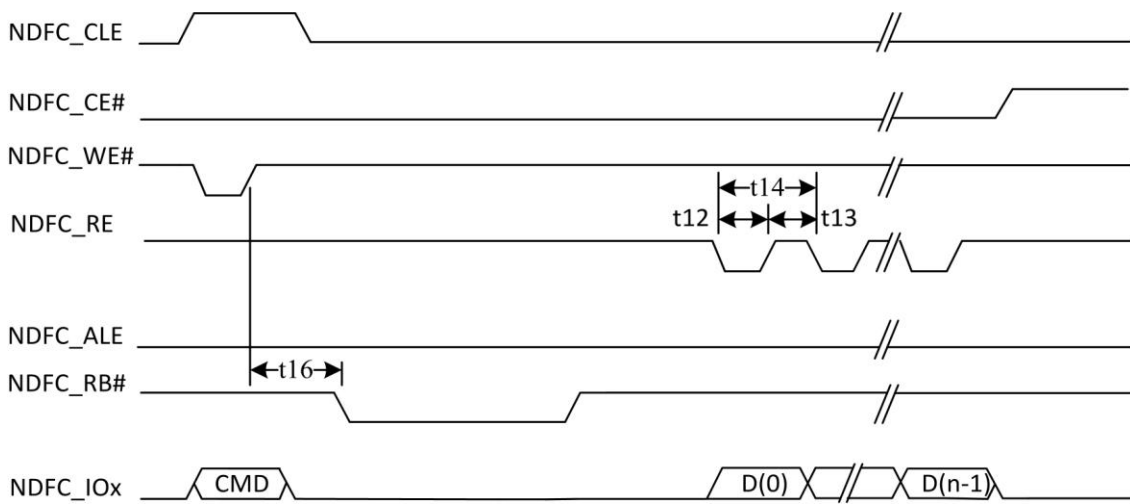
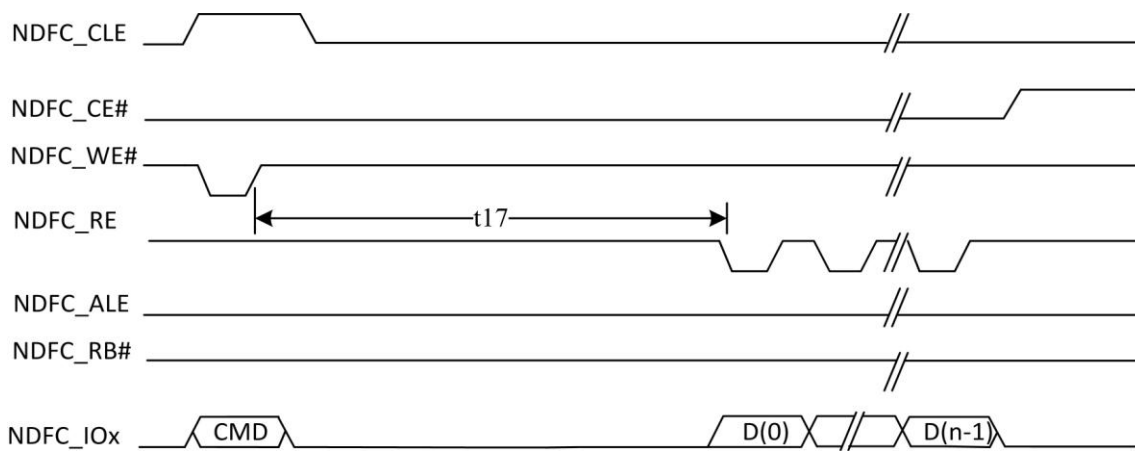
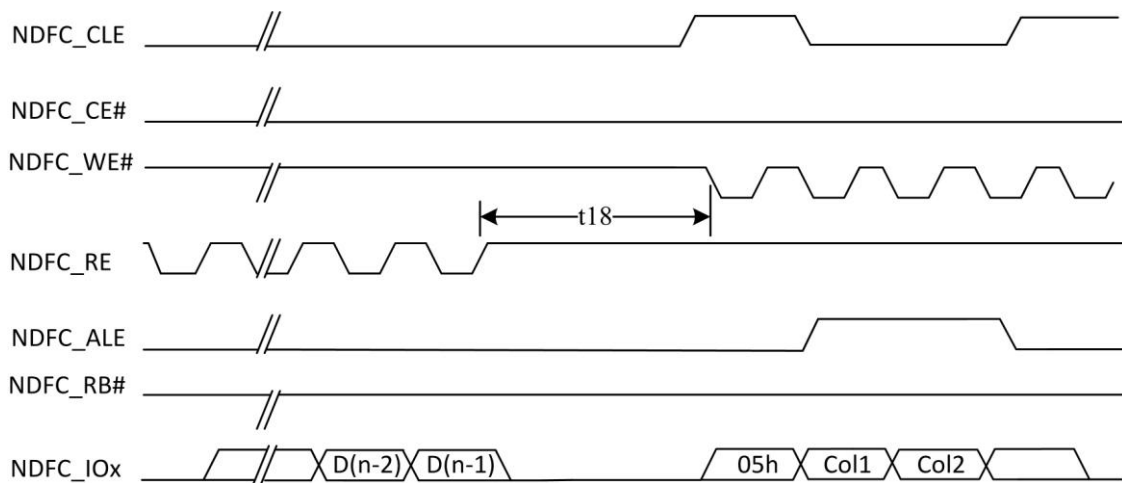

Figure 5-16. Write Data to Flash Cycle Timing

Figure 5-17. Waiting R/B# Ready Timing

Figure 5-18. WE# High to RE# Low Timing

Figure 5-19. RE# High to WE# Low Timing

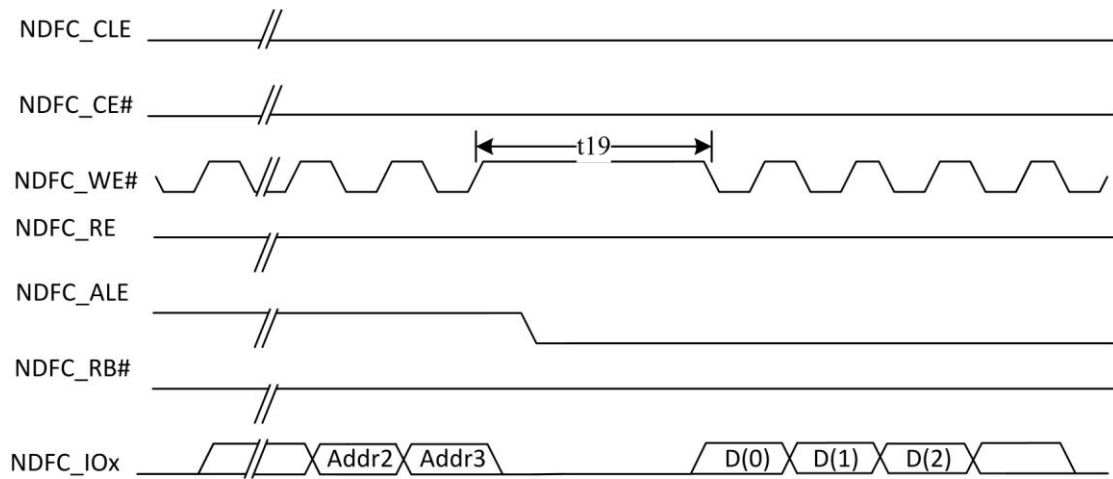

Figure 5-20. Address to Data Loading Timing

Table 5-31. NAND Timing Constants

Parameter	Symbol	Timing	Unit
NDFC_CLE setup time	t1	2T	ns
NDFC_CLE hold time	t2	2T ⁽¹⁾	ns
NDFC_CE setup time	t3	2T	ns
NDFC_CE hold time	t4	2T	ns
NDFC_WE# pulse width	t5	T	ns
NDFC_WE# hold time	t6	T	ns
NDFC_ALE setup time	t7	2T	ns
Data setup time	t8	T	ns
Data hold time	t9	T	ns
Ready to NDFC_RE# low	t10	3T	ns
NDFC_ALE hold time	t11	2T	ns
NDFC_RE# pulse width	t12	T	ns
NDFC_RE# hold time	t13	T	ns
Read cycle time	t14	2T	ns
Write cycle time	t15	2T	ns
NDFC_WE# high to R/B# busy	t16	T_WB ⁽²⁾	ns
NDFC_WE# high to NDFC_RE# low	t17	T_WHR ⁽³⁾	ns
NDFC_RE# high to NDFC_WE# low	t18	T_RHW ⁽⁴⁾	ns
Address to Data Loading time	t19	T_ADL ⁽⁵⁾	ns

NOTE (1):T is the cycle of clock.

NOTE (2),(3),(4),(5):This values is configurable in Nand Flash controller. The value of T_WB could be 28T/44T/60T/76T, the value of T_WHR could be 0T/12T/28T/44T, the value of T_RHW could be 8T/24T/40T/56T, the value of T_ADL could be 0T/12T/28T/44T.

5.11.3. SMHC AC Electrical Characteristics

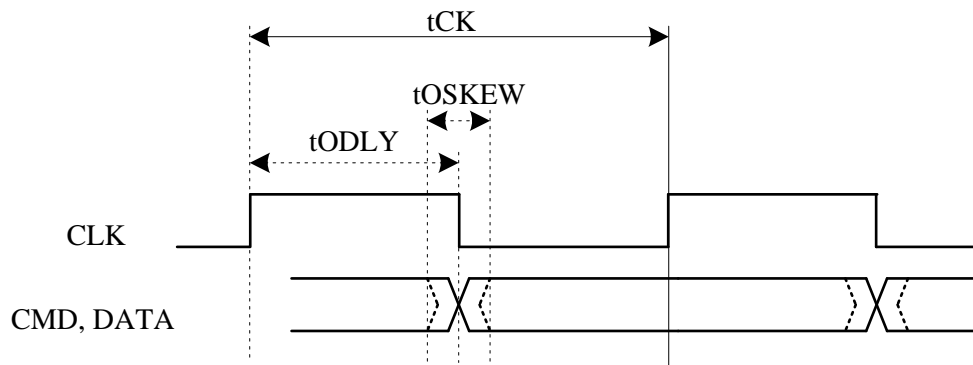

Figure 5-21. SMHC in SDR Mode Output Timing

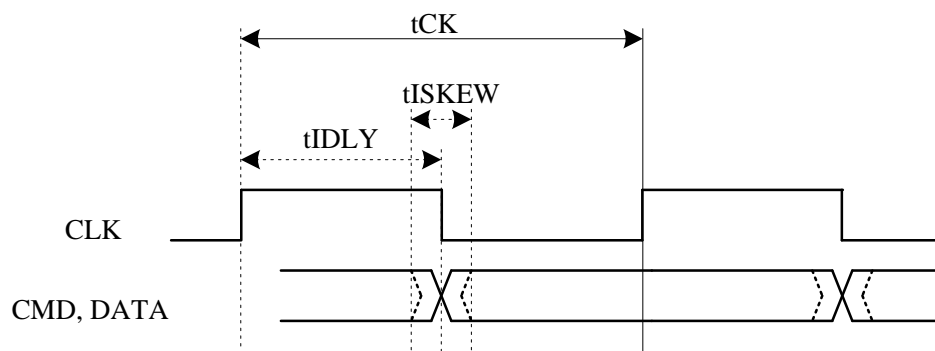

Figure 5-22. SMHC in SDR Mode Input Timing

Table 5-32. SMHC Timing Constants

Parameter	Symbol	Min	Type	Max	Unit
Clock frequency	tCK	0	50	50	MHz
Duty Cycle	DC	45	50	55	%
CMD, Data output delay time	tODLY	-	-	12	ns
Data output delay skew time	tOSKEW	-	-	0.5	ns
Data input delay in SDR mode. It includes Clock's PCB delay time, Data's PCB delay time and device's data output delay.	tIDLY	-	-	21	ns
Data input skew time in SDR mode	tISKEW	-	-	0.8	ns

Note (1): Output CMD, DATA is referenced to CLK.

5.12. External Peripherals Electrical Characteristics

5.12.1. LCD AC Electrical Characteristics

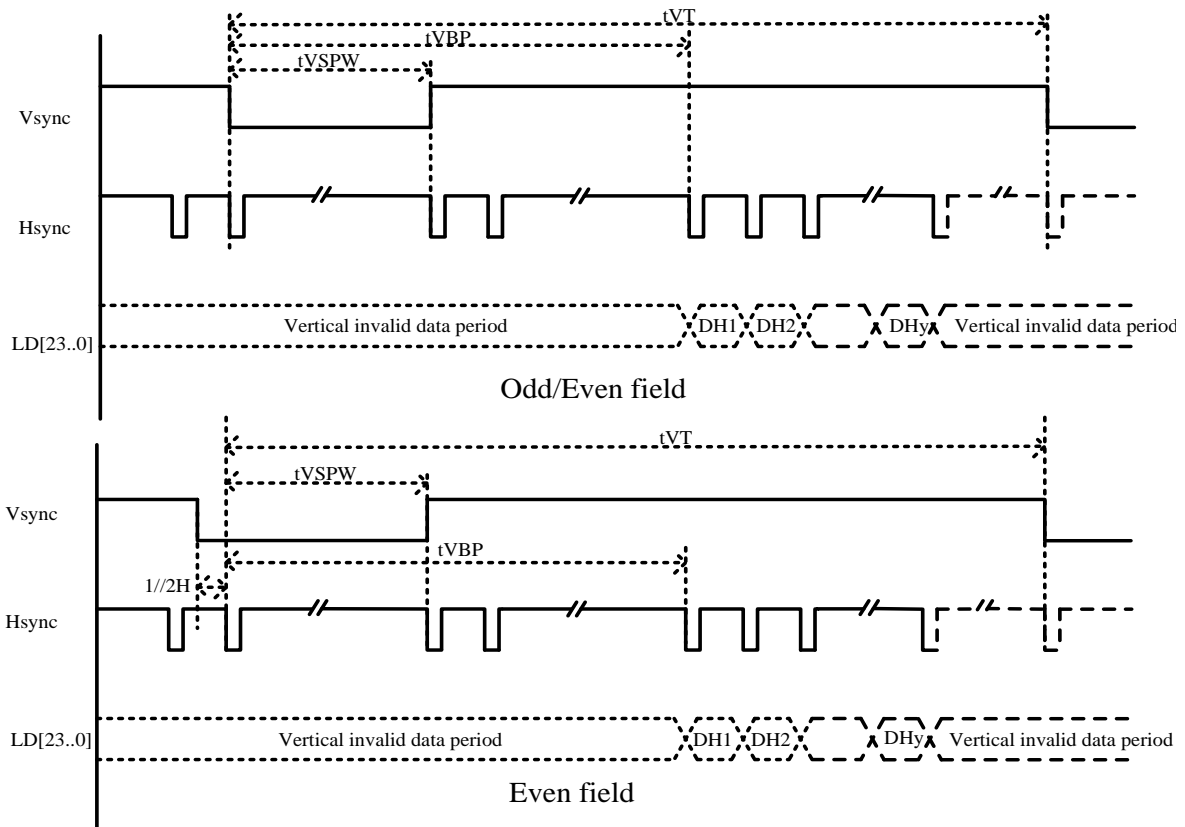

Figure 5-23. HV_IF Interface Vertical Timing

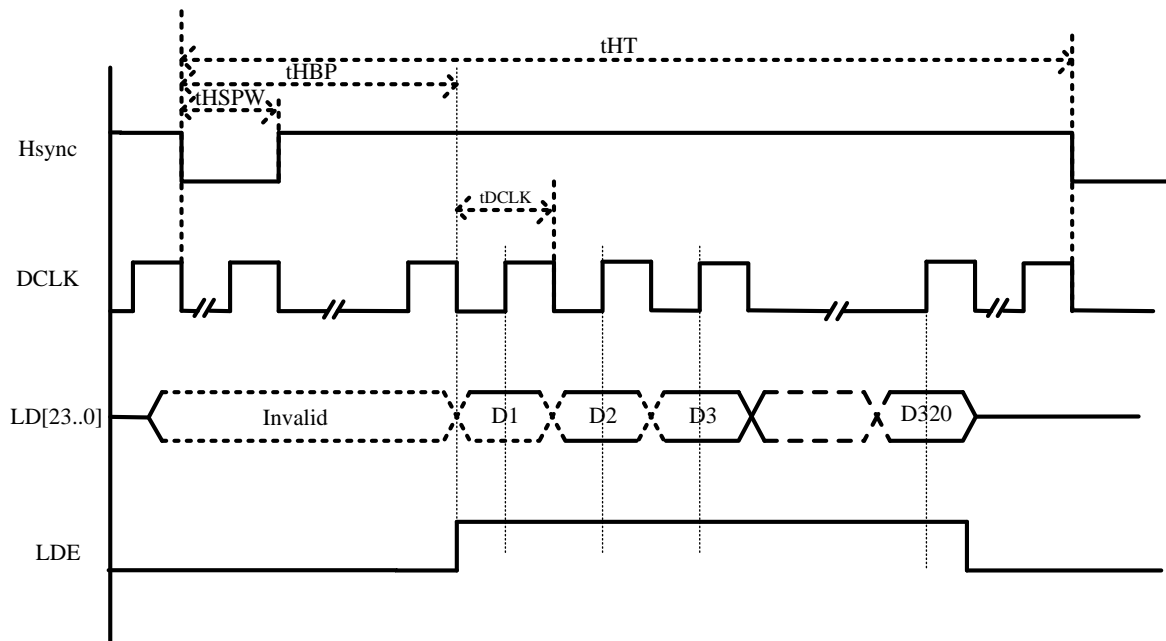

Figure 5-24. HV_IF Interface Parallel Mode Horizontal Timing

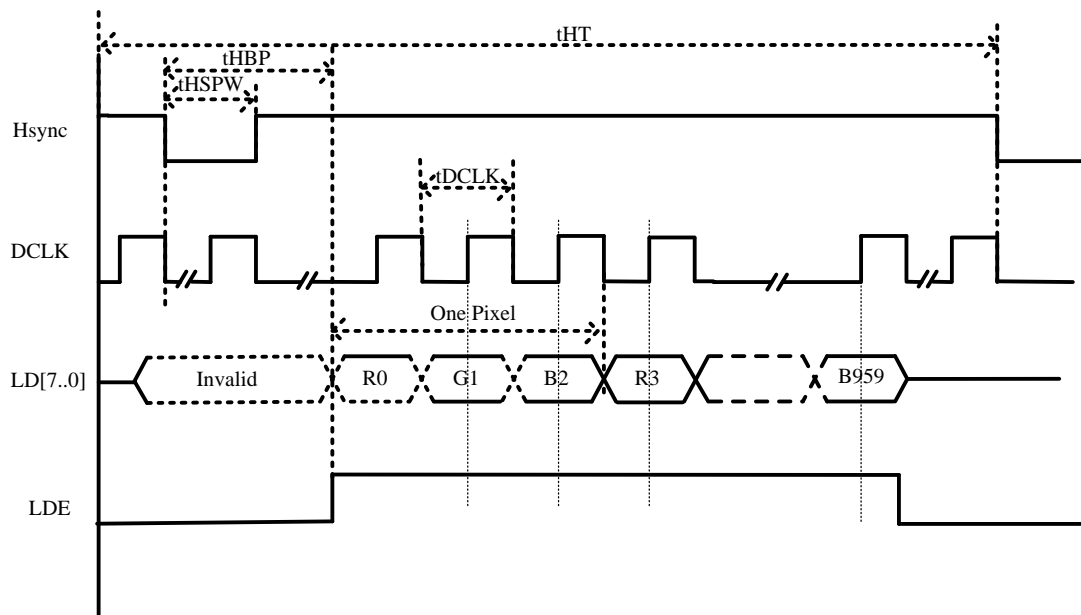

Figure 5-25. HV_IF Interface Serial Mode Horizontal Timing

Table 5-33. LCD HV_IF Interface Timing Constants

Parameter	Symbol	Min	Typ	Max	Unit
DCLK cycle time	tDCLK	5	-	-	ns
HSYNC period time	tHT	-	HT+1	-	tDCLK
HSYNC width	tHSPW	-	HSPW+1	-	tDCLK
HSYNC back porch	tHBP	-	HBP+1	-	tDCLK
VSYNC period time	tVT	-	VT/2	-	tHT
VSYNC width	tVSPW	-	VSPW+1	-	tHT
VSYNC back porch	tVBP	-	VBP+1	-	tHT

- (1). Vsync: Vertical sync, indicates one new frame
- (2). Hsync: Horizontal sync, indicate one new scan line
- (3). DCLK: Dot clock, pixel data are sync by this clock
- (4). LDE: LCD data enable
- (5). LD[23..0]: 24Bit RGB/YUV output from input FIFO for panel

5.12.2. CSI AC Electrical Characteristics

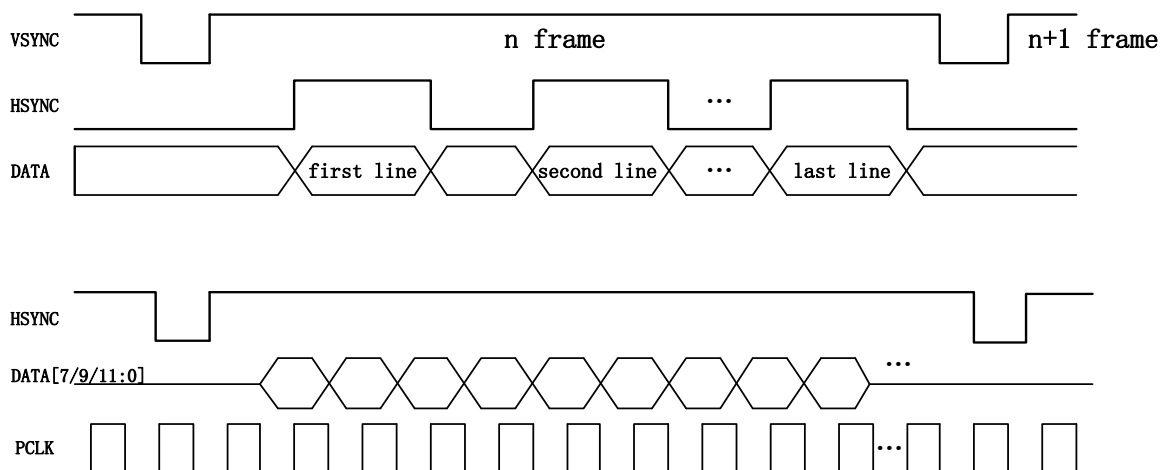

Figure 5-26. 8/10/12-bit CMOS Sensor Interface Timing
(clock rising edge sample. vsync valid = positive, hsync valid = positive)

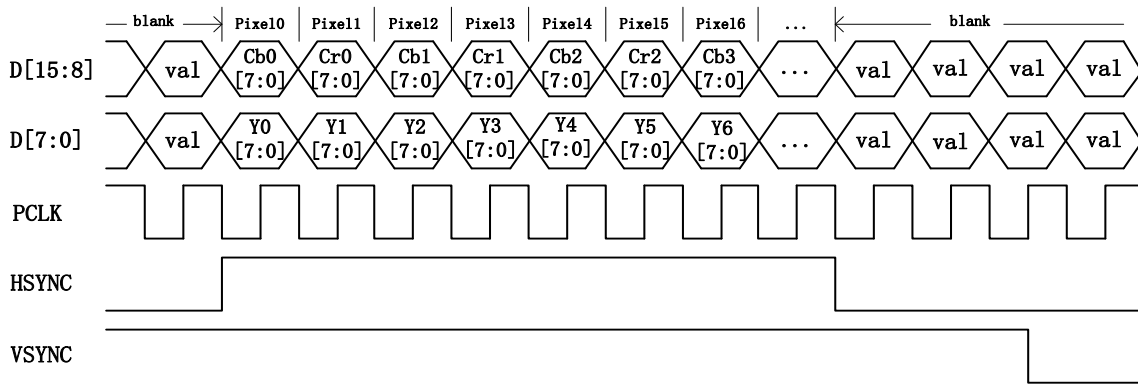

Figure 5-27. 16-bit YCbCr4:2:2 with Separate Sync Timing
(clock rising edge sample. vsync valid = positive, hsync valid = positive)

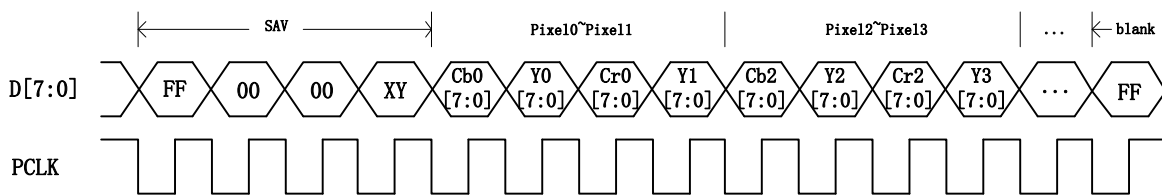

Figure 5-28. 8-bit YCbCr4:2:2 with Embedded Syncs(BT656) Timing

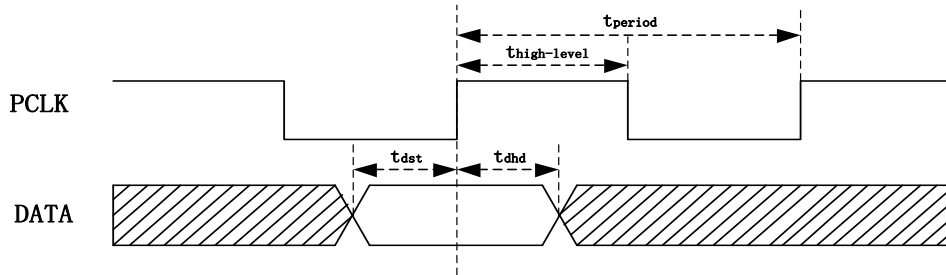

Figure 5-29. Data Sample Timing

Table 5-34. CSI Interface Timing Constants

Parameter	Symbol	Min	Typ	Max	Unit
Pclk Period	t_{period}	5.95	-	-	ns
Pclk Frequency	$1/t_{period}$	-	-	168	MHz
Pclk Duty	$t_{high-level}/t_{period}$	40	50	60	%
Data input Setup time	t_{dst}	0.6	-	-	ns
Data input Hold time	t_{dhd}	0.6	-	-	ns

5.12.3. EMAC AC Electrical Characteristics

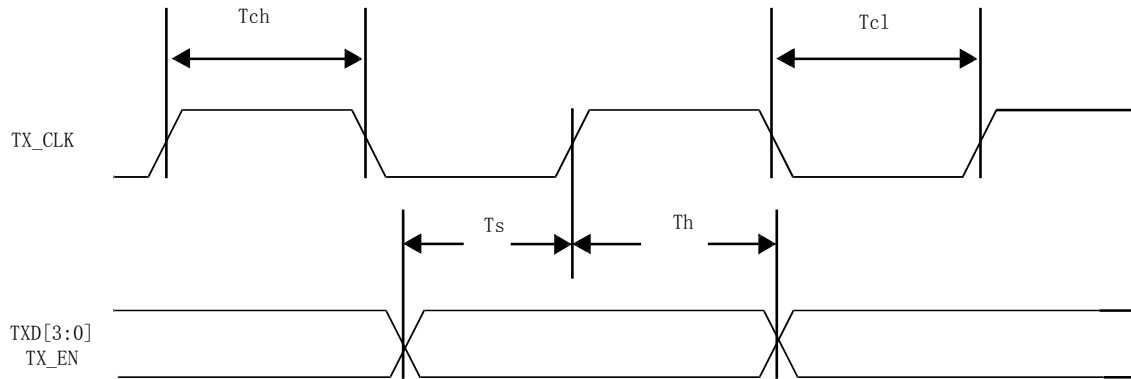

Figure 5-30. EMAC MII Interface Transmit Timing

Table 5-35. 100Mb/s MII Transmit Timing Constants

Parameter	Symbol	Min	Type	Max	Unit
Transmit Clock High Time,100M mode	Tch	-	20	-	ns
Transmit Clock Low Time,100M mode	Tcl	-	20	-	ns
TXEN/TXD setup time to TX_CLK	Ts	10	-	-	ns
TXEN/TXD hold time to TX_CLK	Th	0	-	-	ns

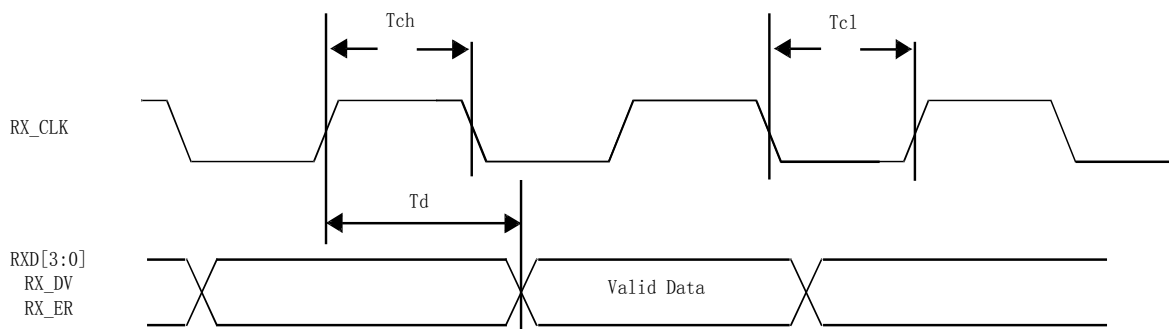

Figure 5-31. EMAC MII Interface Receive Timing

Table 5-36. 100Mb/s MII Receive Timing Constants

Parameter	Symbol	Min	Type	Max	Unit
Receive Clock High Time,100M mode	Tch	-	20	-	ns
Receive Clock Low Time,100M mode	Tcl	-	20	-	ns
RX_CLK to RXD[3:0]/RX_DV/RX_ER Delay	Td	10	-	30	ns

5.12.4. PS2 AC Electrical Characteristics

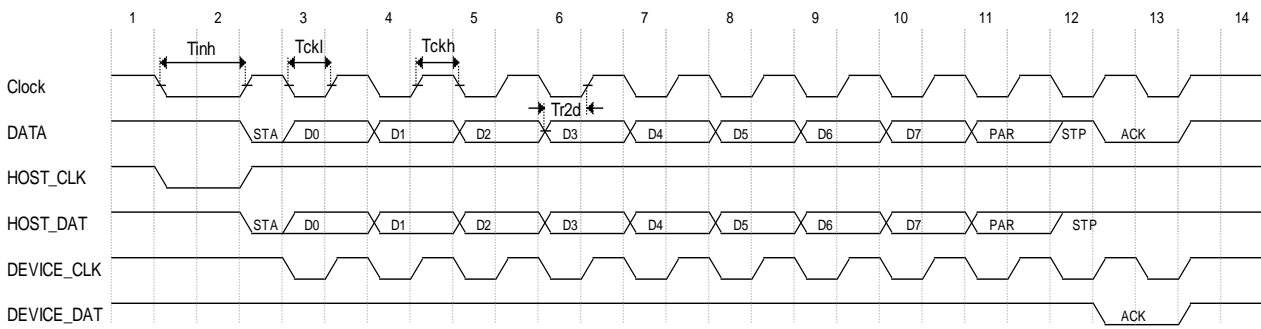

Figure 5-32. PS2 Timing for Master Transmit Data and Device Receive Data

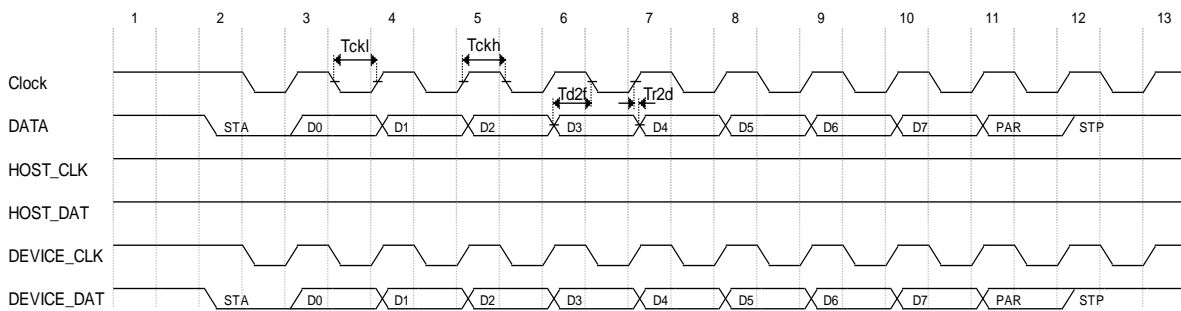

Figure 5-33. PS2 Timing for Device Transmit Data and Master Receive Data

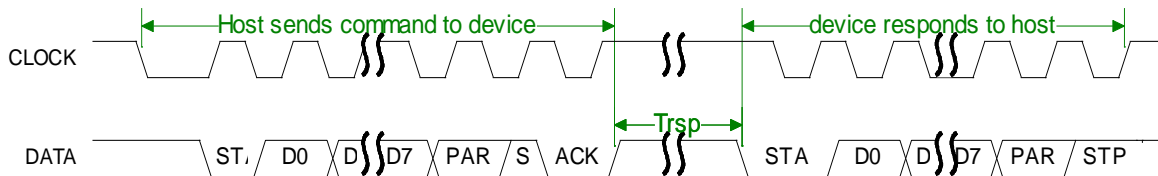

Figure 5-34. PS2 Timing for Master Sending Command then Device Sending Response

Table 5-37. PS2 Timing Constants

Parameter	Symbol	Min	Type	Max	Unit
Clock Low time	Tckl	30	40	50	us
Clock High time	Tckh	30	40	50	us
Time for Host inhibit clock for send data request	Tinh	100	-	-	us
Data change to clock falling edge time during device to host transfer	Td2f	5	-	Tckh-5	us
Clock rising edge to data change time during device to host transfer	Tr2d	5	-	Tckh-5	us
Data change to clock rising edge time during host to device transfer	Td2r	5	-	Tckl-5	us
Clock falling edge to data change time during host to device transfer	Tf2d	5	-	Tckl-5	us
Host pull low Clock to Device drive Clock	Tc2c	-	-	15	ms
Time for packet to send	Tdata	-	-	2	ms
Time for device responding to the host command	Trsp	-	-	20	ms

5.12.5. CIR AC Electrical Characteristics

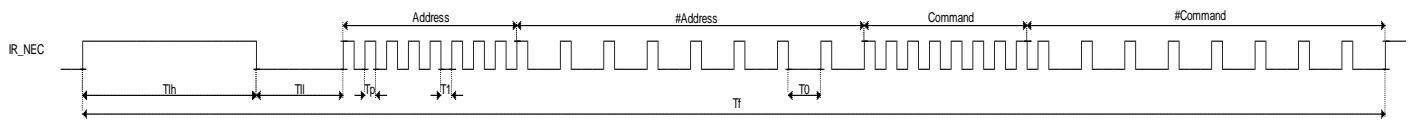

Figure 5-35. CIR-RX Timing

Table 5-38. CIR-RX Timing Constants

Parameter	Symbol	Min	Type	Max	Unit
Frame Period	Tf	-	67.5	-	ms
Lead Code High Time	Tlh	-	9	-	ms
Lead Code Low Time	Tll	-	4.5	-	ms
Pulse Time	Tp	-	560	-	us
Logical 1 Low Time	T1	-	1680	-	us
Logical 0 Low Time	T0	-	560	-	us

5.12.6. SPI AC Electrical Characteristics

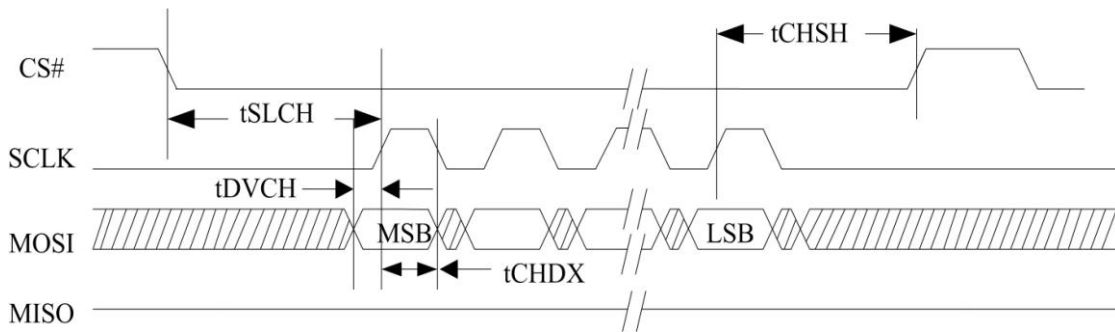

Figure 5-36. SPI MOSI Timing

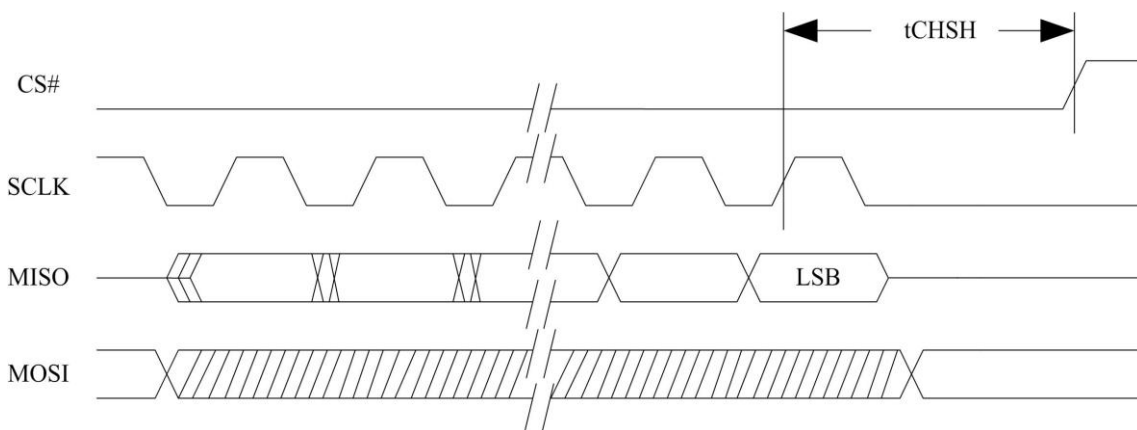

Figure 5-37. SPI MISO Timing

Table 5-39. SPI Timing Constants

Parameter	Symbol	Min	Typ	Max	Unit
CS# Active Setup Time	tSLCH	-	2T	-	ns
CS# Active Hold Time	tCHSH	-	2T ⁽¹⁾	-	ns

Data In Setup Time	tDVCH	-	T/2-3	-	ns
Data In Hold Time	tCHDX	-	T/2-3	-	ns
Note (1): T is the cycle of clock.					

5.12.7. UART AC Electrical Characteristics

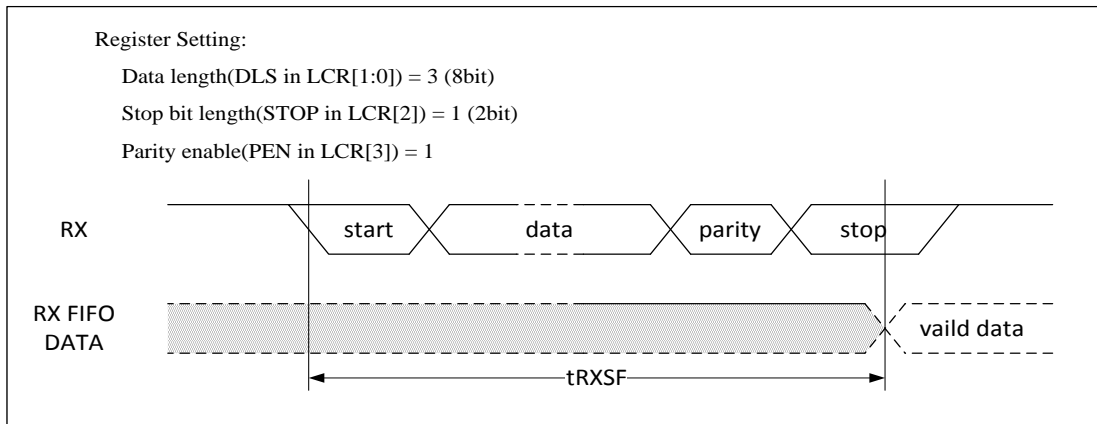

Figure 5-38. UART RX Timing

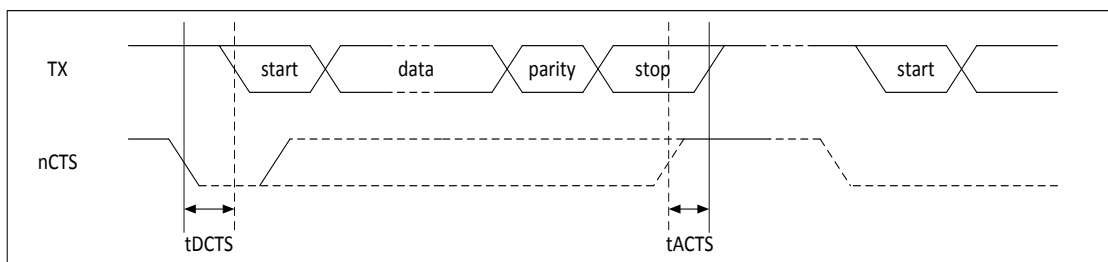

Figure 5-39. UART nCTS Timing

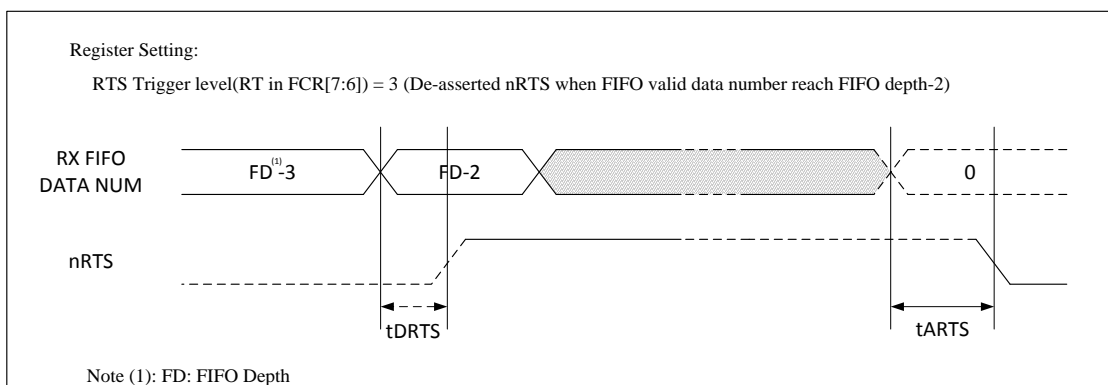

Figure 5-40. UART nRTS Timing

Table 5-40. UART Timing Constants

Parameter	Symbol	Min	Typ	Max	Unit
RX start to RX FIFO	tRXSF	$10.5 \times BRP^{(1)}$	-	$11 \times BRP^{(1)}$	ns
Delay time of de-asserted nCTS to TX start	tDCTS	-	-	$BRP^{(1)}$	ns
Step time of asserted nCTS to stop next transmission	tACTS	$BRP^{(1)}/4$	-	-	ns

Delay time of de-asserted nRTS	tDRTS	-	-	BRP ⁽¹⁾	ns
Delay time of asserted nRTS	tARTS	-	-	BRP ⁽¹⁾	ns
Note (1): BRP(Baud-Rate Period).					

5.12.8. TWI AC Electrical Characteristics

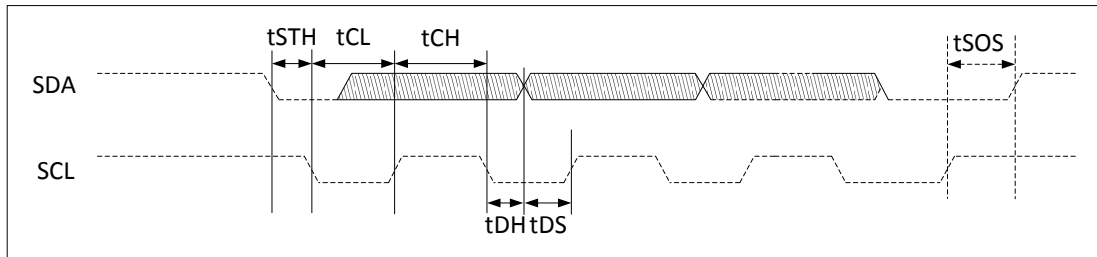

Figure 5-41. TWI Timing

Table 5-41. TWI Timing Constants

Parameter	Symbol	Min	Typ	Max	Unit
High period of SCL	tCH	0.96	-	-	μs
Low period of SCL	tCL	1.5	-	-	μs
SCL hold time for START condition	tSTH	1.5	-	-	μs
SCL step time for STOP condition	tSOS	1.6	-	-	μs
SDA hold time	tDH	0.82	-	-	μs
SDA step time	tDS	0.72	-	-	μs

5.12.9. TSC AC Electrical Characteristics

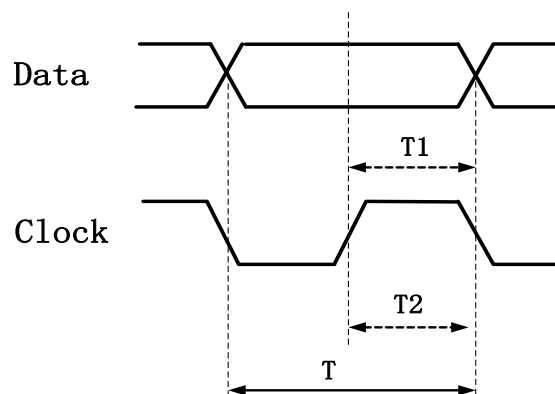

Figure 5-42. TSC Data and Clock Timing

Table 5-42. TSC Timing Constants

Parameter	Symbol	Min	Type	Max	Unit
Data hold time	T1	$T/2 - T/10$	$T^{(1)}/2$	$T/2 + T/10$	us
Clock pulse width	T2	$T/2 - T/10$	$T/2$	$T/2 + T/10$	us
Note (1): T is the cycle of clock.					

5.12.10. AC97 AC Electrical Characteristics

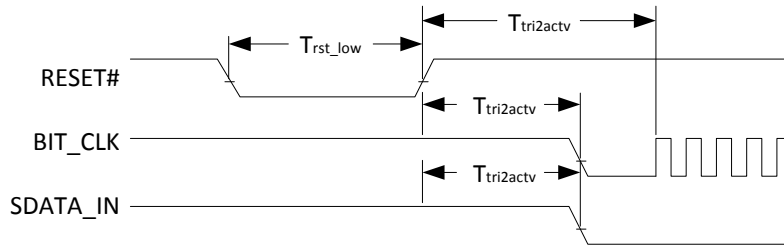

Figure 5-43. AC97 Cold Reset Timing

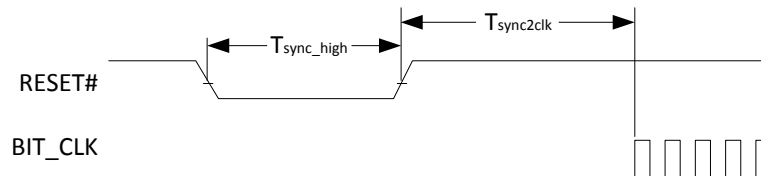

Figure 5-44. AC97 Warm Reset Timing

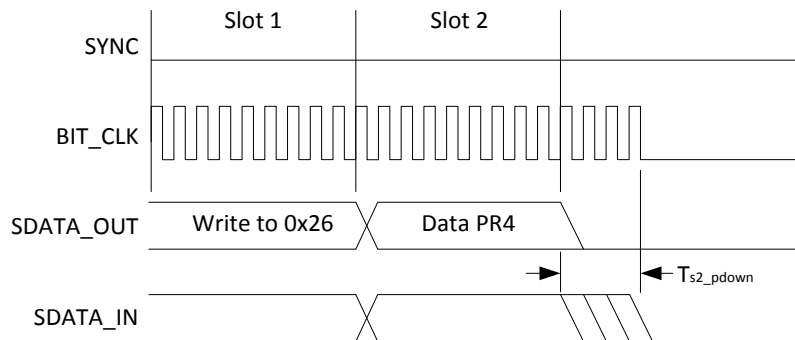

Figure 5-45. AC-link Low Power Mode Timing

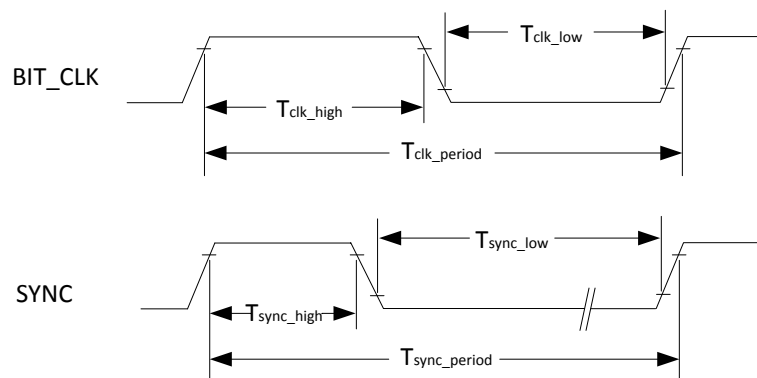

Figure 5-46. BIT_CLK and SYNC Timing

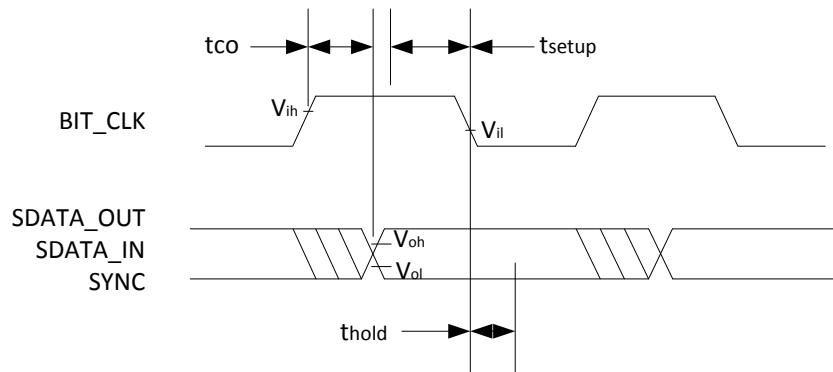

Figure 5-47. AC-link Data Transmission Output and Input Timing

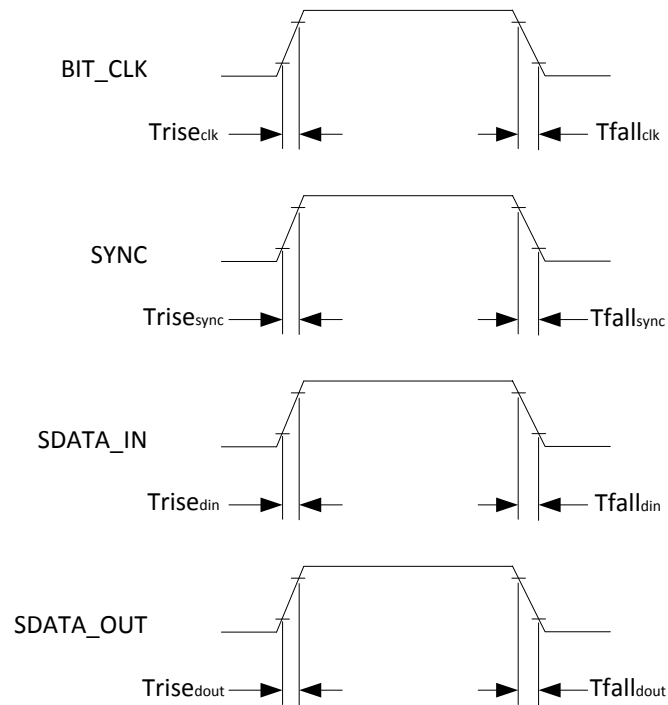

Figure 5-48. Signal Rise and Fall Timing

Table 5-43. AC97 Timing Constants

Parameter	Symbol	Min	Type	Max	Unit
RESET# active low pulse width	T_{rst_low}	1.0	-	-	us
RESET# inactive to SDATA_IN Or BIT_CLK active delay	$T_{tri2actv}$	-	-	25	ns
RESET# inactive to BIT_CLK Startup delay	$T_{rst2clk}$	162.8	-	-	ns
SYNC active high pulse width	T_{sync_high}	1.0	-	-	us
SYNC inactive to BIT_CLK startup delay	$T_{sync2clk}$	162.8	-	-	ns
End of Slot 2 to BIT_CLK, SDATA_IN low	T_{s2_pdown}	-	-	1.0	us
BIT_CLK frequency	-	-	12.288	-	MHz
BIT_CLK period	T_{clk_period}	-	81.4	-	ns
BIT_CLK output jitter	-	-	-	750	ps
BIT_CLK high pulse width	T_{clk_high}	36	40.7	45	ns
BIT_CLK low pulse width	T_{clk_low}	36	40.7	45	ns
SYNC frequency	-	-	48.0	-	kHz

SYNC period	Tsync_period	-	20.8	-	us
SYNC high pulse width	Tsync_high	-	1.3	-	us
SYNC low pulse width	Tsync_low	-	19.5	-	us
Output Valid Delay from rising edge of BIT_CLK	tco	-	-	15	ns
Input Setup to falling edge of BIT_CLK	tsetup	10	-	-	ns
Input Hold from falling edge of BIT_CLK	thold	10	-	-	ns
BIT_CLK combined rise or fall plus flight time (Primary Codec to Controller or Secondary)	-	-	-	7	ns
SDATA combined rise or fall plus flight time (Output to Input)	-	-	-	7	ns
BIT_CLK rise time	Triseclk	-	-	6	ns
BIT_CLK fall time	Tfallclk	-	-	6	ns
SYNC rise time	Trisesync	-	-	6	ns
SYNC fall time	Tfallsync	-	-	6	ns
SDATA_IN rise time	Trisedin	-	-	6	ns
SDATA_IN fall time	Tfalldin	-	-	6	ns
SDATA_OUT rise time	Trisedout	-	-	6	ns
SDATA_OUT fall time	Tfalldout	-	-	6	ns

- (1). Worst case duty cycle restricted to 45/55
- (2). Combined rise or fall plus flight times are provided for worst case scenario modeling purpose
- (3). BIT_CLK rise/fall times with an external load of 75 pF
- (4). SYNC and SDATA_OUT rise/fall times with a external load of 75 pF
- (5). SDATA_IN rise/fall times with an external load of 60 pF
- (6). Rise is from 10% to 90% of Vdd (Vol to Voh)
- (7). Fall is from 90% to 10% of Vdd (Voh to Vol)

5.12.11. SCR AC Electrical Characteristics

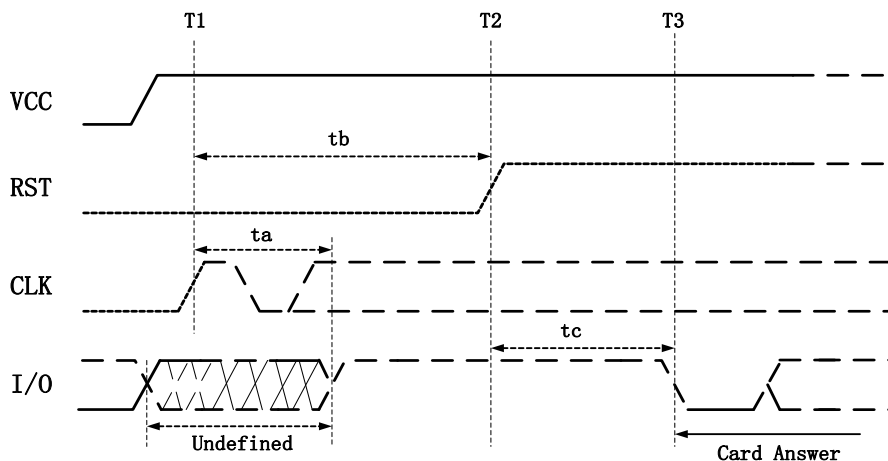

Figure 5-49. SCR Activation and Cold Reset Timing

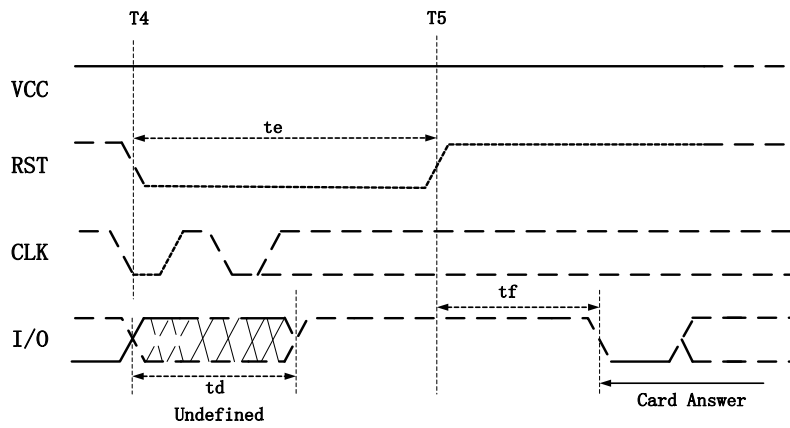

Figure 5-50. SCR Warm Reset Timing

Table 5-44. SCR Timing Constants

Symbol	Min	Type	Max	Unit
ta	-	-	200/f	us
tb	400/f	-	-	us
tc	400/f	-	40000/f	us
td	-	-	200/f	us
te	400/f	-	-	us
tf	400/f	-	40000/f	us

- (1). Activation: Before time T1
- (2). Cold Reset: After time T1
- (3). T1: The clock signal is applied to CLK at time T1.
- (4). T2: The RST is put to state H.
- (5). T3: The card begin answer at time T3
- (6). ta: The card shall set I/O to state H within 200 clock cycles (delay ta) after the clock signal is applied to CLK (at time T1+ta).
- (7). tb: The cold reset results from maintaining RST at state L for at least 400 clock cycles (delay tb) after the clock signal is applied to CLK (at time T1+tb).
- (8). tc: The answer on I/O shall begin between 400 and 40000 clock cycles (delay tc) after the rising edge of the signal on RST (at time T2+tc).
- (9). td: The card shall set I/O to state H within 200 clock cycles (delay td) after state L is applied to RST (at time T4+td).
- (10). te: The controller initiates a warm reset (at time T4) by putting RST to state L for at least 400 clock cycles (delay te) while VCC remains powered and CLK provided with a suitable and stabled clock signal.
- (11). tf: The card answer on I/O shall begin between 400 and 40000 clock cycles (delay tf) after the rising edge of the signal on RST (at time T5+tf).
- (12). f is the frequency of clock.

5.13. Power-up and Power-down Sequence

The following figure shows an example of the power-up sequence for A40i device. During the entire power-up sequence, the AP_RESET# pin must be held on low until all power domains are stable. The other power domains not in Figure 5-51 can be turned on upon the software request.

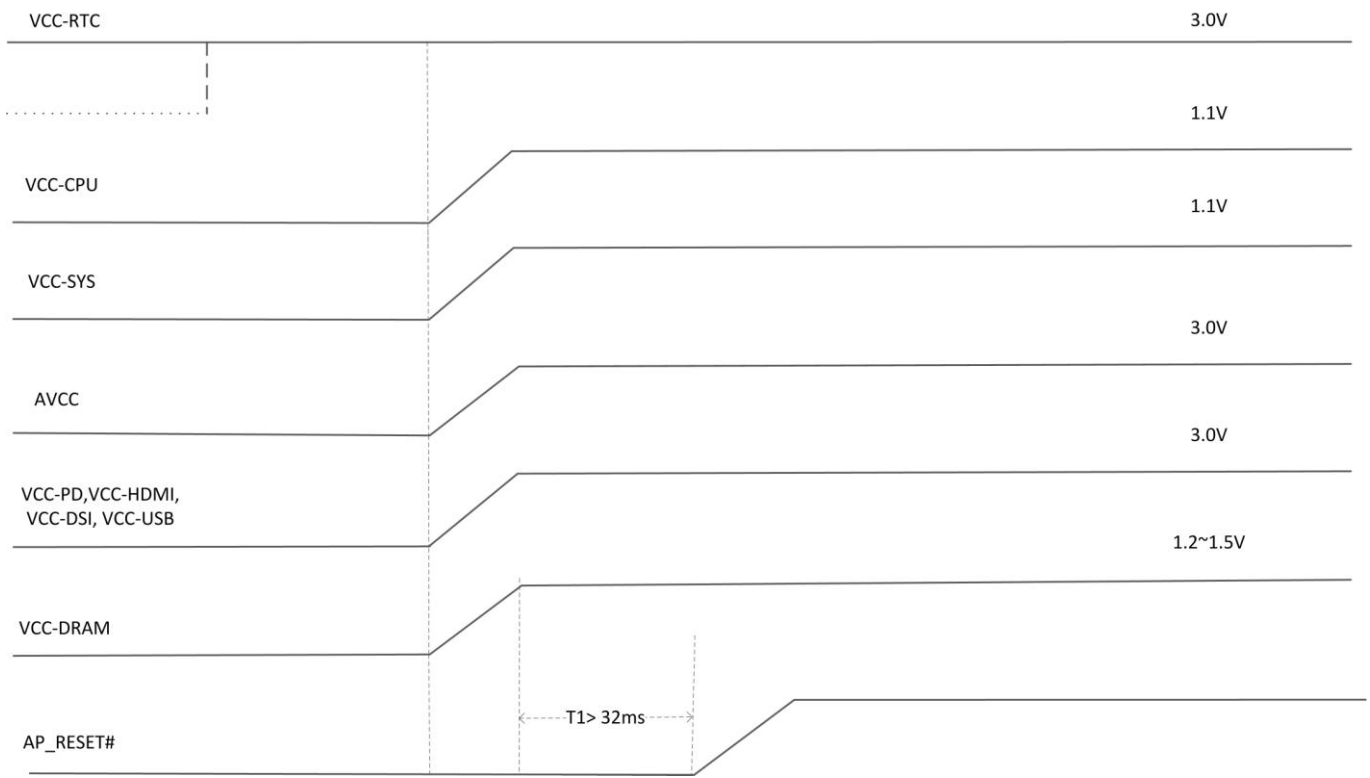

Figure 5-51. A40i Power Up Sequence

The power down solution is achieved by setting AP_RESET# to 0. When AP_RESET# powered down, then all power supplies start ramp down except VCC_RTC. The ramping down rate is decided by the load on the power supply.

6. Package Thermal Characteristics

Table 6-1 shows thermal resistance parameters of the A40i. The following thermal resistance characteristics in Table 6-1 is based on JEDEC JESD51 standard, because the actual system design and temperature could be different with JEDEC JESD51 , the simulating result data is a reference only, please prevail in the actual application condition test.



NOTE

Test condition: four-layer board(2s2p), natural convection, no air flow.

Table 6-1. A40i Thermal Resistance Characteristics

Symbol	Parameter	Min	Typ	Max	Unit
θ_{JA}	Junction-to-Ambient Thermal Resistance	-	24	-	°C/W
θ_{JB}	Junction-to-Board Thermal Resistance	-	TBD	-	°C/W
θ_{JC}	Junction-to-Case Thermal Resistance	-	TBD	-	°C/W

(1). °C/W : degrees Celsius per watt.

7. Pin Assignment

7.1. Pin Map

For A40i, FBGA 468 balls ,16 x 16 mm, 0.65 pitch package is offered. The pin maps are illustrated in Figure 7-1 for this package.

	1	2	3	4	5	6	7	8	9	10	11	12	13	14	15	16	17	18	19	20	21	22	23	24			
A	GND	SDQ11	SDQ9	SDQS1P	SDQ8	SDQ10	SDQM2	SDQ18	SDQ23	SDQS2P		SDQM3	SDQ25	SDQ27	SDQS3P	SDQ24	SDQ26	PH26		X32KIN	PH15	PH10	PH9	GND	A		
B	SDQM1	SDQ14	SDQ12	SDQS1N	SDQ15	SDQ13	SDQ16	GND	SDQ21	SDQS2N	SDQ20	GND	SDQ28	SDQ30	SDQS3N	SDQ31	SDQ29	PH24	PH27	X32KOUT	PH14	PH7	PH8	PH6	B		
C	SDQ6	SDQ7	SODT1	GND	SCAS/SA0	SCKE0	SCKP	SCKN	SDQ19	GND	SDQ17	SDQ22	SA12	SA6	GND	SBA0/SA7	GND	PH18	PH23	NMI	PH11	PH13	PH4	PH5	C		
D	SDQ3	SDQ1	SCKE1			SODT0	GND		SVREF							SA8	SBA2	PH17	PH21		PH16	PH12	PH0	PH2	D		
E	SDQS0P	SDQS0N	GND	SA15/SCS1		SA4/SA11	SA11/SA4	SRST	SA14	GND	SA10	SA5	GND	SBA1	SRAS	GND	SA9	PH25	PH19			PH3	PH1		E		
F	SDQ5	SDQ0	SCS0	SA3	GND	SA0/SCAS	GND	GND	GND	GND	GND	GND	SA7/SBA0	GND			GND	PH20			PB21	PB22	PB23	PB20	F		
G	SDQ2	SDQ4	SDQM0		SA2	SWE	GND	GND	GND	GND	VCC-DRAM	VCC-DRAM	GND	VCC-DRAM	VCC-DRAM	VCC-DRAM	PH22			PB12	PB13	PB14	PB17	PB18	PB19	G	
H	SZQ	GND	SA13	GND	SA1	GND	VCC-DRAM	GND	GND	VCC-DRAM	GND	VCC-DRAM	VCC-DRAM	GND	GND	RTC-VIO	VCC-RTC						PB15	PB16		H	
J	MDSI-D0P	MDSI-D0N	MDSI-D2P	MDSI-D2N			GND	VCC-DRAM	GND	GND	GND	GND	GND	GND	VCC-IO	VCC-IO	VCC-IO				PB11	PB7	PB8	PB9	PB10	PB4	J
K	MDSI-D1P	MDSI-D1N	MDSI-D3P	MDSI-D3N			JTAG-SEL	GND	GND	GND	GND	GND	GND	GND	GND	VCC-IO	VCC-IO				PB5	PB6	PB1	PB2	PB3	K	
L	MDSI-CKP	MDSI-CKN	PD12	PD11	PD10		FEL	VCC-DSI	GND	GND	GND	GND	GND	GND	GND	VCC-IO	VCC-PA						PB0	PA0		L	
M	PD1	PD0	PD3	PD13			VDD-EFUSEBP	VDD-EFUSE	GND	GND	VDD-SYS	VDD-SYS	GND	GND	GND	GND	GND				PA1	PA5	PA4	PA3	PA2	PA6	M
N		PD2	PD14	PD15			VCC-PD	VCC-PD	GND-TVOUT	GND	VDD-SYS	VDD-SYS	GND	VDD-CPU	VDD-CPU	VDD-CPU	VDD-CPUFB				PA12	PA11	PA10	PA9	PA8	PA7	N
P	PD4	PD5	PD7	PD17	PD16		VCC-TVIN	VCC-TVOUT	GND-TVIN	GND	GND	VDD-SYS	GND	GND	VDD-CPU	VDD-CPU	VDD-CPU	GND						PA14	PA13		P
R	PD6	PD8	PD9	PD19	PD18		AVCC	VRA1	VCC-HP	GND	GND	GND	VDD-SYS	GND	VDD-CPU	VDD-CPU	GND				PA17	PA16	PA15	PI21	RESET	R	
T		PD20	PD23	PD24	PD25		VRA2	VRP	VDD-SATA	VRP-TVIN	VCC-USB	VCC-PF	VCC-PLL		VCC-PC	GND	VCC-PG				PH16		PI20	PI19	PI17	PI18	T
U	PD21	PD22			PD26	PD27		VCC-HDMI	VDD25-SATA	VRN-TVIN	HHPD	TEST	GND	GND	VCC-PC	GND	VCC-PE				PI12			PI15	PI14		U
V	TVOUT0	TVOUT1	TVOUT2	TVOUT3	PHONEOUTN	PHONEOUTP	AGND	GND-HP	HSCL	HCEC													PI13	PI9	PI10	PI11	V
W		TVIN0	TVIN3	HPCOMFB				HPBP	HSDA	REXT-SATA	PF2		PF5			PC4	PE2				PE3	PI8		PI5	PI6	PI7	W
Y	TVIN1	TVIN2	HPCOM								PF1		PF4	PC16		PC22	PE1				PE4	PG1		PI3	PI4		Y
AA	HPOUTR	HPOUTL	LINEINL	KEYADC1		TPX1	SATA-CLKM	SATA-RXP	SATA-TXP	USB2-DM	PF0		PF3	PC21		PC19	PE0				PE5	PG0		PI0	PI1	PI2	AA
AB		LINEINR	MICIN1	TPY2	TPY1	TPX2	SATA-CLKP	SATA-RXM	SATA-TXM	USB2-DP	PC0	PC3	PC7	GND	PC9	PC18	PC23	PC20	PE6	PE10	PG2	PG4	PG10	PG11		AB	
AC	FMINL	FMINR	VMIC	HTXCN	HTX0N	HTX1N	HTX2N	USB0-DM	USB1-DM	PC1	X24MOUT	PC6	PC11	PC8	PC13	PC17	PC10	PC5	PE7	PE11	PG3	PG5	PG8	PG9	AC		
AD	GND	MICIN2	KEYADC0	HTXCP	HTX0P	HTX1P	HTX2P	USB0-DP	USB1-DP	PC2	X24MIN		PC24	PC12		PC14	PC15		PE8	PE9		PG6	PG7	GND	AD		

Figure 7-1. A40i Pin Map

7.2. Package Dimension

Figure 7-2 shows the top, bottom, and side views of A40i package dimension.

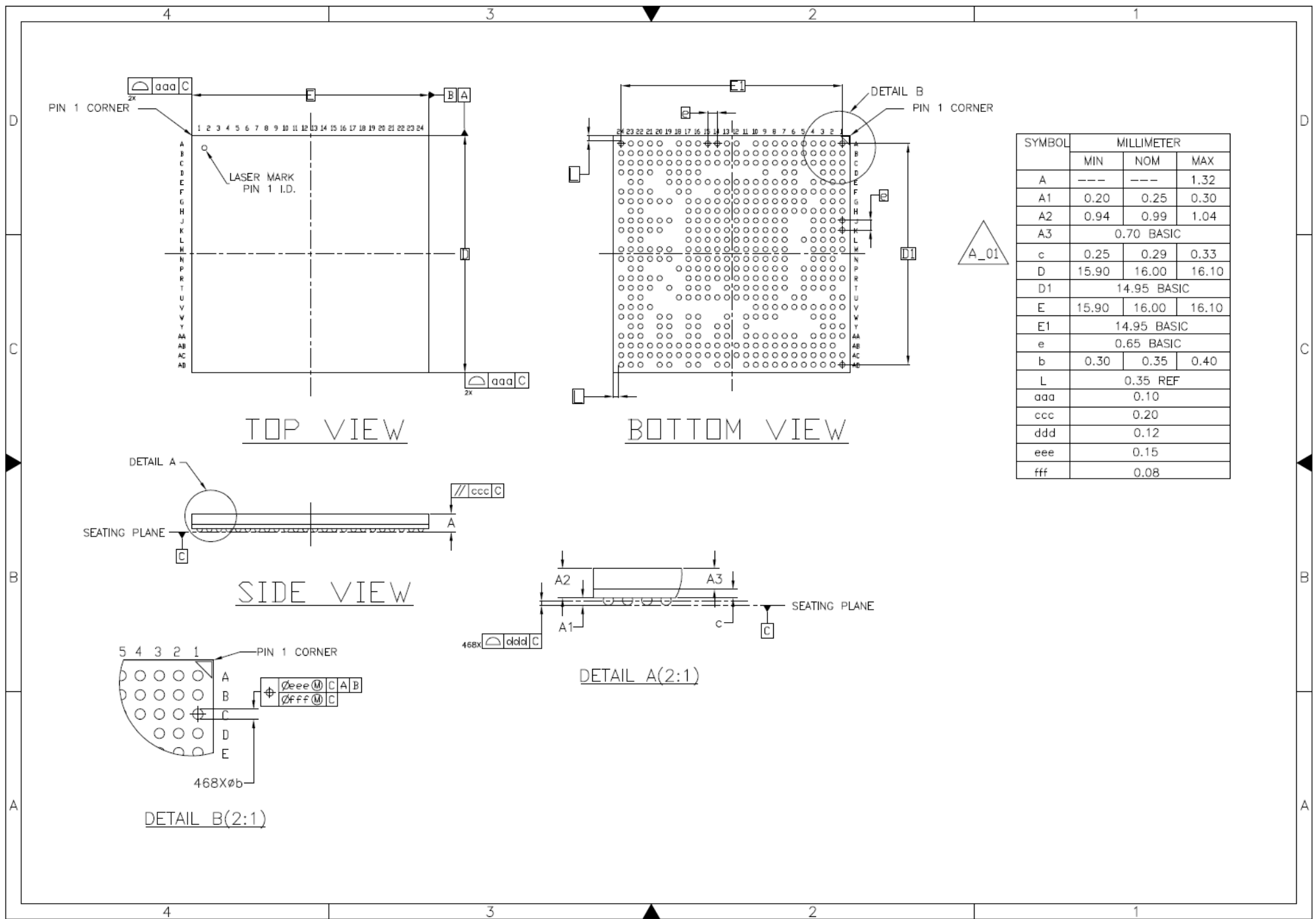

Figure 7-2. A40i Package Dimension

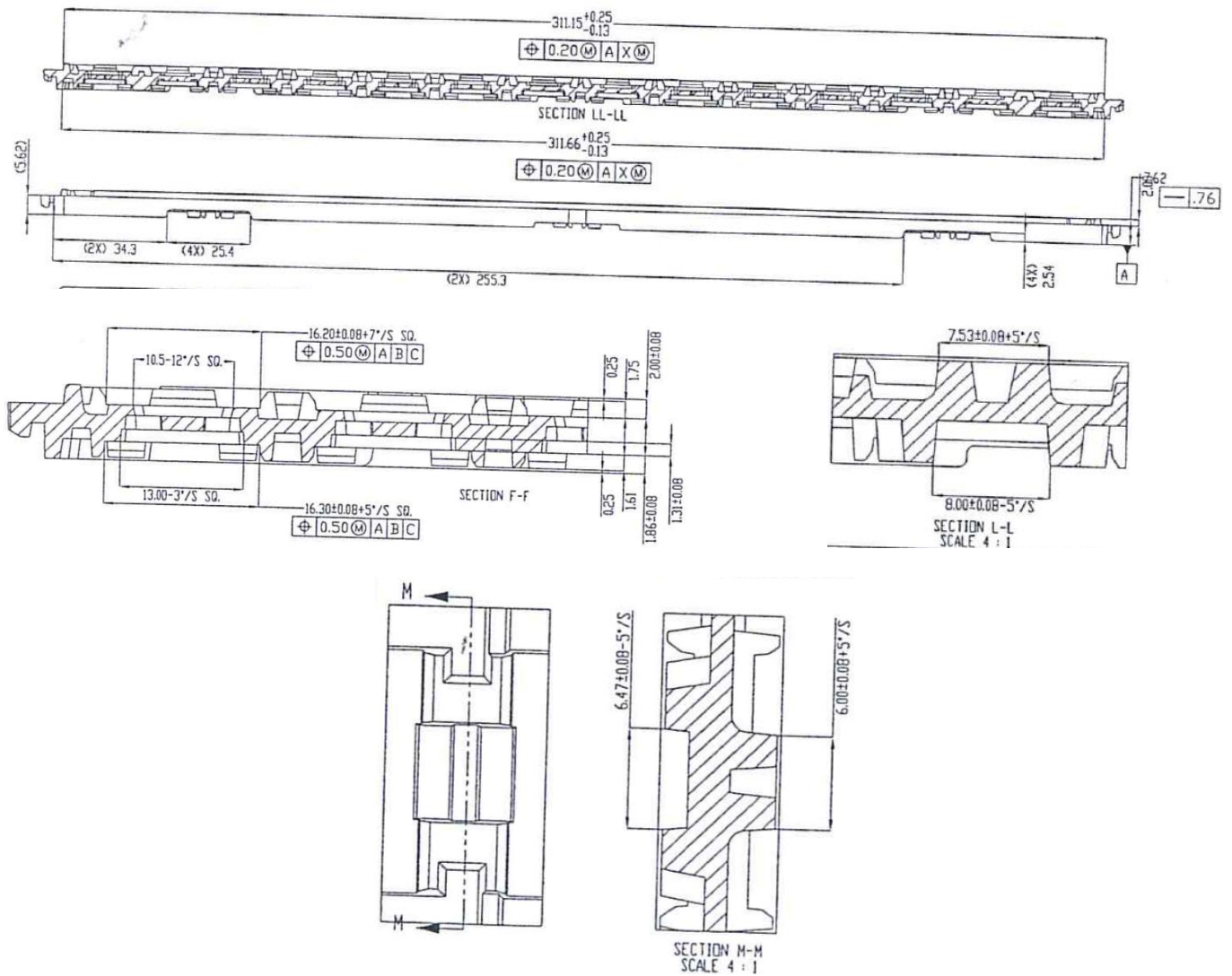

Figure 8-1. Tray Dimension Drawing

8.2. Carrier

Reliability is affected if any condition specified in Section 8.2.2 and Section 8.2.3 has been exceeded.

8.2.1. Matrix Tray Information

A package’s MSL indicates its ability to withstand exposure after it is removed from its shipment bag, a low MSL device sample can be exposed on the factory floor longer than a high MSL device sample. All MSL are defined in Table 8-3.

Table 8-3. MSL Summary

MSL	Out-of-bag floor life	Comments
1	Unlimited	≤30°C / 85%RH
2	1 year	≤30°C / 60%RH
2a	4 weeks	≤30°C / 60%RH
3	168 hours	≤30°C / 60%RH
4	72 hours	≤30°C / 60%RH
5	48 hours	≤30°C / 60%RH
5a	24 hours	≤30°C / 60%RH
6	Time on Label(TOL)	≤30°C / 60%RH



NOTE

The A40i device samples are classified as MSL3.

8.2.2. Bagged Storage Conditions

The shelf life of the A40i device samples are defined in Table 8-4.

Table 8-4. Bagged Storage Conditions

Packing mode	Vacuum packing
Storage temperature	20°C ~26°C
Storage humidity	40%~60%RH
Shelf life	12 months

8.2.3. Out-of-bag Duration

It is defined by the device MSL rating, the out-of-bag duration of the A40i are as follows.

Table 8-5. Out-of-bag Duration

Storage temperature	20°C ~26°C
Storage humidity	40%~60%RH
Moisture sensitive level(MSL)	3
Floor life	168 hours

For no mention of storage rules in this document, please refer to the latest *IPC/JEDEC J-STD-020C*.

8.3. Baking

It is not necessary to bake the A40i if the conditions specified in Section 8.2.2 and Section 8.2.3 have not been exceeded. It is necessary to bake the A40i if any condition specified in Section 8.2.2 and Section 8.2.3 has been exceeded.

It is necessary bake the A40i if the storage humidity condition has been exceeded, we recommend that the device sample removed from its shipment bag more than 2 days shall be baked to guarantee production.

Baking conditions: 125°C, 8 hours, nitrogen protection. Note that baking should not exceed 3 times.

9. Reflow Profile

All Allwinner chips provided for clients are lead-free RoHS-compliant products.

The reflow profile recommended in this document is a lead-free reflow profile that is suitable for pure lead-free technology of lead-free solder paste. If customers need to use lead solder paste, please contact with Allwinner FAE.

The lead-free reflow profile conditions are given in Table 9-1. The table is for reference only.

Table 9-1. Lead-free Reflow Profile Conditions

Profile Stage	Description	Symbol	High Temperature Condition Limits
Preheat	Initial ramp temperature range	A	25°C to 150°C
	Initial ramp rate	B	< 3°C/s
Soak	Soak temperature range	C	150°C to 180°C
	Soak time	D	40s to 60s
Reflow	Liquidus temperature	E	217°C
	Time above liquidus	F	60s to 90s
	Peak temperature	G	235°C to 250°C
Cool down	Cool down temperature rate	H	> -4°C/s

Figure 9-1 shows the typical lead-free reflow profile.

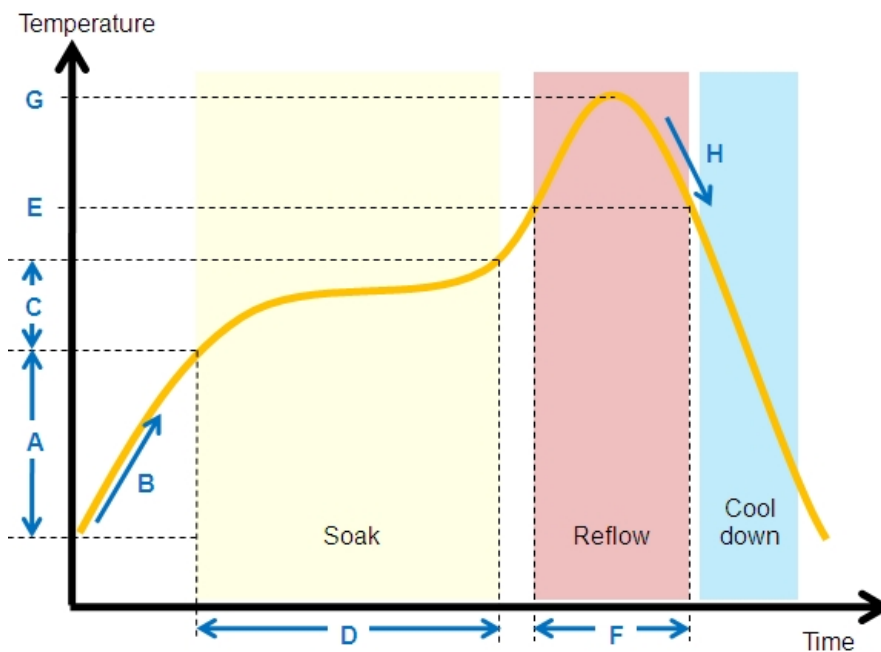

Figure 9-1. Typical Lead-free Reflow Profile



NOTE

The above reflow profile is solder joint testing result, it is for reference only, please adjust depending on actual production conditions.

The method of measuring the reflow soldering process is as follows.

Fix the thermocouple probe of the temperature measuring line at the connection point between the pin (solderable end) of the packaged device and the pad by using high-temperature solder wire or high-temperature tape, fix the packaged device at the pad by using high-temperature tape or other methods, and cover over the thermocouple probe. See Figure 9-2.

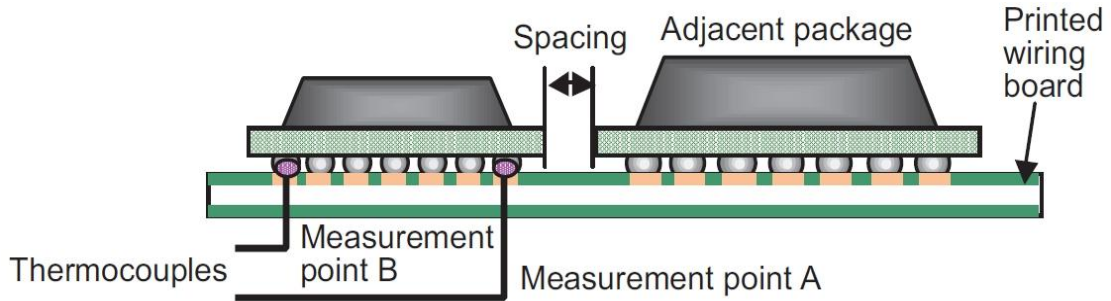

Figure 9-2. Measuring the Reflow Soldering Process



NOTE

To measure the temperature of QFP-packaged chip, place the temperature probe directly at the pin.

If possible, the more accurate measuring way is to drill the packaged device, or drill the PCB, and fix the thermocouple probe through the drilled hole at the pad.

10. FT and IQC Test

10.1. FT Test

FT test includes two parts, module verification and linux system testing. For module verification, it verifies the logic function of each module; for linux system testing, it mainly tests CPU, DDR, memory test and linpack, etc.

10.2. IQC Test

IQC test system is used for sampling inspection before delivery, it is the final test for chip shipment before delivery to the customer. IQC test system includes QA test and QC test.

10.2.1. QA Test

QA test is a testing for each function module of chip based-on Android 4.4.2 system, which can judge whether chip can reach production standard by system total running results, video playback fluency, single module testing fluency.

10.2.2. QC Test

QC test is used to test each module code booting from nand flash, and run schedule by using PC control code, then read the return value of each module testing. If the return value is PASS, then continue to perform the next module testing; or else stop testing and remind the testing module FAIL.

11. Part Reliability

Table 11-1. Package Reliability Results

Test Item	Standard	Condition	Sample Size	Result
Moisture sensitive level (MSL)	J-STD 020D	MSL 3, refer to PRC Total samples from three different lots	45	Pass
Preconditioning (PRC)	JESD22-A113F	Bake(125°C, 24 hrs), Soak(60°C/60%RH, 40 hrs), Reflow(260°C), 3 times Operating before TCT/uHAST Total samples from three different lots	90	Pass
Temperature cycle test (TCT)	JESD22-A104C, JESD74	Temperature: -65°C to 150°C Soak time at minimum/maximum temperature: 15 min 500 cycles Total samples from three different lots	45	Pass
Unbiased highly accelerated stress test (uHAST)	JESD22-A118	130°C/85%RH 96 hrs Total samples from three different lots	45	Pass
High temperature storage life(HTSL)	JESD22-A103	150°C, 168 hrs Total samples from three different lots	45	Pass

Table 11-2. Silicon Reliability Results

Test Item	Standard	Condition	Sample Size	Result
ESD-HBM	JS-001-2014	All pins $\geq \pm 4000V$ Total samples from one lot	3	Pass
ESD-CDM	JS-002-2014	All pins $\geq \pm 500V$ Total samples from one lot	6	Pass
Latch-up	JESD78D	Inom $\pm 200mA$, 1.5 x VddMax Total samples from one lot	9	Pass
High temperature operating life(HTOL)	JESD22-A108	Tj=125(-0/+5)°C, 500hrs Total samples from three different lots	45	Pass

12. Part Marking

Figure 10-1 shows the A40i marking.

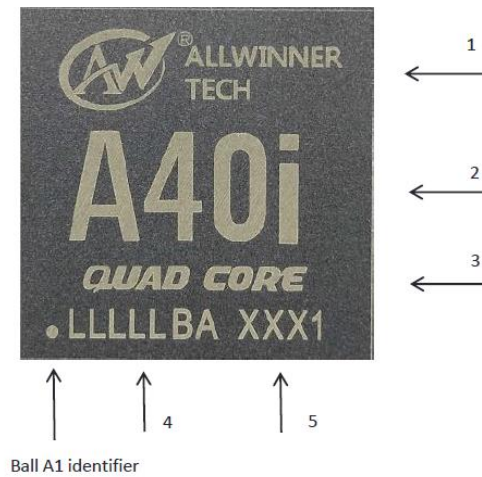

Figure 12-1. A40i Marking

Table 10-1 describes the T7 marking definitions.

Table 12-1. A40i Marking Definitions

No.	Marking	Description	Fixed/Dynamic
1	ALLWINNER TECH	Allwinner logo or name	Fixed
2	A40i	Product name	Fixed
3	QUAD CORE	CPU core flag	Fixed
4	LLLBA	Lot number	Dynamic
5	XXX1	Data code	Dynamic

13. Qualification Sample Description

Device Information:

1	DEVICE/TYPE NO.	A40i
2	PACKAGE BODY SIZE	16 x 16 mm ²
3	SOLDER BALL PITCH	0.65 mm
4	WAFER DIA	12 inches
5	DIE THICKNESS	10 mil
6	DIE SIZE(w/o scribe line width)	5580 x 5697 um ²
7	WAFER PASSIVATION	NA
8	BUMP COMPOSITION	NA
9	FAB PROCESS	40 nm

Assembly Material:

1	SUBSTRATE	KINSUS_AUS410_OSP_OSP
2	FLUX	WF-6317
3	UNDERFILL	NA
4	COMPOUND	G311AC
5	SOLDER BALL	SN98.25/AG1.2/CU0.5/NIO.05
6	TRAY	6*14_84



Copyright © 2018 Allwinner Technology Co.,Ltd. All Rights Reserved.

Allwinner Technology Co.,Ltd.

No.9 Technology Road 2,High-Tech Zone,

Zhuhai, Guangdong Province, China

Contact US:

Service@allwinnertech.com

www.allwinnertech.com