



Allwinner A64 User Manual

Version 1.1

Jun.25,2015

Declaration

THIS DOCUMENTATION IS THE ORIGINAL WORK AND COPYRIGHTED PROPERTY OF ALLWINNER TECHNOLOGY (“ALLWINNER”). REPRODUCTION IN WHOLE OR IN PART MUST OBTAIN THE WRITTEN APPROVAL OF ALLWINNER AND GIVE CLEAR ACKNOWLEDGEMENT TO THE COPYRIGHT OWNER.

THE INFORMATION FURNISHED BY ALLWINNER IS BELIEVED TO BE ACCURATE AND RELIABLE. ALLWINNER RESERVES THE RIGHT TO MAKE CHANGES IN CIRCUIT DESIGN AND/OR SPECIFICATIONS AT ANY TIME WITHOUT NOTICE. ALLWINNER DOES NOT ASSUME ANY RESPONSIBILITY AND LIABILITY FOR ITS USE. NOR FOR ANY INFRINGEMENTS OF PATENTS OR OTHER RIGHTS OF THE THIRD PARTIES WHICH MAY RESULT FROM ITS USE. NO LICENSE IS GRANTED BY IMPLICATION OR OTHERWISE UNDER ANY PATENT OR PATENT RIGHTS OF ALLWINNER. THIS DOCUMENTATION NEITHER STATES NOR IMPLIES WARRANTY OF ANY KIND, INCLUDING FITNESS FOR ANY PARTICULAR APPLICATION.

THIRD PARTY LICENCES MAY BE REQUIRED TO IMPLEMENT THE SOLUTION/PRODUCT. CUSTOMERS SHALL BE SOLELY RESPONSIBLE TO OBTAIN ALL APPROPRIATELY REQUIRED THIRD PARTY LICENCES. ALLWINNER SHALL NOT BE LIABLE FOR ANY LICENCE FEE OR ROYALTY DUE IN RESPECT OF ANY REQUIRED THIRD PARTY LICENCE. ALLWINNER SHALL HAVE NO WARRANTY, INDEMNITY OR OTHER OBLIGATIONS WITH RESPECT TO MATTERS COVERED UNDER ANY REQUIRED THIRD PARTY LICENCE.

Revision History

Version	Date	Description
V1.0	Mar.30,2015	Initial Release Version
V1.1	Jun.26,2015	Revise the feature of display output

Table of Contents

Declaration.....	2
Revision History	3
Table of Contents	4
Chapter 1 About This Documentation	58
1.1. Documentation Overview	58
1.2. Acronyms and abbreviations	58
Chapter 2 Overview.....	60
2.1. Processor Features.....	61
2.1.1. CPU Architecture.....	61
2.1.2. GPU Architecture	61
2.1.3. Memory Subsystem	61
2.1.3.1. Boot ROM	61
2.1.3.2. SDRAM	62
2.1.3.3. NAND Flash	62
2.1.3.4. SD/MMC	62
2.1.4. System Peripheral	62
2.1.4.1. Timer.....	62
2.1.4.2. High Speed Timer.....	63
2.1.4.3. RTC.....	63
2.1.4.4. GIC.....	63
2.1.4.5. DMA.....	63

2.1.4.6.	CCU	63
2.1.4.7.	PWM	64
2.1.4.8.	Thermal Sensor	64
2.1.4.9.	KEYADC	64
2.1.4.10.	Crypto Engine(CE)	64
2.1.4.11.	Security ID.....	64
2.1.4.12.	CPU Configuration	65
2.1.5.	Display Subsystem.....	65
2.1.5.1.	DE.....	65
2.1.5.2.	Display Output	65
2.1.6.	Video Engine	65
2.1.6.1.	Video Decoding.....	65
2.1.6.2.	Video Encoding	66
2.1.7.	Image In	66
2.1.7.1.	CSI	66
2.1.8.	Audio Subsystem.....	66
2.1.8.1.	Audio Codec.....	66
2.1.8.2.	One Wire Audio(OWA)	67
2.1.8.3.	I2S/PCM	67
2.1.9.	External Peripherals.....	68
2.1.9.1.	USB.....	68
2.1.9.2.	EMAC	68
2.1.9.3.	UART	68
2.1.9.4.	SPI	68

2.1.9.5.	Two Wire Interface(TWI)	69
2.1.9.6.	CIR.....	69
2.1.9.7.	Reduced Serial Bus(RSB™)	69
2.1.9.8.	TS	69
2.1.9.9.	SCR.....	70
2.1.10.	Package	70
2.2.	System Block Diagram.....	71
Chapter 3	System.....	72
3.1.	Memory Mapping	73
3.2.	Boot System	76
3.3.	CCU	77
3.3.1.	Overview	77
3.3.2.	Functionalities Description	77
3.3.2.1.	System Bus.....	77
3.3.2.2.	Bus clock tree.....	79
3.3.2.3.	Module clock tree	79
3.3.3.	Typical Applications.....	81
3.3.4.	Register List.....	81
3.3.5.	Register Description.....	84
3.3.5.1.	PLL_CPUX Control Register (Default Value: 0x00001000)	84
3.3.5.2.	PLL_Audio Control Register (Default Value: 0x00035514)	85
3.3.5.3.	PLL_VIDEO0 Control Register (Default Value: 0x03006207)	86
3.3.5.4.	PLL_VE Control Register (Default Value: 0x03006207)	87
3.3.5.5.	PLL_DDR0 Control Register (Default Value: 0x00001000)	88

3.3.5.6. PLL_PERIPH0 Control Register (Default Value: 0x00041811)..... 89

3.3.5.7. PLL_PERIPH1 Control Register (Default Value: 0x00041811)..... 90

3.3.5.8. PLL_VIDEO1 Control Register (Default Value: 0x03006207) 92

3.3.5.9. PLL_GPU Control Register (Default Value: 0x03006207) 93

3.3.5.10. PLL_MIPI Control Register (Default Value: 0x00000515)..... 94

3.3.5.11. PLL_HSIC Control Register (Default Value: 0x03001300)..... 95

3.3.5.12. PLL_DE Control Register (Default Value: 0x03006207) 96

3.3.5.13. PLL_DDR1 Control Register (Default Value: 0x00001800) 97

3.3.5.14. CPUX/AXI Configuration Register (Default Value: 0x00010300) 98

3.3.5.15. AHB1/APB1 Configuration Register (Default Value: 0x00001010) 99

3.3.5.16. APB2 Configuration Register (Default Value: 0x01000000) 100

3.3.5.17. AHB2 Configuration Register (Default Value: 0x00000000)..... 100

3.3.5.18. Bus Clock Gating Register0 (Default Value: 0x00000000)..... 100

3.3.5.19. Bus Clock Gating Register1 (Default Value: 0x00000000)..... 102

3.3.5.20. Bus Clock Gating Register2 (Default Value: 0x00000000)..... 103

3.3.5.21. Bus Clock Gating Register3 (Default Value: 0x00000000)..... 104

3.3.5.22. Bus Clock Gating Register4 (Default Value: 0x00000000)..... 105

3.3.5.23. THS Clock Register (Default Value: 0x00000000) 106

3.3.5.24. NAND Clock Register (Default Value: 0x00000000) 106

3.3.5.25. SMHC0 Clock Register (Default Value: 0x00000000) 107

3.3.5.26. SMHC1 Clock Register (Default Value: 0x00000000) 108

3.3.5.27. SMHC2 Clock Register (Default Value: 0x00000000) 108

3.3.5.28. TS Clock Register (Default Value: 0x00000000)..... 109

3.3.5.29. CE Clock Register (Default Value: 0x00000000) 109

3.3.5.30.	SPI0 Clock Register (Default Value: 0x00000000)	110
3.3.5.31.	SPI1 Clock Register (Default Value: 0x00000000)	111
3.3.5.32.	I2S/PCM 0 Clock Register (Default Value: 0x00000000)	112
3.3.5.33.	I2S/PCM 1 Clock Register (Default Value: 0x00000000)	112
3.3.5.34.	I2S/PCM 2 Clock Register (Default Value: 0x00000000)	112
3.3.5.35.	OWA Clock Register (Default Value: 0x00000000).....	113
3.3.5.36.	USBPHY Configuration Register (Default Value: 0x00000000).....	113
3.3.5.37.	DRAM Configuration Register (Default Value: 0x00000000)	114
3.3.5.38.	PLL_DDR Configuration Register (Default Value: 0xCCCA0000).....	115
3.3.5.39.	MBUS Reset Register (Default Value: 0x80000000).....	116
3.3.5.40.	DRAM Clock Gating Register (Default Value: 0x00000000)	116
3.3.5.41.	DE Clock Gating Register (Default Value: 0x00000000)	117
3.3.5.42.	TCON0 Clock Register (Default Value: 0x00000000)	117
3.3.5.43.	TCON1 Clock Register (Default Value: 0x00000000)	117
3.3.5.44.	DEINTERLACE Clock Register (Default Value: 0x00000000).....	118
3.3.5.45.	CSI_MISC Clock Register (Default Value: 0x00000000).....	118
3.3.5.46.	CSI Clock Register (Default Value: 0x00000000)	119
3.3.5.47.	VE Clock Register (Default Value: 0x00000000)	120
3.3.5.48.	AC Digital Clock Register (Default Value: 0x00000000)	120
3.3.5.49.	AVS Clock Register (Default Value: 0x00000000).....	120
3.3.5.50.	HDMI Clock Register (Default Value: 0x00000000).....	121
3.3.5.51.	HDMI Slow Clock Register (Default Value: 0x00000000)	121
3.3.5.52.	MBUS Clock Register (Default Value: 0x00000000)	121
3.3.5.53.	MIPI_DSI Clock Register (Default Value: 0x00000000)	122

3.3.5.54. GPU Clock Register (Default Value: 0x00000000) 122

3.3.5.55. PLL Stable Time Register0 (Default Value: 0x000000FF) 123

3.3.5.56. PLL Stable Time Register1 (Default Value: 0x000000FF) 123

3.3.5.57. PLL_PERIPH1 Bias Register (Default Value: 0x10100010) 123

3.3.5.58. PLL_CPUX Bias Register (Default Value: 0x08100200) 124

3.3.5.59. PLL_AUDIO Bias Register (Default Value: 0x10100000) 124

3.3.5.60. PLL_VIDEO0 Bias Register (Default Value: 0x10100000) 125

3.3.5.61. PLL_VE Bias Register (Default Value: 0x10100000) 125

3.3.5.62. PLL_DDR0 Bias Register (Default Value: 0x81104000) 125

3.3.5.63. PLL_PERIPH0 Bias Register (Default Value: 0x10100010) 126

3.3.5.64. PLL_VIDEO1 Bias Register (Default Value: 0x10100000) 126

3.3.5.65. PLL_GPU Bias Register (Default Value: 0x10100000) 127

3.3.5.66. PLL_MIPI Bias Register (Default Value: 0XF8100400) 127

3.3.5.67. PLL_HSIC Bias Register (Default Value: 0x10100000) 128

3.3.5.68. PLL_DE Bias Register (Default Value: 0x10100000) 128

3.3.5.69. PLL_DDR1 Bias Register (Default Value: 0x10010000) 128

3.3.5.70. PLL_CPUX Tuning Register (Default Value: 0x0A101000) 129

3.3.5.71. PLL_DDR0 Tuning Register (Default Value: 0x14880000) 129

3.3.5.72. PLL_MIPI Tuning Register (Default Value: 0x8A002000) 130

3.3.5.73. PLL_PERIPH1 Pattern Control Register (Default Value: 0x00000000) 131

3.3.5.74. PLL_CPUX Pattern Control Register (Default Value: 0x00000000) 131

3.3.5.75. PLL_AUDIO Pattern Control Register (Default Value: 0x00000000) 132

3.3.5.76. PLL_VIDEO0 Pattern Control Register (Default Value: 0x00000000) 133

3.3.5.77. PLL_VE Pattern Control Register (Default Value: 0x00000000) 133

- 3.3.5.78. PLL_DDR0 Pattern Control Register (Default Value: 0x00000000) 134
- 3.3.5.79. PLL_VIDEO1 Pattern Control Register (Default Value: 0x00000000) 134
- 3.3.5.80. PLL_GPU Pattern Control Register (Default Value: 0x00000000) 135
- 3.3.5.81. PLL_MIPI Pattern Control Register (Default Value: 0x00000000) 135
- 3.3.5.82. PLL_HSIC Pattern Control Register (Default Value: 0x00000000) 136
- 3.3.5.83. PLL_DE Pattern Control Register (Default Value: 0x00000000) 137
- 3.3.5.84. PLL_DDR1 Pattern Control Register0 (Default Value: 0x00000000) 137
- 3.3.5.85. PLL_DDR1 Pattern Control Register1 (Default Value: 0x00000000) 138
- 3.3.5.86. Bus Software Reset Register 0 (Default Value: 0x00000000)..... 138
- 3.3.5.87. Bus Software Reset Register 1 (Default Value: 0x00000000)..... 140
- 3.3.5.88. Bus Software Reset Register 2 (Default Value: 0x00000000)..... 141
- 3.3.5.89. Bus Software Reset Register 3 (Default Value: 0x00000000)..... 142
- 3.3.5.90. Bus Software Reset Register 4 (Default Value: 0x00000000)..... 142
- 3.3.5.91. CCU Security Switch Register (Default Value: 0x00000000) 143
- 3.3.5.92. PS Control Register (Default Value: 0x00000000)..... 144
- 3.3.5.93. PS Counter Register (Default Value: 0x00000000)..... 145
- 3.3.5.94. PLL Lock Control Register (Default Value: 0x00000000) 145
- 3.3.6. Programming Guidelines..... 147
 - 3.3.6.1. PLL..... 147
 - 3.3.6.2. BUS..... 147
 - 3.3.6.3. Clock Switch 147
 - 3.3.6.4. Gating and reset..... 147
- 3.4. CPU Configuration..... 148
 - 3.4.1. Overview 148

3.4.2.	Block Diagram	148
3.4.3.	Functionalities Description	149
3.4.3.1.	Signal Description	149
3.4.3.2.	L2 Idle Mode	149
3.4.3.3.	CPU Reset System	149
3.4.3.4.	Operation Principle	149
3.4.4.	Register List	149
3.4.5.	Register Description	150
3.4.5.1.	Cluster Control Register0 (Default Value: 0x80000000)	150
3.4.5.2.	Cluster Control Register1 (Default Value: 0x00000000)	151
3.4.5.3.	Cache Parameter Control Register0 (Default Value: 0x22222222)	151
3.4.5.4.	Cache Parameter Control Register1 (Default Value: 0x02022020)	152
3.4.5.5.	General Control Register0 (Default Value: 0x00000010)	152
3.4.5.6.	Cluster CPU Status Register (Default Value: 0x000E0000)	153
3.4.5.7.	L2 Status Register(Default Value: 0x00000000)	153
3.4.5.8.	Cluster Reset Control Register (Default Value: 0x11101101)	154
3.4.5.9.	Reset Vector Base Address Register0_L (Default Value: 0x00000000)	155
3.4.5.10.	Reset Vector Base Address Register0_H (Default Value: 0x00000000)	155
3.4.5.11.	Reset Vector Base Address Register1_L (Default Value: 0x00000000)	155
3.4.5.12.	Reset Vector Base Address Register1_H (Default Value: 0x00000000)	155
3.4.5.13.	Reset Vector Base Address Register2_L (Default Value: 0x00000000)	156
3.4.5.14.	Reset Vector Base Address Register2_H (Default Value: 0x00000000)	156
3.4.5.15.	Reset Vector Base Address Register3_L (Default Value: 0x00000000)	156
3.4.5.16.	Reset Vector Base Address Register3_H (Default Value: 0x00000000)	156

- 3.5. System Control..... 157
 - 3.5.1. Overview 157
 - 3.5.2. System Control Register List..... 157
 - 3.5.3. System Control Register Description..... 157
 - 3.5.3.1. Version Register 157
 - 3.5.3.2. EMAC Clock Register (Default Value: 0x00000000) 158
- 3.6. Timer..... 159
 - 3.6.1. Overview 159
 - 3.6.2. Block Diagram 159
 - 3.6.3. Operation Principle 160
 - 3.6.3.1. Timer reload and enable bit..... 160
 - 3.6.3.2. Timing requirement for Timer command 160
 - 3.6.3.3. Watchdog restart 161
 - 3.6.4. Timer Register List 161
 - 3.6.5. Timer Register Description 161
 - 3.6.5.1. Timer IRQ Enable Register (Default Value: 0x00000000)..... 161
 - 3.6.5.2. Timer IRQ Status Register (Default Value: 0x00000000)..... 162
 - 3.6.5.3. Timer 0 Control Register (Default Value: 0x00000004) 162
 - 3.6.5.4. Timer 0 Interval Value Register 163
 - 3.6.5.5. Timer 0 Current Value Register 163
 - 3.6.5.6. Timer 1 Control Register (Default Value: 0x00000004) 164
 - 3.6.5.7. Timer 1 Interval Value Register 165
 - 3.6.5.8. Timer 1 Current Value Register 165
 - 3.6.5.9. AVS Counter Control Register (Default Value: 0x00000000)..... 165

- 3.6.5.10. AVS Counter 0 Register (Default Value: 0x00000000) 166
- 3.6.5.11. AVS Counter 1 Register (Default Value: 0x00000000) 166
- 3.6.5.12. AVS Counter Divisor Register (Default Value: 0x05DB05DB) 166
- 3.6.5.13. Watchdog IRQ Enable Register (Default Value: 0x00000000) 167
- 3.6.5.14. Watchdog Status Register (Default Value: 0x00000000)..... 167
- 3.6.5.15. Watchdog Control Register (Default Value: 0x00000000)..... 168
- 3.6.5.16. Watchdog Configuration Register (Default Value: 0x00000001)..... 168
- 3.6.5.17. Watchdog Mode Register (Default Value: 0x00000000) 168
- 3.6.6. Programming Guidelines..... 169
 - 3.6.6.1. Timer 169
 - 3.6.6.2. Watchdog 169
- 3.7. R_Trusted Watchdog Timer 170
 - 3.7.1. Overview 170
 - 3.7.2. Block Diagram 170
 - 3.7.3. Functionalities Description 170
 - 3.7.3.1. TWD Reset..... 170
 - 3.7.3.2. NV-Counter 171
 - 3.7.4. TWD Register List 171
 - 3.7.5. R_TWD Register Description 172
 - 3.7.5.1. R_TWD Status Register (Default Value: 0x00000000)..... 172
 - 3.7.5.2. R_TWD Control Register (Default Value: 0x00000000)..... 172
 - 3.7.5.3. R_TWD Restart Register (Default Value: 0x00000000) 173
 - 3.7.5.4. R_TWD Low Counter Register (Default Value: 0x00000000) 173
 - 3.7.5.5. R_TWD High Counter Register (Default Value: 0x00000000) 173

- 3.7.5.6. R_TWD Interval Value Register (Default Value: 0x00000000) 173
- 3.7.5.7. R_TWD Low Counter Compare Register (Default Value: 0x00000000) 174
- 3.7.5.8. R_TWD High Counter Compare Register (Default Value: 0x00000000)..... 174
- 3.7.5.9. Secure Storage NV-Counter Register (Default Value: 0x00000000)..... 174
- 3.7.5.10. Synchronize Data Counter Register 0 (Default Value: 0x00000000) 174
- 3.7.5.11. Synchronize Data Counter Register 1 (Default Value: 0x00000000) 174
- 3.7.5.12. Synchronize Data Counter Register 2 (Default Value: 0x00000000) 175
- 3.7.5.13. Synchronize Data Counter Register 3 (Default Value: 0x00000000) 175
- 3.8. RTC..... 176
 - 3.8.1. Overview 176
 - 3.8.2. RTC Register List 176
 - 3.8.3. RTC Register Description 177
 - 3.8.3.1. LOSC Control Register (Default Value: 0x00004000)..... 177
 - 3.8.3.2. LOSC Auto Switch Status Register (Default Value: 0x00000000) 178
 - 3.8.3.3. Internal OSC Clock Prescaler Register (Default Value: 0x0000000F)..... 178
 - 3.8.3.4. RTC YY-MM-DD Register (Default Value: 0x00000000)..... 179
 - 3.8.3.5. RTC HH-MM-SS Register (Default Value: 0x00000000)..... 179
 - 3.8.3.6. Alarm 0 Counter Register (Default Value: 0x00000000)..... 180
 - 3.8.3.7. Alarm 0 Current Value Register..... 180
 - 3.8.3.8. Alarm 0 Enable Register (Default Value: 0x00000000) 180
 - 3.8.3.9. Alarm 0 IRQ Enable Register (Default Value: 0x00000000) 181
 - 3.8.3.10. Alarm 0 IRQ Status Register (Default Value: 0x00000000) 181
 - 3.8.3.11. Alarm 1 Week HH-MM-SS Register (Default Value: 0x00000000) 181
 - 3.8.3.12. Alarm 1 Enable Register (Default Value: 0x00000000) 182

- 3.8.3.13. Alarm 1 IRQ Enable Register (Default Value: 0x00000000) 183
- 3.8.3.14. Alarm 1 IRQ Status Register (Default Value: 0x00000000) 183
- 3.8.3.15. Alarm Config Register (Default Value: 0x00000000)..... 184
- 3.8.3.16. LOSC Output Gating Register (Default Value: 0x00000000) 184
- 3.8.3.17. General Purpose Register (Default Value: 0x00000000)..... 184
- 3.8.3.18. GPL Hold Output Register (Default Value: 0x00000000) 184
- 3.8.3.19. VDD RTC Regulation Register (Default Value: 0x00000004) 186
- 3.8.3.20. IC Characteristic Register (Default Value: 0x00000000) 187
- 3.8.3.21. Crypt Configuration Register (Default Value: 0x00000000) 187
- 3.8.3.22. Crypt Key Register (Default Value: 0x00000000) 187
- 3.8.3.23. Crypt Enable Register (Default Value: 0x00000000) 187
- 3.9. High-speed Timer 188
 - 3.9.1. Overview 188
 - 3.9.2. Operation Principle 188
 - 3.9.2.1. HSTimer clock gating and software reset 188
 - 3.9.2.2. HSTimer reload bit..... 188
 - 3.9.3. HSTimer Block Diagram 189
 - 3.9.4. HSTimer Register List 189
 - 3.9.5. HSTimer Register Description 189
 - 3.9.5.1. HS Timer IRQ Enable Register (Default Value: 0x00000000) 189
 - 3.9.5.2. HS Timer IRQ Status Register (Default Value: 0x00000000) 190
 - 3.9.5.3. HS Timer Control Register (Default Value: 0x00000000)..... 190
 - 3.9.5.4. HS Timer Interval Value Lo Register 191
 - 3.9.5.5. HS Timer Interval Value Hi Register 191

3.9.5.6.	HS Timer Current Value Lo Register	192
3.9.5.7.	HS Timer Current Value Hi Register	192
3.9.6.	Programming Guidelines.....	192
3.10.	PWM	193
3.10.1.	Overview	193
3.10.2.	PWM Block Diagram	193
3.10.3.	PWM Register List	194
3.10.4.	PWM Register Description	194
3.10.4.1.	PWM Control Register(Default Value: 0x00000000).....	194
3.10.4.2.	PWM Channel 0 Period Register	195
3.11.	DMA.....	196
3.11.1.	Overview	196
3.11.2.	Functionalities Description	196
3.11.2.1.	Block Diagram	196
3.11.2.2.	DRQ Type and Corresponding Relation.....	197
3.11.2.3.	DMA Descriptor	197
3.11.3.	DMA Register List.....	198
3.11.4.	DMA Register Description.....	199
3.11.4.1.	DMA IRQ Enable Register (Default Value: 0x00000000).....	199
3.11.4.2.	DMA IRQ Pending Status Register0 (Default Value: 0x00000000)	201
3.11.4.3.	DMA Security Register (Default Value: 0x00000000)	203
3.11.4.4.	DMA Auto Gating Register (Default Value: 0x00000000)	204
3.11.4.5.	DMA Status Register (Default Value: 0x00000000).....	205
3.11.4.6.	DMA Channel Enable Register (Default Value: 0x00000000)	206

- 3.11.4.7. DMA Channel Pause Register (Default Value: 0x00000000) 206
- 3.11.4.8. DMA Channel Descriptor Address Register (Default Value: 0x00000000) 206
- 3.11.4.9. DMA Channel Configuration Register (Default Value: 0x00000000) 207
- 3.11.4.10. DMA Channel Current Source Address Register (Default Value: 0x00000000) 208
- 3.11.4.11. DMA Channel Current Destination Address Register (Default Value: 0x00000000) .. 208
- 3.11.4.12. DMA Channel Byte Counter Left Register (Default Value: 0x00000000) 208
- 3.11.4.13. DMA Channel Parameter Register (Default Value: 0x00000000) 208
- 3.11.4.14. DMA Mode Register (Default Value: 0x00000000)..... 209
- 3.11.4.15. DMA Former Descriptor Address Register (Default Value: 0x00000000) 209
- 3.11.4.16. DMA Package Number Register (Default Value: 0x00000000) 209
- 3.12. GIC..... 210
 - 3.12.1. Interrupt Source..... 210
- 3.13. Message Box 214
 - 3.13.1. Overview 214
 - 3.13.2. Functionalities Description 214
 - 3.13.2.1. Typical Applications..... 215
 - 3.13.2.2. Functional Block Diagram 216
 - 3.13.3. Operation Principle 216
 - 3.13.3.1. Message Queue Assignment..... 216
 - 3.13.3.2. Interrupt request 217
 - 3.13.4. Message Box Register List 217
 - 3.13.5. Message Box Register Description 218
 - 3.13.5.1. MSGBox Control Register 0(Default Value: 0x10101010) 218
 - 3.13.5.2. MSGBox Control Register 1(Default Value: 0x10101010) 219

- 3.13.5.3. MSGBox IRQ Enable Register u(Default Value: 0x00000000) 220
- 3.13.5.4. MSGBox IRQ Status Register u(Default Value: 0x0000AAAA) 222
- 3.13.5.5. MSGBox FIFO Status Register m(Default Value: 0x00000000)..... 223
- 3.13.5.6. MSGBox Message Status Register m(Default Value: 0x00000000)..... 223
- 3.13.5.7. MSGBox Message Queue Register (Default Value: 0x00000000) 224
- 3.14. Spinlock..... 225
 - 3.14.1. Overview 225
 - 3.14.2. Functionalities Description 226
 - 3.14.2.1. Typical Applications..... 226
 - 3.14.2.2. Functional Block Diagram 226
 - 3.14.3. Operation Principle 227
 - 3.14.3.1. Spinlock clock gating and software reset 227
 - 3.14.3.2. Take and free a spinlock 227
 - 3.14.4. Spinlock Register List..... 227
 - 3.14.5. Spinlock Register Description..... 228
 - 3.14.5.1. Spinlock System Status Register (Default Value: 0x10000000)..... 228
 - 3.14.5.2. Spinlock Register Status (Default Value: 0x00000000) 228
 - 3.14.5.3. Spinlock Lock Register N (N=0 to 31)(Default Value: 0x00000000) 228
 - 3.14.6. Programming Guidelines..... 229
- 3.15. Crypto Engine..... 230
 - 3.15.1. Overview 230
 - 3.15.2. Functionalities Description 230
 - 3.15.2.1. Block Diagram 230
 - 3.15.2.2. Crypto Engine with keysram 231

3.15.2.3.	Crypto Engine Task Descriptor	233
3.15.3.	Crypto Engine Register List	236
3.15.4.	Crypto Engine Register Description	237
3.15.4.1.	Crypto Engine Task Descriptor Queue Register(Default Value: 0x00000000)	237
3.15.4.2.	Crypto Engine Control Register(Default Value: 0x00000000).....	237
3.15.4.3.	Crypto Engine Interrupt Control Register(Default Value: 0x00000000)	237
3.15.4.4.	Crypto Engine Interrupt Status Register(Default Value: 0x00000000)	237
3.15.4.5.	Crypto Engine Task Load Register(Default Value: 0x00000000)	238
3.15.4.6.	Crypto Engine Task Status Register(Default Value: 0x00000000).....	238
3.15.4.7.	Crypto Engine Error Status Register(Default Value: 0x00000000).....	238
3.15.4.8.	Crypto Engine Current Source Address Register(Default Value: 0x00000000).....	239
3.15.4.9.	Crypto Engine Current Destination Address Register(Default Value: 0x00000000)	239
3.15.4.10.	Crypto Engine Throughput Register(Default Value: 0x00000000).....	239
3.15.5.	Crypto Engine Clock Requirement	239
3.16.	Secure Memory Controller	242
3.16.1.	Overview	242
3.16.2.	Functionalities Description	242
3.16.2.1.	DRM Block Diagram	243
3.16.2.2.	Master ID Table	243
3.16.2.3.	Region Size Table.....	244
3.16.2.4.	Security inversion is disabled.....	244
3.16.2.5.	Security inversion is enabled	245
3.16.3.	SMC Register List.....	245
3.16.4.	SMC Register Description.....	246

- 3.16.4.1. SMC Configuration Register(Default Value: 0x00001F0F) 246
- 3.16.4.2. SMC Action Register(Default Value: 0x00000001) 246
- 3.16.4.3. SMC Lockdown Range Register(Default Value: 0x00000000)..... 247
- 3.16.4.4. SMC Lockdown Select Register(Default Value: 0x00000000) 247
- 3.16.4.5. SMC Interrupt Status Register(Default Value: 0x00000000) 248
- 3.16.4.6. SMC Interrupt Clear Register(Default Value: 0x00000000) 248
- 3.16.4.7. SMC Master Bypass Register(Default Value: 0xFFFFFFFF) 248
- 3.16.4.8. SMC Master Secure Register(Default Value: 0x00000000)..... 249
- 3.16.4.9. SMC Fail Address Register(Default Value: 0x00000000)..... 249
- 3.16.4.10. SMC Fail Control Register(Default Value: 0x00000000) 249
- 3.16.4.11. SMC Fail ID Register(Default Value: 0x00001F00) 250
- 3.16.4.12. SMC Speculation Control Register(Default Value: 0x00000000) 250
- 3.16.4.13. SMC Security Inversion Enable Register(Default Value: 0x00000000) 251
- 3.16.4.14. SMC Master Attribute Register(Default Value: 0x00000000) 251
- 3.16.4.15. DRM Master Enable Register(Default Value: 0x00000000)..... 251
- 3.16.4.16. DRM Illegal Access Register(Default Value: 0x00000000) 252
- 3.16.4.17. DRM Start Address Register(Default Value: 0x00000000)..... 252
- 3.16.4.18. DRM End Address Register(Default Value: 0x00000000) 252
- 3.16.4.19. SMC Region Setup Low Register(Default Value: 0x00000000) 252
- 3.16.4.20. SMC Region Setup High Register(Default Value: 0x00000000) 253
- 3.16.4.21. SMC Region Attributes Register(Default Value: 0x00000000)..... 253
- 3.17. Secure Peripherals Controller 255
 - 3.17.1. Overview 255
 - 3.17.2. Functionalities Description 255

- 3.17.2.1. Peripherals Security Feature Table..... 255
- 3.17.2.2. SPC Configuration Table 256
- 3.17.3. SPC Register List 257
- 3.17.4. SPC Register Description 257
 - 3.17.4.1. SPC DECPOR0 Status Register(Default Value: 0x00000000) 257
 - 3.17.4.2. SPC DECPOR0 Set Register(Default Value: 0x00000000) 258
 - 3.17.4.3. SPC DECPOR0 Clear Register(Default Value: 0x00000000)..... 258
 - 3.17.4.4. SPC DECPOR1 Status Register(Default Value: 0x00000000) 258
 - 3.17.4.5. SPC DECPOR1 Set Register(Default Value: 0x00000000) 258
 - 3.17.4.6. SPC DECPOR1 Clear Register(Default Value: 0x00000000)..... 259
 - 3.17.4.7. SPC DECPOR2 Status Register(Default Value: 0x00000000) 259
 - 3.17.4.8. SPC DECPOR2 Set Register(Default Value: 0x00000000) 259
 - 3.17.4.9. SPC DECPOR2 Clear Register(Default Value: 0x00000000)..... 260
 - 3.17.4.10. SPC DECPOR3 Status Register(Default Value: 0x00000000) 260
 - 3.17.4.11. SPC DECPOR3 Set Register(Default Value: 0x00000000) 260
 - 3.17.4.12. SPC DECPOR3 Clear Register(Default Value: 0x00000000)..... 261
 - 3.17.4.13. SPC DECPOR4 Status Register(Default Value: 0x00000000) 261
 - 3.17.4.14. SPC DECPOR4 Set Register(Default Value: 0x00000000) 261
 - 3.17.4.15. SPC DECPOR4 Clear Register(Default Value: 0x00000000)..... 261
 - 3.17.4.16. SPC DECPOR5 Status Register(Default Value: 0x00000000) 262
 - 3.17.4.17. SPC DECPOR5 Set Register(Default Value: 0x00000000) 262
 - 3.17.4.18. SPC DECPOR5 Clear Register(Default Value: 0x00000000)..... 262
- 3.18. Thermal Sensor Controller 264
 - 3.18.1. Overview 264

- 3.18.2. Clock and Timing Requirements 264
- 3.18.3. Temperature Conversion Formula 265
- 3.18.4. Thermal Sensor Register List..... 265
- 3.18.5. Thermal Sensor Register Description..... 265
 - 3.18.5.1. THS Control Register0 (Default Value: 0x00000000)..... 265
 - 3.18.5.2. THS Control Register1 (Default Value: 0x00000000)..... 266
 - 3.18.5.3. ADC calibration Data Register (Default Value: 0x00000000) 266
 - 3.18.5.4. THS Control Register2 (Default Value: 0x00040000)..... 266
 - 3.18.5.5. THS Interrupt Control Register (Default Value: 0x00000000) 267
 - 3.18.5.6. THS status Register (Default Value: 0x00000000) 268
 - 3.18.5.7. Alarm threshold Control Register0 (Default Value: 0x05a00684)..... 269
 - 3.18.5.8. Alarm threshold Control Register1 (Default Value: 0x05a00684)..... 269
 - 3.18.5.9. Alarm threshold Control Register2 (Default Value: 0x05a00684)..... 270
 - 3.18.5.10. Shutdown threshold Control Register0 (Default Value: 0x04e90000) 270
 - 3.18.5.11. Shutdown threshold Control Register1 (Default Value: 0x04e90000) 270
 - 3.18.5.12. Shutdown threshold Control Register2 (Default Value: 0x04e90000) 270
 - 3.18.5.13. Average filter Control Register (Default Value: 0x00000001) 271
 - 3.18.5.14. Thermal Sensor 0&1 calibration Data Register (Default Value: 0x08000800) 271
 - 3.18.5.15. Thermal Sensor 2 calibration Data Register (Default Value: 0x00000800) 271
 - 3.18.5.16. THS0 Data Register (Default Value: 0x00000000) 272
 - 3.18.5.17. THS1 Data Register (Default Value: 0x00000000) 272
 - 3.18.5.18. THS2 Data Register (Default Value: 0x00000000) 272
- 3.19. KEYADC..... 273
 - 3.19.1. Overview 273

3.19.2.	Clock Source.....	273
3.19.3.	Operation Principle	273
3.19.4.	KEY_ADC Register List	274
3.19.5.	KEYADC Register Description	275
3.19.5.1.	KEYADC Control Register (Default Value: 0x01000168)	275
3.19.5.2.	KEYADC Interrupt Control Register (Default Value: 0x00000000).....	276
3.19.5.3.	KEYADC Interrupt Status Register (Default Value: 0x00000000).....	276
3.19.5.4.	KEYADC Data Register (Default Value: 0x00000000).....	277
3.20.	Audio Codec.....	278
3.20.1.	Overview	278
3.20.2.	Power and Signal Description	279
3.20.2.1.	Analog I/O Pins	279
3.20.2.2.	Filter/Reference	279
3.20.2.3.	Power/Ground	280
3.20.3.	Data Path Diagram	280
3.20.4.	Audio Codec Register List.....	280
3.20.5.	Audio Codec Register Description.....	286
3.20.5.1.	0x00 I2S_AP Control Register(Default Value: 0x00000000).....	286
3.20.5.2.	0x04 I2S_AP Format Register0(Default Value: 0x0000000C).....	287
3.20.5.3.	0x08 I2S_AP Format Register1(Default Value: 0x00004020)	288
3.20.5.4.	0x0C I2S_AP Interrupt Status Register(Default Value: 0x00000010)	289
3.20.5.5.	0x10 I2S_AP RX FIFO Register(Default Value: 0x00000000)	290
3.20.5.6.	0x14 I2S_AP FIFO Control Register(Default Value: 0x000400F0).....	290
3.20.5.7.	0x18 I2S_AP FIFO Status Register(Default Value: 0x10800000).....	291

3.20.5.8. 0x1C I2S_AP DMA&Interrupt Control Register(Default Value: 0x00000000) 292

3.20.5.9. 0x20 I2S_AP TX FIFO Register(Default Value: 0x00000000)..... 293

3.20.5.10. 0x24 I2S_AP Clock Divide Register(Default Value: 0x00000000) 293

3.20.5.11. 0x28 I2S_AP TX Counter Register(Default Value: 0x00000000)..... 294

3.20.5.12. 0x2C I2S_AP RX Counter Register(Default Value: 0x00000000) 294

3.20.5.13. 0x30 I2S_AP TX Channel Select Register(Default Value: 0x00000001) 295

3.20.5.14. 0x34 I2S_AP TX Channel Mapping Register(Default Value: 0x76543210) 295

3.20.5.15. 0x38 I2S_AP RX Channel Select Register(Default Value: 0x00000001)..... 296

3.20.5.16. 0x3C I2S_AP RX Channel Mapping Register(Default Value: 0x00003210) 296

3.20.5.17. 0x200 Codec Reset Register(Default Value: 0x00000101) 297

3.20.5.18. 0x20C System Clock Control Register(Default Value: 0x00000000)..... 297

3.20.5.19. 0x210 Module Clock Control Register(Default Value: 0x00000000)..... 298

3.20.5.20. 0x214 Module Reset Control Register(Default Value: 0x00000000) 299

3.20.5.21. 0x218 System Sample rate & SRC Configuration Register(Default Value: 0x00000000)
299

3.20.5.22. 0x21C System SRC Clock Source Select Register(Default Value: 0x00000000) 300

3.20.5.23. 0x220 System DVC Mode Select Register(Default Value: 0x00000000) 301

3.20.5.24. 0x240 AIF1 BCLK/LRCK Control Register(Default Value: 0x00000000) 301

3.20.5.25. 0x244 AIF1 ADCDAT Control Register(Default Value: 0x00000000)..... 302

3.20.5.26. 0x248 AIF1 DACDAT Control Register(Default Value: 0x00000000)..... 304

3.20.5.27. 0x24C AIF1 Digital Mixer Source Select Register(Default Value: 0x00000000)..... 305

3.20.5.28. 0x250 AIF1 Volume Control 1 Register(Default Value: 0x0000A0A0) 306

3.20.5.29. 0x254 AIF1 Volume Control 2 Register(Default Value: 0x0000A0A0) 307

3.20.5.30. 0x258 AIF1 Volume Control 3 Register(Default Value: 0x0000A0A0) 307

3.20.5.31.	0x25C AIF1 Volume Control 4 Register(Default Value: 0x0000A0A0).....	308
3.20.5.32.	0x260 AIF1 Digital Mixer Gain Control Register(Default Value: 0x00000000)	309
3.20.5.33.	0x264 AIF1 Receiver Data Discarding Control Register(Default Value: 0x00000000) 309	
3.20.5.34.	0x280 AIF2 BCLK/LRCK Control Register(Default Value: 0x00000000)	310
3.20.5.35.	0x284 AIF2 ADCDAT Control Register(Default Value: 0x00000000).....	311
3.20.5.36.	0x288 AIF2 DACDAT Control Register(Default Value: 0x00000000).....	312
3.20.5.37.	0x28C AIF2 Digital Mixer Source Select Register(Default Value: 0x00000000).....	313
3.20.5.38.	0x290 AIF2 Volume Control 1 Register(Default Value: 0x0000A0A0)	313
3.20.5.39.	0x298 AIF2 Volume Control 2 Register(Default Value: 0x0000A0A0)	314
3.20.5.40.	0x2A0 AIF2 Digital Mixer Gain Control Register(Default Value: 0x00000000).....	315
3.20.5.41.	0x2A4 AIF2 Receiver Data Discarding Control Register(Default Value: 0x00000000) 315	
3.20.5.42.	0x2C0 AIF3 BCLK/LRCK Control Register(Default Value: 0x00000000)	315
3.20.5.43.	0x2C4 AIF3 ADCDAT Control Register(Default Value: 0x00000000)	316
3.20.5.44.	0x2C8 AIF3 DACDAT Control Register(Default Value: 0x00000000).....	316
3.20.5.45.	0x2CC AIF3 Signal Path Control Register(Default Value: 0x00000000)	317
3.20.5.46.	0x2E4 AIF3 Receiver Data Discarding Control Register(Default Value: 0x00000000) 318	
3.20.5.47.	0x300 ADC Digital Control Register(Default Value: 0x00000000).....	318
3.20.5.48.	0x304 ADC Volume Control Register(Default Value: 0x0000A0A0)	319
3.20.5.49.	0x308 ADC Debug Control Register(Default Value: 0x00000000).....	319
3.20.5.50.	0x310 HMIC Control 1 Register(Default Value: 0x00000020)	321
3.20.5.51.	0x314 HMIC Control 2 Register(Default Value: 0x00000000)	322
3.20.5.52.	0x318 HMIC Status Register(Default Value: 0x00000000).....	322
3.20.5.53.	0x320 DAC Digital Control Register(Default Value: 0x00000000)	323
3.20.5.54.	0x324 DAC Volume Control Register(Default Value: 0x0000A0A0)	324

3.20.5.55. 0x328 DAC Debug Control Register(Default Value: 0x00000000)..... 325

3.20.5.56. 0x330 DAC Digital Mixer Source Select Register(Default Value: 0x00000000) 325

3.20.5.57. 0x334 DAC Digital Mixer Gain Control Register(Default Value: 0x00000000) 326

3.20.5.58. 0x400 ADC DAP Left Status Register(Default Value: 0x00000000) 326

3.20.5.59. 0x404 ADC DAP Right Status Register(Default Value: 0x00000000) 327

3.20.5.60. 0x408 ADC DAP Left Channel Control Register(Default Value: 0x00000000) 327

3.20.5.61. 0x40C ADC DAP Right Channel Control Register(Default Value: 0x00000000) 328

3.20.5.62. 0x410 ADC DAP Left Target Level Register(Default Value: 0x00002C28) 328

3.20.5.63. 0x414 ADC DAP Right Target Level Register(Default Value: 0x00002C28) 329

3.20.5.64. 0x418 ADC DAP Left High Average Coef Register(Default Value: 0x00000005)..... 329

3.20.5.65. 0x41C ADC DAP Left Low Average Coef Register(Default Value: 0x00001EB8) 329

3.20.5.66. 0x420 ADC DAP Right High Average Coef Register(Default Value: 0x00000005) 329

3.20.5.67. 0x424 ADC DAP Right Low Average Coef Register(Default Value: 0x00001EB8) 330

3.20.5.68. 0x428 ADC DAP Left Decay Time Register(Default Value: 0x0000001F)..... 330

3.20.5.69. 0x42C ADC DAP Left Attack Time Register(Default Value: 0x00000000)..... 330

3.20.5.70. 0x430 ADC DAP Right Decay Time Register(Default Value: 0x0000001F) 330

3.20.5.71. 0x434 ADC DAP Right Attack Time Register(Default Value: 0x00000000)..... 331

3.20.5.72. 0x438 ADC DAP Noise Threshold Register(Default Value: 0x00001E1E) 331

3.20.5.73. 0x43C ADC DAP Left Input Signal High Average Coef Register(Default Value: 0x00000005) 332

3.20.5.74. 0x440 ADC DAP Left Input Signal Low Average Coef Register(Default Value: 0x00001EB8) 332

3.20.5.75. 0x444 ADC DAP Right Input Signal High Average Coef Register(Default Value: 0x00000005) 332

3.20.5.76. 0x448 ADC DAP Right Input Signal Low Average Coef Register(Default Value: 0x00001EB8) 332

3.20.5.77. 0x44C ADC DAP High HPF Coef Register(Default Value: 0x000000FF)..... 333

3.20.5.78. 0x450 ADC DAP Low HPF Coef Register(Default Value: 0x0000FAC1) 333

3.20.5.79. 0x454 ADC DAP Optimum Register(Default Value: 0x00000000)..... 333

3.20.5.80. 0x480 DAC DAP Control Register(Default Value: 0x00000000) 334

3.20.5.81. 0x4D0 AGC Enable Register(Default Value: 0x00000000)..... 334

3.20.5.82. 0x4D4 DRC Enable Register(Default Value: 0x00000000)..... 335

3.20.5.83. 0x4D8 SRC Bist Control Register(Default Value: 0x00000000)..... 336

3.20.5.84. 0x4DC SRC Bist Status Register(Default Value: 0x00000202) 337

3.20.5.85. 0x4E0 SRC1 Control 1 Register(Default Value: 0x00000000)..... 338

3.20.5.86. 0x4E4 SRC1 Control 2 Register(Default Value: 0x00000000)..... 338

3.20.5.87. 0x4E8 SRC1 Control 3 Register(Default Value: 0x00000040)..... 338

3.20.5.88. 0x4EC SRC1 Control 4 Register(Default Value: 0x00000000)..... 338

3.20.5.89. 0x4F0 SRC2 Control 1 Register(Default Value: 0x00000000) 339

3.20.5.90. 0x4F4 SRC2 Control 2 Register(Default Value: 0x00000000) 339

3.20.5.91. 0x4F8 SRC2 Control 3 Register(Default Value: 0x00000040) 339

3.20.5.92. 0x4FC SRC2 Control 4 Register(Default Value: 0x00000000) 339

3.20.5.93. 0x600 DRC0 High HPF Coef Register(Default Value: 0x000000FF)..... 340

3.20.5.94. 0x604 DRC0 Low HPF Coef Register(Default Value: 0x0000FAC1) 340

3.20.5.95. 0x608 DRC0 Control Register(Default Value: 0x00000080) 340

3.20.5.96. 0x60C DRC0 Left Peak Filter High Attack Time Coef Register(Default Value: 0x0000000B)..... 341

3.20.5.97. 0x610 DRC0 Left Peak Filter Low Attack Time Coef Register(Default Value: 0x000077BF) 342

3.20.5.98. 0x614 DRC0 Right Peak Filter High Attack Time Coef Register(Default Value: 0x0000000B)..... 342

3.20.5.99. 0x618 DRC0 Peak Filter Low Attack Time Coef Register(Default Value: 0x000077BF)342

3.20.5.100. 0x61C DRC0 Left Peak Filter High Release Time Coef Register(Default Value: 0x000000FF) 342

3.20.5.101. 0x620 DRC0 Left Peak Filter Low Release Time Coef Register(Default Value: 0x0000E1F8) 342

3.20.5.102. 0x624 DRC0 Right Peak filter High Release Time Coef Register(Default Value: 0x000000FF) 343

3.20.5.103. 0x628 DRC0 Right Peak filter Low Release Time Coef Register(Default Value: 0x0000E1F8) 343

3.20.5.104. 0x62C DRC0 Left RMS Filter High Coef Register(Default Value: 0x00000001)..... 343

3.20.5.105. 0x630 DRC0 Left RMS Filter Low Coef Register(Default Value: 0x00002BAF) 343

3.20.5.106. 0x634 DRC0 Right RMS Filter High Coef Register(Default Value: 0x00000001)..... 343

3.20.5.107. 0x638 DRC0 Right RMS Filter Low Coef Register(Default Value: 0x00002BAF) 344

3.20.5.108. 0x63C DRC0 Compressor Theshold High Setting Register(Default Value: 0x000006A4) 344

3.20.5.109. 0x640 DRC0 Compressor Theshold Low Setting Register(Default Value: 0x0000D3C0) 344

3.20.5.110. 0x644 DRC0 Compressor Slope High Setting Register(Default Value: 0x00000080) 344

3.20.5.111. 0x648 DRC0 Compressor Slope Low Setting Register(Default Value: 0x00000000) 344

3.20.5.112. 0x64C DRC0 Compressor High Output at Compressor Threshold Register(Default Value: 0x0000F95B) 345

3.20.5.113. 0x650 DRC0 Compressor Low Output at Compressor Threshold Register(Default Value: 0x00002C3F) 345

3.20.5.114. 0x654 DRC0 Limiter Theshold High Setting Register(Default Value: 0x000001A9) . 345

3.20.5.115. 0x658 DRC0 Limiter Theshold Low Setting Register(Default Value: 0x000034F0) .. 345

3.20.5.116. 0x65C DRC0 Limiter Slope High Setting Register(Default Value: 0x00000005) 345

3.20.5.117. 0x660 DRC0 Limiter Slope Low Setting Register(Default Value: 0x00001EB8) 346

- 3.20.5.118. 0x664 DRC0 Limiter High Output at Limiter Threshold Register(Default Value: 0x0000FBD8) 346
- 3.20.5.119. 0x668 DRC0 Limiter Low Output at Limiter Threshold Register(Default Value: 0x0000FBA7) 346
- 3.20.5.120. 0x66C DRC0 Expander Theshold High Setting Register(Default Value: 0x00000BA0)346
- 3.20.5.121. 0x670 DRC0 Expander Theshold Low Setting Register(Default Value: 0x00007291)346
- 3.20.5.122. 0x674 DRC0 Expander Slope High Setting Register(Default Value: 0x00000500).... 347
- 3.20.5.123. 0x678 DRC0 Expander Slope Low Setting Register(Default Value: 0x00000000) 347
- 3.20.5.124. 0x67C DRC0 Expander High Output at Expander Threshold Register(Default Value: 0x0000F45F) 347
- 3.20.5.125. 0x680 DRC0 Expander Low Output at Expander Threshold Register(Default Value: 0x00008D6E) 347
- 3.20.5.126. 0x684 DRC0 Linear Slope High Setting Register(Default Value: 0x00000100)..... 348
- 3.20.5.127. 0x688 DRC0 Linear Slope Low Setting Register(Default Value: 0x00000000)..... 348
- 3.20.5.128. 0x68C DRC0 Smooth filter Gain High Attack Time Coef Register(Default Value: 0x00000002) 348
- 3.20.5.129. 0x690 DRC0 Smooth filter Gain Low Attack Time Coef Register(Default Value: 0x00005600) 348
- 3.20.5.130. 0x694 DRC0 Smooth filter Gain High Release Time Coef Register(Default Value: 0x00000000) 348
- 3.20.5.131. 0x698 DRC0 Smooth filter Gain Low Release Time Coef Register(Default Value: 0x00000F04) 349
- 3.20.5.132. 0x69C DRC0 MAX Gain High Setting Register(Default Value: 0x0000FE56)..... 349
- 3.20.5.133. 0x6A0 DRC0 MAX Gain Low Setting Register(Default Value: 0x0000CB0F) 349
- 3.20.5.134. 0x6A4 DRC0 MIN Gain High Setting Register(Default Value: 0x0000F95B) 349
- 3.20.5.135. 0x6A8 DRC0 MIN Gain Low Setting Register(Default Value: 0x00002C3F)..... 349
- 3.20.5.136. 0x6AC DRC0 Expander Smooth Time High Coef Register(Default Value: 0x00000000) 350

3.20.5.137. 0x6B0 DRC0 Expander Smooth Time Low Coef Register(Default Value: 0x0000640C) 350

3.20.5.138. 0x6B4 DRC0 Optimum Register(Default Value: 0x00000000)..... 350

3.20.5.139. 0x6B8 DRC0 HPF Gain High Coef Register(Default Value: 0x00000100)..... 351

3.20.5.140. 0x6BC DRC0 HPF Gain Low Coef Register(Default Value: 0x00000000) 351

3.20.5.141. 0x700 DRC1 High HPF Coef Register(Default Value: 0x000000FF)..... 351

3.20.5.142. 0x704 DRC1 Low HPF Coef Register(Default Value: 0x0000FAC1) 352

3.20.5.143. 0x708 DRC1 Control Register(Default Value: 0x00000080) 352

3.20.5.144. 0x70C DRC1 Left Peak Filter High Attack Time Coef Register(Default Value: 0x0000000B) 353

3.20.5.145. 0x710 DRC1 Left Peak Filter Low Attack Time Coef Register(Default Value: 0x000077BF) 353

3.20.5.146. 0x714 DRC1 Right Peak Filter High Attack Time Coef Register(Default Value: 0x0000000B) 354

3.20.5.147. 0x718 DRC1 Peak Filter Low Attack Time Coef Register(Default Value: 0x000077BF)354

3.20.5.148. 0x71C DRC1 Left Peak Filter High Release Time Coef Register(Default Value: 0x000000FF) 354

3.20.5.149. 0x720 DRC1 Left Peak Filter Low Release Time Coef Register(Default Value: 0x0000E1F8) 354

3.20.5.150. 0x724 DRC1 Right Peak filter High Release Time Coef Register(Default Value: 0x000000FF) 354

3.20.5.151. 0x728 DRC1 Right Peak filter Low Release Time Coef Register(Default Value: 0x0000E1F8) 355

3.20.5.152. 0x72C DRC Left RMS Filter High Coef Register(Default Value: 0x00000001)..... 355

3.20.5.153. 0x730 DRC1 Left RMS Filter Low Coef Register(Default Value: 0x00002BAF) 355

3.20.5.154. 0x734 DRC1 Right RMS Filter High Coef Register(Default Value: 0x00000001)..... 355

3.20.5.155. 0x738 DRC1 Right RMS Filter Low Coef Register(Default Value: 0x00002BAF) 355

3.20.5.156. 0x73C DRC1 Compressor Theshold High Setting Register(Default Value: 0x000006A4) 356

3.20.5.157. 0x740 DRC1 Compressor Slope High Setting Register(Default Value: 0x0000D3D0)356

3.20.5.158. 0x744 DRC1 Compressor Slope High Setting Register(Default Value: 0x00000080) 356

3.20.5.159. 0x748 DRC1 Compressor Slope Low Setting Register(Default Value: 0x00000000) 356

3.20.5.160. 0x74C DRC1 Compressor High Output at Compressor Threshold Register(Default Value: 0x0000F95B) 356

3.20.5.161. 0x750 DRC1 Compressor Low Output at Compressor Threshold Register(Default Value: 0x00002C3F) 357

3.20.5.162. 0x754 DRC1 Limiter Theshold High Setting Register(Default Value: 0x000001A9) . 357

3.20.5.163. 0x758 DRC1 Limiter Theshold Low Setting Register(Default Value: 0x000034F0) .. 357

3.20.5.164. 0x75C DRC1 Limiter Slope High Setting Register(Default Value: 0x00000005) 357

3.20.5.165. 0x760 DRC1 Limiter Slope Low Setting Register(Default Value: 0x00001EB8) 357

3.20.5.166. 0x764 DRC1 Limiter High Output at Limiter Threshold Register(Default Value: 0x0000FBD8) 358

3.20.5.167. 0x768 DRC1 Limiter Low Output at Limiter Threshold Register(Default Value: 0x0000FBA7) 358

3.20.5.168. 0x76C DRC1 Expander Theshold High Setting Register(Default Value: 0x00000BA0)358

3.20.5.169. 0x770 DRC1 Expander Theshold Low Setting Register(Default Value: 0x00007291)358

3.20.5.170. 0x774 DRC1 Expander Slope High Setting Register(Default Value: 0x00000500).... 358

3.20.5.171. 0x778 DRC1 Expander Slope Low Setting Register(Default Value: 0x00000000) 359

3.20.5.172. 0x77C DRC1 Expander High Output at Expander Threshold Register(Default Value: 0x0000F45F) 359

3.20.5.173. 0x780 DRC1 Expander Low Output at Expander Threshold Register(Default Value: 0x00008D6E) 359

3.20.5.174. 0x784 DRC1 Linear Slope High Setting Register(Default Value: 0x00000100) 359

3.20.5.175. 0x788 DRC1 Linear Slope Low Setting Register(Default Value: 0x00000000)..... 360

3.20.5.176. 0x78C DRC1 Smooth filter Gain High Attack Time Coef Register(Default Value: 0x00000002) 360

3.20.5.177. 0x790 DRC1 Smooth filter Gain Low Attack Time Coef Register(Default Value: 0x00005600) 360

3.20.5.178. 0x794 DRC1 Smooth filter Gain High Release Time Coef Register(Default Value: 0x00000000) 360

3.20.5.179. 0x798 DRC1 Smooth filter Gain Low Release Time Coef Register(Default Value: 0x00000F04) 360

3.20.5.180. 0x79C DRC1 MAX Gain High Setting Register(Default Value: 0x0000FE56) 361

3.20.5.181. 0x7A0 DRC1 MAX Gain Low Setting Register(Default Value: 0x0000CB0F) 361

3.20.5.182. 0x7A4 DRC1 MIN Gain High Setting Register(Default Value: 0x0000F95B) 361

3.20.5.183. 0x7A8 DRC1 MIN Gain Low Setting Register(Default Value: 0x00002C3F) 361

3.20.5.184. 0x7AC DRC1 Expander Smooth Time High Coef Register(Default Value: 0x00000000) 361

3.20.5.185. 0x7B0 DRC1 Expander Smooth Time Low Coef Register(Default Value: 0x0000640C) 362

3.20.5.186. 0x7B8 DRC1 HPF Gain High Coef Register(Default Value: 0x00000100) 362

3.20.5.187. 0x7BC DRC1 HPF Gain Low Coef Register(Default Value: 0x00000000) 362

3.20.5.188. AC_PR Configuration Register 362

3.20.5.189. 0x00 Headphone Amplifier Control Register(Default Value: 0x00) 363

3.20.5.190. 0x01 Output Left Mixer Control Register(Default Value: 0x00) 363

3.20.5.191. 0x02 Output Right Mixer Control Register(Default Value: 0x00) 363

3.20.5.192. 0x03 Earpiece Control Register 0 (Default Value: 0x00) 364

3.20.5.193. 0x04 Earpiece Control Register 1 (Default Value: 0x00) 364

3.20.5.194. 0x05 LINEOUT Control Register 0 (Default Value: 0x00) 365

3.20.5.195. 0x06 LINEOUT Control Register 1 (Default Value: 0x00) 365

3.20.5.196. 0x07 MIC1 Control Register (Default Value: 0x34) 365

3.20.5.197. 0x08 MIC2 Control Register (Default Value: 0x11) 366

3.20.5.198. 0x09 Linein Control Register (Default Value: 0x03) 366

3.20.5.199. 0x0A Mixer and DAC Control Register (Default Value: 0x00)..... 366

3.20.5.200. 0x0B Left ADC Mixer Control Register (Default Value: 0x00)..... 367

3.20.5.201. 0x0C Right ADC Mixer Control Register (Default Value: 0x00)..... 368

3.20.5.202. 0x0D ADC Control Register (Default Value: 0x03)..... 368

3.20.5.203. 0x0E Headset Microphone Bias Control Register (Default Value: 0x21)..... 368

3.20.5.204. 0x0F Analog Performance Tuning Register (Default Value: 0xD6) 369

3.20.5.205. 0x10 OP BIAS Control Register0 (Default Value: 0x55) 369

3.20.5.206. 0x11 OP BIAS Control Register1 (Default Value: 0x55) 370

3.20.5.207. 0x12 USB Bias & Volume Change Control Register (Default Value: 0x02) 370

3.20.5.208. 0x13 Bias Calibration Data Register (Default Value: 0x00)..... 370

3.20.5.209. 0x14 Bias Calibration Set Data Register (Default Value: 0x20) 371

3.20.5.210. 0x15 Bias & DA16 Calibration Control Register (Default Value: 0x00)..... 371

3.20.5.211. 0x16 Headphone PA Control Register (Default Value: 0xF1)..... 371

3.20.5.212. 0x17 Headphone Calibration Control Register (Default Value: 0x04)..... 372

3.20.5.213. 0x18 Right Headphone Calibration DAT Register (Default Value: 0x00) 373

3.20.5.214. 0x19 Right Headphone Calibration Setting Register (Default Value: 0x80) 373

3.20.5.215. 0x1A Left Headphone Calibration DAT Register (Default Value: 0x00) 373

3.20.5.216. 0x1B Left Headphone Calibration Setting Register (Default Value: 0x80) 373

3.20.5.217. 0x1C Mic detect Control Register (Default Value: 0x40)..... 373

3.20.5.218. 0x1D Jack & Mic detect Control Register (Default Value: 0x00) 374

3.20.5.219. 0x1E Phone Output Register (Default Value: 0x60) 375

3.20.5.220. 0x1F Phone Input Register (Default Value: 0x34) 375

- 3.21. Port Controller(CPUx-PORT)..... 376
 - 3.21.1. Port Controller Register List 376
 - 3.21.2. Port Controller Register Description 377
 - 3.21.2.1. PB Configure Register 0 (Default Value: 0x77777777)..... 377
 - 3.21.2.2. PB Configure Register 1 (Default Value: 0x00000077)..... 378
 - 3.21.2.3. PB Configure Register 2 (Default Value: 0x00000000)..... 378
 - 3.21.2.4. PB Configure Register 3 (Default Value: 0x00000000)..... 378
 - 3.21.2.5. PB Data Register (Default Value: 0x00000000)..... 379
 - 3.21.2.6. PB Multi-Driving Register 0 (Default Value: 0x00055555) 379
 - 3.21.2.7. PB Multi-Driving Register 1 (Default Value: 0x00000000) 379
 - 3.21.2.8. PB PULL Register 0 (Default Value: 0x00000000)..... 379
 - 3.21.2.9. PB PULL Register 1 (Default Value: 0x00000000)..... 380
 - 3.21.2.10. PC Configure Register 0 (Default Value: 0x77777777)..... 380
 - 3.21.2.11. PC Configure Register 1 (Default Value: 0x77777777)..... 381
 - 3.21.2.12. PC Configure Register 2 (Default Value: 0x00000777)..... 382
 - 3.21.2.13. PC Configure Register 3 (Default Value: 0x00000000)..... 383
 - 3.21.2.14. PC Data Register (Default Value: 0x00000000)..... 383
 - 3.21.2.15. PC Multi-Driving Register 0 (Default Value: 0x55555555) 383
 - 3.21.2.16. PC Multi-Driving Register 1 (Default Value: 0x00000015) 383
 - 3.21.2.17. PC PULL Register 0 (Default Value: 0x00005140)..... 384
 - 3.21.2.18. PC PULL Register 1 (Default Value: 0x00000014)..... 384
 - 3.21.2.19. PD Configure Register 0 (Default Value: 0x77777777) 384
 - 3.21.2.20. PD Configure Register 1 (Default Value: 0x77777777) 385
 - 3.21.2.21. PD Configure Register 2 (Default Value: 0x77777777) 387

3.21.2.22.	PD Configure Register 3 (Default Value: 0x00000007)	388
3.21.2.23.	PD Data Register (Default Value: 0x00000000).....	388
3.21.2.24.	PD Multi-Driving Register 0 (Default Value: 0x55555555).....	388
3.21.2.25.	PD Multi-Driving Register 1 (Default Value: 0x00015555).....	389
3.21.2.26.	PD PULL Register 0 (Default Value: 0x00000000)	389
3.21.2.27.	PD PULL Register 1 (Default Value: 0x00000000)	389
3.21.2.28.	PE Configure Register 0 (Default Value: 0x77777777)	389
3.21.2.29.	PE Configure Register 1 (Default Value: 0x77777777)	391
3.21.2.30.	PE Configure Register 2 (Default Value: 0x00000077)	392
3.21.2.31.	PE Configure Register 3 (Default Value: 0x00000000)	392
3.21.2.32.	PE Data Register (Default Value: 0x00000000)	392
3.21.2.33.	PE Multi-Driving Register 0 (Default Value: 0x55555555)	393
3.21.2.34.	PE Multi-Driving Register 1 (Default Value: 0x00000005)	393
3.21.2.35.	PE PULL Register 0 (Default Value: 0x00000000).....	393
3.21.2.36.	PE PULL Register 1 (Default Value: 0x00000000).....	393
3.21.2.37.	PF Configure Register 0 (Default Value: 0x07777777)	394
3.21.2.38.	PF Configure Register 1 (Default Value: 0x00000000)	395
3.21.2.39.	PF Configure Register 2(Default Value: 0x00000000)	395
3.21.2.40.	PF Configure Register 3(Default Value: 0x00000000)	395
3.21.2.41.	PF Data Register (Default Value: 0x00000000)	395
3.21.2.42.	PF Multi-Driving Register 0 (Default Value: 0x00001555)	396
3.21.2.43.	PF Multi-Driving Register 1 (Default Value: 0x00000000)	396
3.21.2.44.	PF PULL Register 0 (Default Value: 0x00000000).....	396
3.21.2.45.	PF PULL Register 1 (Default Value: 0x00000000).....	396

3.21.2.46. PG Configure Register 0 (Default Value: 0x77777777) 396

3.21.2.47. PG Configure Register 1 (Default Value: 0x00777777) 398

3.21.2.48. PG Configure Register 2 (Default Value: 0x00000000) 399

3.21.2.49. PG Configure Register 3 (Default Value: 0x00000000) 399

3.21.2.50. PG Data Register (Default Value: 0x00000000)..... 399

3.21.2.51. PG Multi-Driving Register 0 (Default Value: 0x05555555)..... 399

3.21.2.52. PG Multi-Driving Register 1 (Default Value: 0x00000000)..... 400

3.21.2.53. PG PULL Register 0 (Default Value: 0x00000000) 400

3.21.2.54. PG PULL Register 1 (Default Value: 0x00000000) 400

3.21.2.55. PH Configure Register 0 (Default Value: 0x77777777) 400

3.21.2.56. PH Configure Register 1 (Default Value: 0x00007777) 401

3.21.2.57. PH Configure Register 2 (Default Value: 0x00000000) 402

3.21.2.58. PH Configure Register 3 (Default Value: 0x00000000) 402

3.21.2.59. PH Data Register (Default Value: 0x00000000)..... 402

3.21.2.60. PH Multi-Driving Register 0 (Default Value: 0x00555555)..... 403

3.21.2.61. PH Multi-Driving Register 1 (Default Value: 0x00000000)..... 403

3.21.2.62. PH PULL Register 0 (Default Value: 0x00000000) 403

3.21.2.63. PH PULL Register 1 (Default Value: 0x00000000) 403

3.21.2.64. PB External Interrupt Configure Register 0 (Default Value: 0x00000000) 404

3.21.2.65. PB External Interrupt Configure Register 1 (Default Value: 0x00000000) 404

3.21.2.66. PB External Interrupt Configure Register 2 (Default Value: 0x00000000) 404

3.21.2.67. PB External Interrupt Configure Register 3 (Default Value: 0x00000000) 404

3.21.2.68. PB External Interrupt Control Register (Default Value: 0x00000000)..... 405

3.21.2.69. PB External Interrupt Status Register (Default Value: 0x00000000)..... 405

- 3.21.2.70. PB External Interrupt Debounce Register (Default Value: 0x00000000) 405
- 3.21.2.71. PG External Interrupt Configure Register 0 (Default Value: 0x00000000)..... 406
- 3.21.2.72. PG External Interrupt Configure Register 1 (Default Value: 0x00000000)..... 406
- 3.21.2.73. PG External Interrupt Configure Register 2 (Default Value: 0x00000000)..... 406
- 3.21.2.74. PG External Interrupt Configure Register 3 (Default Value: 0x00000000)..... 406
- 3.21.2.75. PG External Interrupt Control Register (Default Value: 0x00000000) 407
- 3.21.2.76. PG External Interrupt Status Register (Default Value: 0x00000000) 407
- 3.21.2.77. PG External Interrupt Debounce Register (Default Value: 0x00000000)..... 407
- 3.21.2.78. PH External Interrupt Configure Register 0 (Default Value: 0x00000000)..... 407
- 3.21.2.79. PH External Interrupt Configure Register 1 (Default Value: 0x00000000)..... 408
- 3.21.2.80. PH External Interrupt Configure Register2 (Default Value: 0x00000000)..... 408
- 3.21.2.81. PH External Interrupt Configure Register3 (Default Value: 0x00000000)..... 408
- 3.21.2.82. PH External Interrupt Control Register (Default Value: 0x00000000) 408
- 3.21.2.83. PH External Interrupt Status Register (Default Value: 0x00000000) 409
- 3.21.2.84. PH External Interrupt Debounce Register (Default Value: 0x00000000)..... 409
- 3.22. Port Controller(CPUs-PORT)..... 410
 - 3.22.1. Port Controller Register List 410
 - 3.22.2. Port Controller Register Description 410
 - 3.22.2.1. PL Configure Register 0 (Default Value: 0x77777777) 410
 - 3.22.2.2. PL Configure Register 1 (Default Value: 0x00077777) 412
 - 3.22.2.3. PL Configure Register 2 (Default Value: 0x00000000) 413
 - 3.22.2.4. PL Configure Register 3 (Default Value: 0x00000000) 413
 - 3.22.2.5. PL Data Register (Default Value: 0x00000000) 413
 - 3.22.2.6. PL Multi-Driving Register 0 (Default Value: 0x01555555)..... 413

3.22.2.7.	PL Multi-Driving Register 1 (Default Value: 0x00000000).....	413
3.22.2.8.	PL PULL Register 0 (Default Value: 0x00000005)	414
3.22.2.9.	PL PULL Register 1 (Default Value: 0x00000000)	414
3.22.2.10.	PL External Interrupt Configure Register 0 (Default Value: 0x00000000).....	414
3.22.2.11.	PL External Interrupt Configure Register 1 (Default Value: 0x00000000).....	414
3.22.2.12.	PL External Interrupt Configure Register 2 (Default Value: 0x00000000).....	415
3.22.2.13.	PL External Interrupt Configure Register 3 (Default Value: 0x00000000).....	415
3.22.2.14.	PL External Interrupt Control Register (Default Value: 0x00000000)	415
3.22.2.15.	PL External Interrupt Status Register (Default Value: 0x00000000)	415
3.22.2.16.	PL External Interrupt Debounce Register (Default Value: 0x00000000).....	416
Chapter 4	Memory	417
4.1.	SDRAM	417
4.1.1.	Overview	417
4.2.	NAND Flash Controller(NDFC).....	418
4.2.1.	Overview	418
4.2.2.	Block Diagram	419
4.2.3.	NDFC Timing Diagram.....	419
4.2.4.	NDFC Operation Guide.....	426
4.2.5.	NDFC Register List	427
4.2.6.	NDFC Register Description	428
4.2.6.1.	NDFC Control Register(Default Value: 0x00000000)	428
4.2.6.2.	NDFC Status Register(Default Value: 0x00000000)	430
4.2.6.3.	NDFC Interrupt and DMA Enable Register(Default Value: 0x00000000).....	431
4.2.6.4.	NDFC Timing Control Register(Default Value: 0x00000000)	432

4.2.6.5.	NDFC Timing Configure Register(Default Value: 0x00000095)	432
4.2.6.6.	NDFC Address Low Word Register(Default Value: 0x00000000)	434
4.2.6.7.	NDFC Address High Word Register(Default Value: 0x00000000)	434
4.2.6.8.	NDFC Data Block Number Register(Default Value: 0x00000000)	434
4.2.6.9.	NDFC Data Counter Register(Default Value: 0x00000000).....	435
4.2.6.10.	NDFC Command IO Register(Default Value: 0x00000000)	435
4.2.6.11.	NDFC Command Set Register 0(Default Value: 0x00E00530).....	437
4.2.6.12.	NDFC Command Set Register 1(Default Value: 0x70008510).....	437
4.2.6.13.	NDFC IO Data Register(Default Value: 0x00000000)	438
4.2.6.14.	NDFC ECC Control Register(Default Value: 0x4a800008)	438
4.2.6.15.	NDFC ECC Status Register(Default Value: 0x00000000)	439
4.2.6.16.	NDFC Enhanced Feature Register(Default Value: 0x00000000)	439
4.2.6.17.	NDFC Error Counter Register 0(Default Value: 0x00000000)	440
4.2.6.18.	NDFC Error Counter Register 1(Default Value: 0x00000000)	440
4.2.6.19.	NDFC Error Counter Register 2(Default Value: 0x00000000)	440
4.2.6.20.	NDFC Error Counter Register 3(Default Value: 0x00000000)	441
4.2.6.21.	NDFC User Data Register [n](Default Value: 0xffffffff).....	441
4.2.6.22.	NDFC EFNAND STATUS Register(Default Value: 0x00000000).....	441
4.2.6.23.	NDFC Spare Area Register(Default Value: 0x00000400).....	442
4.2.6.24.	NDFC Pattern ID Register(Default Value: 0x00000000)	442
4.2.6.25.	NDFC Read Data Status Control Register(Default Value: 0x01000000).....	442
4.2.6.26.	NDFC Read Data Status Register 0(Default Value: 0x00000000).....	443
4.2.6.27.	NDFC Read Data Status Register 1(Default Value: 0x00000000).....	443
4.2.6.28.	NDFC MBUS DMA Address Register(Default Value: 0x00000000).....	443

- 4.2.6.29. NDFC MBUS DMA Byte Counter Register(Default Value: 0x00000000) 443
- 4.2.6.30. NDFC Normal DMA Mode Control Register(Default Value: 0x000000A5)..... 443
- 4.3. SD-MMC Host Controller 444
 - 4.3.1. Overview 444
 - 4.3.2. Block Diagram 444
 - 4.3.3. SMHC Controller Timing Diagram 445
 - 4.3.4. SMHC Operation Description 445
 - 4.3.4.1. External Signal List 445
 - 4.3.4.2. Calibrate Delay Chain 446
 - 4.3.5. SMHC DMA Controller Description 446
 - 4.3.5.1. IDMAC Descriptor Structure 447
 - 4.3.5.2. DES0 definition 447
 - 4.3.5.3. DES1 definition 448
 - 4.3.5.4. DES2 definition 448
 - 4.3.5.5. DES3 definition 448
 - 4.3.6. SMHC Register List 448
 - 4.3.7. SMHC Register Description 450
 - 4.3.7.1. SMHC Global Control Register(Default Value: 0x00000300) 450
 - 4.3.7.2. SMHC Clock Control Register(Default Value: 0x00000000) 451
 - 4.3.7.3. SMHC Timeout Register (Default Value: 0xFFFFF40) 452
 - 4.3.7.4. SMHC Bus Width Register (Default Value: 0x00000000) 452
 - 4.3.7.5. SMHC Block Size Register (Default Value: 0x00000200) 452
 - 4.3.7.6. SMHC Block Count Register (Default Value: 0x00000200) 452
 - 4.3.7.7. SMHC Command Register (Default Value: 0x00000000) 453

4.3.7.8.	SMHC Command Argument Register (Default Value: 0x00000000).....	454
4.3.7.9.	SMHC Response 0 Register (Default Value: 0x00000000)	455
4.3.7.10.	SMHC Response 1 Register (Default Value: 0x00000000)	455
4.3.7.11.	SMHC Response 2 Register (Default Value: 0x00000000)	455
4.3.7.12.	SMHC Response 3 Register (Default Value: 0x00000000)	455
4.3.7.13.	SMHC Interrupt Mask Register (Default Value: 0x00000000)	456
4.3.7.14.	SMHC Masked Interrupt Status Register (Default Value: 0x00000000).....	457
4.3.7.15.	SMHC Raw Interrupt Status Register (Default Value: 0x00000000)	458
4.3.7.16.	SMHC Status Register (Default Value: 0x00000006)	460
4.3.7.17.	SMHC FIFO Water Level Register (Default Value: 0x000F0000)	461
4.3.7.18.	SMHC Function Select Register (Default Value: 0x00000000).....	462
4.3.7.19.	SMHC Transferred Byte Count Register0 (Default Value: 0x00000000)	463
4.3.7.20.	SMHC Transferred Byte Count Register1 (Default Value: 0x00000000)	463
4.3.7.21.	SMHC CRC Status Detect Control Register (Default Value: 0x00000003).....	463
4.3.7.22.	SMHC Auto Command 12 Register (Default Value: 0x0000ffff)	464
4.3.7.23.	SMHC NewTiming Set Register (Default Value: 0x00000000).....	464
4.3.7.24.	SMHC Hardware Reset Register (Default Value: 0x00000001).....	464
4.3.7.25.	SMHC DMAC Control Register (Default Value: 0x00000000)	465
4.3.7.26.	SMHC Descriptor List Base Address Register (Default Value: 0x00000000)	465
4.3.7.27.	SMHC DMAC Status Register (Default Value: 0x0000_0000)	466
4.3.7.28.	SMHC DMAC Interrupt Enable Register (Default Value: 0x00000000).....	467
4.3.7.29.	SMHC Card Threshold Control Register (Default Value: 0x00000000)	468
4.3.7.30.	SMHC eMMC4.5 DDR Start Bit Detection Control Register (Default Value: 0x00000000).....	468

4.3.7.31.	SMHC Response CRC Register (Default Value: 0x00000000).....	469
4.3.7.32.	SMHC Data7 CRC Register (Default Value: 0x00000000).....	469
4.3.7.33.	SMHC Data6 CRC Register (Default Value: 0x00000000).....	469
4.3.7.34.	SMHC Data5 CRC Register (Default Value: 0x00000000).....	470
4.3.7.35.	SMHC Data4 CRC Register (Default Value: 0x00000000).....	470
4.3.7.36.	SMHC Data3 CRC Register (Default Value: 0x00000000).....	470
4.3.7.37.	SMHC Data2 CRC Register (Default Value: 0x00000000).....	471
4.3.7.38.	SMHC Data1 CRC Register (Default Value: 0x00000000).....	471
4.3.7.39.	SMHC Data0 CRC Register (Default Value: 0x00000000).....	471
4.3.7.40.	SMHC CRC Status Register (Default Value: 0x00000000)	472
4.3.7.41.	SMHC Drive Delay Control Register (Default Value: 0x00000000)	472
4.3.7.42.	SMHC Sample Delay Control Register (Default Value: 0x00002000).....	473
4.3.7.43.	SMHC Data Strobe Delay Control Register (Default Value: 0x00002000).....	473
4.3.7.44.	SMHC FIFO Register (Default Value: 0x00000000)	474
Chapter 5	Image	475
5.1.	CSI	475
5.1.1.	Overview	475
5.1.2.	Functionalities Description	476
5.1.2.1.	Block Diagram	476
5.1.2.2.	CSI FIFO Distribution	477
5.1.2.3.	CSI Timing	477
5.1.2.4.	CCIR656 Header Code.....	478
5.1.2.5.	Camera Communication Interface	478
5.1.3.	CSI Register list.....	480

- 5.1.4. CSI Register Description 481
 - 5.1.4.1. CSI Enable Register (Default Value: 0x00000000) 481
 - 5.1.4.2. CSI Interface Configuration Register (Default Value: 0x00000000)..... 482
 - 5.1.4.3. CSI Capture Register (Default Value: 0x00000000) 483
 - 5.1.4.4. CSI Synchronization Counter Register (Default Value: 0x00000000)..... 484
 - 5.1.4.5. CSI FIFO Threshold Register (Default Value: 0x040f0400)..... 484
 - 5.1.4.6. CSI Pattern Generation Length Register (Default Value: 0x00000000) 484
 - 5.1.4.7. CSI Pattern Generation Address Register (Default Value: 0x00000000)..... 484
 - 5.1.4.8. CSI Version Register (Default Value: 0x00000000) 485
 - 5.1.4.9. CSI Channel_0 configuration Register (Default Value: 0x00300200)..... 485
 - 5.1.4.10. CSI Channel_0 scale Register (Default Value: 0x00000000) 487
 - 5.1.4.11. CSI Channel_0 FIFO 0 output buffer-A address Register (Default Value: 0x00000000)488
 - 5.1.4.12. CSI Channel_0 FIFO 1 output buffer-A address Register (Default Value: 0x00000000)488
 - 5.1.4.13. CSI Channel_0 FIFO 2 output buffer-A address Register (Default Value: 0x00000000)488
 - 5.1.4.14. CSI Channel_0 status Register (Default Value: 0x00000000) 488
 - 5.1.4.15. CSI Channel_0 interrupt enable Register (Default Value: 0x00000000)..... 489
 - 5.1.4.16. CSI Channel_0 interrupt status Register (Default Value: 0x00000000) 490
 - 5.1.4.17. CSI Channel_0 horizontal size Register (Default Value: 0x05000000) 490
 - 5.1.4.18. CSI Channel_0 vertical size Register (Default Value: 0x01E00000)..... 490
 - 5.1.4.19. CSI Channel_0 buffer length Register (Default Value: 0x01400280) 491
 - 5.1.4.20. CSI Channel_0 flip size Register (Default Value: 0x01E00280) 491
 - 5.1.4.21. CSI Channel_0 frame clock counter Register (Default Value: 0x00000000) 491
 - 5.1.4.22. CSI Channel_0 accumulated and internal clock counter Register (Default Value: 0x00000000) 492

- 5.1.4.23. CSI Channel_0 FIFO Statistic Register (Default Value: 0x00000000) 492
- 5.1.4.24. CSI Channel_0 PCLK Statistic Register (Default Value: 0x00007FFF) 492
- 5.1.4.25. CCI Control Register (Default Value: 0x00000000) 493
- 5.1.4.26. CCI Transmission Configuration Register (Default Value: 0x10000000) 494
- 5.1.4.27. CCI Packet Format Register (Default Value: 0x00110001) 495
- 5.1.4.28. CCI Bus Control Register (Default Value: 0x00002500) 495
- 5.1.4.29. CCI Interrupt Control Register (Default Value: 0x00000000) 496
- 5.1.4.30. CCI Line Counter Trigger Control Register (Default Value: 0x00000000) 496
- 5.1.4.31. CCI FIFO Access Register (Default Value: 0x00000000) 496
- Chapter 6 Display 498
 - 6.1. DE2.0 499
 - 6.1.1. Overview 499
 - 6.2. TCON 500
 - 6.2.1. Overview 500
 - 6.2.2. Block Diagram 500
 - 6.2.3. Functionalities Description 501
 - 6.2.3.1. Panel Interface 501
 - 6.2.3.2. RGB gamma correction 506
 - 6.2.3.3. CEU module 506
 - 6.2.3.4. CMAP module 507
 - 6.2.4. TCON0 Module Register List 507
 - 6.2.5. TCON0 Module Register Description 508
 - 6.2.5.1. TCON Global Control Register (Default Value: 0x00000000) 508
 - 6.2.5.2. TCON Global Interrupt Register0 (Default Value: 0x00000000) 509

6.2.5.3.	TCON Global Interrupt Register1 (Default Value: 0x00000000)	510
6.2.5.4.	TCON FRM Control Register0 (Default Value: 0x00000000)	510
6.2.5.5.	TCON FRM Seed Register0 (Default Value: 0x00000000)	511
6.2.5.6.	TCON FRM Table Register0 (Default Value: 0x00000000)	511
6.2.5.7.	TCON 3D FIFO Register0 (Default Value: 0x00000000)	512
6.2.5.8.	TCON0 Control Register (Default Value: 0x00000000)	512
6.2.5.9.	TCON0 Data Clock Register (Default Value: 0x00000000)	513
6.2.5.10.	TCON0 Basic0 Register (Default Value: 0x00000000)	514
6.2.5.11.	TCON0 Basic1 Register (Default Value: 0x00000000)	514
6.2.5.12.	TCON0 Basic2 Register (Default Value: 0x00000000)	514
6.2.5.13.	TCON0 Basic3 Register (Default Value: 0x00000000)	515
6.2.5.14.	TCON0 HV Panel Interface Register (Default Value: 0x00000000)	515
6.2.5.15.	TCON0 CPU Panel Interface Register (Default Value: 0x00000000)	516
6.2.5.16.	TCON0 CPU Panel Write Data Register (Default Value: 0x00000000)	517
6.2.5.17.	TCON0 CPU Panel Read Data 0 Register (Default Value: 0x00000000)	517
6.2.5.18.	TCON0 CPU Panel Read Data 1 Register (Default Value: 0x00000000)	518
6.2.5.19.	TCON0 LVDS Panel Interface Register (Default Value: 0x00000000)	518
6.2.5.20.	TCON0 IO Polarity Register (Default Value: 0x00000000)	519
6.2.5.21.	TCON0 IO Trigger Register (Default Value: 0x00000000)	520
6.2.5.22.	TCON CEU Control Register (Default Value: 0x00000000)	520
6.2.5.23.	TCON CEU Coefficient Mul Register (Default Value: 0x00000000)	520
6.2.5.24.	TCON CEU Coefficient Add Register (Default Value: 0x00000000)	521
6.2.5.25.	TCON CEU Coefficient Range Register (Default Value: 0x00000000)	521
6.2.5.26.	TCON0 CPU Panel Trigger0 Register (Default Value: 0x00000000)	521

6.2.5.27.	TCON0 CPU Panel Trigger1 Register (Default Value: 0x00000000).....	522
6.2.5.28.	TCON0 CPU Panel Trigger2 Register (Default Value: 0x00000000).....	522
6.2.5.29.	TCON0 CPU Panel Trigger3 Register (Default Value: 0x00000000).....	522
6.2.5.30.	TCON0 CPU Panel Trigger4 Register (Default Value: 0x00000000).....	523
6.2.5.31.	TCON0 CPU Panel Trigger5 Register (Default Value: 0x00000000).....	523
6.2.5.32.	TCON Color Map Control Register (Default Value: 0x00000000)	523
6.2.5.33.	TCON Color Map Odd Line0 Register (Default Value: 0x00000000)	524
6.2.5.34.	TCON Color Map Odd Line1 Register (Default Value: 0x00000000)	524
6.2.5.35.	TCON Color Map Even0 Register (Default Value: 0x00000000).....	524
6.2.5.36.	TCON Color Map Even1 Register (Default Value: 0x00000000).....	525
6.2.5.37.	TCON Safe Period Register (Default Value: 0x00000000)	525
6.2.5.38.	TCON0 LVDS ANA0 Register (Default Value: 0x00000000)	525
6.2.6.	TCON1 Module Register List	526
6.2.7.	TCON1 Module Register Description	527
6.2.7.1.	TCON Global Control Register (Default Value: 0x00000000).....	527
6.2.7.2.	TCON Global Interrupt Register0 (Default Value: 0x00000000)	527
6.2.7.3.	TCON Global Interrupt Register1 (Default Value: 0x00000000)	528
6.2.7.4.	TCON1 Control Register (Default Value: 0x00000000)	528
6.2.7.5.	TCON1 Basic Timing 0 Register (Default Value: 0x00000000).....	529
6.2.7.6.	TCON1 Basic Timing 1 Register (Default Value: 0x00000000).....	529
6.2.7.7.	TCON1 Basic Timing 2 Register (Default Value: 0x00000000).....	529
6.2.7.8.	TCON1 Basic Timing 3 Register (Default Value: 0x00000000).....	530
6.2.7.9.	TCON1 Basic Timing Register (Default Value: 0x00000000).....	530
6.2.7.10.	TCON1 Basic Timing 5 Register (Default Value: 0x00000000).....	530

6.2.7.11.	TCON1 PS SYNC Register (Default Value: 0x00000000)	531
6.2.7.12.	TCON1 IO Polarity Register (Default Value: 0x00000000)	531
6.2.7.13.	TCON1 IO Polarity Register (Default Value: 0x0FFFFFFF).....	531
6.2.7.14.	TCON CEU Control Register (Default Value: 0x00000000).....	532
6.2.7.15.	TCON CEU Coefficient Mul Register (Default Value: 0x00000000).....	532
6.2.7.16.	TCON CEU Coefficient Add Register (Default Value: 0x00000000).....	533
6.2.7.17.	TCON CEU Coefficient Rang Register (Default Value: 0x00000000)	533
6.2.7.18.	TCON Safe Period Register (Default Value: 0x00000000)	533
6.2.7.19.	TCON1 Fill Control Register (Default Value: 0x00000000).....	534
6.2.7.20.	TCON1 Fill Begin Register (Default Value: 0x00000000)	534
6.2.7.21.	TCON1 Fill End Register (Default Value: 0x00000000)	534
6.2.7.22.	TCON1 Fill Data Register (Default Value: 0x00000000).....	534
Chapter 7	Interfaces	535
7.1.	TWI.....	536
7.1.1.	Overview	536
7.1.2.	Timing Diagram.....	536
7.1.3.	TWI Controller Special Requirement.....	537
7.1.3.1.	TWI Pin List	537
7.1.3.2.	TWI Controller Operation	537
7.1.4.	TWI Controller Register List	538
7.1.5.	TWI Controller Register Description	538
7.1.5.1.	TWI Slave Address Register(Default Value: 0x00000000)	538
7.1.5.2.	TWI Extend Address Register(Default Value: 0x00000000).....	539
7.1.5.3.	TWI Data Register(Default Value: 0x00000000)	539

- 7.1.5.4. TWI Control Register(Default Value: 0x00000000)..... 539
- 7.1.5.5. TWI Status Register(Default Value: 0x000000F8)..... 541
- 7.1.5.6. TWI Clock Register(Default Value: 0x00000000)..... 542
- 7.1.5.7. TWI Soft Reset Register(Default Value: 0x00000000) 542
- 7.1.5.8. TWI Enhance Feature Register(Default Value: 0x00000000)..... 542
- 7.1.5.9. TWI Line Control Register(Default Value: 0x0000003A)..... 543
- 7.1.5.10. TWI DVFS Register(Default Value: 0x00000000) 544
- 7.2. SPI 545
 - 7.2.1. Overview 545
 - 7.2.2. SPI Block Diagram 545
 - 7.2.3. SPI Timing Diagram 546
 - 7.2.4. SPI Pin Lists..... 547
 - 7.2.5. SPI Register List 548
 - 7.2.6. SPI Register Description 548
 - 7.2.6.1. SPI Global Control Register(Default Value: 0x00000080) 548
 - 7.2.6.2. SPI Transfer Control Register(Default Value: 0x00000087) 549
 - 7.2.6.3. SPI Interrupt Control Register(Default Value: 0x00000000) 551
 - 7.2.6.4. SPI Interrupt Status Register(Default Value: 0x00000022)..... 553
 - 7.2.6.5. SPI FIFO Control Register(Default Value: 0x00400001) 554
 - 7.2.6.6. SPI FIFO Status Register(Default Value: 0x00000000) 555
 - 7.2.6.7. SPI Wait Clock Register(Default Value: 0x00000000) 556
 - 7.2.6.8. SPI Clock Control Register(Default Value: 0x00000002)..... 557
 - 7.2.6.9. SPI Master Burst Counter Register(Default Value: 0x00000000)..... 557
 - 7.2.6.10. SPI Master Transmit Counter Register(Default Value: 0x00000000) 557

- 7.2.6.11. SPI Master Burst Control Counter Register(Default Value: 0x00000000)..... 558
- 7.2.6.12. SPI Normal DMA Mode Control Register(Default Value: 0x000000A5)..... 559
- 7.2.6.13. SPI TX Data Register(Default Value: 0x00000000)..... 559
- 7.2.6.14. SPI RX Data Register(Default Value: 0x00000000)..... 559
- 7.3. UART 560
 - 7.3.1. Overview 560
 - 7.3.2. UART Timing Diagram 561
 - 7.3.3. UART Pin List 561
 - 7.3.4. UART Controller Register List 562
 - 7.3.5. UART Register Description 563
 - 7.3.5.1. UART Receiver Buffer Register(Default Value: 0x00000000)..... 563
 - 7.3.5.2. UART Transmit Holding Register(Default Value: 0x00000000) 563
 - 7.3.5.3. UART Divisor Latch Low Register(Default Value: 0x00000000) 564
 - 7.3.5.4. UART Divisor Latch High Register(Default Value: 0x00000000) 564
 - 7.3.5.5. UART Interrupt Enable Register(Default Value: 0x00000000)..... 565
 - 7.3.5.6. UART Interrupt Identity Register(Default Value: 0x00000000) 565
 - 7.3.5.7. UART FIFO Control Register(Default Value: 0x00000000) 567
 - 7.3.5.8. UART Line Control Register(Default Value: 0x00000000)..... 568
 - 7.3.5.9. UART Modem Control Register(Default Value: 0x00000000)..... 569
 - 7.3.5.10. UART Line Status Register(Default Value: 0x00000060)..... 571
 - 7.3.5.11. UART Modem Status Register(Default Value: 0x00000000)..... 573
 - 7.3.5.12. UART Scratch Register(Default Value: 0x00000000)..... 575
 - 7.3.5.13. UART Status Register(Default Value: 0x00000006) 575
 - 7.3.5.14. UART Transmit FIFO Level Register(Default Value: 0x00000000) 576

7.3.5.15.	UART Receive FIFO Level Register(Default Value: 0x00000000).....	576
7.3.5.16.	UART Halt TX Register(Default Value: 0x00000000).....	576
7.4.	CIR Receiver	578
7.4.1.	Overview	578
7.4.2.	CIR Receiver Register List	578
7.4.3.	CIR Receiver Register Description	579
7.4.3.1.	CIR Receiver Control Register(Default Value: 0x00000000)	579
7.4.3.2.	CIR Receiver Configure Register(Default Value: 0x00000004).....	579
7.4.3.3.	CIR Receiver FIFO Register(Default Value: 0x00000000)	580
7.4.3.4.	CIR Receiver Interrupt Control Register(Default Value: 0x00000000).....	580
7.4.3.5.	CIR Receiver Status Register(Default Value: 0x00000000)	580
7.4.3.6.	CIR Receiver Configure Register(Default Value: 0x00000000).....	581
7.5.	USB.....	583
7.5.1.	USB Controller Block Diagram.....	583
7.5.2.	USB OTG	584
7.5.2.1.	Overview	584
7.5.3.	USB Host	584
7.5.3.1.	Overview	584
7.5.3.2.	USB Host Timing Diagram.....	585
7.5.3.3.	USB Host Register List	585
7.5.3.4.	EHCI Register Description	586
7.5.3.5.	OHCI Register Description	601
7.5.3.6.	HCI Interface Control and Status Register Description	618
7.5.3.7.	USB Host Clock Requirement.....	620

- 7.6. I2S/PCM 621
 - 7.6.1. Overview 621
 - 7.6.2. Signal Description 621
 - 7.6.2.1. I2S/PCM Pin List 621
 - 7.6.2.2. Digital Audio Interface Clock Source and Frequency 622
 - 7.6.3. Functionalities Description 622
 - 7.6.3.1. Typical Applications 622
 - 7.6.3.2. Functional Block Diagram 622
 - 7.6.4. Timing Diagram 623
 - 7.6.5. Operation Modes 625
 - 7.6.5.1. System setup and I2S/PCM initialization 625
 - 7.6.5.2. The channel setup and DMA setup 625
 - 7.6.5.3. Enable and disable the I2S/PCM 625
 - 7.6.6. I2S/PCM Register List 626
 - 7.6.7. I2S/PCM Register Description 626
 - 7.6.7.1. I2S/PCM Control Register(Default Value: 0x00060000) 626
 - 7.6.7.2. I2S/PCM Format Register0 (Default Value: 0x00000033) 628
 - 7.6.7.3. I2S/PCM Format Register1 (Default Value: 0x00000030) 629
 - 7.6.7.4. I2S/PCM Interrupt Status Register(Default Value: 0x00000010) 630
 - 7.6.7.5. I2S/PCM RX FIFO Register(Default Value: 0x00000000) 631
 - 7.6.7.6. I2S/PCM FIFO Control Register (Default Value: 0x000400F0) 631
 - 7.6.7.7. I2S/PCM FIFO Status Register (Default Value: 0x10800000) 632
 - 7.6.7.8. I2S/PCM DMA & Interrupt Control Register(Default Value: 0x00000000) 632
 - 7.6.7.9. I2S/PCM TX FIFO Register(Default Value: 0x00000000) 633

- 7.6.7.10. I2S/PCM Clock Divide Register(Default Value: 0x00000000)..... 634
- 7.6.7.11. I2S/PCM TX Counter Register(Default Value: 0x00000000) 635
- 7.6.7.12. I2S/PCM RX Counter Register(Default Value: 0x00000000) 635
- 7.6.7.13. I2S/PCM Channel Configuration Register(Default Value: 0x00000000) 635
- 7.6.7.14. I2S/PCM TXn Channel Select Register(Default Value: 0x00000000) 636
- 7.6.7.15. I2S/PCM TXn Channel Mapping Register(Default Value: 0x00000000)..... 636
- 7.6.7.16. I2S/PCM RX Channel Select Register(Default Value: 0x00000000) 638
- 7.6.7.17. I2S/PCM RX Channel Mapping Register(Default Value: 0x00000000)..... 638
- 7.7. OWA..... 640
 - 7.7.1. Overview 640
 - 7.7.2. Functional Description 640
 - 7.7.2.1. OWA Interface Pin List 640
 - 7.7.2.2. OWA Clock Requirement 640
 - 7.7.2.3. OWA Block Diagram..... 640
 - 7.7.2.4. OWA Frame Format 641
 - 7.7.2.5. Operation Modes..... 642
 - 7.7.3. OWA Register List..... 643
 - 7.7.4. OWA Register Description..... 644
 - 7.7.4.1. OWA General Control Register(Default Value : 0x00000080)..... 644
 - 7.7.4.2. OWA TX Configure Register(Default Value: 0x000000F0)..... 644
 - 7.7.4.3. OWA RX Configure Register(Default Value: 0x00000000) 645
 - 7.7.4.4. OWA Interrupt Status Register(Default Value: 0x00000010)..... 646
 - 7.7.4.5. OWA RX FIFO Register(Default Value: 0x00000000)..... 647
 - 7.7.4.6. OWA FIFO Control Register(Default Value: 0x00001078) 647

- 7.7.4.7. OWA FIFO Status Register(Default Value: 0x00006000) 648
- 7.7.4.8. OWA Interrupt Control Register(Default Value: 0x00000000)..... 648
- 7.7.4.9. OWA TX FIFO Register(Default Value: 0x00000000) 650
- 7.7.4.10. OWA TX Counter Register(Default Value: 0x00000000) 650
- 7.7.4.11. OWA RX Counter Register(Default Value: 0x00000000) 650
- 7.7.4.12. OWA TX Channel Status Register0(Default Value: 0x00000000) 650
- 7.7.4.13. OWA TX Channel Status Register1(Default Value: 0x00000000) 652
- 7.7.4.14. OWA RX Channel Status Register0(Default Value: 0x00000000) 653
- 7.7.4.15. OWA RX Channel Status Register1(Default Value: 0x00000000) 654
- 7.8. SCR..... 656
 - 7.8.1. Overview 656
 - 7.8.2. Block Diagram 656
 - 7.8.3. SCR Timing Diagram..... 657
 - 7.8.4. SCR Special Requirement 657
 - 7.8.4.1. Clock Generator 657
 - 7.8.4.2. SCIO Pad Configuration 658
 - 7.8.5. SCR Register List 659
 - 7.8.6. SCR Register Description 659
 - 7.8.6.1. Smart Card Reader Control and Status Register(Default Value: 0x00000000) 659
 - 7.8.6.2. Smart Card Reader Interrupt Enable Register(Default Value: 0x00000000)..... 661
 - 7.8.6.3. Smart Card Reader Interrupt Status Register(Default Value: 0x00000000)..... 662
 - 7.8.6.4. Smart Card Reader FIFO Control and Status Register(Default Value: 0x00000000) 663
 - 7.8.6.5. Smart Card Reader FIFO Counter Register(Default Value: 0x00000000)..... 664
 - 7.8.6.6. Smart Card Reader Repeat Control Register(Default Value: 0x00000000) 664

- 7.8.6.7. Smart Card Reader Clock Divisor Register(Default Value: 0x00000000)..... 665
- 7.8.6.8. Smart Card Reader Line Time Register(Default Value: 0x00000000) 665
- 7.8.6.9. Smart Card Reader Character Time Register(Default Value: 0x00000000) 666
- 7.8.6.10. Smart Card Reader Line Control Register(Default Value: 0x00000000)..... 666
- 7.8.6.11. Smart Card Reader FIFO Data Register(Default Value: 0x00000000)..... 667
- 7.9. EMAC 668
 - 7.9.1. Overview 668
 - 7.9.2. Block Diagram 668
 - 7.9.3. EMAC Core Register List 669
 - 7.9.4. EMAC Core Register Description 670
 - 7.9.4.1. Basic Control 0 Register(Default Value: 0x00000000) 670
 - 7.9.4.2. Basic Control 1 Register(Default Value: 0x08000000) 671
 - 7.9.4.3. Interrupt Status Register(Default Value: 0x00000000)..... 671
 - 7.9.4.4. Interrupt Enable Register(Default Value: 0x00000000)..... 672
 - 7.9.4.5. Transmit Control 0 Register(Default Value: 0x00000000)..... 673
 - 7.9.4.6. Transmit Control 1 Register(Default Value: 0x00000000)..... 673
 - 7.9.4.7. Transmit Flow Control Register(Default Value: 0x00000000) 674
 - 7.9.4.8. Transmit DMA Descriptor List Address Register(Default Value: 0x00000000)..... 675
 - 7.9.4.9. Receive Control 0 Register(Default Value: 0x00000000) 675
 - 7.9.4.10. Receive Control 1 Register(Default Value: 0x00000000) 676
 - 7.9.4.11. Receive DMA Descriptor List Address Register(Default Value: 0x00000000) 677
 - 7.9.4.12. Receive Frame Filter Register(Default Value: 0x00000000) 677
 - 7.9.4.13. Receive Hash Table 0 Register(Default Value: 0x00000000) 678
 - 7.9.4.14. Receive Hash Table 1 Register(Default Value: 0x00000000) 679

- 7.9.4.15. MII Command Register(Default Value: 0x00000000) 679
- 7.9.4.16. MII Data Register(Default Value: 0x00000000) 680
- 7.9.4.17. MAC Address 0 High Register(Default Value: 0x0000FFFF) 680
- 7.9.4.18. MAC Address 0 Low Register(Default Value: 0xFFFFFFFF)..... 680
- 7.9.4.19. MAC Address x High Register(Default Value: 0x0000FFFF) 680
- 7.9.4.20. MAC Address x Low Register(Default Value: 0xFFFFFFFF) 681
- 7.9.4.21. Transmit DMA Status Register(Default Value: 0x00000000) 681
- 7.9.4.22. Transmit DMA Current Descriptor Register(Default Value: 0x00000000)..... 681
- 7.9.4.23. Transmit DMA Current Buffer Address Register(Default Value: 0x00000000)..... 681
- 7.9.4.24. Receive DMA Status Register(Default Value: 0x00000000)..... 682
- 7.9.4.25. Receive DMA Current Descriptor Register(Default Value: 0x00000000)..... 682
- 7.9.4.26. Receive DMA Current Buffer Address Register(Default Value: 0x00000000) 682
- 7.9.4.27. RGMII Status Register(Default Value: 0x00000000) 682
- 7.9.5. EMAC RX/TX Descriptor 683
 - 7.9.5.1. Transmit Descriptor 683
 - 7.9.5.2. Receive Descriptor 685
- 7.10. TSC 687
 - 7.10.1. Overview 687
 - 7.10.2. Transport Stream Input Timing Diagram 688
 - 7.10.3. Transport Stream Controller Register List 690
 - 7.10.4. Transport Stream Controller Register Description 691
 - 7.10.4.1. TSC Control Register(Default Value: 0x00000000)..... 691
 - 7.10.4.2. TSC Status Register(Default Value: 0x00000000) 691
 - 7.10.4.3. TSC Port Control Register(Default Value: 0x00000000) 691

7.10.4.4. TSC Port Parameter Register(Default Value: 0x00000000) 691

7.10.4.5. TSC TSF Input Multiplex Control Register(Default Value: 0x00000000)..... 692

7.10.4.6. TSC Port Output Multiplex Control Register(Default Value: 0x00000000)..... 692

7.10.4.7. TSC Port Output Multiplex Control Register(Default Value: 0x00000000)..... 693

7.10.4.8. TSG Packet Parameter Register(Default Value: 0x00470000) 694

7.10.4.9. TSG Interrupt Enable and Status Register(Default Value: 0x00000000) 694

7.10.4.10. TSG Clock Control Register(Default Value: 0x00000000) 695

7.10.4.11. TSG Buffer Base Address Register(Default Value: 0x00000000) 695

7.10.4.12. TSG Buffer Size Register(Default Value: 0x00000000)..... 696

7.10.4.13. TSG Buffer Point Register(Default Value: 0x00000000) 696

7.10.4.14. TSF Control and Status Register(Default Value: 0x00000000) 696

7.10.4.15. TSF Packet Parameter Register(Default Value: 0x00470000) 696

7.10.4.16. TSF Interrupt Enable and Status Register(Default Value: 0x00000000) 697

7.10.4.17. TSF DMA Interrupt Enable Register(Default Value: 0x00000000)..... 698

7.10.4.18. TSF Overlap Interrupt Enable Register(Default Value: 0x00000000) 698

7.10.4.19. TSF DMA Interrupt Status Register(Default Value: 0x00000000)..... 699

7.10.4.20. TSF Overlap Interrupt Status Register(Default Value: 0x00000000) 699

7.10.4.21. TSF PCR Control Register(Default Value: 0x00000000) 699

7.10.4.22. TSF PCR Data Register(Default Value: 0x00000000) 700

7.10.4.23. TSF Channel Enable Register(Default Value: 0x00000000) 700

7.10.4.24. TSF PES Enable Register(Default Value: 0x00000000)..... 700

7.10.4.25. TSF Channel Descramble Enable Register(Default Value: 0x00000000) 700

7.10.4.26. TSF Channel Index Register(Default Value: 0x00000000) 701

7.10.4.27. TSF Channel Control Register(Default Value: 0x00000000) 701

7.10.4.28.	TSF Channel Status Register(Default Value: 0x00000000)	701
7.10.4.29.	TSF Channel CW Index Register(Default Value: 0x00000000).....	701
7.10.4.30.	TSF Channel PID Register(Default Value: 0x1FFF0000)	702
7.10.4.31.	TSF Channel Buffer Base Address Register(Default Value: 0x00000000)	702
7.10.4.32.	TSF Channel Buffer Size Register(Default Value: 0x00000000)	702
7.10.4.33.	TSF Channel Write Pointer Register(Default Value: 0x00000000).....	703
7.10.4.34.	TSF Channel Read Pointer Register(Default Value: 0x00000000).....	703
7.10.4.35.	TSD Control Register(Default Value: 0x00000000).....	703
7.10.4.36.	TSD Status Register(Default Value: 0x00000000).....	703
7.10.4.37.	TSD Control Word Index Register(Default Value: 0x00000000)	704
7.10.4.38.	TSD Control Word Register(Default Value: 0x00000000).....	704
Appendix.....		705

Chapter 1 About This Documentation

1.1. Documentation Overview

This documentation provides an overall description of the Allwinner quad-core A64 application processor, which will provide instructions to programmers from several sections, including overview, system, memory, image, display and interfaces.

1.2. Acronyms and abbreviations

The table below contains acronyms and abbreviations used in this document.

AES	Advanced Encryption Standard
ADC	Analog-to-digital converter
AGC	Automatic Gain Control
AHB	AMBA High-speed Bus
APB	Advanced Peripheral Bus
ARM	Advanced RISC Machine
AVS	Audio Video Standard
CIR	Consumer Infrared
CP15	Coprocessor 15
CPU	Central processing unit
CRC	Cyclic Redundancy Check
CSI	Camera Serial Interface
DES	Data Encryption Standard
DLL	Delay-Locked Loop
DMA	Direct Memory Access
DRC	Dynamic Range Compression
DSI	MIPI Display Serial Interface
DVFS	Dynamic Voltage and Frequency Scaling
eFuse	Electrical Fuse, A one-time programmable memory
EHCI	Enhanced Host Controller Interface
eMMC	Embedded Multi-Media Card
FBGA	Fine Ball Grid Array
FIFO	First in First out
GIC	Generic Interrupt Controller
GPIO	General Purpose Input Output
HDMI	High-Definition Multimedia Interface

I2S	Inter IC Sound
JEDEC	Joint Electron Device Engineering Council
JPEG	Joint Photographic Experts Group
JTAG	Joint Test Action Group
KEYADC	Analog to Digital Converter
LCD	Liquid-Crystal Display
LSB	Least Significant Bit
LVDS	Low Voltage Differential Signaling
MAC	Media Access Control
MII	Media Independent Interface
MIPI	Mobile Industry Processor Interface
MIPI DSI	MIPI Display Serial Interface
MMC	Multimedia Card
MPEG	Motion Pictures Expert Group
MPEG1	The First MPEG Compression Scheme Specification
MPEG4	The Most Current MPEG Compression Scheme Specification
MSB	Most Significant Bit
NTSC	National Television System Committee
OHCI	Open Host Controller Interface
OWA	One Wire Audio
PAL	Phase Alternating Line
PCM	Pulse Code Modulation
PHY	Physical Layer Controller
PID	Packet Identifier
PLL	Phase-Locked Loop
RSB™	Reduced Serial Bus
SDIO	Secure Digital Input Output
SOC	System on a chip
SPI	Serial Peripheral Interface
TWI	Two Wire Interface
USB OTG	Universal Serial Bus On The Go
UART	Universal Asynchronous Receiver Transmitter

Chapter 2 Overview

Allwinner's A64 is a quad-core, 64bit SoC targeted for high performance tablets. A64 integrates a higher energy efficiency ARM Cortex-A53 CPU architecture, and also includes advanced 3D graphics processing unit, high-definition video encoding/decoding, low power audio codec, excellent display controllers and a broad range of interfaces.

The processor has some very exciting features:

- **CPU** Quad-core ARM Cortex-A53 Processor, a power-efficient ARM v8 architecture, it has 64 and 32bit execution states for scalable high performance, which includes a NEON multimedia processing engine.
- **Graphics** ARM Mali400MP2 graphics acceleration provides mobile users with superior experience in web browsing, video playback and gaming effects; OpenGL ES2.0, OpenVG1.1 standards are supported.
- **Video** A64 provides almost full motion playback of up to 4K high-definition video, and supports H.265 decoder by 4K@30fps, H.264 decoder by 1080p@60fps, MPEG1/2/4 decoder by 1080p@60fps, VP8 decoder by 1080p@60fps, AVS/AVS+ decoder by 1080p@60fps, VC1 decoder by 1080p@30fps, H.264 encoder by 1080p@60fps with dedicated hardware.
- **Audio** An integrated audio subsystem delivers extremely low power audio playback and exceptional high quality sound.
- **Display** A64 features Allwinner's SmartColor2.0™ technology with an integrated display engine. Content can be displayed on 4-lane MIPI DSI displays up to 1920x1200@60fps, or a RGB panel interface up to 1920x1200@60fps, or LVDS panel up to 1366x768@60fps, or HDMI v1.4 is also supported up to 4K@30fps.
- **External Memory** Many types of external memory devices are supported, including LPDDR2, LPDDR3, DDR2, DDR3, DDR3L, NAND Flash(MLC,SLC,TLC,EF), Nor Flash, SD/SDIO/MMC including eMMC up to rev5.0, and also supports booting from RAW NAND, eMMC, SD/TF Card or Nor Flash.
- **Security** A64 delivers hardware security features that enable trustzone security system, Digital Rights Management(DRM), information encryption/decryption, secure boot, secure JTAG and secure efuse.
- **Connectivity** A64 has a broad range of hardware interfaces such as parallel CMOS sensor interface, 10/100/1000Mbps EMAC, USB OTG v2.0 operating at high speed(480Mbps) with PHY, USB Host with PHY and a variety of other popular interfaces(SPI, UART, CIR, TS, TWI, RSB, SCR).

2.1. Processor Features

2.1.1. CPU Architecture

- Quad-core ARM Cortex-A53 Processor
- A power-efficient ARM v8 architecture
- 64 and 32bit execution states for scalable high performance
- Trustzone technology supported
- 3~10x better software encryption performance
- Support NEON Advanced SIMD(Single Instruction Multiple Data)instruction for acceleration of media and signal processing functions
- Support Large Physical Address Extensions(LPAE)
- VFPv4 Floating Point Unit
- 32KB L1 Instruction cache and 32KB L1 Data cache
- 512KB L2 cache

2.1.2. GPU Architecture

- ARM Mali400MP2 GPU
- Support OpenGL ES 2.0 and OpenVG 1.1 standard

2.1.3. Memory Subsystem

2.1.3.1. Boot ROM

- On-chip memory
- Size:112KB(non secure ROM:48KB,secure ROM:64KB)
- Support secure and non-secure access boot
- Support system boot from the following devices:
 - NAND Flash
 - SD/TF card
 - eMMC
 - Nor Flash
- Support system code download through USB OTG

2.1.3.2. SDRAM

- Compatible with JEDEC standard DDR2/DDR3/DDR3L/LPDDR2/LPDDR3 SDRAM
- Support clock frequency up to 667MHz(DDR3-1333)
- Up to 3GB address space
- Support 2 chip select
- 16 address signal lines and 3 bank signal lines
- 32-bits data width
- Support Memory Dynamic Frequency Scale(MDFS)

2.1.3.3. NAND Flash

- Up to 2 flash chips
- 8-bit data bus width
- Up to 64-bit ECC per 1024 bytes
- Support 1024, 2048, 4096, 8192, 16K bytes size per page
- Support SLC/MLC/TLC flash and EF-NAND memory
- Support SDR, ONFI DDR and Toggle DDR NAND
- Embedded DMA to do data transfer
- Support data transfer together with normal DMA

2.1.3.4. SD/MMC

- Up to three SD/MMC controller interfaces
- Comply to eMMC standard specification V5.0, SD physical layer specification V2.0, SDIO card specification V3.0
- 1-bit or 4-bit data bus transfer mode for SD cards
- 1-bit or 4-bit data bus transfer mode for SDIO interface
- 1-bit ,4-bit or 8-bit data bus transfer mode for MMC cards
- Embedded special DMA to do data transfer
- Support hardware CRC generation and error detection

2.1.4. System Peripheral

2.1.4.1. Timer

- Two on-chip timers with interrupt-based operation
- One watchdogs to generate reset signal or interrupts
- Two AVS Counter to synchronize video and audio in the player

- 24MHz or 32KHz clock input

2.1.4.2. High Speed Timer

- One high speed timer with 56bit counter
- Clock source is synchronized with AHB1 clock, much more accurate than other timers

2.1.4.3. RTC

- Calendar :Counters second,minutes,hours,day,week,month and year with leap year generator
- Alarm:general alarm and weekly alarm
- One 32768Hz fanout

2.1.4.4. GIC

- Support 16 Software Generated Interrupts(SGIs), 16 Private Peripheral Interrupts(PPIs) and 125 Shared Peripheral Interrupts(SPIs)

2.1.4.5. DMA

- Up to 8-channels DMA
- Interrupt generated for each DMA channel
- Flexible data width of 8/16/32/64-bits
- Support linear and IO address modes
- Support data transfer types with memory-to-memory, memory-to-peripheral, peripheral-to-memory

2.1.4.6. CCU

- 13 PLLs
- One on-chip RC oscillator
- Support a external 24MHz oscillator and a external32.768KHz oscillator
- Support clock configuration and clock generated for corresponding modules
- Support software-controlled clock gating and software-controlled reset for corresponding modules

2.1.4.7. PWM

- Support outputting two kinds of waveform: continuous waveform and pulse waveform
- 0% to 100% adjustable duty cycle
- Up to 24MHz output frequency

2.1.4.8. Thermal Sensor

- Temperature Accuracy : $\pm 3^{\circ}\text{C}$ from 0°C to $+100^{\circ}\text{C}$, $\pm 5^{\circ}\text{C}$ from -20°C to $+125^{\circ}\text{C}$
- Support over-temperature protection interrupt and over-temperature alarm interrupt
- Averaging filter for thermal sensor reading
- Support 3 sensors:sensor0 for CPU,sensor1/2 for GPU

2.1.4.9. KEYADC

- ADC with 6-bit resolution for key
- Support hold key and continuous key
- Support single key, normal key and continuous key

2.1.4.10. Crypto Engine(CE)

- Support Symmetrical algorithm: AES,DES,TDES
 - Support AES 128/192/256-bits with ECB,CBC,CTS,CTR mode
 - Support DES/TDES with ECB,CBC,CTR mode
- Support Hash algorithm: MD5,SHA1,SHA224,SHA256,HMAC
- Support Asymmetrical algorithm:RSA512/1024/2048bit
- Support 160-bits hardware PRNG with 175-bits seed
- Support 256-bits hardware TRNG
- Internal Embedded DMA to do data transfer
- Support secure and non-secure interfaces respectively

2.1.4.11. Security ID

- Support 2K-bits EFUSE for chip ID and security application

2.1.4.12. CPU Configuration

- Support power clamp
- Flexible CPU configuration

2.1.5. Display Subsystem

2.1.5.1. DE

- Output size up to 4096x4096
- Support four alpha blending channel for main display, two channel for aux display
- Support four overlay layers in each channel, and has a independent scaler
- Support potter-duff compatible blending operation
- Support input format YUV422/YUV420/YUV411/ARGB8888/XRGB8888/RGB888/ARGB4444/ARGB1555 and RGB565
- Support Frame Packing/Top-and-Bottom/Side-by-side Full/Side-by-Side Half 3D format data
- Support SmartColor™ 2.0 for excellent display experience
 - Adaptive edge sharpening
 - Adaptive color enhancement
 - Adaptive contrast enhancement and fresh tone rectify
- Support writeback and rotation for high efficient dual display and miracast

2.1.5.2. Display Output

- Support LVDS interface with single link, up to 1366x768@60fps
- Support RGB interface with DE/SYNC mode, up to 1920x1200@60fps
- Dither function from RGB666/RGB565 to RGB888
- Support 4-lanes MIPI DSI up to 1920x1200@60fps
- Support HDMI1.4 with HDCP1.2 up to 4K@30fps

2.1.6. Video Engine

2.1.6.1. Video Decoding

- Support multi-format video playback, including:
 - H.265:4K@30fps
 - H.264:1080p@60fps
 - MPEG1/2/4:1080p@60fps

- VP8:1080p@60fps
- VC1:1080p@30fps
- AVS/AVS+: 1080p@60fps
- JPEG/MJPEG:1080p@30fps
- Support 1080P blu-ray 3D
- Support frame compatible 3D format,size:3840x1080,1920x2160

2.1.6.2. Video Encoding

- Support H.264 video encoding up to 1080p@60fps
- JPEG baseline: picture size up to 8192x8192
- Support input format: YU12/YV12/NV12/NV21/YUYV/YVYU/UYVY/VYUY/ARGB/BGRA/RGBA/ABGR/YU16/YV16/TILE32/TILE128
- Support Alpha blending
- Support thumb generation
- Support 4x2 scaling ratio: from 1/16 to 64 arbitrary non-integer ratio
- Support rotated input

2.1.7. Image In

2.1.7.1. CSI

- Support 8bit YUV422 CMOS sensor interface
- Support CCIR656 protocol for NTSC and PAL
- Maximum still capture resolution to 5M
- Maximum video capture resolution to 1080p@30fps

2.1.8. Audio Subsystem

2.1.8.1. Audio Codec

- Two audio digital-to-analog(DAC) channels
- Stereo capless headphone drivers:
 - 100dB SNR@A-weight
 - Support DAC Sample Rates from 8KHz to 192KHz
- Support analog/ digital volume control
- Differential earpiece driver
- Analog low-power loop from line-in /microphone to headphone/earpiece outputs

- Support Dynamic Range Controller(DRC) adjusting the DAC playback output
- Accessory button press detection
- Four audio inputs:
 - Two differential microphone inputs
 - One differential Phone input
 - Stereo Line-in L/R input
- Four audio outputs:
 - Earpiece amplifier differential output
 - Phone amplifier differential output
 - Headphone amplifier L/R channel output
 - Line-out L/R output
- Two audio analog-to-digital(ADC) channels
 - 96dB SNR@A-weight
 - Supports ADC Sample Rates from 8KHz to 48KHz
- Support Automatic Gain Control(AGC) and Dynamic Range Control(DRC) adjusting the ADC recording input
- Two PCM interface connected with BB and BT
- One 128x24-bits FIFO for data transmit, one 64x24-bits FIFO for data receive
- Support Audio HUB

2.1.8.2. One Wire Audio(OWA)

- IEC-60958 transmitter and receiver functionality
- Complies with SPDIF Interface
- Support channel status insertion for the transmitter
- Hardware Parity generation on the transmitter
- One 32x24bits FIFO (TX) for audio data transfer
- Programmable FIFO thresholds
- Support Audio HUB

2.1.8.3. I2S/PCM

- Up to two I2S/PCM controllers
- Compliant with standard Inter-IC sound(I2S) bus specification
- Compliant with left-justified, right-justified, PCM mode, and TDM(Time Division Multiplexing) format
- Full-duplex synchronous work mode
- Master and slave mode configured
- Adjustable audio sample resolution from 8-bit to 32-bit
- Sample rate from 8KHz to 192KHz
- Support 8-bits u-law and 8-bits A-law companded sample
- Support programmable PCM frame width:1 BCLK width(short frame) and 2 BCLKs width(long frame)
- Support Audio HUB

2.1.9. External Peripherals

2.1.9.1. USB

- One USB 2.0 OTG, with integrated one USB 2.0 analog PHY
 - Complies with USB2.0 Specification
 - Support High-Speed (HS, 480Mbps), Full-Speed (FS, 12Mbps) and Low-Speed (LS, 1.5Mbps) in host mode
 - Complies with Enhanced Host Controller Interface (EHCI) Specification, Version 1.0, and the Open Host Controller Interface (OHCI) Specification, Version 1.0a for host mode
 - Up to 10 User-Configurable Endpoints for Bulk, Isochronous and Interrupt bi-directional transfers (Endpoint1, Endpoint2, Endpoint3, Endpoint4, Endpoint5)
 - Support 8KB FIFO for EPs (excluding EP0)
 - HCI (EHCI+OHCI) and USB2.0 OTG SIE share USB analog PHY
- One EHCI/OHCI Host, multiplexed with one USB 2.0 analog PHY and one HSIC PHY
 - Complies with Enhanced Host Controller Interface (EHCI) Specification, Version 1.0, and the Open Host Controller Interface (OHCI) Specification, Version 1.0a.

2.1.9.2. EMAC

- Support 10/100/1000Mbps data transfer rate
- Support RGMII/RMII interface
- Support full-duplex and half-duplex operation
- Support linked-list descriptor list structure
- Programmable frame length to support Standard or Jumbo Ethernet frames with sizes up to 16 KB
- Supports a variety of flexible address filtering modes

2.1.9.3. UART

- Up to six UART controllers
- Two of six UART controllers support 2-wire while others support 4-wire
- 64-Bytes Transmit and receive data FIFOs for all UART
- Compatible with industry-standard 16550 UARTs
- Support Infrared Data Association (IrDA) 1.0 SIR
- Support speed up to 3MHz

2.1.9.4. SPI

- Up to two SPI controllers

- Full-duplex synchronous serial interface
- Master/Slave configurable
- Mode0~3 are supported for both transmit and receive operations
- Two 64-Bytes FIFO for SPI-TX and SPI-RX operation
- DMA-based or interrupt-based operation
- Polarity and phase of the chip select(SPI_SS) and SPI_Clock(SPI_SCLK) are configurable
- Support single and dual IO mode

2.1.9.5. Two Wire Interface(TWI)

- Up to four TWI controllers
- Support Standard mode(up to 100K bps) and Fast mode(up to 400K bps)
- Master/Slave configurable
- Allows 10-bit addressing transactions
- Perform arbitration and clock synchronization
- Allow operation from a wide range of input clock frequencies

2.1.9.6. CIR

- A flexible receiver for IR remote
- Programmable FIFO threshold
- 64x8bits FIFO for data buffer

2.1.9.7. Reduced Serial Bus(RSB™)

- Up to 20MHz speed with ultra low power
- Support push-pull bus
- Support host mode and multi-devices
- Programmable output delay of CD signal
- Support parity check for address and data transmission

2.1.9.8. TS

- Compliant with the industry-standard AMBA Host Bus(AHB) Specification, Revision 2.0.Support 32-bit Little Endian bus.
- Support DVB-CSA V1.1 Descrambler
- One external Synchronous Parallel Interface(SPI) or one external Synchronous Serial Interface(SS1)
- Configurable SPI and SS1 timing parameters
- Hardware packet synchronous byte error detecting

- Hardware PCR packet detecting

2.1.9.9. SCR

- Supports APB slave interface for easy integration with AMBA-based host systems
- Supports the ISO/IEC 7816-3:1997(E) and EMV2000 (4.0) Specifications
- Supports adjustable clock rate and bit rate
- Configurable automatic byte repetition
- Support asynchronous half-duplex character transmission and block transmission
- Supports synchronous and any other non-ISO 7816 and non-EMV cards
- Performs functions needed for complete smart card sessions, including:
 - Card activation and deactivation
 - Cold/warm reset
 - Answer to Reset (ATR) response reception
 - Data transfers to and from the card

2.1.10. Package

- FBGA 396 balls, 0.65mm ball pitch, 15 x 15mm

2.2. System Block Diagram

The following figure shows the block diagram of A64 processor.

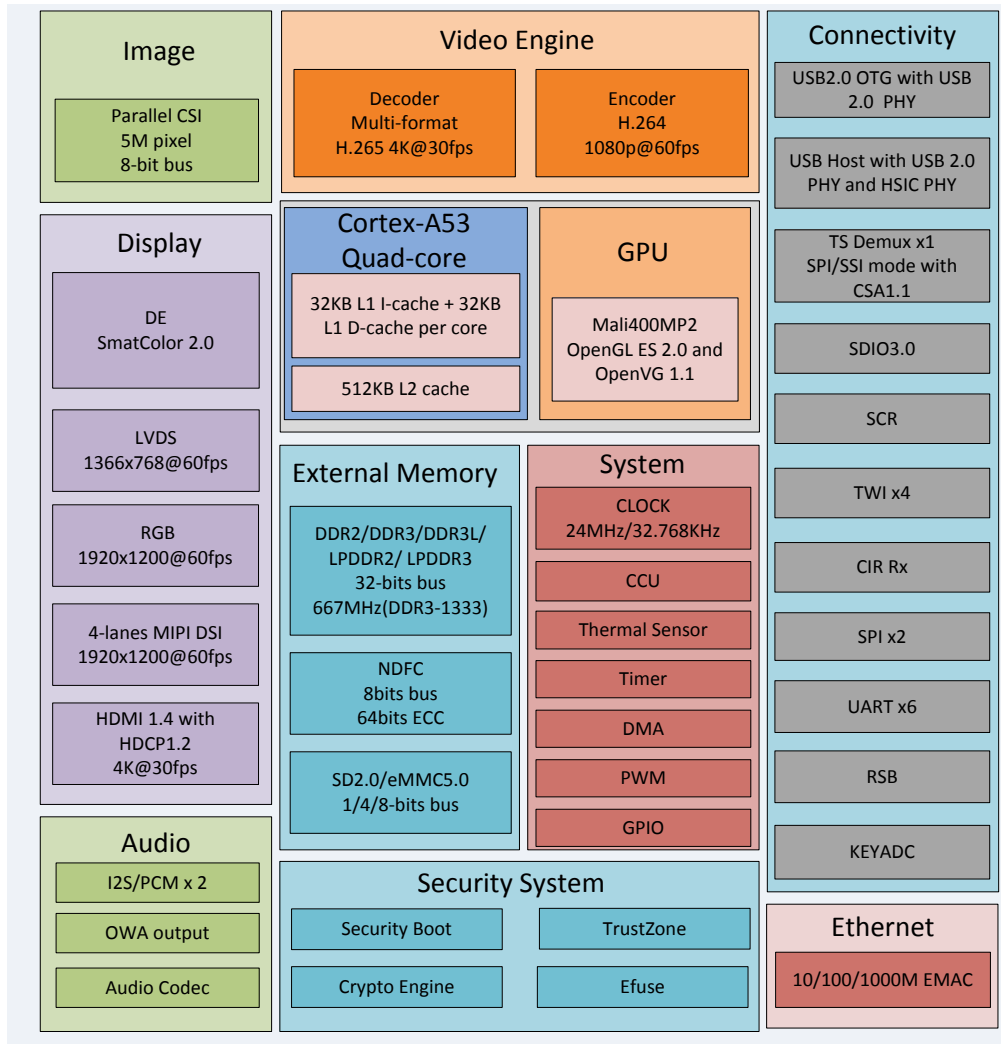

Figure 2-1. A64 Block Diagram

Chapter 3 System

The chapter describes the A64 system from following sections:

- [Memory Mapping](#)
- [Boot System](#)
- [CCU](#)
- [CPU Configuration](#)
- [System Control](#)
- [Timer](#)
- [R_Trusted Watchdog Timer](#)
- [RTC](#)
- [High-speed Timer](#)
- [PWM](#)
- [DMA](#)
- [GIC](#)
- [Message Box](#)
- [Spinlock](#)
- [Crypto Engine](#)
- [Secure Memory Controller](#)
- [Secure Peripherals Controller](#)
- [Thermal Sensor Controller](#)
- [KEYADC](#)
- [Audio Codec](#)
- [Port Controller\(CPUx-PORT\)](#)
- [Port Controller\(CPUs-PORT\)](#)

3.1. Memory Mapping

Module	Address (It is for Cluster CPU)	Size (byte)
N-BROM	0x0000 0000---0x0000 BFFF	48K
S-BROM	0x0000 0000---0x0000 FFFF	64K
SRAM A1	0x0001 0000---0x0001 7FFF	32K
SRAM A2	0x0004 4000---0x0005 3FFF	64K
SRAM C	0x0001 8000---0x0003 FFFF	160K
DE	0x0100 0000---0x013F FFFF	4M
Core Sight Debug	0x0140 0000---0x0141 FFFF	128K
CPU MBIST	0x0150 2000---0x0150 2FFF	4K
CPUX_CFG	0x0170 0000---0x0170 03FF	1K
System Control	0x01C0 0000---0x01C0 0FFF	4K
DMA	0x01C0 2000---0x01C0 2FFF	4K
NFDC	0x01C0 3000---0x01C0 3FFF	4K
TS	0x01C0 6000---0x01C0 6FFF	4K
Key Memory Space	0x01C0 B000---0x01C0 BFFF	4K
TCON 0	0x01C0 C000---0x01C0 CFFF	4K
TCON 1	0x01C0 D000---0x01C0 DFFF	4K
VE	0x01C0 E000---0x01C0 EFFF	4K
SMHC 0	0x01C0 F000---0x01C0 FFFF	4K
SMHC 1	0x01C1 0000---0x01C1 0FFF	4K
SMHC 2	0x01C1 1000---0x01C1 1FFF	4K
SID	0x01C1 4000---0x01C1 43FF	1K
Crypto Engine	0x01C1 5000---0x01C1 5FFF	4K
MSG_BOX	0x01C1 7000---0x01C1 7FFF	4K
SPINLOCK	0x01C1 8000---0x01C1 8FFF	4K
USB-OTG-Device	0x01C1 9000---0x01C1 9FFF	4K
USB-OTG-EHCI/OHCI	0x01C1 A000---0x01C1 AFFF	4K
USB-EHCI0/OHCI0	0x01C1 B000---0x01C1 BFFF	4K
SMC	0x01C1 E000---0x01C1 EFFF	4K
CCU	0x01C2 0000---0x01C2 03FF	1K
PIO	0x01C2 0800---0x01C2 0BFF	1K
TIMER	0x01C2 0C00---0x01C2 0FFF	1K
OWA	0x01C2 1000---0x01C2 13FF	1K
PWM	0x01C2 1400---0x01C2 17FF	1K
KEYADC	0x01C2 1800---0x01C2 1BFF	1K
I2S/PCM 0	0x01C2 2000---0x01C2 23FF	1K
I2S/PCM 1	0x01C2 2400---0x01C2 27FF	1K

I2S/PCM 2	0x01C2 2800---0x01C2 2BFF	1K
AC	0x01C2 2C00---0x01C2 33FF	2K
SPC	0x01C2 3400---0x01C2 37FF	1K
THS	0x01C2 5000---0x01C2 53FF	1K
UART 0	0x01C2 8000---0x01C2 83FF	1K
UART 1	0x01C2 8400---0x01C2 87FF	1K
UART 2	0x01C2 8800---0x01C2 8BFF	1K
UART 3	0x01C2 8C00---0x01C2 8FFF	1K
UART 4	0x01C2 9000---0x01C2 93FF	1K
TWI 0	0x01C2 AC00---0x01C2 AFFF	1K
TWI 1	0x01C2 B000---0x01C2 B3FF	1K
TWI 2	0x01C2 B400---0x01C2 B7FF	1K
SCR	0x01C2 C400---0x01C2 C7FF	1K
EMAC	0x01C3 0000---0x01C3 FFFF	64K
GPU	0x01C4 0000---0x01C4 FFFF	64K
HSTMR	0x01C6 0000---0x01C6 0FFF	4K
DRAMCOM	0x01C6 2000---0x01C6 2FFF	4K
DRAMCTLO	0x01C6 3000---0x01C6 3FFF	4K
DRAMPHY0	0x01C6 5000---0x01C6 5FFF	4K
SPIO	0x01C6 8000---0x01C6 8FFF	4K
SPI1	0x01C6 9000---0x01C6 9FFF	4K
SCU space, CPUS can't access	0x01C80000 GIC_DIST: 0x01C80000 + 0x1000 GIC_CPUIF:0x01C80000 + 0x2000	
MIPI DSI	0x01CA 0000---0x01CA 0FFF	4K
MIPI DSI-PHY	0x01CA 1000---0x01CA 1FFF	4K
CSI	0x01CB 0000---0x01CF FFFF	320K
De-interlaced	0x01E0 0000---0x01E1 FFFF	128K
HDMI	0x01EE 0000---0x01EF FFFF	128K
RTC	0x01F0 0000---0x01F0 03FF	1K
R_TIMER	0x01F0 0800---0x01F0 0BFF	1K
R_INTC	0x01F0 0C00---0x01F0 0FFF	1K
R_WDOG	0x01F0 1000---0x01F0 13FF	1K
R_PRCM	0x01F0 1400---0x01F0 17FF	1K
R_TWD	0x01F0 1800---0x01F0 1BFF	1K
R_CPUCFG	0x01F0 1C00---0x01F0 1FFF	1K
R_CIR-RX	0x01F0 2000---0x01F0 23FF	1K
R_TWI	0x01F0 2400---0x01F0 27FF	1K
R_UART	0x01F0 2800---0x01F0 2BFF	1K

R_PIO	0x01F0 2C00---0x01F0 2FFF	1K
R_RSB	0x01F0 3400---0x01F0 37FF	1K
R_PWM	0x01F0 3800---0x01F0 3BFF	1K
SDRAM	0x4000 0000---0xFFFF FFFF	3G

3.2. Boot System

The system will boot in different ways based on whether its security features are enabled.

The Boot System includes the following features:

- Support CPU-0 boot process and CPU-0+ boot process
- Support super standby wakeup process
- Support mandatory upgrade process through SDC0 and USB OTG
- Support fast boot process from Raw NAND,eMMC,SD/TF card ,and SPI NOR Flash

3.3. CCU

3.3.1. Overview

The CCU controls the PLLs configuration and most of the clock generation, division, distribution, synchronization and gating. CCU input signals include the external clock for the reference frequency (24MHz). The outputs from CCU are mostly clocks to other blocks in the system.

The CCU includes the following features:

- 13 PLLs, independent PLL for CPUX
- Bus Source and Divisions
- PLLs Bias Control
- PLLs Tuning Control
- PLLs Pattern Control
- Configuring Modules Clock
- Bus Clock Gating
- Bus Software Reset

3.3.2. Functionalities Description

3.3.2.1. System Bus

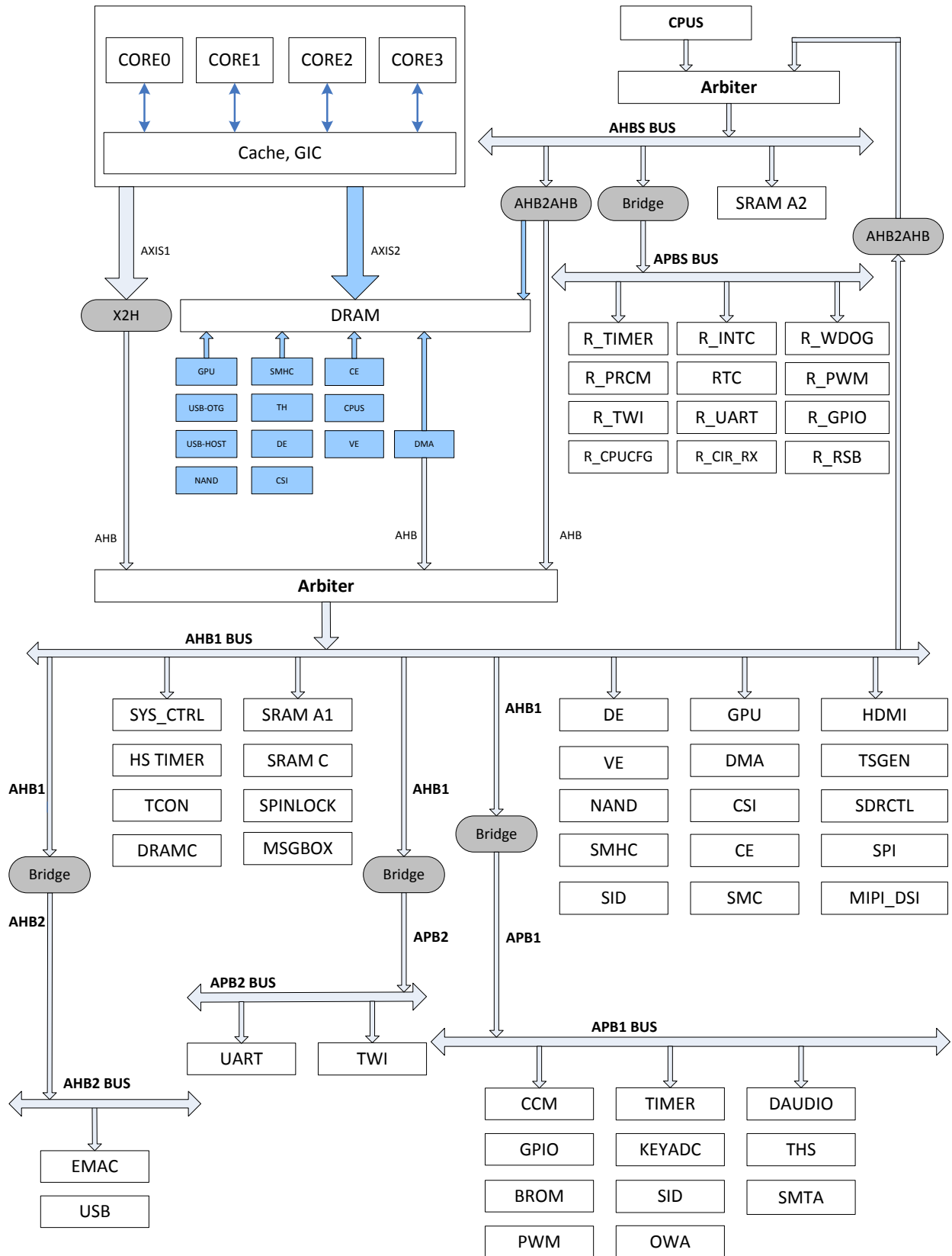

Figure 3-1. System Bus Tree

3.3.2.2. Bus clock tree

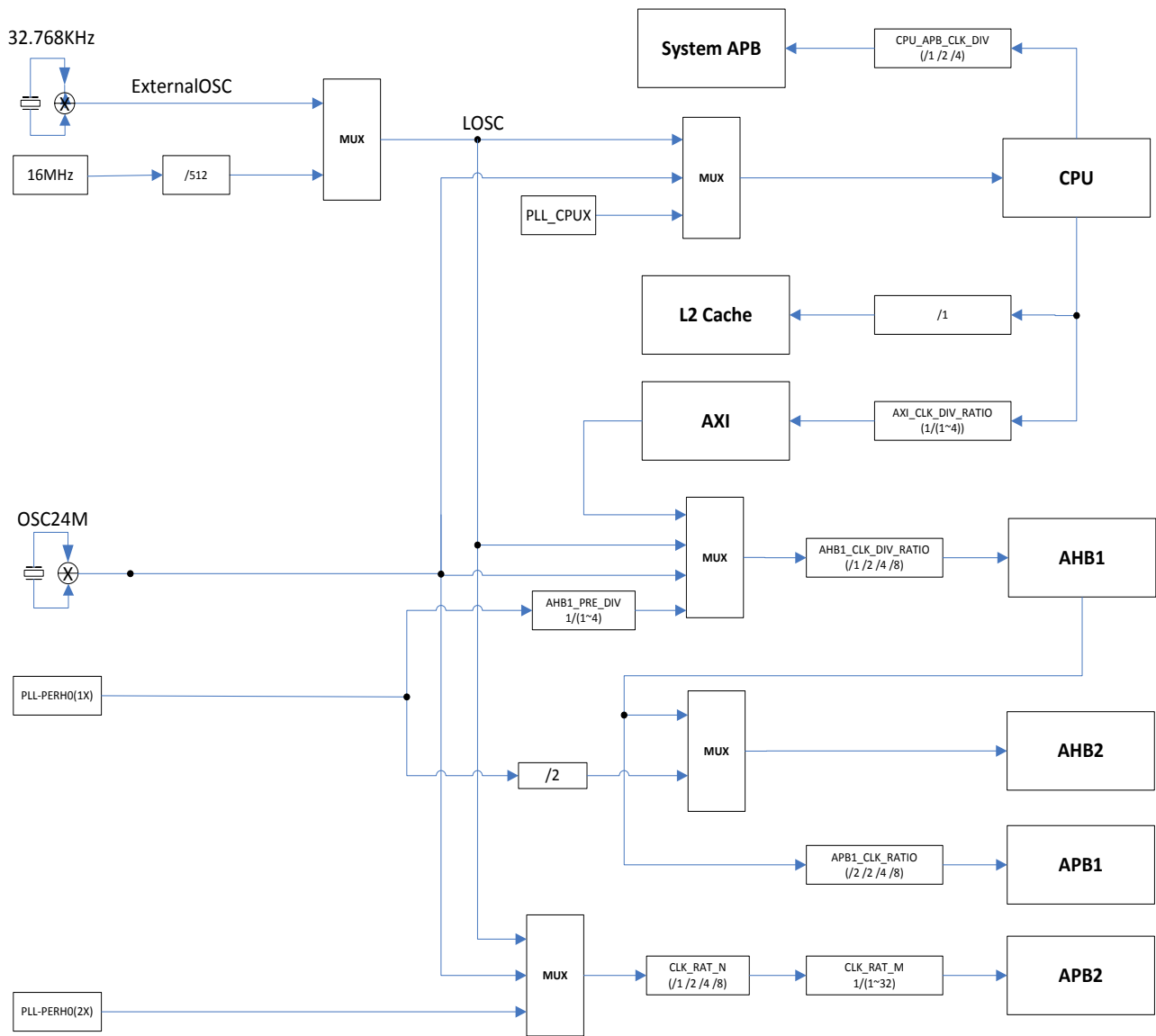

Figure 3-2. Bus Clock Tree

3.3.2.3. Module clock tree

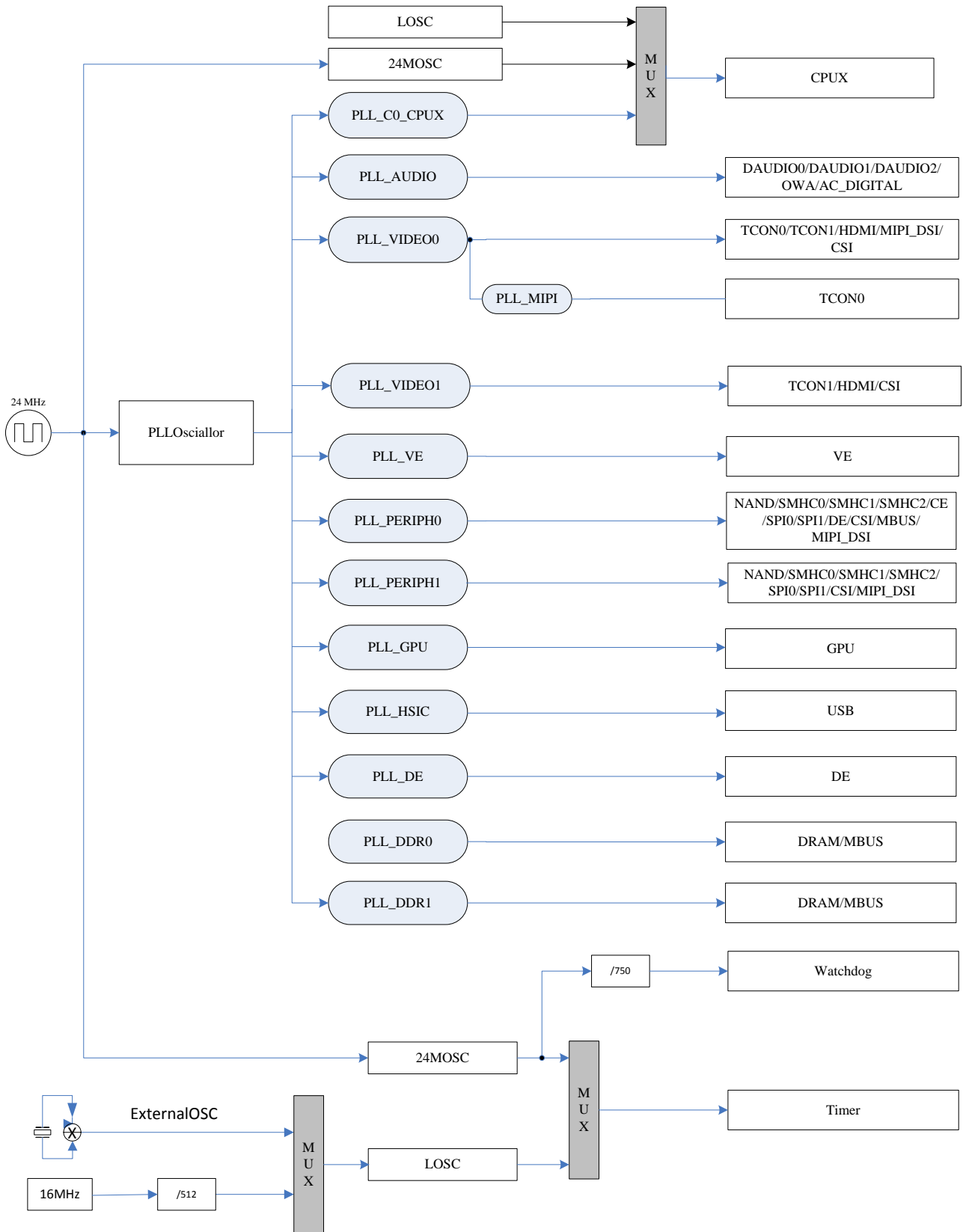

Figure 3-3. Module Clock Diagram

3.3.3. Typical Applications

- (1). Clock output of **PLL_CPUX** is used only for CPU;and the frequency factor can be dynamically modified for DVFS;
- (2). Clock output of **PLL_AUDIO** (24.571MHz or 24.5792MHz)can be used for I2S/PCM 0,I2S/PCM 1,I2S/PCM 2, AC DIGITAL,OWA ;and dynamic frequency scaling is not supported;
- (3). Clock output of **PLL_VIDEO0** (1X) can be used for TCON1,HDMI,MIPI_DSI;clock output of **PLL_VIDEO0** (2X) can be used for TCON0;dynamic frequency scaling is not supported for **PLL_VIDEO0**(1X) and **PLL_VIDEO0**(2X);
- (4). Clock output of **PLL_VIDEO1** (1X) can be used for TCON1,HDMI,CSI; and dynamic frequency scaling is not supported;
- (5). Clock output of **PLL_VE** can be only used for VE;and dynamic frequency scaling is not supported;
- (6). Clock output of **PLL_DDR0** can be used for MBUS and DRAM;and dynamic frequency scaling is not supported;
- (7). Clock output of **PLL_PERIPH0** (2X) can be used for APB2,MBUS,SMHC0,SMHC1,SMHC2,CE,DE; Clock output of **PLL_PERIPH0**(1X) can be used for AHB1,APB1,AHB2,MBUS and NAND,SPI0,SPI1,CSI,MIPI_DSI,De-interlace, CPU; dynamic frequency scaling is not supported for **PLL_PERIPH0**(2X) and **PLL_PERIPH0**(1X);
- (8). Clock output of **PLL_PERIPH1**(2X) can be used for SMHC0,SMHC1,SMHC2,CE;Clock output of **PLL_PERIPH1**(1X) can be used for NAND,SPI0,SPI1,CSI,MIPI_DSI,De-interlace;dynamic frequency scaling is not supported for **PLL_PERIPH1**(2X) and **PLL_PERIPH1**(1X);
- (9). Clock output of **PLL_GPU** can be used for GPU;and dynamic frequency scaling is not supported;
- (10). Clock output of **PLL_MIPI** can be used for TCON0;and dynamic frequency scaling is not supported;
- (11). Clock output of **PLL_HSIC** can be used for USB;and dynamic frequency scaling is not supported;
- (12). Clock output of **PLL_DE** can be used for DE;and dynamic frequency scaling is not supported;
- (13). Clock output of **PLL_DDR1** can be used for MBUS and DRAM;and dynamic frequency scaling is not supported;

3.3.4. Register List

Module Name	Base Address
CCU	0x01C20000

Register Name	Offset	Description
PLL_CPUX_CTRL_REG	0x0000	PLL_CPUX Control Register
PLL_AUDIO_CTRL_REG	0x0008	PLL_AUDIO Control Register
PLL_VIDEO0_CTRL_REG	0x0010	PLL_VIDEO0 Control Register
PLL_VE_CTRL_REG	0x0018	PLL_VE Control Register
PLL_DDR0_CTRL_REG	0x0020	PLL_DDR0 Control Register
PLL_PERIPH0_CTRL_REG	0x0028	PLL_PERIPH0 Control Register
PLL_PERIPH1_CTRL_REG	0x002C	PLL_PERIPH1 Control Register
PLL_VIDEO1_CTRL_REG	0x0030	PLL_VIDEO1 Control Register
PLL_GPU_CTRL_REG	0x0038	PLL_GPU Control Register
PLL_MIPI_CTRL_REG	0x0040	PLL_MIPI Control Register

PLL_HSIC_CTRL_REG	0x0044	PLL_HSIC Control Register
PLL_DE_CTRL_REG	0x0048	PLL_DE Control Register
PLL_DDR1_CTRL_REG	0x004C	PLL_DDR1 Control Register
CPU_AXI_CFG_REG	0x0050	CPUX/AXI Configuration Register
AHB1_APB1_CFG_REG	0x0054	AHB1/APB1 Configuration Register
APB2_CFG_REG	0x0058	APB2 Configuration Register
AHB2_CFG_REG	0x005C	AHB2 Configuration Register
BUS_CLK_GATING_REG0	0x0060	Bus Clock Gating Register 0
BUS_CLK_GATING_REG1	0x0064	Bus Clock Gating Register 1
BUS_CLK_GATING_REG2	0x0068	Bus Clock Gating Register 2
BUS_CLK_GATING_REG3	0x006C	Bus Clock Gating Register 3
BUS_CLK_GATING_REG4	0x0070	Bus Clock Gating Register 4
THS_CLK_REG	0x0074	THS Clock Register
NAND_CLK_REG	0x0080	NAND Clock Register
SDMMC0_CLK_REG	0x0088	SDMMC0 Clock Register
SDMMC1_CLK_REG	0x008C	SDMMC1 Clock Register
SDMMC2_CLK_REG	0x0090	SDMMC2 Clock Register
TS_CLK_REG	0x0098	TS Clock Register
CE_CLK_REG	0x009C	CE Clock Register
SPI0_CLK_REG	0x00A0	SPI0 Clock Register
SPI1_CLK_REG	0x00A4	SPI1 Clock Register
I2S/PCM-0_CLK_REG	0x00B0	I2S/PCM-0 Clock Register
I2S/PCM-1_CLK_REG	0x00B4	I2S/PCM-1 Clock Register
I2S/PCM-2_CLK_REG	0x00B8	I2S/PCM-2 Clock Register
SPDIF_CLK_REG	0x00C0	SPDIF Clock Register
USBPHY_CFG_REG	0x00CC	USBPHY Configuration Register
DRAM_CFG_REG	0x00F4	DRAM Configuration Register
PLL_DDR_CFG_REG	0x00F8	PLL_DDR Configuration Register
MBUS_RST_REG	0x00FC	MBUS Reset Register
DRAM_CLK_GATING_REG	0x0100	DRAM Clock Gating Register
DE_CLK_REG	0x0104	DE Clock Register
TCON0_CLK_REG	0x0118	TCON0 Clock Register
TCON1_CLK_REG	0x011C	TCON1 Clock Register
DEINTERLACE_CLK_REG	0x0124	DEINTERLACE Clock Register
CSI_MISC_CLK_REG	0x0130	CSI_MISC Clock Register
CSI_CLK_REG	0x0134	CSI Clock Register
VE_CLK_REG	0x013C	VE Clock Register
AC_DIG_CLK_REG	0x0140	AC Digital Clock Register
AVS_CLK_REG	0x0144	AVS Clock Register
HDMI_CLK_REG	0x0150	HDMI Clock Register
HDMI_SLOW_CLK_REG	0x0154	HDMI Slow Clock Register

MBUS_CLK_REG	0x015C	MBUS Clock Register
MIPI_DSI_CLK_REG	0x0168	MIPI_DSI Clock Register
GPU_CLK_REG	0x01A0	GPU Clock Register
PLL_STABLE_TIME_REG0	0x0200	PLL Stable Time Register0
PLL_STABLE_TIME_REG1	0x0204	PLL Stable Time Register1
PLL_PERIPH1_BIAS_REG	0x021C	PLL_PERIPH1 Bias Register
PLL_CPUX_BIAS_REG	0x0220	PLL_CPUX Bias Register
PLL_AUDIO_BIAS_REG	0x0224	PLL_AUDIO Bias Register
PLL_VIDEO0_BIAS_REG	0x0228	PLL_VIDEO0 Bias Register
PLL_VE_BIAS_REG	0x022C	PLL_VE Bias Register
PLL_DDR0_BIAS_REG	0x0230	PLL_DDR0 Bias Register
PLL_PERIPH0_BIAS_REG	0x0234	PLL_PERIPH0 Bias Register
PLL_VIDEO1_BIAS_REG	0x0238	PLL_VIDEO1 Bias Register
PLL_GPU_BIAS_REG	0x023C	PLL_GPU Bias Register
PLL_MIPI_BIAS_REG	0x0240	PLL_MIPI Bias Register
PLL_HSIIC_BIAS_REG	0x0244	PLL_HSIIC Bias Register
PLL_DE_BIAS_REG	0x0248	PLL_DE Bias Register
PLL_DDR1_BIAS_REG	0x024C	PLL_DDR1 Bias Register
PLL_CPUX_TUN_REG	0x0250	PLL_CPUX Tuning Register
PLL_DDR0_TUN_REG	0x0260	PLL_DDR0 Tuning Register
PLL_MIPI_TUN_REG	0x0270	PLL_MIPI Tuning Register
PLL_PERIPH1_PAT_CTRL_REG	0x027C	PLL_PERIPH1 Pattern Control Register
PLL_CPUX_PAT_CTRL_REG	0x0280	PLL_CPUX Pattern Control Register
PLL_AUDIO_PAT_CTRL_REG	0x0284	PLL_AUDIO Pattern Control Register
PLL_VIDEO0_PAT_CTRL_REG	0x0288	PLL_VIDEO0 Pattern Control Register
PLL_VE_PAT_CTRL_REG	0x028C	PLL_VE Pattern Control Register
PLL_DDR0_PAT_CTRL_REG	0x0290	PLL_DDR0 Pattern Control Register
PLL_VIDEO1_PAT_CTRL_REG	0x0298	PLL_VIDEO1 Pattern Control Register
PLL_GPU_PAT_CTRL_REG	0x029C	PLL_GPU Pattern Control Register
PLL_MIPI_PAT_CTRL_REG	0x02A0	PLL_MIPI Pattern Control Register
PLL_HSIIC_PAT_CTRL_REG	0x02A4	PLL_HSIIC Pattern Control Register
PLL_DE_PAT_CTRL_REG	0x02A8	PLL_DE Pattern Control Register
PLL_DDR1_PAT_CTRL_REG0	0x02AC	PLL_DDR1 Pattern Control Register0
PLL_DDR1_PAT_CTRL_REG1	0x02B0	PLL_DDR1 Pattern Control Register1
BUS_SOFT_RST_REG0	0x02C0	Bus Software Reset Register 0
BUS_SOFT_RST_REG1	0x02C4	Bus Software Reset Register 1
BUS_SOFT_RST_REG2	0x02C8	Bus Software Reset Register 2
BUS_SOFT_RST_REG3	0x02D0	Bus Software Reset Register 3
BUS_SOFT_RST_REG4	0x02D8	Bus Software Reset Register 4

CCM_SEC_SWITCH_REG	0x02F0	CCM Security Switch Register
PS_CTRL_REG	0x0300	PS Control Register
PS_CNT_REG	0x0304	PS Counter Register
PLL_LOCK_CTRL_REG	0x0320	PLL Lock Control Register

3.3.5. Register Description

3.3.5.1. PLL_CPUX Control Register (Default Value: 0x00001000)

Offset: 0x0000			Register Name: PLL_CPUX_CTRL_REG
Bit	R/W	Default/Hex	Description
31	R/W	0x0	<p>PLL_ENABLE.</p> <p>0: Disable</p> <p>1: Enable</p> <p>The PLL Output= (24MHz*N*K)/(M*P).</p> <p>The PLL output is for the CPUX Clock.</p> <p>Note: $10 \leq N * K \leq 88$, The P factor only can be used when PLL output frequency is less than 240MHz.</p> <p>The PLL output clock must be in the range of 240MHz~2.1GHz.</p> <p>The default of CPUX Clock is 408MHz.</p>
30:29	/	/	/
28	R	0x0	<p>LOCK</p> <p>0: Unlocked</p> <p>1: Locked (It indicates that the PLL has been stable.)</p>
27:25	/	/	/
24	R/W	0x0	<p>CPUX_SDM_EN.</p> <p>0: Disable</p> <p>1: Enable</p>
23:18	/	/	/
17:16	R/W	0x0	<p>PLL_OUT_EXT_DIVP</p> <p>PLL Output external divider P</p> <p>00: /1</p> <p>01: /2</p> <p>10: /4</p> <p>11: /</p>
15:13	/	/	/
12:8	R/W	0x10	<p>PLL_FACTOR_N</p> <p>PLL Factor N.</p> <p>Factor=0, N=1</p> <p>Factor=1, N=2</p> <p>Factor=2, N=3</p>

		 Factor=31, N=32
7:6	/	/	/
5:4	R/W	0x0	PLL_FACTOR_K. PLL Factor K.(K=Factor + 1) The range is from 1 to 4.
3:2	/	/	/
1:0	R/W	0x0	PLL_FACTOR_M. PLL Factor M. (M=Factor + 1) The range is from 1 to 4.

3.3.5.2. PLL_Audio Control Register (Default Value: 0x00035514)

Offset: 0x0008			Register Name: PLL_AUDIO_CTRL_REG
Bit	R/W	Default/Hex	Description
31	R/W	0x0	PLL_ENABLE. 0: Disable 1: Enable. The PLL is for Audio. The PLL_AUDIO= (24MHz*N)/(M*P). The PLL_AUDIO(8X) = (24MHz*N*2)/M Note: $3 \leq N/M \leq 21$. (24MHz*N)/P must be in the range of 72MHz~504MHz. PLL_AUDIO default is 24.571MHz.
30:29	/	/	/
28	R	0x0	LOCK. 0: Unlocked 1: Locked (It indicates that the PLL has been stable.)
27:25	/	/	/
24	R/W	0x0	PLL_SDM_EN. 0: Disable 1: Enable. In this case, the PLL_FACTOR_N only low 4 bits are valid (N: The range is from 1 to 16).
23:20	/	/	/
19:16	R/W	0x3	PLL_POSTDIV_P. Post-div factor (P= Factor+1) The range is from 1 to 16.
14:8	R/W	0x55	PLL_FACTOR_N. PLL Factor N. Factor=0, N=1

			Factor=1, N=2 Factor=127, N=128.
7:5	/	/	/
4:0	R/W	0x14	PLL_PREDIV_M. PLL Pre-div Factor(M = Factor+1). The range is from 1 to 32.

3.3.5.3. PLL_VIDEO0 Control Register (Default Value: 0x03006207)

Offset: 0x0010			Register Name: PLL_VIDEO0_CTRL_REG
Bit	R/W	Default/Hex	Description
31	R/W	0x0	PLL_ENABLE. 0: Disable 1: Enable. In the integer mode, $PLL_VIDEO0(1X) = (24MHz * N) / M$. $PLL_VIDEO0(2X) = ((24MHz * N) / M) * 2$. In the fractional mode, the PLL Output is select by bit 25. Note: $8 \leq N/M \leq 25$ $(24MHz * N) / M$ must be in the range of 192MHz~600MHz. PLL_VIDEO0(1X) default is 297MHz.
30	R/W	0x0	PLL_MODE. 0: Manual Mode 1: Auto Mode (Controlled by DE).
29	/	/	/
28	R	0x0	LOCK. 0: Unlocked 1: Locked (It indicates that the PLL has been stable.)
27:26	/	/	/
25	R/W	0x1	FRAC_CLK_OUT. PLL clock output when PLL_MODE_SEL=0(PLL_PREDIV_M factor must be set to 0); No meaning when PLL_MODE_SEL =1. 0: PLL Output=270MHz 1: PLL Output =297MHz.
24	R/W	0x1	PLL_MODE_SEL. 0: Fractional Mode 1: Integer Mode. Note: When in Fractional mode, the Per Divider M should be set to 0.
23:21	/	/	/
20	R/W	0x0	PLL_SDM_EN. 0: Disable 1: Enable.

19:15	/	/	/
14:8	R/W	0x62	PLL_FACTOR_N. PLL Factor N. Factor=0, N=1 Factor=1, N=2 Factor=2, N=3 Factor=127,N=128.
7:4	/	/	/
3:0	R/W	0x7	PLL_PREDIV_M. PLL Pre-div Factor(M = Factor+1). The range is from 1 to 16.

3.3.5.4. PLL_VE Control Register (Default Value: 0x03006207)

Offset: 0x0018			Register Name: PLL_VE_CTRL_REG
Bit	R/W	Default/Hex	Description
31	R/W	0x0	PLL_ENABLE. 0: Disable 1: Enable. In the integer mode, The PLL_VE = (24MHz*N)/M. In the fractional mode, the PLL Output is select by bit 25. Note: $8 \leq N/M \leq 25$ (24MHz*N)/M must be in the range of 192MHz~600MHz. PLL_VE default is 297MHz.
30:29	/	/	/
28	R	0x0	LOCK 0: Unlocked 1: Locked (It indicates that the PLL has been stable.)
27:26	/	/	/
25	R/W	0x1	FRAC_CLK_OUT. PLL clock output when PLL_MODE_SEL=0(PLL_PREDIV_M factor must be set to 0); No meaning when PLL_MODE_SEL =1. 0: PLL Output=270MHz 1: PLL Output =297MHz.
24	R/W	0x1	PLL_MODE_SEL. 0: Fractional Mode 1: Integer Mode. Note: When in Fractional mode, the Per Divider M should be set to 0.
23:21	/	/	/
20	R/W	0x0	PLL_SDM_EN. 0: Disable 1: Enable.

19:15	/	/	/
14:8	R/W	0x62	PLL_FACTOR_N. PLL Factor N. Factor=0, N=1 Factor=1, N=2 Factor=2, N=3 Factor=31,N=32 ... Factor=127,N=128.
7:4	/	/	/
3:0	R/W	0x7	PLL_PREDIV_M. PLL Pre Divider (M = Factor+1). The range is from 1 to 16.

3.3.5.5. PLL_DDR0 Control Register (Default Value: 0x00001000)

Offset: 0x0020			Register Name: PLL_DDR0_CTRL_REG
Bit	R/W	Default/Hex	Description
31	R/W	0x0	PLL_ENABLE. 0: Disable 1: Enable. The PLL_DDR0 = (24MHz*N*K)/M. Note: $10 \leq N * K \leq 77$ (give priority to the choice of $K \geq 2$) (24MHz*N*K) must be in the range of 240MHz~1.8GHz. PLL_DDR0 default is 408MHz.
30:29	/	/	/
28	R	0x0	LOCK 0: Unlocked 1: Locked (It indicates that the PLL has been stable.)
27:25	/	/	/
24	R/W	0x0	PLL_SDM_EN. 0: Disable 1: Enable.
23:21	/	/	/
20	R/W	0x0	PLL_DDR0_CFG_UPDATE. PLL_DDR0 Configuration Update. When PLL_DDR0 has been changed, this bit should be set to 1 to validate the PLL, otherwise the change would be invalid. And this bit would be cleared automatically after the PLL change is valid. 0: No effect 1: Validating the PLL_DDR0.
19:13	/	/	/

12:8	R/W	0x10	PLL_FACTOR_N. PLL Factor N. Factor=0, N=1 Factor=1, N=2 Factor=2, N=3 Factor=31,N=32.
7:6	/	/	/
5:4	R/W	0x0	PLL_FACTOR_K. PLL Factor K.(K=Factor + 1) The range is from 1 to 4.
3:2	/	/	/
1:0	R/W	0x0	PLL_FACTOR_M. PLL Factor M.(M = Factor + 1) The range is from 1 to 4.

3.3.5.6. PLL_PERIPH0 Control Register (Default Value: 0x00041811)

Offset: 0x0028			Register Name: PLL_PERIPH0_CTRL_REG
Bit	R/W	Default/Hex	Description
31	R/W	0x0	PLL_ENABLE. 0: Disable 1: Enable. The PLL_PERIPH0(1X) = 24MHz*N*K/2. The PLL_PERIPH0(2X) = 24MHz*N*K. Note: $21 \leq N * K \leq 58$ (give priority to the choice of $K \geq 2$) The PLL_PERIPH0(2X) should be fixed to 1.2GHz, it is not recommended to vary this value arbitrarily. 24MHz*N*K clock must be in the range of 504MHz~1.4GHz. PLL_PERIPH0(2X) default is 1.2GHz.
30:29	/	/	/
28	R	0x0	LOCK. 0: Unlocked 1: Locked (It indicates that the PLL has been stable.)
27:26	/	/	/
25	R/W	0x0	PLL_BYPASS_EN. PLL Output Bypass Enable. 0: Disable 1: Enable If the bypass is enabled, the PLL output is 24MHz.
24	R/W	0x0	PLL_CLK_OUT_EN. PLL clock output enable. 0: Disable

			1: Enable
23:19	/	/	/
18	R/W	0x1	PLL_24M_OUT_EN. PLL 24MHz Output Enable. 0: Disable 1: Enable When 25MHz crystal used, this PLL can output 24MHz.
17:16	R/W	0x0	PLL_24M_POST_DIV. PLL 24M Output Clock Post Divider (When 25MHz crystal used). 1/2/3/4.
15:13	/	/	/
12:8	R/W	0x18	PLL_FACTOR_N. PLL Factor N. Factor=0, N=1 Factor=1, N=2 Factor=2, N=3 Factor=31, N=32
7:6	/	/	/
5:4	R/W	0x1	PLL_FACTOR_K. PLL Factor K.(K=Factor + 1) The range is from 1 to 4.
3:2	/	/	/
1:0	R/W	0x1	PLL_FACTOR_M. PLL Factor M (M = Factor + 1) is only valid in plltest debug. The PLL_PERIPH back door clock output =24MHz*N*K/M. The range is from 1 to 4.

3.3.5.7. PLL_PERIPH1 Control Register (Default Value: 0x00041811)

Offset: 0x002C			Register Name: PLL_PERIPH1_CTRL_REG
Bit	R/W	Default/Hex	Description
31	R/W	0x0	PLL_ENABLE. 0: Disable 1: Enable. The PLL_PERIPH0(1X) = 24MHz*N*K/2. The PLL_PERIPH0(2X) = 24MHz*N*K. Note: 21 ≤ N*K ≤ 58(give priority to the choice of K ≥ 2) The PLL_PERIPH1(2X) should be fixed to 1.2GHz, it is not recommended to vary this value arbitrarily. 24MHz*N*K clock must be in the range of 504MHz~1.4GHz. PLL_PERIPH0(2X) default is 1.2GHz.
30:29	/	/	/

28	R	0x0	LOCK. 0: Unlocked 1: Locked (It indicates that the PLL has been stable.)
27:26	/	/	/
25	R/W	0x0	PLL_BYPASS_EN. PLL Output Bypass Enable. 0: Disable 1: Enable. If the bypass is enabled, the PLL output is 24MHz.
24	R/W	0x0	PLL_CLK_OUT_EN. PLL clock output enable.(Just for the SATA Phy) 0: Disable 1: Enable.
23:21	/	/	/
20	R/W	0x0	PLL_SDM_EN 0: Disable 1: Enable.
19	/	/	/
18	R/W	0x1	PLL_24M_OUT_EN. PLL 24MHz Output Enable. 0: Disable 1: Enable. When 25MHz crystal used, this PLL can output 24MHz.
17:16	R/W	0x0	PLL_24M_POST_DIV. PLL 24M Output Clock Post Divider (When 25MHz crystal used). 1/2/3/4.
15:13	/	/	/
12:8	R/W	0x18	PLL_FACTOR_N. PLL Factor N. Factor=0, N=1 Factor=1, N=2 Factor=2, N=3 Factor=31,N=32.
7:6	/	/	/
5:4	R/W	0x1	PLL_FACTOR_K. PLL Factor K.(K=Factor + 1) The range is from 1 to 4.
3:2	/	/	/
1:0	R/W	0x1	PLL_FACTOR_M. PLL Factor M (M = Factor + 1) is only valid in plltest debug. The PLL_PERIPH back door clock output =24MHz*N*K/M. The range is from 1 to 4.

3.3.5.8. PLL_VIDEO1 Control Register (Default Value: 0x03006207)

Offset: 0x0030			Register Name: PLL_VIDEO1_CTRL_REG
Bit	R/W	Default/Hex	Description
31	R/W	0x0	PLL_ENABLE. 0: Disable 1: Enable. In the integer mode, $PLL_VIDEO1(1X) = (24MHz * N) / M$. $PLL_VIDEO1(2X) = ((24MHz * N) / M) * 2$. In the fractional mode, the PLL Output is select by bit 25. Note: $8 \leq N/M \leq 25$ $(24MHz * N) / M$ must be in the range of 192MHz~600MHz. PLL_VIDEO1(1X) default is 297MHz.
30	R/W	0x0	PLL_MODE. 0: Manual Mode 1: Auto Mode (Controlled by DE).
29	/	/	/
28	R	0x0	LOCK. 0: Unlocked 1: Locked (It indicates that the PLL has been stable.)
27:26	/	/	/
25	R/W	0x1	FRAC_CLK_OUT. PLL clock output when PLL_MODE_SEL=0(PLL_PREDIV_M factor must be set to 0); No meaning when PLL_MODE_SEL =1. 0: PLL Output=270MHz 1: PLL Output =297MHz.
24	R/W	0x1	PLL_MODE_SEL. 0: Fractional Mode 1: Integer Mode. Note: When in Fractional mode, the Per Divider M should be set to 0.
23:21	/	/	/
20	R/W	0x0	PLL_SDM_EN. 0: Disable 1: Enable.
19:15	/	/	/
14:8	R/W	0x62	PLL_FACTOR_N. PLL Factor N. Factor=0, N=1 Factor=1, N=2 Factor=2, N=3 Factor=127,N=128.

7:4	/	/	/
3:0	R/W	0x7	PLL_PREDIV_M. PLL Pre-div Factor(M = Factor+1). The range is from 1 to 16.

3.3.5.9. PLL_GPU Control Register (Default Value: 0x03006207)

Offset: 0x0038			Register Name: PLL_GPU_CTRL_REG
Bit	R/W	Default/Hex	Description
31	R/W	0x0	PLL_ENABLE. 0: Disable 1: Enable. In the integer mode, The PLL_GPU = (24MHz*N)/M. In the fractional mode, the PLL Output is select by bit 25. Note: $8 \leq N/M \leq 25$ (24MHz*N)/M must be in the range of 192MHz~600MHz. PLL_GPU default is 297MHz.
30:29	/	/	/
28	R	0x0	LOCK. 0: Unlocked 1: Locked (It indicates that the PLL has been stable.)
27:26	/	/	/
25	R/W	0x1	FRAC_CLK_OUT. PLL clock output when PLL_MODE_SEL=0(PLL_PREDIV_M factor must be set to 0); no meaning when PLL_MODE_SEL =1. 0: PLL Output=270MHz 1: PLL Output=297MHz.
24	R/W	0x1	PLL_MODE_SEL. 0: Fractional Mode. 1: Integer Mode. Note: When in Fractional mode, the Per Divider M should be set to 0.
23:21	/	/	/
20	R/W	0x0	PLL_SDM_EN. 0: Disable 1: Enable.
19:15	/	/	/
14:8	R/W	0x62	PLL_FACTOR_N PLL Factor N. Factor=0, N=1 Factor=1, N=2 Factor=2, N=3 Factor=127,N=128.

7:4	/	/	/
3:0	R/W	0x7	PLL_PRE_DIV_M. PLL Pre Divider (M = Factor+1). The range is from 1 to 16.

3.3.5.10. PLL_MIPI Control Register (Default Value: 0x00000515)

Offset: 0x0040			Register Name: PLL_MIPI_CTRL_REG
Bit	R/W	Default/Hex	Description
31	R/W	0x0	PLL_ENABLE. 0: Disable 1: Enable. The PLL_MIPI= (PLL_VIDEO0(1X)*N*K)/M when VFB_SEL=0 (MIPI mode). When VFB_SEL=1, the PLL Output is depend on these bits: sint_frac,sdiv2, s6p25_7p5 , pll_feedback_div.6 Note: $K \geq 2; M/N \leq 3;$ $(PLL_VIDEO0)/M \geq 24\text{MHz};$ PLL_MIPI must be in the range of 500MHz~1.4GHz. PLL_MIPI default value is 594MHz.
30:29	/	/	/
28	R	0x0	LOCK. 0: Unlocked 1: Locked (It indicates that the PLL has been stable.)
27	R/W	0x0	SINT_FRAC. When VFB_SEL=1, PLL mode control, otherwise no meaning. 0: Integer Mode 1: Fractional Mode.
26	R/W	0x0	SDIV2. PLL clock output when VFB_SEL=1; no meaning when VFB_SEL =0 0: PLL Output 1: PLL Output X2.
25	R/W	0x0	S6P25_7P5. PLL Output is selected by this bit when VFB_SEL=1 and SINT_FRAC=1, otherwise no meaning. 0: PLL Output=PLL Input*6.25 1: PLL Output= PLL Input *7.5.
24	/	/	/
23	R/W	0	LDO1_EN. On-chip LDO1 Enable.
22	R/W	0	LDO2_EN. On-chip LDO2 Enable.
21	R/W	0	PLL_SRC.

			PLL Source Select. 0: VIDEO0 PLL 1: /.
20	R/W	0x0	PLL_SDM_EN. 0: Disable 1: Enable.
19:18	/	/	/
17	R/W	0x0	PLL_FEEDBACK_DIV. PLL feed-back divider control. PLL clock output when VFB_SEL=1; no meaning when VFB_SEL =0 0:Divided by 5 1:Divided by 7.
16	R/W	0x0	VFB_SEL. 0: MIPI Mode(N, K, M valid) 1:HDMI Mode(sint_frac,sdiv2,s6p25_7p5 , pll_feedback_div valid)
15:12	/	/	/
11:8	R/W	0x5	PLL_FACTOR_N PLL Factor N. Factor=0, N=1 Factor=1, N=2 Factor=15,N=16;
7:6	/	/	/
5:4	R/W	0x1	PLL_FACTOR_K. PLL Factor K.(K=Factor + 1) The range is from 2 to 4.
3:0	R/W	0x5	PLL_PRE_DIV_M. PLL Pre Divider (M = Factor+1). The range is from 1 to 16.

3.3.5.11. PLL_HSIC Control Register (Default Value: 0x03001300)

Offset: 0x0044			Register Name: PLL_HSIC_CTRL_REG
Bit	R/W	Default/Hex	Description
31	R/W	0x0	PLL_ENABLE. 0: Disable 1: Enable. In the integer mode, The PLL_HSIC = (24MHz*N)/M. In the fractional mode, the PLL Output is select by bit 25. Note: $8 \leq N/M \leq 25$ (24MHz*N)/M must be in the range of 192MHz~600MHz. PLL_HSIC default is 480MHz.
30:29	/	/	/

28	R	0x0	LOCK 0: Unlocked 1: Locked (It indicates that the PLL has been stable.)
27:26	/	/	/
25	R/W	0x1	FRAC_CLK_OUT. PLL clock output when PLL_MODE_SEL=0(PLL_PREDIV_M factor must be set to 0); no meaning when PLL_MODE_SEL =1. 0: PLL Output=270MHz 1: PLL Output=297MHz.
24	R/W	0x1	PLL_MODE_SEL. 0: Fractional Mode 1: Integer Mode. Note: When in Fractional mode, the Per Divider M should be set to 0.
23:21	/	/	/
20	R/W	0x0	PLL_SDM_EN. 0: Disable 1: Enable.
19:15	/	/	/
14:8	R/W	0x13	PLL_FACTOR_N PLL Factor N. Factor=0, N=1 Factor=1, N=2 Factor=2, N=3 Factor=0x7F,N=128.
7:4	/	/	/
3:0	R/W	0x0	PLL_PRE_DIV_M. PLL Per Divider (M = Factor+1). The range is from 1 to 16.

3.3.5.12. PLL_DE Control Register (Default Value: 0x03006207)

Offset: 0x0048			Register Name: PLL_DE_CTRL_REG
Bit	R/W	Default/Hex	Description
31	R/W	0x0	PLL_ENABLE. 0: Disable 1: Enable In the integer mode, The PLL Output= (24MHz*N)/M. In the fractional mode, the PLL Output is select by bit 25. Note: $8 \leq N/M \leq 25$ (24MHz*N)/M must be in the range of 192MHz~600MHz. Its default is 297MHz.
30:29	/	/	/

28	R	0x0	LOCK 0: Unlocked 1: Locked (It indicates that the PLL has been stable.)
27:26	/	/	/
25	R/W	0x1	FRAC_CLK_OUT. PLL clock output when PLL_MODE_SEL=0(PLL_PREDIV_M factor must be set to 0); no meaning when PLL_MODE_SEL =1. 0: PLL Output=270MHz 1: PLL Output =297MHz
24	R/W	0x1	PLL_MODE_SEL. 0: Fractional Mode 1: Integer Mode Note: When in Fractional mode, the Pre Divider M should be set to 0.
23:21	/	/	/
20	R/W	0x0	PLL_SDM_EN. 0: Disable 1: Enable
19:15	/	/	/
14:8	R/W	0x62	PLL_FACTOR_N PLL Factor N. Factor=0, N=1 Factor=1, N=2 Factor=2, N=3 Factor=0x7F, N=128
7:4	/	/	/
3:0	R/W	0x7	PLL_PRE_DIV_M. PLL Per Divider (M = Factor+1). The range is from 1 to 16.

3.3.5.13. PLL_DDR1 Control Register (Default Value: 0x00001800)

Offset: 0x004C			Register Name: PLL_DDR1_CTRL_REG
Bit	R/W	Default/Hex	Description
31	R/W	0x0	PLL_ENABLE. 0: Disable 1: Enable. The PLL_DDR1 = 24MHz*N/M. Note: $16 \leq N \leq 75$. 24MHz*N/M must be in the range of 192MHz~1.6GHz. Its default is 600 MHz.
30	R/W	0x0	SDRPLL_UPD. SDRPLL Configuration Update.

			Note: When PLL_DDR1 has changed, this bit should be set to 1 to validate the PLL, otherwise the change is invalid. It will be auto cleared after the PLL is valid. 0: No effect 1: To validate the PLL_DDR1.
29	/	/	/
28	R	0x0	LOCK 0: Unlocked 1: Locked (It indicates that the PLL has been stable.)
27:25	/	/	/
24	R/W	0x0	PLL_SDM_EN. 0: Disable 1: Enable.
23:15	/	/	/
14:8	R/W	0x18	PLL_FACTOR_N. N= Factor +1. The range is from 0 to 127
7:2	/	/	/
1:0	R/W	0x0	PLL_FACTOR_M. M= Factor +1. The range is from 0 to 4

3.3.5.14. CPUX/AXI Configuration Register (Default Value: 0x00010300)

Offset: 0x0050			Register Name: CPUX_AXI_CFG_REG
Bit	R/W	Default/Hex	Description
31:18	/	/	/
17:16	R/W	0x1	CPUX_CLK_SRC_SEL. CPUX Clock Source Select. CPUX Clock = Clock Source 00: LOSC 01: OSC24M 1X: PLL_CPUX If the clock source is changed, at most to wait for 8 present running clock cycles.
15:10	/	/	/
9:8	R/W	0x0	CPU_APB_CLK_DIV. 00: /1 01: /2 10: /3 11: /4 Note: System APB clock source is CPU clock source.

7:2	/	/	/
1:0	R/W	0x0	AXI_CLK_DIV_RATIO. AXI Clock Divide Ratio. AXI Clock source is CPU clock source. 00: /1 01: /2 10: /3 11: /4

3.3.5.15. AHB1/APB1 Configuration Register (Default Value: 0x00001010)

Offset: 0x0054			Register Name: AHB1_APB1_CFG_REG
Bit	R/W	Default/Hex	Description
31:14	/	/	/
13:12	R/W	0x1	AHB1_CLK_SRC_SEL. 00: LOSC 01: OSC24M 10: AXI 11: PLL_PERIPH0(1X)/ AHB1_PRE_DIV.
11:10	/	/	/
9:8	R/W	0x0	APB1_CLK_RATIO. APB1 Clock Divide Ratio. APB1 clock source is AHB1 clock. 00: /2 01: /2 10: /4 11: /8.
7:6	R/W	0x0	AHB1_PRE_DIV AHB1 Clock Pre Divide Ratio 00: /1 01: /2 10: /3 11: /4.
5:4	R/W	0x1	AHB1_CLK_DIV_RATIO. AHB1 Clock Divide Ratio. 00: /1 01: /2 10: /4 11: /8.
3:0	/	/	/

3.3.5.16. APB2 Configuration Register (Default Value: 0x01000000)

Offset: 0x0058			Register Name: APB2_CFG_REG
Bit	R/W	Default/Hex	Description
31:26	/	/	/
25:24	R/W	0x1	APB2_CLK_SRC_SEL. APB2 Clock Source Select 00: LOSC 01: OSC24M 1X: PLL_PERIPH0(2X). This clock is used for some special module apbclk(UART、TWI). Because these modules need special clock rate even if the apb1clk changed.
23:18	/	/	/
17:16	R/W	0x0	CLK_RAT_N Clock Per Divide Ratio (n) 00: /1 01: /2 10: /4 11: /8.
15:5	/	/	/
4:0	R/W	0x0	CLK_RAT_M. Clock Divide Ratio (m) The pre-divided clock is divided by (m+1). The divider is from 1 to 32.

3.3.5.17. AHB2 Configuration Register (Default Value: 0x00000000)

Offset: 0x005C			Register Name: AHB2_CFG_REG
Bit	R/W	Default/Hex	Description
31:2	/	/	/
1:0	R/W	0x0	AHB2_CLK_CFG. 00: AHB1 Clock 01: PLL_PERIPH0(1X)/2 1X: / EMAC ,USB HClO default clock source is AHB2 Clock. Its default value is 300Mhz.

3.3.5.18. Bus Clock Gating Register0 (Default Value: 0x00000000)

Offset: 0x0060			Register Name: BUS_CLK_GATING_REG0
Bit	R/W	Default/Hex	Description
31:30	/	/	/

29	R/W	0x0	USBOHCI0_GATING. Gating Clock for USB OHCI0 0: Mask 1: Pass
28	R/W	0x0	USB-OTG-OHCI_GATING. Gating Clock for USB-OTG-OHCI 0: Mask 1: Pass
27:26	/	/	/
25	R/W	0x0	USBEHCI0_GATING. Gating Clock For USB EHCI0 0: Mask 1: Pass
24	R/W	0x0	USB-OTG-EHCI_GATING. Gating Clock For USB-OTG-EHCI 0: Mask 1: Pass
23	R/W	0x0	USB-OTG-Device_GATING. Gating Clock For USB OTG Device 0: Mask 1: Pass
22	/	/	/
21	R/W	0x0	SPI1_GATING. Gating Clock For SPI1 0: Mask 1: Pass.
20	R/W	0x0	SPI0_GATING. Gating Clock For SPI0 0: Mask 1: Pass.
19	R/W	0x0	HSTMR_GATING. Gating Clock For High Speed Timer 0: Mask 1: Pass.
18	R/W	0x0	TS_GATING. Gating Clock For TS 0: Mask 1: Pass
17	R/W	0x0	EMAC_GATING. Gating Clock For EMAC 0: Mask 1: Pass
16:15	/	/	/
14	R/W	0x0	DRAM_GATING.

			Gating Clock For DRAM 0: Mask 1: Pass.
13	R/W	0x0	NAND_GATING. Gating Clock For NAND 0: Mask 1: Pass.
12:11	/	/	/
10	R/W	0x0	SMHC2_GATING. Gating Clock For SMHC2 0: Mask 1: Pass.
9	R/W	0x0	SMHC1_GATING. Gating Clock For SMHC1 0: Mask 1: Pass.
8	R/W	0x0	SMHC0_GATING. Gating Clock For SMHC0 0: Mask 1: Pass.
7	/	/	/
6	R/W	0x0	DMA_GATING. Gating Clock For DMA 0: Mask 1: Pass.
5	R/W	0x0	CE_GATING. Gating Clock For CE 0: Mask 1: Pass.
4:2	/	/	/
1	R/W	0x0	MIPIDSI_GATING. Gating Clock For MIPI DSI 0: Mask 1: Pass.
0	/	/	/

3.3.5.19. Bus Clock Gating Register1 (Default Value: 0x00000000)

Offset: 0x0064			Register Name: BUS_CLK_GATING_REG1
Bit	R/W	Default/Hex	Description
31:23	/	/	/
22	R/W	0x0	SPINLOCK_GATING.

			0: Mask 1: Pass.
21	R/W	0x0	MSGBOX_GATING. 0: Mask 1: Pass.
20	R/W	0x0	GPU_GATING. 0: Mask 1: Pass.
19:13	/	/	/
12	R/W	0x0	DE_GATING. 0: Mask 1: Pass.
11	R/W	0x0	HDMI_GATING. 0: Mask 1: Pass.
10:9	/	/	/
8	R/W	0x0	CSI_GATING. 0: Mask 1: Pass.
7:6	/	/	/
5	R/W	0x0	DEINTERLACE_GATING. Gating Clock For DEINTERLACE 0: Mask 1: Pass
4	R/W	0x0	TCON1_GATING. Gating Clock For TCON1 0: Mask 1: Pass.
3	R/W	0x0	TCON0_GATING. Gating Clock For TCON0 0: Mask 1: Pass.
2:1	/	/	/
0	R/W	0x0	VE_GATING. Gating Clock For VE 0: Mask 1: Pass.

3.3.5.20. Bus Clock Gating Register2 (Default Value: 0x00000000)

Offset: 0x0068		Register Name: BUS_CLK_GATING_REG2	
Bit	R/W	Default/Hex	Description

31:15	/	/	/
14	R/W	0x0	I2S/PCM-2_GATING. Gating Clock For I2S/PCM-2 0: Mask 1: Pass.
13	R/W	0x0	I2S/PCM-1_GATING. Gating Clock For I2S/PCM-1 0: Mask 1: Pass.
12	R/W	0x0	I2S/PCM-0_GATING. Gating Clock For I2S/PCM-0 0: Mask 1: Pass.
11:9	/	/	/
8	R/W	0x0	THS_GATING. Gating Clock For THS 0: Mask 1: Pass
6:7	/	/	/
5	R/W	0x0	PIO_GATING. Gating Clock For PIO 0: Mask 1: Pass.
4:2	/	/	/
1	R/W	0x0	SPDIF_GATING. Gating Clock For SPDIF 0: Mask 1: Pass
0	R/W	0x0	AC_DIG_GATING. Gating Clock For AC Digital 0: Mask 1: Pass

3.3.5.21. Bus Clock Gating Register3 (Default Value: 0x00000000)

Offset: 0x006C			Register Name: BUS_CLK_GATING_REG3
Bit	R/W	Default/Hex	Description
31:21	/	/	/
20	R/W	0x0	UART4_GATING. Gating Clock For UART4 0: Mask 1: Pass.

19	R/W	0x0	UART3_GATING. Gating Clock For UART3 0: Mask 1: Pass.
18	R/W	0x0	UART2_GATING. Gating Clock For UART2 0: Mask 1: Pass.
17	R/W	0x0	UART1_GATING. Gating Clock For UART1 0: Mask 1: Pass.
16	R/W	0x0	UART0_GATING. Gating Clock For UART0 0: Mask 1: Pass.
15:6	/	/	/
5	R/W	0x0	SCR_GATING. Gating Clock For SCR 0: Mask 1: Pass
4:3	/	/	/
2	R/W	0x0	TWI2_GATING. Gating Clock For TWI2 0: Mask 1: Pass.
1	R/W	0x0	TWI1_GATING. Gating Clock For TWI1 0: Mask 1: Pass.
0	R/W	0x0	TWIO_GATING. Gating Clock For TWIO 0: Mask 1: Pass.

3.3.5.22. Bus Clock Gating Register4 (Default Value: 0x00000000)

Offset: 0x0070			Register Name: BUS_CLK_GATING_REG4
Bit	R/W	Default/Hex	Description
31:8	/	/	/
7	R/W	0x0	DBGSYS_GATING. Gating Clock For DBGSYS 0: Mask

			1: Pass
6:0	/	/	/

3.3.5.23. THS Clock Register (Default Value: 0x00000000)

Offset: 0x0074			Register Name: THS_CLK_REG
Bit	R/W	Default/Hex	Description
31	R/W	0x0	SCLK_GATING. Gating Special Clock. 0: Clock is OFF 1: Clock is ON This special clock = Clock Source/CLK_DIV_RATIO.
30:26	/	/	/
25:24	R/W	0x0	THS_CLK_SRC_SEL. Clock Source Select 00: OSC24M 01: / 10: / 11: /
23:2	/	/	/
1:0	R/W	0x0	THS_CLK_DIV_RATIO. THS clock divide ratio. 00: /1 01: /2 10: /4 11: /6

3.3.5.24. NAND Clock Register (Default Value: 0x00000000)

Offset: 0x0080			Register Name: NAND_CLK_REG
Bit	R/W	Default/Hex	Description
31	R/W	0x0	SCLK_GATING. Gating Special Clock(Max Clock = 200MHz) 0: Clock is OFF 1: Clock is ON. SCLK = Clock Source/Divider N/Divider M.
30:26	/	/	/
25:24	R/W	0x0	CLK_SRC_SEL. Clock Source Select 00: OSC24M 01: PLL_PERIPH0

			10: PLL_PERIPH1 11: /
23:18	/	/	/
17:16	R/W	0x0	CLK_DIV_RATIO_N. Clock Pre Divide Ratio (n) 00: /1 01: /2 10: /4 11: /8.
15:4	/	/	/
3:0	R/W	0x0	CLK_DIV_RATIO_M Clock Divide Ratio (m) The pre-divided clock is divided by (m+1). The divider M is from 1 to 16.

3.3.5.25. SMHCO Clock Register (Default Value: 0x00000000)

Offset: 0x0088			Register Name: SMHCO_CLK_REG
Bit	R/W	Default/Hex	Description
31	R/W	0x0	SCLK_GATING. Gating Special Clock(Max Clock = 384MHz) 0: Clock is OFF 1: Clock is ON. SCLK = Clock Source/Divider N/Divider M.
30:26	/	/	/
25:24	R/W	0x0	CLK_SRC_SEL. Clock Source Select 00: OSC24M 01: PLL_PERIPH0(2X) 10: PLL_PERIPH1(2X) 11: /.
23:18	/	/	/
17:16	R/W	0x0	CLK_DIV_RATIO_N. Clock Pre Divide Ratio (n) 00: /1 01: /2 10: /4 11: /8.
15:4	/	/	/
3:0	R/W	0x0	CLK_DIV_RATIO_M. Clock Divide Ratio (m) The pre-divided clock is divided by (m+1). The divider is from 1 to 16.

3.3.5.26. SMHC1 Clock Register (Default Value: 0x00000000)

Offset: 0x008C			Register Name: SMHC1_CLK_REG
Bit	R/W	Default/Hex	Description
31	R/W	0x0	SCLK_GATING. Gating Special Clock(Max Clock = 384MHz) 0: Clock is OFF 1: Clock is ON. SCLK = Clock Source/Divider N/Divider M.
30:26	/	/	/
25:24	R/W	0x0	CLK_SRC_SEL. Clock Source Select 00: OSC24M 01: PLL_PERIPH0(2X) 10: PLL_PERIPH1(2X) 11: /.
23:18	/	/	/
17:16	R/W	0x0	CLK_DIV_RATIO_N. Clock Pre Divide Ratio (n) 00: /1 01: /2 10: /4 11: /8.
15:4	/	/	/
3:0	R/W	0x0	CLK_DIV_RATIO_M. Clock Divide Ratio (m) The pre-divided clock is divided by (m+1). The divider is from 1 to 16.

3.3.5.27. SMHC2 Clock Register (Default Value: 0x00000000)

Offset: 0x0090			Register Name: SMHC2_CLK_REG
Bit	R/W	Default/Hex	Description
31	R/W	0x0	SCLK_GATING. Gating Special Clock(Max Clock = 384MHz) 0: Clock is OFF 1: Clock is ON. SCLK = Clock Source/Divider N/Divider M.
30:26	/	/	/
25:24	R/W	0x0	CLK_SRC_SEL. Clock Source Select 00: OSC24M 01: PLL_PERIPH0(2X)

			10: PLL_PERIPH1(2X) 11: /.
23:18	/	/	/
17:16	R/W	0x0	CLK_DIV_RATIO_N. Clock Pre Divide Ratio (n) 00: /1 01: /2 10: /4 11: /8.
15:4	/	/	/
3:0	R/W	0x0	CLK_DIV_RATIO_M. Clock Divide Ratio (m) The pre-divided clock is divided by (m+1). The divider is from 1 to 16.

3.3.5.28. TS Clock Register (Default Value: 0x00000000)

Offset: 0x0098			Register Name: TS_CLK_REG
Bit	R/W	Default/Hex	Description
31	R/W	0x0	SCLK_GATING. Gating of SCLK (Max Clock = 200MHz). 0: Clock is OFF 1: Clock is ON SCLK = Clock Source/Divider N/Divider M.
30:28	/	/	/
27:24	R/W	0x0	CLK_SRC_SEL. Clock Source Select 0000: OSC24M 0001: PLL_PERIPH0(1X) Others: /
23:18	/	/	/
17:16	R/W	0x0	CLK_DIV_RATIO_N. Clock pre-divide ratio (n) The select clock source is pre-divided by 2^n. The divider is 1/2/4/8.
15:4	/	/	/
3:0	R/W	0x0	CLK_DIV_RATIO_M. Clock divide ratio (m) The pre-divided clock is divided by (m+1). The divider is from 1 to 16.

3.3.5.29. CE Clock Register (Default Value: 0x00000000)

Offset: 0x009C	Register Name: CE_CLK_REG
----------------	----------------------------------

Bit	R/W	Default/Hex	Description
31	R/W	0x0	SCLK_GATING. Gating Special Clock(Max Clock = 400MHz) 0: Clock is OFF 1: Clock is ON. SCLK = Clock Source/Divider N/Divider M.
30:26	/	/	/
25:24	R/W	0x0	CLK_SRC_SEL. Clock Source Select 00: OSC24M 01: PLL_PERIPH0 (2X) 10: PLL_PERIPH1 (2X) 11: /.
23:18	/	/	/
17:16	R/W	0x0	CLK_DIV_RATIO_N. Clock Pre Divide Ratio (n) 00: /1 01: /2 10: /4 11: /8.
15:4	/	/	/
3:0	R/W	0x0	CLK_DIV_RATIO_M. Clock divide ratio (m) The pre-divided clock is divided by (m+1). The divider is from 1 to 16.

3.3.5.30. SPI0 Clock Register (Default Value: 0x00000000)

Offset: 0x00A0			Register Name: SPI0_CLK_REG
Bit	R/W	Default/Hex	Description
31	R/W	0x0	SCLK_GATING. Gating Special Clock(Max Clock = 200MHz) 0: Clock is OFF 1: Clock is ON. SCLK = Clock Source/Divider N/Divider M.
30:26	/	/	/
25:24	R/W	0x0	CLK_SRC_SEL. Clock Source Select 00: OSC24M 01: PLL_PERIPH0(1X) 10: PLL_PERIPH1(1X) 11: /
23:18	/	/	/

17:16	R/W	0x0	CLK_DIV_RATIO_N. Clock Pre Divide Ratio (n) 00: /1 01: /2 10: /4 11: /8.
15:4	/	/	/
3:0	R/W	0x0	CLK_DIV_RATIO_M. Clock Divide Ratio (m) The pre-divided clock is divided by (m+1). The divider M is from 1 to 16.

3.3.5.31. SPI1 Clock Register (Default Value: 0x00000000)

Offset: 0x00A4			Register Name: SPI1_CLK_REG
Bit	R/W	Default/Hex	Description
31	R/W	0x0	SCLK_GATING. Gating Special Clock(Max Clock = 200MHz) 0: Clock is OFF 1: Clock is ON. SCLK= Clock Source/Divider N/Divider M.
30:26	/	/	/
25:24	R/W	0x0	CLK_SRC_SEL. Clock Source Select 00: OSC24M 01: PLL_PERIPH0(1X) 10: PLL_PERIPH1(1X) 11: /
23:18	/	/	/
17:16	R/W	0x0	CLK_DIV_RATIO_N. Clock Pre Divide Ratio (n) 00: /1 01: /2 10: /4 11: /8.
15:4	/	/	/
3:0	R/W	0x0	CLK_DIV_RATIO_M. Clock Divide Ratio (m) The pre-divided clock is divided by (m+1). The divider M is from 1 to 16.

3.3.5.32. I2S/PCM 0 Clock Register (Default Value: 0x00000000)

Offset: 0x00B0			Register Name: I2S/PCM 0_CLK_REG
Bit	R/W	Default/Hex	Description
31	R/W	0x0	SCLK_GATING. Gating Special Clock(Max Clock = 200MHz) 0: Clock is OFF 1: Clock is ON.
30:18	/	/	/
17:16	R/W	0x0	CLK_SRC_SEL. 00: PLL_AUDIO (8X) 01: PLL_AUDIO(8X)/2 10: PLL_AUDIO(8X)/4 11: PLL_AUDIO
15:0	/	/	/

3.3.5.33. I2S/PCM 1 Clock Register (Default Value: 0x00000000)

Offset: 0x00B4			Register Name: I2S/PCM 1_CLK_REG
Bit	R/W	Default/Hex	Description
31	R/W	0x0	SCLK_GATING. Gating Special Clock(Max Clock = 200MHz) 0: Clock is OFF 1: Clock is ON.
30:18	/	/	/
17:16	R/W	0x0	CLK_SRC_SEL. 00: PLL_AUDIO (8X) 01: PLL_AUDIO(8X)/2 10: PLL_AUDIO(8X)/4 11: PLL_AUDIO
15:0	/	/	/

3.3.5.34. I2S/PCM 2 Clock Register (Default Value: 0x00000000)

Offset: 0x00B8			Register Name: I2S/PCM 2_CLK_REG
Bit	R/W	Default/Hex	Description
31	R/W	0x0	SCLK_GATING. Gating Special Clock(Max Clock = 200MHz) 0: Clock is OFF 1: Clock is ON.
30:18	/	/	/

17:16	R/W	0x0	CLK_SRC_SEL. 00: PLL_AUDIO(8X) 01: PLL_AUDIO(8X)/2 10: PLL_AUDIO(8X)/4 11: PLL_AUDIO
15:0	/	/	/

3.3.5.35. OWA Clock Register (Default Value: 0x00000000)

Offset: 0x00C0			Register Name: OWA_CLK_REG
Bit	R/W	Default/Hex	Description
31	R/W	0x0	SCLK_GATING. Gating Special Clock(Max Clock = 200MHz) 0: Clock is OFF 1: Clock is ON. SCLK= PLL_AUDIO/Divider M.
30:4	/	/	/
3:0	R/W	0x0	CLK_DIV_RATIO_M. Clock Divide Ratio (m) The pre-divided clock is divided by (m+1). The divider M is from 1 to 16.

3.3.5.36. USBPHY Configuration Register (Default Value: 0x00000000)

Offset: 0x00CC			Register Name: USBPHY_CFG_REG
Bit	R/W	Default/Hex	Description
31:24	/	/	/
23:22	R/W	0x0	OHCI1_12M_SRC_SEL. OHCI1 12M Source Select 00: 12M divided from 48M 01: 12M divided from 24M 10: LOSC 11: /
21:20	R/W	0x0	OHCI0_12M_SRC_SEL. OHCI0 12M Source Select 00: 12M divided from 48M 01: 12M divided from 24M 10: LOSC 11: /
19:18	/	/	/
17:16	R/W	0x0	SCLK_GATING_OHCI. Gating Special Clock For OHCI(48M and 12M) 00: Clock is OFF

			01: OTG-OHCI Clock is ON 10: Clock is OFF 11:OTG-OHCI and OHCI0 Clock is ON
15:12	/	/	/
11	R/W	0	SCLK_GATING_12M Gating Special 12M Clock For HSIC 0: Clock is OFF 1: Clock is ON. The special 12M clock = OSC24M/2.
10	R/W	0	SCLK_GATING_HSIC Gating Special Clock For HSIC 0: Clock is OFF 1: Clock is ON. The special clock is from PLL_HSIC.
9	R/W	0x0	SCLK_GATING_USBPHY1. Gating Special Clock For USB PHY1 0: Clock is OFF 1: Clock is ON
8	R/W	0x0	SCLK_GATING_USBPHY0. Gating Special Clock For USB PHY0 0: Clock is OFF 1: Clock is ON
7:3	/	/	/
2	R/W	0x0	USBHSIC_RST. USB HSIC Reset Control 0: Assert 1: De-assert.
1	R/W	0x0	USBPHY1_RST. USB PHY1 Reset Control 0: Assert 1: De-assert
0	R/W	0x0	USBPHY0_RST. USB PHY0 Reset Control 0: Assert 1: De-assert

3.3.5.37. DRAM Configuration Register (Default Value: 0x00000000)

Offset: 0x00F4			Register Name: DRAM_CFG_REG
Bit	R/W	Default/Hex	Description
31	R/W	0x0	DRAM_CTR_RST. DRAM Controller Reset For AHB Clock Domain. 0: Assert

			1: De-assert.
30:22	/	/	/
21:20	R/W	0x0	DDR_SRC_SELECT. 00: PLL_DDR0 01: PLL_DDR1 1X: /.
19:17	/	/	/
16	R/W	0x0	SDRCLK_UPD. SDRCLK Configuration Update. 0:Invalid 1:Valid. Note: Set this bit will validate Configuration . It will be auto cleared after the Configuration is valid. The DRAMCLK Source is from PLL_DDR.
15:2	/	/	/
1:0	R/W	0x0	DRAM_DIV_M. DRAMCLK Divider of Configuration. The clock is divided by (m+1). The divider M should be from 1 to 4.

3.3.5.38. PLL_DDR Configuration Register (Default Value: 0xCCCA0000)

Offset: 0x00F8			Register Name: PLL_DDR_CFG_REG
Bit	R/W	Default/Hex	Description
31:16	R/W	0xCCCA	PLL_SSC The amplitude of SSC must be the integer times of (2^Step). Spread Frequency Amplitude =(SSC Amplitude +2^Step)*24/(2^17),unit is Mhz
15:13	/	/	/
12	R/W	0x0	PLL_DDR1_MODE. 0: Normal Mode 1: Continuously Frequency Scale.
11:7	/	/	/
6:4	R/W	0x0	PLL_DDR1_PHASE_COMPENSATE. The value of bit[6:4] is based on 24M clock, then the default PLL_DDR phase compensate is (3/24000000) s.
3:0	R/W	0x0	PLL_DDR1_STEP. 0000: 0.00439MHz/us (576/2^17) 0001: 0.00879MHz/us (576/2^16) 0010: 0.01758MHz/us (576/2^15) 0011: 0.03516MHz/us (576/2^14) 0100: 0.07031MHz/us (576/2^13) 0101: 0.14062MHz/us (576/2^12)

			0110: 0.28125MHz/us ($576/2^{11}$) 0111: 0.56250MHz/us ($576/2^{10}$) 1000: 1.12500MHz/us ($576/2^9$) 1001: 2.25000MHz/us ($576/2^8$) 1010: 4.50000MHz/us ($576/2^7$) 1011: 9.00000MHz/us ($576/2^6$) Others: 0.00439MHz/us ($576/2^{17}$).
--	--	--	---

3.3.5.39. MBUS Reset Register (Default Value: 0x80000000)

Offset: 0x00FC			Register Name: MBUS_RST_REG
Bit	R/W	Default/Hex	Description
31	R/W	0x1	MBUS_RESET. 0: Assert 1: De-assert.
30:0	/	/	/

3.3.5.40. DRAM Clock Gating Register (Default Value: 0x00000000)

Offset: 0x0100			Register Name: DRAM_CLK_GATING_REG
Bit	R/W	Default/Hex	Description
31:4	/	/	/
3	R/W	0x0	TS_DCLK_GATING. Gating DRAM Clock For TS 0: Mask 1: Pass
2	R/W	0x0	DEINTERLACE_DCLK_GATING. Gating DRAM SCLK(1X) For DEINTERLACE 0: Mask 1: Pass
1	R/W	0x0	CSI_DCLK_GATING. Gating DRAM Clock For CSI 0: Mask 1: Pass
0	R/W	0x0	VE_DCLK_GATING. Gating DRAM Clock For VE 0: Mask 1: Pass

3.3.5.41. DE Clock Gating Register (Default Value: 0x00000000)

Offset: 0x0104			Register Name: DE_CLK_REG
Bit	R/W	Default/Hex	Description
31	R/W	0x0	SCLK_GATING. Gating Special Clock 0: Clock is OFF 1: Clock is ON This special clock = Clock Source/Divider M.
30:27	/	/	/
26:24	R/W	0x0	CLK_SRC_SEL. Clock Source Select 000: PLL_PERIPH0(2X) 001: PLL_DE Others: /
23:4	/	/	/
3:0	R/W	0x0	CLK_DIV_RATIO_M. Clock Divide Ratio (m) The pre-divided clock is divided by (m+1). The divider is from 1 to 16.

3.3.5.42. TCON0 Clock Register (Default Value: 0x00000000)

Offset: 0x0118			Register Name: TCON0_CLK_REG
Bit	R/W	Default/Hex	Description
31	R/W	0x0	SCLK_GATING. Gating Special Clock 0: Clock is OFF 1: Clock is ON.
30:27	/	/	/
26:24	R/W	0x0	CLK_SRC_SEL. Clock Source Select 000: PLL_MIPI 001: / 010: PLL_VIDEO0(2X) 011~111: /.
23:0	/	/	/

3.3.5.43. TCON1 Clock Register (Default Value: 0x00000000)

Offset: 0x011C			Register Name: TCON1_CLK_REG
Bit	R/W	Default/Hex	Description

31	R/W	0x0	SCLK_GATING. Gating Special Clock 0: Clock is OFF 1: Clock is ON. SCLK = Clock Source/ Divider M.
30:26	/	/	/
25:24	R/W	0x0	SCLK_SEL. Special Clock Source Select 00: PLL_VIDEO0(1X) 01: / 10: PLL_VIDEO1(1X) 11: /.
23:4	/	/	/
3:0	R/W	0x0	CLK_DIV_RATIO_M. Clock divide ratio (m) The pre-divided clock is divided by (m+1). The divider is from 1 to 16.

3.3.5.44. DEINTERLACE Clock Register (Default Value: 0x00000000)

Offset: 0x0124			Register Name: DEINTERLACE_CLK_REG
Bit	R/W	Default/Hex	Description
31	R/W	0x0	SCLK_GATING. Gating Special Clock 0: Clock is OFF 1: Clock is ON SCLK = Clock Source/ Divider M
30:27	/	/	/
26:24	R/W	0x0	CLK_SRC_SEL. Clock Source Select 000: PLL_PERIPH0(1X) 001: PLL_PERIPH1(1X) Others: /
23:4	/	/	/
3:0	R/W	0x0	CLK_DIV_RATIO_M. Clock Divide Ratio (m) The pre-divided clock is divided by (m+1). The divider is from 1 to 16.

3.3.5.45. CSI_MISC Clock Register (Default Value: 0x00000000)

Offset: 0x0130			Register Name: CSI_MISC_CLK_REG
Bit	R/W	Default/Hex	Description

31	R/W	0x0	CSI_MISC_SCLK_GATING. Gating Special Clock 0: Clock is OFF 1: Clock is ON SCLK = OSC24M.
30:0	/	/	/

3.3.5.46. CSI Clock Register (Default Value: 0x00000000)

Offset: 0x0134			Register Name: CSI_CLK_REG
Bit	R/W	Default/Hex	Description
31	R/W	0x0	CSI_SCLK_GATING. Gating Special Clock 0: Clock is OFF 1: Clock is ON. SCLK= Special Clock Source/CSI_SCLK_DIV_M.
30:27	/	/	/
26:24	R/W	0x0	SCLK_SRC_SEL. Special Clock Source Select 000: PLL_PERIPH0(1X) 001: PLL_PERIPH1(1X) Others: /
23:20	/	/	/
19:16	R/W	0x0	CSI_SCLK_DIV_M. CSI Clock Divide Ratio (m) The pre-divided clock is divided by (m+1). The divider M is from 1 to 16.
15	R/W	0x0	CSI_MCLK_GATING. Gating Master Clock 0: Clock is OFF 1: Clock is ON This clock =Master Clock Source/ CSI_MCLK_DIV_M.
14:11	/	/	/
10:8	R/W	0x0	MCLK_SRC_SEL. Master Clock Source Select 000: OSC24M 001: PLL_VIDEO1(1X) 010: PLL_PERIPH1 Others: /
7:5	/	/	/
4:0	R/W	0x0	CSI_MCLK_DIV_M. CSI Master Clock Divide Ratio (m) The pre-divided clock is divided by (m+1). The divider is from 1 to 32.

3.3.5.47. VE Clock Register (Default Value: 0x00000000)

Offset: 0x013C			Register Name: VE_CLK_REG
Bit	R/W	Default/Hex	Description
31	R/W	0x0	VE_SCLK_GATING. Gating Special Clock 0: Clock is OFF 1: Clock is ON. SCLK = PLL_VE /Divider N.
30:19	/	/	/.
18:16	R/W	0x0	CLK_DIV_RATIO_N. Clock Pre Divide Ratio (N) The select clock source is pre-divided by n+1. The divider N is from 1 to 8.
15:0	/	/	/

3.3.5.48. AC Digital Clock Register (Default Value: 0x00000000)

Offset: 0x0140			Register Name: AC_DIG_CLK_REG
Bit	R/W	Default/Hex	Description
31	R/W	0x0	SCLK_1X_GATING. Gating Special Clock 0: Clock is OFF 1: Clock is ON. SCLK = 1X Clock Output.
30	R/W	0x0	SCLK_4X_GATING. Gating Special Clock 0: Clock is OFF 1: Clock is ON. SCLK=4X Clock Output.
29:0	/	/	/

3.3.5.49. AVS Clock Register (Default Value: 0x00000000)

Offset: 0x0144			Register Name: AVS_CLK_REG
Bit	R/W	Default/Hex	Description
31	R/W	0x0	SCLK_GATING. Gating Special Clock 0: Clock is OFF 1: Clock is ON. SCLK= OSC24M.
30:0	/	/	/

3.3.5.50. HDMI Clock Register (Default Value: 0x00000000)

Offset: 0x0150			Register Name: HDMI_CLK_REG
Bit	R/W	Default/Hex	Description
31	R/W	0x0	SCLK_GATING. Gating Special Clock 0: Clock is OFF 1: Clock is ON. SCLK= Clock Source/ Divider M.
30:26	/	/	/
25:24	R/W	0x0	SCLK_SEL. Special Clock Source Select 00: PLL_VIDEO0(1X) 01:PLL_VIDEO1(1X) Others: /
23:4	/	/	/
3:0	R/W	0x0	CLK_DIV_RATIO_M. Clock Divide Ratio (m) The pre-divided clock is divided by (m+1). The divider M is from 1 to 16.

3.3.5.51. HDMI Slow Clock Register (Default Value: 0x00000000)

Offset: 0x0154			Register Name: HDMI_SLOW_CLK_REG
Bit	R/W	Default/Hex	Description
31	R/W	0x0	HDMI_DDC_CLK_GATING. 0: Clock is OFF 1: Clock is ON. SCLK = OSC24M.
30:0	/	/	/

3.3.5.52. MBUS Clock Register (Default Value: 0x00000000)

Offset: 0x015C			Register Name: MBUS_CLK_REG
Bit	R/W	Default/Hex	Description
31	R/W	0x0	MBUS_SCLK_GATING. Gating Clock for MBUS 0: Clock is OFF 1: Clock is ON. MBUS_CLOCK = Clock Source/Divider M

30:26	/	/	/
25:24	R/W	0x0	<p>MBUS_SCLK_SRC Clock Source Select 00: OSC24M 01: PLL_PERIPH0(2X) 10: PLL_DDR0 11: PLL_DDR1.</p>
23:3	/	/	/
2:0	R/W	0x0	<p>MBUS_SCLK_RATIO_M Clock Divide Ratio (m) The pre-divided clock is divided by (m+1). The divider M is from 1 to 8. Note: If the clock has been changed ,it must wait for at least 16 cycles.</p>

3.3.5.53. MIPI_DSI Clock Register (Default Value: 0x00000000)

Offset: 0x0168			Register Name: MIPI_DSI_CLK_REG
Bit	R/W	Default/Hex	Description
31:16	/	/	/
15	R/W	0x0	<p>DSI_DPHY_GATING. Gating DSI DPHY Clock 0: Clock is OFF 1: Clock is ON. This DSI DPHY clock =Clock Source/ DPHY_CLK_DIV_M.</p>
14:10	/	/	/
9:8	R/W	0x0	<p>DSI_DPHY_SRC_SEL. DSI DPHY Clock Source Select. 00: PLL_VIDEO0(1X) 01: / 10: PLL_PERIPH0(1X) 11: /.</p>
7:4	/	/	/.
3:0	R/W	0x0	<p>DPHY_CLK_DIV_M. DSI DPHY Clock divide ratio (m) The pre-divided clock is divided by (m+1). The divider is from 1 to 16.</p>

3.3.5.54. GPU Clock Register (Default Value: 0x00000000)

Offset: 0x01A0			Register Name: GPU_CLK_REG
Bit	R/W	Default/Hex	Description
31	R/W	0x0	<p>SCLK_GATING. 0: Clock is OFF</p>

			1: Clock is ON. SCLK= PLL_GPU/Divider N.
30:3	/	/	/.
2:0	R/W	0x0	CLK_DIV_RATIO_N. Clock Pre Divide Ratio (N) The select clock source is pre-divided by(n+1). The divider N is from 1 to 8.

3.3.5.55. PLL Stable Time Register0 (Default Value: 0x000000FF)

Offset: 0x0200			Register Name: PLL_STABLE_TIME_REG0
Bit	R/W	Default/Hex	Description
31:16	/	/	/
15:0	R/W	0x00FF	PLL_LOCK_TIME PLL Lock Time (Unit: us). Note: When any PLL (except PLL_CPU) is enabled or changed, the corresponding PLL lock bit will be set after the PLL STABLE Time.

3.3.5.56. PLL Stable Time Register1 (Default Value: 0x000000FF)

Offset: 0x0204			Register Name: PLL_STABLE_TIME_REG1
Bit	R/W	Default/Hex	Description
31:16	/	/	/
15:0	R/W	0x00FF	PLL_CPU_LOCK_TIME PLL_CPU Lock Time (Unit: us). Note: When PLL_CPU is enabled or changed, the PLL_CPU lock bit will be set after the PLL_CPU STABLE Time.

3.3.5.57. PLL_PERIPH1 Bias Register (Default Value: 0x10100010)

Offset: 0x021C			Register Name: PLL_PERIPH1_BIAS_REG
Bit	R/W	Default/Hex	Description
31:29	/	/	/
28:24	R/W	0x10	PLL_VCO_BIAS_CTRL. PLL VCO Bias Control[4:0].
23:21	/	/	/
20:16	R/W	0x10	PLL_CUR_BIAS_CTRL. PLL Current Bias Control[4:0].
15:5	/	/	/
4	R/W	0x1	PLL_BANDW_CTRL.

			PLL Band Width Control. 0: Narrow 1: Wide.
3:2	/	/	/
1:0	R/W	0x0	PLL_DAMP_FACTOR_CTRL. PLL Damping Factor Control[1:0].

3.3.5.58. PLL_CPUX Bias Register (Default Value: 0x08100200)

Offset: 0x0220			Register Name: PLL_CPUX_BIAS_REG
Bit	R/W	Default/Hex	Description
31	R/W	0x0	VCO_RST. VCO reset in.
30:29	/	/	/
28	R/W	0x0	EXG_MODE. Exchange Mode. Note: CPU PLL source will select PLL_PERIPH0 instead of PLL_CPU
27:24	R/W	0x8	PLL_VCO_BIAS_CTRL. PLL VCO Bias Control[3:0].
23:21	/	/	/
20:16	R/W	0x10	PLL_CUR_BIAS_CTRL. PLL Current Bias Control[4:0].
15:11	/	/	/
10:8	R/W	0x2	PLL_LOCK_CTRL. PLL Lock Time Control[2:0].
7:4	/	/	/
3:0	R/W	0x0	PLL_DAMP_FACT_CTRL. PLL Damping Factor Control[3:0].

3.3.5.59. PLL_AUDIO Bias Register (Default Value: 0x10100000)

Offset: 0x0224			Register Name: PLL_AUDIO_BIAS_REG
Bit	R/W	Default/Hex	Description
31:29	/	/	/
28:24	R/W	0x10	PLL_VCO_BIAS. PLL VCO Bias Current[4:0].
23:21	/	/	/
20:16	R/W	0x10	PLL_CUR_BIAS_CTRL. PLL Current Bias Control[4:0].
15:0	/	/	/

3.3.5.60. PLL_VIDEO0 Bias Register (Default Value: 0x10100000)

Offset: 0x0228			Register Name: PLL_VIDEO0_BIAS_REG
Bit	R/W	Default/Hex	Description
31:29	/	/	/
28:24	R/W	0x10	PLL_VCO_BIAS_CTRL. PLL VCO Bias Control[4:0].
23:21	/	/	/
20:16	R/W	0x10	PLL_CUR_BIAS_CTRL. PLL Current Bias Control[4:0].
15:3	/	/	/
2:0	R/W	0x0	PLL_DAMP_FACTOR_CTRL. PLL Damping Factor Control[2:0].

3.3.5.61. PLL_VE Bias Register (Default Value: 0x10100000)

Offset: 0x022C			Register Name: PLL_VE_BIAS_REG
Bit	R/W	Default/Hex	Description
31:29	/	/	/
28:24	R/W	0x10	PLL_VCO_BIAS_CTRL. PLL VCO Bias Control[4:0].
23:21	/	/	/
20:16	R/W	0x10	PLL_CUR_BIAS_CTRL. PLL Current Bias Control[4:0].
15:3	/	/	/
2:0	R/W	0x0	PLL_DAMP_FACTOR_CTRL. PLL Damping Factor Control[2:0].

3.3.5.62. PLL_DDR0 Bias Register (Default Value: 0x81104000)

Offset: 0x0230			Register Name: PLL_DDR0_BIAS_REG
Bit	R/W	Default/Hex	Description
31:28	R/W	0x8	PLL_VCO_BIAS. PLL VCO Bias Control[3:0].
27:26	/	/	/.
25	R/W	0x0	PLL_VCO_GAIN_CTRL_EN. PLL VCO Gain Control Enable. 0: Disable 1: Enable.
24	R/W	0x1	PLL_BANDW_CTRL.

			PLL Band Width Control. 0: Narrow 1: Wide.
23:21	/	/	/
20:16	R/W	0x10	PLL_CUR_BIAS_CTRL. PLL Current Bias Control[4:0].
15	/	/	/
14:12	R/W	0x4	PLL_VCO_GAIN_CTRL. PLL VCO Gain Control Bit[2:0].
11:4	/	/	/
3:0	R/W	0x0	PLL_DAMP_FACTOR_CTRL. PLL Damping Factor Control[3:0].

3.3.5.63. PLL_PERIPH0 Bias Register (Default Value: 0x10100010)

Offset: 0x0234			Register Name: PLL_PERIPH0_BIAS_REG
Bit	R/W	Default/Hex	Description
31:29	/	/	/
28:24	R/W	0x10	PLL_VCO_BIAS. PLL VCO Bias[4:0].
23:21	/	/	/
20:16	R/W	0x10	PLL_BIAS_CUR_CTRL. PLL Bias Current Control.
15:5	/	/	/
4	R/W	0x1	PLL_BANDW_CTRL. PLL Band Width Control. 0: Narrow 1: Wide
3:2	/	/	/
1:0	R/W	0x0	PLL_DAMP_FACTOR_CTRL. PLL Damping Factor Control[1:0].

3.3.5.64. PLL_VIDEO1 Bias Register (Default Value: 0x10100000)

Offset: 0x0238			Register Name: PLL_VIDEO1_BIAS_REG
Bit	R/W	Default/Hex	Description
31:29	/	/	/
28:24	R/W	0x10	PLL_VCO_BIAS_CTRL. PLL VCO Bias Control[4:0].
23:21	/	/	/
20:16	R/W	0x10	PLL_CUR_BIAS_CTRL.

			PLL Current Bias Control[4:0].
15:3	/	/	/
2:0	R/W	0x0	PLL_DAMP_FACTOR_CTRL. PLL Damping Factor Control[2:0].

3.3.5.65. PLL_GPU Bias Register (Default Value: 0x10100000)

Offset: 0x023C			Register Name: PLL_GPU_BIAS_REG
Bit	R/W	Default/Hex	Description
31:29	/	/	/
28:24	R/W	0x10	PLL_VCO_BIAS_CTRL. PLL VCO Bias Control[4:0].
23:21	/	/	/
20:16	R/W	0x10	PLL_CUR_BIAS_CTRL. PLL Current Bias Control[4:0].
15:3	/	/	/
2:0	R/W	0x0	PLL_DAMP_FACTOR_CTRL. PLL Damping Factor Control[2:0].

3.3.5.66. PLL_MIPI Bias Register (Default Value: 0XF8100400)

Offset: 0x0240			Register Name: PLL_MIPI_BIAS_REG																		
Bit	R/W	Default/Hex	Description																		
31	R/W	0x1	VCO_RST. VCO Reset In.																		
30:28	R/W	0x7	PLLVDD_LDO_OUT_CTRL. PLLVDD LDO Output Control. <table border="0" style="width: 100%; border-collapse: collapse;"> <tr> <td style="width: 50%;">PLL_IN_POWER_SEL=1</td> <td style="width: 50%;">PLL_IN_POWER_SEL=0</td> </tr> <tr> <td>000:1.00v</td> <td>000:1.20v</td> </tr> <tr> <td>001:1.02v</td> <td>001:1.225v</td> </tr> <tr> <td>010:1.04v</td> <td>010:1.25v</td> </tr> <tr> <td>011:1.06v</td> <td>011:1.275v</td> </tr> <tr> <td>100: 1.08v</td> <td>100:1.30v</td> </tr> <tr> <td>101:1.10v</td> <td>101:1.325v</td> </tr> <tr> <td>110:1.12v</td> <td>110:1.35v</td> </tr> <tr> <td>111:1.14v.</td> <td>111:1.375v</td> </tr> </table> The PLL_IN_PWR_SEL is in the PLL_MIPI Tuning Register.	PLL_IN_POWER_SEL=1	PLL_IN_POWER_SEL=0	000:1.00v	000:1.20v	001:1.02v	001:1.225v	010:1.04v	010:1.25v	011:1.06v	011:1.275v	100: 1.08v	100:1.30v	101:1.10v	101:1.325v	110:1.12v	110:1.35v	111:1.14v.	111:1.375v
PLL_IN_POWER_SEL=1	PLL_IN_POWER_SEL=0																				
000:1.00v	000:1.20v																				
001:1.02v	001:1.225v																				
010:1.04v	010:1.25v																				
011:1.06v	011:1.275v																				
100: 1.08v	100:1.30v																				
101:1.10v	101:1.325v																				
110:1.12v	110:1.35v																				
111:1.14v.	111:1.375v																				
27:24	R/W	0x8	PLL_VCO_BIAS_CTRL. PLL VCO Bias Control [3:0].																		
23:21	/	/	/																		
20:16	R/W	0x10	PLL_CUR_BIAS_CTRL.																		

			PLL Current Bias Control[4:0].
15:11	/	/	/
10:8	R/W	0x4	PLL_LOCK_CTRL. PLL Lock Time Control[2:0].
7:1	/	/	/
0	R/W	0x0	PLL_DAMP_FACT_CTRL. PLL Damping Factor Control.

3.3.5.67. PLL_HSIC Bias Register (Default Value: 0x10100000)

Offset: 0x0244			Register Name: PLL_HSIC_BIAS_REG
Bit	R/W	Default/Hex	Description
31:29	/	/	/
28:24	R/W	0x10	PLL_VCO_BIAS. PLL VCO Bias[4:0].
23:21	/	/	/
20:16	R/W	0x10	PLL_CUR_BIAS_CTRL. PLL Current Bias Control[4:0].
15:3	/	/	/.
2:0	R/W	0x0	PLL_DAMP_FACTOR_CTRL. PLL Damping Factor Control[2:0].

3.3.5.68. PLL_DE Bias Register (Default Value: 0x10100000)

Offset: 0x0248			Register Name: PLL_DE_BIAS_REG
Bit	R/W	Default/Hex	Description
31:29	/	/	/
28:24	R/W	0x10	PLL_VCO_BIAS_CTRL. PLL VCO Bias Control[4:0].
23:21	/	/	/
20:16	R/W	0x10	PLL_CUR_BIAS_CTRL. PLL Current Bias Control[4:0].
15:3	/	/	/
2:0	R/W	0x0	PLL_DAMP_FACTOR_CTRL. PLL Damping Factor Control[2:0].

3.3.5.69. PLL_DDR1 Bias Register (Default Value: 0x10010000)

Offset: 0x024C	Register Name: PLL_DDR1_BIAS_REG
----------------	---

Bit	R/W	Default/Hex	Description
31:29	/	/	/
28:24	R/W	0x10	PLL_VCO_BIAS_CTRL. PLL VCO Bias Control[4:0].
23:21	/	/	/
20:16	R/W	0x01	PLL_CUR_BIAS_CTRL. PLL Current Bias Control[4:0].
15:0	/	/	/

3.3.5.70. PLL_CPUX Tuning Register (Default Value: 0x0A101000)

Offset: 0x0250			Register Name: PLL_CPUX_TUN_REG
Bit	R/W	Default/Hex	Description
31:28	/	/	/
27	R/W	0x1	PLL_BAND_WID_CTRL. PLL Band Width Control. 0: Narrow 1: Wide
26	R/W	0x0	VCO_GAIN_CTRL_EN. VCO Gain Control Enable. 0: Disable 1: Enable
25:23	R/W	0x4	VCO_GAIN_CTRL. VCO Gain Control Bits[2:0].
22:16	R/W	0x10	PLL_INIT_FREQ_CTRL. PLL Initial Frequency Control[6:0].
15	R/W	0x0	C_OD. C-Reg-Od For Verify.
14:8	R/W	0x10	C_B_IN. C-B-In[6:0] For Verify.
7	R/W	0x0	C_OD1. C-Reg-Od1 For Verify.
6:0	R	0x0	C_B_OUT. C-B-Out[6:0] For Verify.

3.3.5.71. PLL_DDR0 Tuning Register (Default Value: 0x14880000)

Offset: 0x0260			Register Name: PLL_DDR0_TUN_REG
Bit	R/W	Default/Hex	Description
31:29	/	/	/
28	R/W	0x1	VREG1_OUT_EN.

			Vreg1 Out Enable. 0: Disable 1: Enable
27	/	/	/
26:24	R/W	0x4	PLL_LTIME_CTRL. PLL Lock Time Control[2:0].
23	R/W	0x1	VCO_RST. VCO Reset In.
22:16	R/W	0x08	PLL_INIT_FREQ_CTRL. PLL Initial Frequency Control[6:0].
15	R/W	0x0	OD1. Reg-Od1 For Verify.
14:8	R/W	0x0	B_IN. B-In[6:0] For Verify.
7	R/W	0x0	OD. Reg-Od For Verify.
6:0	R	0x0	B_OUT. B-Out[6:0] For Verify.

3.3.5.72. PLL_MIPI Tuning Register (Default Value: 0x8A002000)

Offset: 0x0270			Register Name: PLL_MIPI_TUN_REG
Bit	R/W	Default/Hex	Description
31	R/W	0x1	PLL_INPUT_POWER_SEL. 0:2.5V 1:3.0V.
30	/	/	/
29:28	R/W	0x0	VREG_OUT_EN. For Verify
27	R/W	0x1	PLL_BAND_WID_CTRL. PLL Band Width Control. 0: Narrow 1: Wide.
26	R/W	0x0	VCO_GAIN_CTRL_EN. VCO Gain Control Enable. 0: Disable 1: Enable.
25:23	R/W	0x4	VCO_GAIN_CTRL. VCO Gain Control Bits[2:0].
22	/	/	/
21:16	R/W	0x0	CNT_INT. For Verify[5:0].

15	R/W	0x0	C_OD. C-Reg-Od For Verify
14	/	/	/
13:8	R/W	0x20	C_B_IN. C-B-In[5:0] For Verify
7	R/W	0x0	C_OD1. C-Reg-Od1 For Verify
6	/	/	/
5:0	R		C_B_OUT. C-B-Out[5:0] For Verify

3.3.5.73. PLL_PERIPH1 Pattern Control Register (Default Value: 0x00000000)

Offset: 0x027C			Register Name: PLL_PERIPH1_PAT_CTRL_REG
Bit	R/W	Default/Hex	Description
31	R/W	0x0	SIG_DELT_PAT_EN. Sigma-Delta Pattern Enable.
30:29	R/W	0x0	SPR_FREQ_MODE. Spread Frequency Mode. 00: DC=0 01: DC=1 1X: Triangular.
28:20	R/W	0x0	WAVE_STEP. Wave Step.
19	/	/	/
18:17	R/W	0x0	FREQ. Frequency. 00: 31.5KHz 01: 32KHz 10: 32.5KHz 11: 33KHz.
16:0	R/W	0x0	WAVE_BOT. Wave Bottom.

3.3.5.74. PLL_CPUX Pattern Control Register (Default Value: 0x00000000)

Offset: 0x0280			Register Name: PLL_CPUX_PAT_CTRL_REG
Bit	R/W	Default/Hex	Description
31	R/W	0x0	SIG_DELT_PAT_EN. Sigma-delta Pattern Enable.
30:29	R/W	0x0	SPR_FREQ_MODE.

			Spread Frequency Mode. 00: DC=0 01: DC=1 1X: Triangular
28:20	R/W	0x0	WAVE_STEP. Wave Step.
19	/	/	/
18:17	R/W	0x0	FREQ. Frequency. 00: 31.5KHz 01: 32KHz 10: 32.5KHz 11: 33KHz
16:0	R/W	0x0	WAVE_BOT. Wave Bottom.

3.3.5.75. PLL_AUDIO Pattern Control Register(Default Value: 0x00000000)

Offset: 0x0284			Register Name: PLL_AUDIO_PAT_CTRL_REG
Bit	R/W	Default/Hex	Description
31	R/W	0x0	SIG_DELT_PAT_EN. Sigma-delta Pattern Enable.
30:29	R/W	0x0	SPR_FREQ_MODE. Spread Frequency Mode. 00: DC=0 01: DC=1 1X: Triangular
28:20	R/W	0x0	WAVE_STEP. Wave Step.
19	/	/	/
18:17	R/W	0x0	FREQ. Frequency. 00: 31.5KHz 01: 32KHz 10: 32.5KHz 11: 33KHz
16:0	R/W	0x0	WAVE_BOT. Wave Bottom.

3.3.5.76. PLL_VIDEO0 Pattern Control Register (Default Value: 0x00000000)

Offset: 0x0288			Register Name: PLL_VIDEO0_PAT_CTRL_REG
Bit	R/W	Default/Hex	Description
31	R/W	0x0	SIG_DELT_PAT_EN. Sigma-delta Pattern Enable.
30:29	R/W	0x0	SPR_FREQ_MODE. Spread Frequency Mode. 00: DC=0 01: DC=1 1X: Triangular
28:20	R/W	0x0	WAVE_STEP. Wave Step.
19	/	/	/
18:17	R/W	0x0	FREQ. Frequency. 00: 31.5KHz 01: 32KHz 10: 32.5KHz 11: 33KHz
16:0	R/W	0x0	WAVE_BOT. Wave Bottom.

3.3.5.77. PLL_VE Pattern Control Register (Default Value: 0x00000000)

Offset: 0x028C			Register Name: PLL_VE_PAT_CTRL_REG
Bit	R/W	Default/Hex	Description
31	R/W	0x0	SIG_DELT_PAT_EN. Sigma-delta Pattern Enable.
30:29	R/W	0x0	SPR_FREQ_MODE. Spread Frequency Mode. 00: DC=0 01: DC=1 1X: Triangular
28:20	R/W	0x0	WAVE_STEP. Wave Step.
19	/	/	/
18:17	R/W	0x0	FREQ. Frequency. 00: 31.5KHz 01: 32KHz 10: 32.5KHz

			11: 33KHz
16:0	R/W	0x0	WAVE_BOT. Wave Bottom.

3.3.5.78. PLL_DDR0 Pattern Control Register (Default Value: 0x00000000)

Offset: 0x0290			Register Name: PLL_DDR0_PAT_CTRL_REG
Bit	R/W	Default/Hex	Description
31	R/W	0x0	SIG_DELT_PAT_EN. Sigma-delta Pattern Enable.
30:29	R/W	0x0	SPR_FREQ_MODE. Spread Frequency Mode. 00: DC=0 01: DC=1 1X: Triangular
28:20	R/W	0x0	WAVE_STEP. Wave step.
19	/	/	/
18:17	R/W	0x0	FREQ. Frequency. 00: 31.5KHz 01: 32KHz 10: 32.5KHz 11: 33KHz
16:0	R/W	0x0	WAVE_BOT. Wave Bottom.

3.3.5.79. PLL_VIDEO1 Pattern Control Register (Default Value: 0x00000000)

Offset: 0x0298			Register Name: PLL_VIDEO1_PAT_CTRL_REG
Bit	R/W	Default/Hex	Description
31	R/W	0x0	SIG_DELT_PAT_EN. Sigma-Delta Pattern Enable.
30:29	R/W	0x0	SPR_FREQ_MODE. Spread Frequency Mode. 00: DC=0 01: DC=1 1X: Triangular.
28:20	R/W	0x0	WAVE_STEP. Wave Step.
19	/	/	/

18:17	R/W	0x0	FREQ. Frequency. 00: 31.5KHz 01: 32KHz 10: 32.5KHz 11: 33KHz.
16:0	R/W	0x0	WAVE_BOT. Wave Bottom.

3.3.5.80. PLL_GPU Pattern Control Register (Default Value: 0x00000000)

Offset: 0x029C			Register Name: PLL_GPU_PAT_CTRL_REG
Bit	R/W	Default/Hex	Description
31	R/W	0x0	SIG_DELT_PAT_EN. Sigma-Delta Pattern Enable.
30:29	R/W	0x0	SPR_FREQ_MODE. Spread Frequency Mode. 00: DC=0 01: DC=1 1X: Triangular
28:20	R/W	0x0	WAVE_STEP. Wave Step.
19	/	/	/
18:17	R/W	0x0	FREQ. Frequency. 00: 31.5KHz 01: 32KHz 10: 32.5KHz 11: 33KHz
16:0	R/W	0x0	WAVE_BOT. Wave Bottom.

3.3.5.81. PLL_MIPI Pattern Control Register (Default Value: 0x00000000)

Offset: 0x02A0			Register Name: PLL_MIPI_PAT_CTRL_REG
Bit	R/W	Default/Hex	Description
31	R/W	0x0	SIG_DELT_PAT_EN. Sigma-Delta Pattern Enable.
31	R/W	0x0	SIG_DELT_PAT_EN. Sigma-Delta Pattern Enable.
30:29	R/W	0x0	SPR_FREQ_MODE.

			Spread Frequency Mode. 00: DC=0 01: DC=1 1X: Triangular.
28:20	R/W	0x0	WAVE_STEP. Wave Step.
19	/	/	/
18:17	R/W	0x0	FREQ. Frequency. 00: 31.5KHz 01: 32KHz 10: 32.5KHz 11: 33KHz.
16:0	R/W	0x0	WAVE_BOT. Wave Bottom.

3.3.5.82. PLL_HSIC Pattern Control Register (Default Value: 0x00000000)

Offset: 0x02A4			Register Name: PLL_HSIC_PAT_CTRL_REG
Bit	R/W	Default/Hex	Description
31	R/W	0x0	SIG_DELT_PAT_EN. Sigma-Delta Pattern Enable.
30:29	R/W	0x0	SPR_FREQ_MODE. Spread Frequency Mode. 00: DC=0 01: DC=1 1X: Triangular
28:20	R/W	0x0	WAVE_STEP. Wave Step.
19	/	/	/
18:17	R/W	0x0	FREQ. Frequency. 00: 31.5KHz 01: 32KHz 10: 32.5KHz 11: 33KHz
16:0	R/W	0x0	WAVE_BOT. Wave Bottom.

3.3.5.83. PLL_DE Pattern Control Register (Default Value: 0x00000000)

Offset: 0x02A8			Register Name: PLL_DE_PAT_CTRL_REG
Bit	R/W	Default/Hex	Description
31	R/W	0x0	SIG_DELT_PAT_EN. Sigma-Delta Pattern Enable.
30:29	R/W	0x0	SPR_FREQ_MODE. Spread Frequency Mode. 00: DC=0 01: DC=1 1X: Triangular
28:20	R/W	0x0	WAVE_STEP. Wave Step.
19	/	/	/
18:17	R/W	0x0	FREQ. Frequency. 00: 31.5KHz 01: 32KHz 10: 32.5KHz 11: 33KHz
16:0	R/W	0x0	WAVE_BOT. Wave Bottom.

3.3.5.84. PLL_DDR1 Pattern Control Register0 (Default Value: 0x00000000)

Offset: 0x02AC			Register Name: PLL_DDR1_PAT_CTRL_REG0
Bit	R/W	Default/Hex	Description
31	R/W	0x0	SIG_DELT_PAT_EN. Sigma-Delta Pattern Enable.
30:29	R/W	0x0	SPR_FREQ_MODE. Spread Frequency Mode. 00: DC=0 01: DC=1 10: / 11: Triangular.
28:20	R/W	0x0	WAVE_STEP. Wave Step.
19	/	/	/
18:17	R/W	0x0	FREQ. Frequency. 00: 31.5KHz 01: 32KHz

			10: 32.5KHz 11: 33KHz.
16:0	R/W	0x0	WAVE_BOT. Wave Bottom.

3.3.5.85. PLL_DDR1 Pattern Control Register1 (Default Value: 0x00000000)

Offset: 0x02B0			Register Name: PLL_DDR1_PAT_CTRL_REG1
Bit	R/W	Default/Hex	Description
30:25	/	/	/
24	R/W	0x0	DITHER_EN.
23:21	/	/	/
20	R/W	0x0	FRAC_EN.
19:17	/	/	/
16:0	R/W	0x0	FRAC_IN.

3.3.5.86. Bus Software Reset Register 0 (Default Value: 0x00000000)

Offset: 0x02C0			Register Name: BUS_SOFT_RST_REG0
Bit	R/W	Default/Hex	Description
31:30	/	/	/
29	R/W	0x0	USB-OHCI0_RST. USB-OHCI0 Reset Control 0: Assert 1: De-assert
28	R/W	0x0	USB-OTG-OHCI_RST. USB-OTG-OHCI Reset Control 0: Assert 1: De-assert
27:26	/	/	/
25	R/W	0x0	USB-EHCI0_RST. USB-EHCI0 Reset Control 0: Assert 1: De-assert.
24	R/W	0x0	USB-OTG-EHCI_RST. USB-OTG-EHCI Reset Control 0: Assert 1: De-assert
23	R/W	0x0	USB-OTG-Device_RST. USB-OTG-Device Reset Control 0: Assert

			1: De-assert
22	/	/	/
21	R/W	0x0	SPI1_RST. SPI1 Reset. 0: Assert 1: De-assert
20	R/W	0x0	SPIO_RST. SPIO Reset. 0: Assert 1: De-assert
19	R/W	0x0	HSTMR_RST. HSTMR Reset. 0: Assert 1: De-assert
18	R/W	0x0	TS_RST. TS Reset. 0: Assert 1: De-assert
17	R/W	0x0	EMAC_RST. EMAC Reset. 0: Assert 1: De-assert
16:15	/	/	/
14	R/W	0x0	SDRAM_RST. SDRAM AHB Reset. 0: Assert 1: De-assert
13	R/W	0x0	NAND_RST. NAND Reset. 0: Assert 1: De-assert
12:11	/	/	/
10	R/W	0x0	SMHC2_RST. SMHC2 Reset. 0: Assert 1: De-assert.
9	R/W	0x0	SMHC1_RST. SMHC1 Reset. 0: Assert 1: De-assert.
8	R/W	0x0	SMHC0_RST. SMHC0 Reset. 0: Assert 1: De-assert.

7	/	/	/
6	R/W	0x0	DMA_RST. DMA Reset. 0: Assert 1: De-assert
5	R/W	0x0	CE_RST. CE Reset. 0: Assert 1: De-assert
4:2	/	/	/
1	R/W	0x0	MIPI_DSI_RST. MIPI DSI Reset. 0: Assert 1: De-assert.
0	/	/	/

3.3.5.87. Bus Software Reset Register 1 (Default Value: 0x00000000)

Offset: 0x02C4			Register Name: BUS_SOFT_RST_REG1
Bit	R/W	Default/Hex	Description
31	R/W	0x0	DBGSYS_RST. DBGSYS Reset. 0: Assert 1: De-assert
30:23	/	/	/
22	R/W	0x0	SPINLOCK_RST. SPINLOCK Reset. 0: Assert 1: De-assert.
21	R/W	0x0	MSGBOX_RST. MSGBOX Reset. 0: Assert 1: De-assert.
20	R/W	0x0	GPU_RST. GPU Reset. 0: Assert 1: De-assert.
19:13	/	/	/
12	R/W	0x0	DE_RST. DE Reset. 0: Assert 1: De-assert.

11	R/W	0x0	HDMI1_RST. HDMI1 Reset. 0: Assert 1: De-assert.
10	R/W	0x0	HDMI0_RST. HDMI0 Reset. 0: Assert 1: De-assert.
9	/	/	/
8	R/W	0x0	CSI_RST. CSI Reset. 0: Assert 1: De-assert.
7:6	/	/	/
5	R/W	0x0	DEINTERLACE_RST. DEINTERLACE Reset. 0: Assert 1:De-assert
4	R/W	0x0	TCON1_RST. TCON1 Reset. 0: Assert 1: De-assert.
3	R/W	0x0	TCON0_RST. TCON0 Reset. 0: Assert 1: De-assert.
2:1	/	/	/
0	R/W	0x0	VE_RST. VE Reset. 0: Assert 1: De-assert.

3.3.5.88. Bus Software Reset Register 2 (Default Value: 0x00000000)

Offset: 0x02C8			Register Name: BUS_SOFT_RST_REG2
Bit	R/W	Default/Hex	Description
31:1	/	/	/
0	R/W	0x0	LVDS_RST. LVDS Reset. 0: Assert 1: De-assert.

3.3.5.89. Bus Software Reset Register 3 (Default Value: 0x00000000)

Offset: 0x02D0			Register Name: BUS_SOFT_RST_REG3
Bit	R/W	Default/Hex	Description
31:15	/	/	/
14	R/W	0x0	I2S/PCM 2_RST. I2S/PCM 2 Reset. 0: Assert 1: De-assert.
13	R/W	0x0	I2S/PCM 1_RST. I2S/PCM 1 Reset. 0: Assert 1: De-assert.
12	R/W	0x0	I2S/PCM 0_RST. I2S/PCM 0 Reset. 0: Assert 1: De-assert.
11:9	/	/	/
8	R/W	0x0	THS_RST. THS Reset. 0: Assert 1: De-assert
7:2	/	/	/
1	R/W	0x0	OWA_RST. OWA Reset. 0: Assert 1: De-assert
0	R/W	0x0	AC_RST. AC Reset. 0: Assert 1: De-assert

3.3.5.90. Bus Software Reset Register 4 (Default Value: 0x00000000)

Offset: 0x02D8			Register Name: BUS_SOFT_RST_REG4
Bit	R/W	Default/Hex	Description
31:21	/	/	/
20	R/W	0x0	UART4_RST. UART4 Reset. 0: Assert 1: De-assert.
19	R/W	0x0	UART3_RST.

			UART3 Reset. 0: Assert 1: De-assert.
18	R/W	0x0	UART2_RST. UART2 Reset. 0: Assert 1: De-assert.
17	R/W	0x0	UART1_RST. UART1 Reset. 0: Assert 1: De-assert.
16	R/W	0x0	UART0_RST. UART0 Reset. 0: Assert 1: De-assert.
15:6	/	/	/
5	R/W	0x0	SCR_RST. SCR Reset. 0: Assert 1: De-assert
4:3	/	/	/
2	R/W	0x0	TWI2_RST. TWI2 Reset. 0: Assert 1: De-assert.
1	R/W	0x0	TWI1_RST. TWI1 Reset. 0: Assert 1: De-assert.
0	R/W	0x0	TWIO_RST. TWIO Reset. 0: Assert 1: De-assert.

3.3.5.91. CCU Security Switch Register (Default Value: 0x00000000)

Offset: 0x02F0			Register Name: CCU_SEC_SWITCH_REG
Bit	R/W	Default/Hex	Description
31:3	/	/	/
2	R/W	0x0	MBUS_SEC MBUS clock register security 0:Secure 1:Non-secure

			Including MBUS Reset Register and MBUS Clock Register
1	R/W	0x0	BUS_SEC Bus relevant registers' security 0:Secure 1:Non-secure Including AXI/AHB/APB relevant registers,such as CPUX/AXI Configuration Register,AHB1/APB1 Configuration Register,APB2 Configuration Register, AHB2 Configuration Register.
0	R/W	0x0	PLL_SEC PLL relevant registers' security. 0:Secure 1:Non-secure Including PLL_CPUX Control Register, PLL_AUDIO Control Register, PLL_VIDEO0 Control Register, PLL_VIDEO1 Control Register, PLL_VE Control Register, PLL_DDR0 Control Register,PLL_DDR1 Control Register, PLL_PERIPH0 Control Register, PLL_PERIPH1 Control Register,PLL_GPU Control Register, PLL_MIPI Control Register, PLL_HSIC Control Register, PLL_DE Control Register and offset from 0x200 to 0x2B0 relevant registers.

3.3.5.92. PS Control Register (Default Value: 0x00000000)

Offset: 0x0300			Register Name: PS_CTRL_REG
Bit	R/W	Default/Hex	Description
31:10	/	/	/
9:8	R/W	0x0	DEC_SEL Device Select
7	R/W	0x0	DET_FIN. Detect Finish. 0: Unfinished 1: Finished Set 1 to this bit will clear it.
6	R/W	0x0	DLY_SEL. Delay Select 0: 1 Cycle 1: 2 Cycles
5:4	R/W	0x0	OSC_SEL OSC Select. 00: IDLE 01: SVT 10: LVT 11: ULVT
3:1	R/W	0x0	TIME_DET.

			Time detect. 000: 0.5/4 us 001: 0.5/2 us 002: 0.5/1 us 003: 0.5*2us 111:0.5*2^5us
0	R/W	0x0	MOD_EN. Module enable. 0: Disable 1: Enable

3.3.5.93. PS Counter Register (Default Value: 0x00000000)

Offset: 0x0304			Register Name: PS_CNT_REG
Bit	R/W	Default/Hex	Description
31:16	/	/	/
15:0	R/W	0x0	PS_CNT. PS Counter.

3.3.5.94. PLL Lock Control Register (Default Value: 0x00000000)

Offset: 0x0320			Register Name: PLL_LOCK_CTRL_REG
Bit	R/W	Default/Hex	Description
31:29	/	/	/
28	R/W	0x0	MODE_SEL Mode Select 0: Old Mode 1: New Mode
27:25	/	/	/
24	R/W	0x0	DBG_EN Debug Enable 0: Disable 1: Enable
23:20	R/W	0x0	DBG_SEL Debug Select 0000: PLL_CPUX 0001: PLL_AUDIO 0010: PLL_VIDEO0 0011: PLL_VE 0100: PLL_DDR0

			0101: PLL_PERIPH0 0110: PLL_VIDEO1 0111: PLL_GPU 1000: PLL_MIPI 1001: PLL_HSIC 1010: PLL_DE 1011: PLL_DDR1 1100: PLL_PERIPH1 Others: /
19	/	/	/
18:17	R/W	0x0	UNLOCK_LEVEL Unlock Level 00: 21-29 Clock Cycles 01: 22-28 Clock Cycles 1X: 20-30 Clock Cycles
16	R/W	0x0	LOCK_LEVEL Lock Level 0: 24-26 Clock Cycles 1: 23-27 Clock Cycles
15:13	/	/	/
12:0	R/W	0x0	LOCK_EN Lock Enable Bit12: PLL_PERIPH1 Bit11: PLL_DDR1 Bit10: PLL_DE Bit9: PLL_HSIC Bit8: PLL_MIPI Bit7: PLL_GPU Bit6: PLL_VIDEO1 Bit5: PLL_PERIPH0 Bit4: PLL_DDR0 Bit3: PLL_VE Bit2: PLL_VIDEO0 Bit1: PLL_AUDIO Bit0: PLL_CPUX

3.3.6. Programming Guidelines

3.3.6.1. PLL

- 1) In practical application, other PLLs doesn't support dynamic frequency scaling except for **PLL_CPUX** and **PLL_DDR1**;
- 2) After the **PLL_DDR0** frequency changes, the **20-bit** of **PLL_DDR0 Control Register** should be written 1 to make it valid;
- 3) After the **PLL_DDR1** frequency changes, the **30-bit** of **PLL_DDR1 Control Register** should be written 1 to make it valid;
- 4) When configured **PLL_MIPI**, LDO1 and LDO2 must be enable at first, and delay 100us, configure the division factor, then enable and delay 500us, **PLL_MIPI** can be output to use.

3.3.6.2. BUS

- 1) When setting the **Bus Clock**, you should set the division factor first, and after the division factor available, switch the clock source. The switching of clock source will be available after at least three clock cycles;
- 2) The **Bus Clock** should not be dynamically changed in most applications.

3.3.6.3. Clock Switch

Make sure that the clock source output is valid before the clock source switch, and then set a proper divide ratio; after the division factor becomes valid, switch the clock source.

3.3.6.4. Gating and reset

Make sure that the reset signal has been released before the release of module clock gating;

3.4. CPU Configuration

3.4.1. Overview

CPUCFG module is used to configure related CPU parameters, including power on, reset, cache, debug etc, and check the status of CPU. It will be used when you want to disable/enable the CPU, cluster switch, CPU status check, and debug, etc.

It features:

- Capable of CPU reset, including core reset, debug circuit rest, etc
- Capable of other CPU-related control, including interface control, CP15 control, and power control, etc
- Capable of checking CPU status, including idle status, SMP status, and interrupt status, etc

3.4.2. Block Diagram

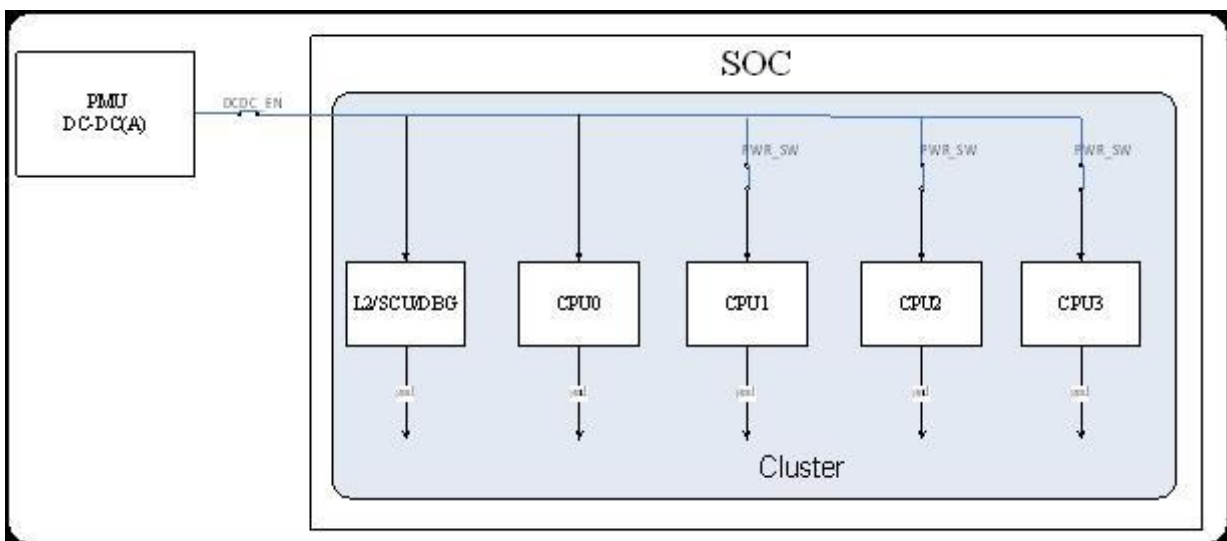

Figure 3-4. CPUCFG Block Diagram

The figure above lists the power domain of CPU reset. All power switch of CPU core are default to be closed. Since each CPU core and its appended circuits have the same power domain, the processor and related L1 cache, neon and vfp should be taken as a whole when it comes to the CPU core enable/disable.

3.4.3. Functionalities Description

3.4.3.1. Signal Description

For the detail of CPU Signal, please refer to **ARM Cortex-A53 TRM**.

3.4.3.2. L2 Idle Mode

When the L2 of Cluster needs to enter WFI mode, firstly make sure the CPU0/1/2/3 of Cluster enter WFI mode, which can be checked through **Cluster CPU Status Register**, and then pull the **ACINACTM** of Cluster high by writing related register bit to 1, and then check whether L2 enters idle status by checking whether the **STANDBYWFIL2** is high. Remember to set the **ACINACTM** to low when exiting the L2 idle mode.

3.4.3.3. CPU Reset System

The CPU reset includes **core reset**, **power-on reset** and **H_Reset**. And their scopes rank: **core reset** < **power-on Reset** < **H_Reset**. For the detail description, please refer to **3.4.5 Register Description**.

3.4.3.4. Operation Principle

The CPU-related operation needs proper configuration of CPUCFG related register, as well as related system control resource including BUS, clock ,reset and power control.

3.4.4. Register List

Module Name	Base Address
CPUCFG	0x01700C00

Register Name	Offset	Description
C_CTRL_REG0	0x0000	Cluster Control Register0
C_CTRL_REG1	0x0004	Cluster Control Register1
CACHE_CFG_REG0	0x0008	Cache parameters configuration register0
CACHE_CFG_REG1	0x000C	Cache parameters configuration register1
GENER_CTRL_REG0	0x0028	General Control Register0
C_CPU_STATUS	0x0030	Cluster CPU Status Register

L2_STATUS_REG	0x003C	L2 Status Register
C_RST_CTRL	0x0080	Cluster Reset Control Register
RVBARADDR0_L	0x00A0	Reset Vector Base Address Register0_L
RVBARADDR0_H	0x00A4	Reset Vector Base Address Register0_H
RVBARADDR1_L	0x00A8	Reset Vector Base Address Register1_L
RVBARADDR1_H	0x00AC	Reset Vector Base Address Register1_H
RVBARADDR2_L	0x00B0	Reset Vector Base Address Register2_L
RVBARADDR2_H	0x00B4	Reset Vector Base Address Register2_H
RVBARADDR3_L	0x00B8	Reset Vector Base Address Register3_L
RVBARADDR3_H	0x00BC	Reset Vector Base Address Register3_H

3.4.5. Register Description

3.4.5.1. Cluster Control Register0 (Default Value: 0x80000000)

Offset: 0x00			Register Name: C_CTRL_REG0
Bit	R/W	Default/Hex	Description
31	R/W	0x1	<p>SYSBAR_DISABLE. Disable broadcasting of barriers onto system bus: 0: Barriers are broadcast onto system bus, this requires an AMBA4 interconnect. 1: Barriers are not broadcast onto the system bus. This is compatible with an AXI3 interconnect.</p>
30	R/W	0x0	<p>BROADCAST_INNER. Enable broadcasting of Inner Shareable transactions: 0: Inner shareable transactions are not broadcasted externally. 1: Inner shareable transactions are broadcasted externally.</p>
29	R/W	0x0	<p>BROADCAST_OUTER. Enable broadcasting of outer shareable transactions: 0: Outer Shareable transactions are not broadcasted externally. 1: Outer Shareable transactions are broadcasted externally.</p>
28	R/W	0x0	<p>BROADCAST_CACHE_MAINT Enable broadcasting of cache maintenance operations to downstream caches: 0: Cache maintenance operations are not broadcasted to downstream caches. 1: Cache maintenance operations are broadcasted to downstream caches.</p>

27:24	R/W	0x0	AA64nAA32 Register width state.Determines which execution state the processor boots into after a cold reset. 0: AArch32 1: AArch64
23:10	/	/	/
11:8	R/W	0x0	CP15S_DISABLE. Disable write access to some secure CP15 register.
7:5	/	/	/
4	R/W	0x0	L2_RST_DISABLE. Disable automatic L2 cache invalidate at reset: 0: L2 cache is reset by hardware. 1: L2 cache is not reset by hardware.
3:0	/	/	/

3.4.5.2. Cluster Control Register1 (Default Value: 0x00000000)

Offset: 0x04			Register Name: C_CTRL_REG1
Bit	R/W	Default/Hex	Description
31:1	/	/	/
0	R/W	0x0	ACINACTM. Snoop interface is inactive and no longer accepting requests. 0: snoop interface is active 1: Snoop interface is inactive

3.4.5.3. Cache Parameter Control Register0 (Default Value: 0x22222222)

Offset: 0x08			Register Name: CACHE_CFG_REG0
Bit	R/W	Default/Hex	Description
31	/	/	/
30:28	R/W	0x2	L1SDT_DELAY
27	/	/	/
26:24	R/W	0x2	L1TLB_DELAY
23	/	/	/
22:20	R/W	0x2	BTAC_DELAY
19	/	/	/
18:16	R/W	0x2	L1DY_DELAY
15	/	/	/
14:12	R/W	0x2	L1DT_DELAY
11	/	/	/
10:8	R/W	0x2	L1DD_DELAY

7	/	/	/
6:4	R/W	0x2	L1IT_DELAY
3	/	/	/
2:0	R/W	0x2	L1ID_DELAY

3.4.5.4. Cache Parameter Control Register1 (Default Value: 0x02022020)

Offset: 0x0C			Register Name: CACHE_CFG_REG1
Bit	R/W	Default/Hex	Description
31:26	/	/	/
25:24	R/W	0x2	EMAW
23:19	/	/	/
18:16	R/W	0x2	EMA
15	/	/	/
14:12	R/W	0x2	L2V_DELAY
11:8	/	/	/
7	/	/	/
6:4	R/W	0x2	L2T_DELAY
3:0	/	/	/

3.4.5.5. General Control Register0 (Default Value: 0x00000010)

Offset: 0x28			Register Name: GENER_CTRL_REG0
Bit	R/W	Default/Hex	Description
31:25	/	/	/
24	R/W	0x0	EVENTI Event input for processor wake-up from WFE state.This bit must remain HIGH for at least one clock cycle to be visible by the cores.
23:20	R/W	0x0	EXM_CLR[3:0]
19:17	/	/	/
16	R/W	0x0	CLREXMONREQ Clearing of the external global exclusive monitor request.When this bit is asserted, it acts as a WFE wake-up event to all the cores in the MPCore device.
15:12	R/W	0x0	CRYPTODISABLE Disable the Cryptography Extensions.
11:9	/	/	/
8	R/W	0x0	L2FLUSHREQ L2 hardware flush request.
7:5	/	/	/
4	R/W	0x1	GICCDISABLE.

			Globally disables the CPU interface logic and routes the "External" signals directly to the processor: 0: Enable the GIC CPU interface logic. 1: Disable the GIC CPU interface logic.
3:0	/	/	/

3.4.5.6. Cluster CPU Status Register (Default Value: 0x000E0000)

Offset: 0x30			Register Name: C_CPU_STATUS
Bit	R/W	Default/Hex	Description
31:28	/	/	/
27:24	R	0x0	SMP Indicates whether a core is taking part in coherency. 0: Disable 1: Enable
23:20	/	/	/
19:16	R	0xE	STANDBYWFI. Indicates if a core is in WFI standby mode: 0: Processor not in WFI standby mode. 1: Processor in WFI standby mode
15:12	/	/	/
11:8	R	0x0	STANDBYWFE. Indicates if a core is in the WFE standby mode: 0: Processor not in WFE standby mode 1: Processor in WFE standby mode
7:1	/	/	/
0	R	0x0	STANDBYWFIL2. Indicates if the Cluster L2 memory system is in WFI standby mode. 0:active 1:idle

3.4.5.7. L2 Status Register(Default Value: 0x00000000)

Offset: 0x3C			Register Name: L2_STATUS_REG
Bit	R/W	Default/Hex	Description
31:11	/	/	/
10	R	0x0	L2FLUSHDONE L2 hardware flush complete
9	R	0x0	EVENTO Event output.This bit is asserted HIGH for 3 clock cycles when any core in the cluster executes an SEV instruction.

8	R	0x0	CLREXMONACK Clearing of the external global exclusive monitor acknowledge.
7:0	/	/	/

3.4.5.8. Cluster Reset Control Register (Default Value: 0x11101101)

Offset: 0x80			Register Name: C_RST_CTRL
Bit	R/W	Default/Hex	Description
31:29	/	/	/
28	R/W	0x1	DDR_RST AXI2MBUS logic circuit Reset. 0: assert 1: de-assert
27:25	/	/	/
24	R/W	0x1	SOC_DBG_RST. Cluster SOC Debug P_Reset. Clear this bit will reset the SOC Debug Bus Logic and it will auto change to 1 after 64 p_cycles. 0: assert 1: de-assert.
23:21	R/W	0x0	
20	R/W	0x1	MBIST_RST CPUBIST Reset. The reset signal for test. 0: assert 1: de-assert
19:16	R/W	0x0	/
15:13	/	/	/
12	R/W	0x1	HRESET. Cluster H_Reset. Reset all the Cluster Logic and Cluster Interface Logic. 0: assert 1: de-assert.
11:9	/	/	/
8	R/W	0x1	L2_RST. Cluster L2 Cache Reset 0: assert 1: de-assert.
7:4	/	/	/
3:0	R/W	0x1	CORE_RESET. Control a core reset assert. 0: assert 1: de-assert.

3.4.5.9. Reset Vector Base Address Register0_L (Default Value: 0x00000000)

Offset: 0xA0			Register Name: RVBARADDR0_L
Bit	R/W	Default/Hex	Description
31:2	R/W	0x0	RVBARDDR[31:2] Reset Vector Base Address[39:2] for executing in 64-bit state (AArch64) of CPU0.
1:0	/	/	/

3.4.5.10. Reset Vector Base Address Register0_H (Default Value: 0x00000000)

Offset: 0xA4			Register Name: RVBARADDR0_H
Bit	R/W	Default/Hex	Description
31:8	/	/	/
7:0	R/W	0x0	RVBARDDR[39:32] Reset Vector Base Address[39:2] for executing in 64-bit state (AArch64) of CPU0.

3.4.5.11. Reset Vector Base Address Register1_L (Default Value: 0x00000000)

Offset: 0xA8			Register Name: RVBARADDR1_L
Bit	R/W	Default/Hex	Description
31:2	R/W	0x0	RVBARDDR[31:2] Reset Vector Base Address[39:2] for executing in 64-bit state (AArch64) of CPU1.
1:0	/	/	/

3.4.5.12. Reset Vector Base Address Register1_H (Default Value: 0x00000000)

Offset: 0xAC			Register Name: RVBARADDR1_H
Bit	R/W	Default/Hex	Description
31:8	/	/	/
7:0	R/W	0x0	RVBARDDR[39:32] Reset Vector Base Address[39:2] for executing in 64-bit state (AArch64) of CPU1.

3.4.5.13. Reset Vector Base Address Register2_L (Default Value: 0x00000000)

Offset: 0xB0			Register Name: RVBARADDR2_L
Bit	R/W	Default/Hex	Description
31:2	R/W	0x0	RVBARDDR[31:2] Reset Vector Base Address[39:2] for executing in 64-bit state (AArch64) of CPU2.
1:0	/	/	/

3.4.5.14. Reset Vector Base Address Register2_H (Default Value: 0x00000000)

Offset: 0xB4			Register Name: RVBARADDR2_H
Bit	R/W	Default/Hex	Description
31:8	/	/	/
7:0	R/W	0x0	RVBARDDR[39:32] Reset Vector Base Address[39:2] for executing in 64-bit state (AArch64) of CPU2.

3.4.5.15. Reset Vector Base Address Register3_L (Default Value: 0x00000000)

Offset: 0xB8			Register Name: RVBARADDR3_L
Bit	R/W	Default/Hex	Description
31:2	R/W	0x0	RVBARDDR[31:2] Reset Vector Base Address[39:2] for executing in 64-bit state (AArch64) of CPU3.
1:0	/	/	/

3.4.5.16. Reset Vector Base Address Register3_H (Default Value: 0x00000000)

Offset: 0xBC			Register Name: RVBARADDR3_H
Bit	R/W	Default/Hex	Description
31:8	/	/	/
7:0	R/W	0x0	RVBARDDR[39:32] Reset Vector Base Address[39:2] for executing in 64-bit state (AArch64) of CPU3.

3.5. System Control

3.5.1. Overview

Area	Size(Bytes)
A1	32K
A2	64K
C	172K
CPUX I-Cache	32K (X=0,1,2,3)
CPUX D-Cache	32K (X=0,1,2,3)
CPU L2 Cache	512K
Total	1036K

3.5.2. System Control Register List

Module Name	Base Address
System Control	0x01C00000

Register Name	Offset	Description
VER_REG	0x24	Version Register
EMAC_CLK_REG	0x30	EMAC Clock Register

3.5.3. System Control Register Description

3.5.3.1. Version Register

Offset:0x24			Register Name: VER_REG
Bit	R/W	Default/Hex	Description
31:9	/	/	/
8	R	x	UBOOT_SEL_PAD_STA. U_boot Select Pin Status. 0: U_Boot; 1: Normal Boot.
7:0	R	0x0	VER_BITS. This read-only bit field always reads back the mask revision level of the chip.

3.5.3.2. EMAC Clock Register (Default Value: 0x00000000)

Offset:0x30			Register Name: EMAC_CLK_REG
Bit	R/W	Default/Hex	Description
31:14	/	/	/
13	R/W	0x0	RMII_EN 0 : Disable RMII Module 1 : Enable RMII Module When this bit assert, MII or RGMII interface is disabled(This means bit13 is prior to bit2)
12:10	R/W	0x0	ETXDC. Configure EMAC Transmit Clock Delay Chain.
9:5	R/W	0x0	ERXDC. Configure EMAC Receive Clock Delay Chain.
4	R/W	0x0	ERXIE Enable EMAC Receive Clock Invertor. 0: Disable 1: Enable
3	R/W	0x0	ETXIE Enable EMAC Transmit Clock Invertor. 0: Disable 1: Enable
2	R/W	0x0	EPIT EMAC PHY Interface Type 0: MII 1: RGMII
1:0	R/W	0x0	ETCS. EMAC Transmit Clock Source 00: Transmit clock source for MII 01: External transmit clock source for GMII and RGMII 10: Internal transmit clock source for GMII and RGMII 11: Reserved

3.6. Timer

3.6.1. Overview

Timer 0/1 can take their inputs from 32K or OSC24M. They provide the operating system's scheduler interrupt. It is designed to offer maximum accuracy and efficient management, even for systems with long or short response time. They provide 32-bit programmable overflow counter and work in auto-reload mode or no-reload mode. When the current value in [Timer 0 Current Value Register](#) or [Timer 1 Current Value Register](#) is counting down to zero, the timer will generate interrupt if set interrupt enable bit.

The watchdog is used to resume the controller operation when it had been disturbed by malfunctions such as noise and system errors. It features a down counter that allows a watchdog period of up to 16 seconds (512000 cycles). It can generate a general reset or interrupt request.

Audio-Video-Sync(AVS) counter is used to synchronize video and audio in the player.

The timer module includes the following features:

- 2 Timers for system scheduler counting using 24MHz or 32KHz clock
- Each Timer could general individual interrupt
- 1 Watchdog for resetting whole system or interrupt
- 2 AVS counters used for synchronize video and audio in the player

3.6.2. Block Diagram

Timer counter' clock input comes from one of the two clock sources that could be pre-scaled up to 128 division. In single mode, when current value is counted down to 0, enable bit would be cleared automatically and Timer stops working. But in continuous mode, Interval Value will be auto-reloaded into [Timer 0 Current Value Register](#)/[Timer 1 Current Value Register](#) and then counter counts from the new interval value again when current value is counted down to 0. Every time current value is counted down to 0, a pending will be generated. Pending could be sent to GIC or R_INTC only if IRQ enable bit is set.

Generally watchdog could not count down to 0 because it would be restart inside Interval Value. Otherwise the malfunction makes the watchdog counts down to 0 and a pending will be generated, which causes a reset([Watchdog Configuration Register](#) is configured for whole system) or an interrupt([Watchdog Configuration Register](#) is configured for only interrupt).

AVS has two counters which are both up-counted. The counter' clock source comes from 24MHz/Divisor_N and Divisor_N is set in [AVS Counter Divisor Register](#). AVS counter could be changed to pause or enable at any time,so are the Interval Value set in [AVS Counter 0 Register](#) or [AVS Counter 1 Register](#) and Divisor Value set in [AVS Counter Divisor Register](#). When you enable the AVS counter,it counts up from Interval Value until you

pause it. It doesn't general any pending.

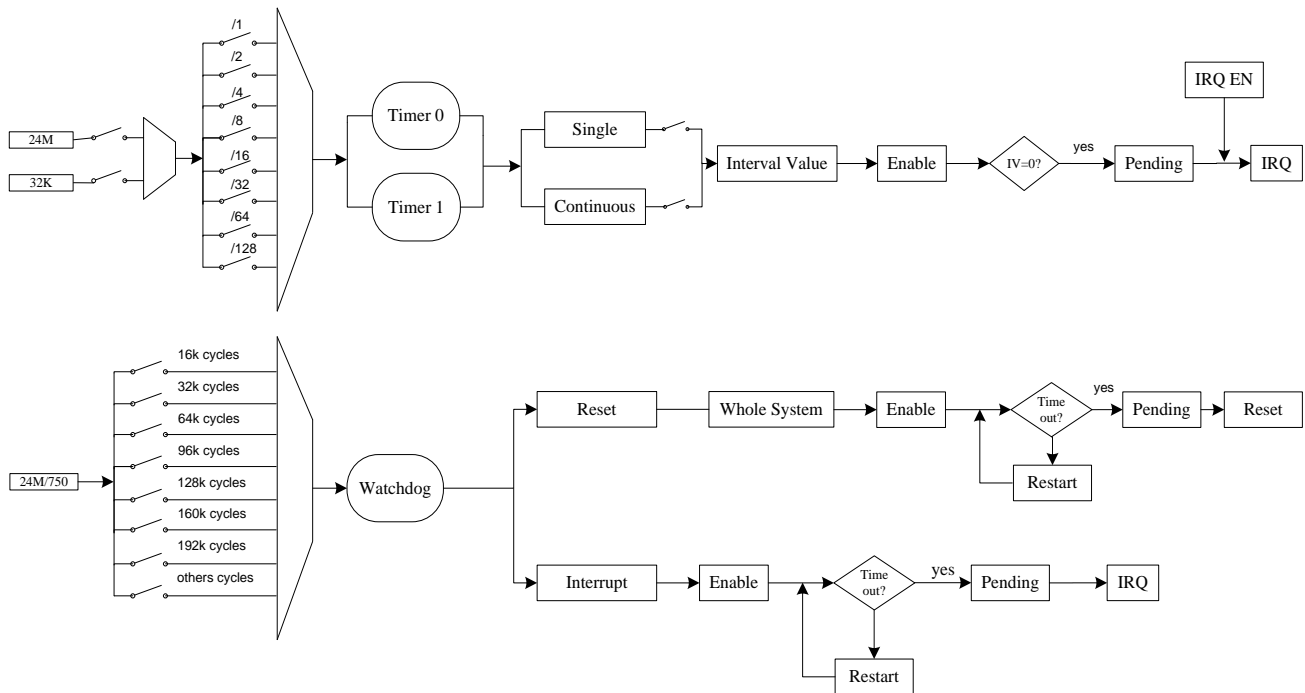

Figure 3-5. Timer Block Diagram

3.6.3. Operation Principle

3.6.3.1. Timer reload and enable bit

Generally the operation of setting both reload bit and enable bit and writing them into **Timer 0 Control Register/Timer 1 Control Register** moreover could cause a risk. It had better to enable Timer after Interval Value has been loaded into **Timer 0 Current Value Register/Timer 1 Current Value Register**. Only in timer pause time, when you hope that counter starts working from a new interval value, reload bit and enable bit should be set 1 and wrote into **TMRO_CTRL_REG/ TMR1_CTRL_REG** at the same time.

3.6.3.2. Timing requirement for Timer command

For reload and enable operation of Timer, it is necessary to wait some cycles between the same continuous operations. It indicates that from pause state to start or from start state to pause it has to wait for 2 cycles at lease. And to reload operation, it could not be implemented immediately again until the reload bit had been cleared automatically of the last operation.

3.6.3.3. Watchdog restart

Watchdog restart function should be enable inside Interval Value. Writing **Watchdog Restart** to 1 and **Watchdog Key Field** to 0xA57 at the same time make a restart, but writing **Watchdog Key Field** to other values is ignored.

3.6.4. Timer Register List

Module Name	Base Address
TIMER	0x01C20C00

Register Name	Offset	Description
TMR_IRQ_EN_REG	0x0	Timer IRQ Enable Register
TMR_IRQ_STA_REG	0x4	Timer Status Register
TMRO_CTRL_REG	0x10	Timer 0 Control Register
TMRO_INTV_VALUE_REG	0x14	Timer 0 Interval Value Register
TMRO_CUR_VALUE_REG	0x18	Timer 0 Current Value Register
TMR1_CTRL_REG	0x20	Timer 1 Control Register
TMR1_INTV_VALUE_REG	0x24	Timer 1 Interval Value Register
TMR1_CUR_VALUE_REG	0x28	Timer 1 Current Value Register
AVS_CNT_CTL_REG	0x80	AVS Control Register
AVS_CNT0_REG	0x84	AVS Counter 0 Register
AVS_CNT1_REG	0x88	AVS Counter 1 Register
AVS_CNT_DIV_REG	0x8C	AVS Divisor Register
WDOG0_IRQ_EN_REG	0xA0	Watchdog 0 IRQ Enable Register
WDOG0_IRQ_STA_REG	0xA4	Watchdog 0 Status Register
WDOG0_CTRL_REG	0xB0	Watchdog 0 Control Register
WDOG0_CFG_REG	0xB4	Watchdog 0 Configuration Register
WDOG0_MODE_REG	0xB8	Watchdog 0 Mode Register

3.6.5. Timer Register Description

3.6.5.1. Timer IRQ Enable Register (Default Value: 0x00000000)

Offset:0x0			Register Name: TMR_IRQ_EN_REG
Bit	R/W	Default/Hex	Description
31:2	/	/	/

1	R/W	0x0	TMR1_IRQ_EN. Timer 1 Interrupt Enable. 0: No effect; 1: Timer 1 Interval Value reached interrupt enable.
0	R/W	0x0	TMR0_IRQ_EN. Timer 0 Interrupt Enable. 0: No effect; 1: Timer 0 Interval Value reached interrupt enable.

3.6.5.2. Timer IRQ Status Register (Default Value: 0x00000000)

Offset:0x04			Register Name: TMR_IRQ_STA_REG
Bit	R/W	Default/Hex	Description
31:2	/	/	/
1	R/W	0x0	TMR1_IRQ_PEND. Timer 1 IRQ Pending. Set 1 to the bit will clear it. 0: No effect; 1: Pending, timer 1 interval value is reached.
0	R/W	0x0	TMR0_IRQ_PEND. Timer 0 IRQ Pending. Set 1 to the bit will clear it. 0: No effect; 1: Pending, timer 0 interval value is reached.

3.6.5.3. Timer 0 Control Register (Default Value: 0x00000004)

Offset:0x10			Register Name: TMR0_CTRL_REG
Bit	R/W	Default/Hex	Description
31:8	/	/	/
7	R/W	0x0	TMR0_MODE. Timer 0 mode. 0: Continuous mode. When interval value reached, the timer will not disable automatically. 1: Single mode. When interval value reached, the timer will disable automatically.
6:4	R/W	0x0	TMR0_CLK_PRES. Select the pre-scale of timer 0 clock source. 000: /1 001: /2 010: /4 011: /8 100: /16

			101: /32 110: /64 111: /128
3:2	R/W	0x1	TMRO_CLK_SRC. Timer 0 Clock Source. 00: 32K 01: OSC24M. 10: / 11: /
1	R/W	0x0	TMRO_RELOAD. Timer 0 Reload. 0: No effect 1: Reload timer 0 Interval value. After the bit is set, it can not be written again before it's cleared automatically.
0	R/W	0x0	TMRO_EN. Timer 0 Enable. 0: Stop/Pause 1: Start. When the timer is started, it will reload the interval value to internal register, and the current counter will count from interval value to 0. If the current counter does not reach the zero, the timer enable bit is set to "0", the current value counter will pause. At least wait for 2 cycles, the start bit can be set to 1. In timer pause state; the interval value register can be modified. If the timer is started again, and the Software hope the current value register to down-count from the new interval value, the reload bit and the enable bit should be set to 1 at the same time.

3.6.5.4. Timer 0 Interval Value Register

Offset:0x14			Register Name: TMRO_INTV_VALUE_REG
Bit	R/W	Default/Hex	Description
31:0	R/W	0x0	TMRO_INTV_VALUE. Timer 0 Interval Value.

Note:The value setting should consider the system clock and the timer clock source.

3.6.5.5. Timer 0 Current Value Register

Offset:0x18			Register Name: TMRO_CUR_VALUE_REG
Bit	R/W	Default/Hex	Description

31:0	R/W	0x0	TMR0_CUR_VALUE. Timer 0 Current Value.
------	-----	-----	---

Note: Timer0 current value is a 32-bit down-counter (from interval value to 0).

3.6.5.6. Timer 1 Control Register (Default Value: 0x00000004)

Offset:0x20			Register Name: TMR1_CTRL_REG
Bit	R/W	Default/Hex	Description
31:8	/	/	/
7	R/W	0x0	TMR1_MODE. Timer 1 mode. 0: Continuous mode. When interval value reached, the timer will not disable automatically. 1: Single mode. When interval value reached, the timer will disable automatically.
6:4	R/W	0x0	TMR1_CLK_PRE. Select the pre-scale of timer 1 clock source. 000: /1 001: /2 010: /4 011: /8 100: /16 101: /32 110: /64 111: /128
3:2	R/W	0x1	TMR1_CLK_SRC. 00: 32K 01: OSC24M. 10: / 11: /.
1	R/W	0x0	TMR1_RELOAD. Timer 1 Reload. 0: No effect 1: Reload timer 1 Interval value. After the bit is set, it can not be written again before it's cleared automatically.
0	R/W	0x0	TMR1_EN. Timer 1 Enable. 0: Stop/Pause 1: Start. If the timer is started, it will reload the interval value to internal register, and the current counter will count from interval value to 0. If the current counter does not reach the zero, the timer enable bit is set

			<p>to “0”, the current value counter will pause. At least wait for 2 cycles, the start bit can be set to 1.</p> <p>In timer pause state, the interval value register can be modified. If the timer is started again, and the Software hope the current value register to down-count from the new interval value, the reload bit and the enable bit should be set to 1 at the same time.</p>
--	--	--	---

3.6.5.7. Timer 1 Interval Value Register

Offset:0x24			Register Name: TMR1_INTV_VALUE_REG
Bit	R/W	Default/Hex	Description
31:0	R/W	0x0	TMR1_INTV_VALUE. Timer 1 Interval Value.

Note: The value setting should consider the system clock and the timer clock source.

3.6.5.8. Timer 1 Current Value Register

Offset:0x28			Register Name: TMR1_CUR_VALUE_REG
Bit	R/W	Default/Hex	Description
31:0	R/W	0x0	TMR1_CUR_VALUE. Timer 1 Current Value.

Note: Timer1 current value is a 32-bit down-counter (from interval value to 0).

3.6.5.9. AVS Counter Control Register (Default Value: 0x00000000)

Offset:0x80			Register Name: AVS_CNT_CTL_REG
Bit	R/W	Default/Hex	Description
31:10	/	/	/
9	R/W	0x0	AVS_CNT1_PS. Audio/Video Sync Counter 1 Pause Control 0: Not pause 1: Pause Counter 1.
8	R/W	0x0	AVS_CNT0_PS. Audio/Video Sync Counter 0 Pause Control 0: Not pause 1: Pause Counter 0.
7:2	/	/	/
1	R/W	0x0	AVS_CNT1_EN. Audio/Video Sync Counter 1 Enable/ Disable. The counter source is OSC24M.

			0: Disable 1: Enable.
0	R/W	0x0	AVS_CNT0_EN. Audio/Video Sync Counter 1 Enable/ Disable. The counter source is OSC24M. 0: Disable 1: Enable.

3.6.5.10. AVS Counter 0 Register (Default Value: 0x00000000)

Offset:0x84			Register Name: AVS_CNT0_REG
Bit	R/W	Default/Hex	Description
31:0	R/W	0x0	AVS_CNT0. Counter 0 for Audio/ Video Sync Application The high 32 bits of the internal 33-bits counter register. The initial value of the internal 33-bits counter register can be set by software. The LSB bit of the 33-bits counter register should be zero when the initial value is updated. It will count from the initial value. The initial value can be updated at any time. It can also be paused by setting AVS_CNT0_PS to '1'. When it is paused, the counter won't increase.

3.6.5.11. AVS Counter 1 Register (Default Value: 0x00000000)

Offset:0x88			Register Name: AVS_CNT1_REG
Bit	R/W	Default/Hex	Description
31:0	R/W	0x0	AVS_CNT1. Counter 1 for Audio/ Video Sync Application The high 32 bits of the internal 33-bits counter register. The initial value of the internal 33-bits counter register can be set by software. The LSB bit of the 33-bits counter register should be zero when the initial value is updated. It will count from the initial value. The initial value can be updated at any time. It can also be paused by setting AVS_CNT1_PS to '1'. When it is paused, the counter won't increase.

3.6.5.12. AVS Counter Divisor Register (Default Value: 0x05DB05DB)

Offset:0x8C			Register Name: AVS_CNT_DIV_REG
Bit	R/W	Default/Hex	Description
31:28	/	/	/
27:16	R/W	0x5DB	AVS_CNT1_D.

			<p>Divisor N for AVS Counter 1 AVS CN1 CLK=24MHz/Divisor_N1. Divisor N1 = Bit [27:16] + 1. The number N is from 1 to 0x7ff. The zero value is reserved. The internal 33-bits counter engine will maintain another 12-bits counter. The 12-bits counter is used for counting the cycle number of one 24Mhz clock. When the 12-bits counter reaches (\geq N) the divisor value, the internal 33-bits counter register will increase 1 and the 12-bits counter will reset to zero and restart again.</p>
15:12	/	/	/
11:0	R/W	0x5DB	<p>AVS_CNT0_D. Divisor N for AVS Counter 0 AVS CN0 CLK=24MHz/Divisor_N0. Divisor N0 = Bit [11:0] + 1 The number N is from 1 to 0x7ff. The zero value is reserved. The internal 33-bits counter engine will maintain another 12-bits counter. The 12-bits counter is used for counting the cycle number of one 24Mhz clock. When the 12-bits counter reaches (\geq N) the divisor value, the internal 33-bits counter register will increase 1 and the 12-bits counter will reset to zero and restart again.</p>

Note: Divisor N can be configured by software at any time.

3.6.5.13. Watchdog IRQ Enable Register (Default Value: 0x00000000)

Offset:0xA0			Register Name: WDOG_IRQ_EN_REG
Bit	R/W	Default/Hex	Description
31:1	/	/	/
0	R/W	0x0	<p>WDOG_IRQ_EN. Watchdog Interrupt Enable. 0: No effect 1: Watchdog interrupt enable.</p>

3.6.5.14. Watchdog Status Register (Default Value: 0x00000000)

Offset:0xA4			Register Name: WDOG_IRQ_STA_REG
Bit	R/W	Default/Hex	Description
31:1	/	/	/
0	R/W	0x0	<p>WDOG_IRQ_PEND. Watchdog n IRQ Pending. Set 1 to the bit will clear it. 0: No effect, 1: Pending, watchdog interval value is reached.</p>

3.6.5.15. Watchdog Control Register (Default Value: 0x00000000)

Offset:0xB0			Register Name: WDOG_CTRL_REG
Bit	R/W	Default/Hex	Description
31:13	/	/	/
12:1	R/W	0x0	WDOG_KEY_FIELD. Watchdog Key Field. Should be written at value 0xA57. Writing any other value in this field aborts the write operation.
0	R/W	0x0	WDOG_RSTART. Watchdog Restart. 0: No effect, 1: Restart watchdog.

3.6.5.16. Watchdog Configuration Register (Default Value: 0x00000001)

Offset:0xB4			Register Name: WDOG_CFG_REG
Bit	R/W	Default/Hex	Description
31:2	/	/	/
1:0	R/W	0x1	WDOG_CONFIG. Watchdog generates a reset signal 00: / 01: To whole system 10: Only interrupt 11: /

3.6.5.17. Watchdog Mode Register (Default Value: 0x00000000)

Offset:0xB8			Register Name: WDOG_MODE_REG
Bit	R/W	Default/Hex	Description
31:8	/	/	/
7:4	R/W	0x0	WDOG_INTV_VALUE. Watchdog Interval Value Watchdog clock source is $OSC24M / 750$. If the clock source is turned off, Watchdog will not work. 0000: 16000 cycles (0.5s) 0001: 32000 cycles (1s) 0010: 64000 cycles (2s) 0011: 96000 cycles (3s) 0100: 128000 cycles (4s)

			0101: 160000 cycles (5s) 0110: 192000 cycles (6s) 0111: 256000 cycles (8s) 1000: 320000 cycles (10s) 1001: 384000 cycles (12s) 1010: 448000 cycles (14s) 1011: 512000 cycles (16s) others: /
3:1	/	/	/
0	R/W	0x0	WDOG_EN. Watchdog Enable. 0: No effect; 1: Enable watchdog.

3.6.6. Programming Guidelines

3.6.6.1. Timer

Take making a Timer0 1ms delay for an example, 24M clock source, single mode and 2 pre-scale will be selected in the instance.

```
writel(0x2EE0, TMRO_INTV_VALUE_REG); //Set interval value
writel(0x94, TMRO_CTRL_REG); //Select Single mode,24MHz clock source,2 pre-scale
writel(readl(TMRO_CTRL_REG)|(1<<1), TMRO_CTRL_REG); //Set Reload bit
while((readl(TMRO_CTRL_REG)>>1)&1); //Waiting Reload bit turns to 0
writel(readl(TMRO_CTRL_REG)|(1<<0), TMRO_CTRL_REG); //Enable Timer0
```

3.6.6.2. Watchdog

In the following instance making configurations for Watchdog: configurate clock source as 24M/750, configurate Interval Value as 1s and configurate Watchdog Configuration as To whole system. This instance indicates that restarting Watchdog after 0.5s inside Interval Value.

```
writel(0x1, WDOG_CFG_REG); //To whole system
writel(0x10, WDOG_MODE_REG); //Interval Value set 1s
writel(readl(WDOG_MODE_REG)|(1<<0), WDOG_MODE_REG); //Enable Watchdog
delay_ms(500); //Delay 500ms
writel(readl(WDOG_CTRL_REG)|(0xA57<<1)|(1<<0), WDOG_CTRL_REG); //Writel 0xA57 at Key Field and
Restart Watchdog
.....After 1s, Watchdog will general a pending, which would reset the system.....
```

3.7. R_Trusted Watchdog Timer

3.7.1. Overview

The r_trusted watchdog timer is primarily used to protect the trusted world operations from denial of service when secure services are dependent to the RichOS scheduler. For example, if the trusted world is not entered after a defined time limit the SoC is re-started to perform an authentication of the system.

The r_trusted watchdog timer can also be used to mask the real cause of a security error thanks to the delayed warm reset it generates.

3.7.2. Block Diagram

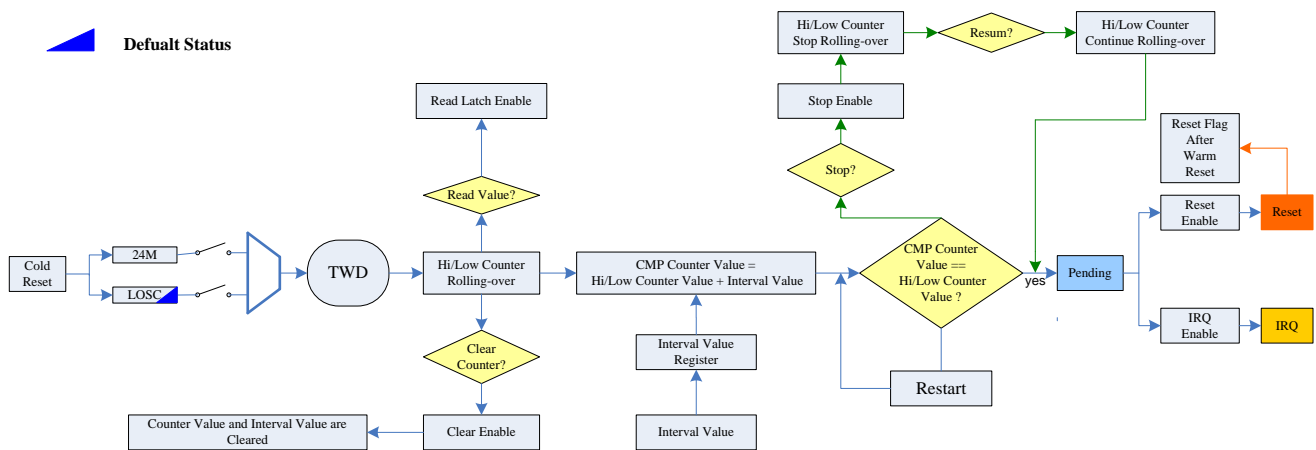

Figure 3-6. TWD Block Diagram

The trusted watchdog timer must always be running when the SoC wakes up from cold reset and can be refreshed, suspended, or reset only by secure accesses. And a clock of at least 32 kHz is used when the device is not a power saving cycles.

3.7.3. Functionalities Description

3.7.3.1. TWD Reset

The trusted watchdog timer is able to generate a SoC warm reset after a duration programmed into the timer or set by default in hardware. And the flag indicating the occurrence of a watchdog triggered warm reset has

occurred since the last cold reset.

Clock sources driving the watchdog timer must be controlled or managed by a trusted entity. This means that non-trusted world accesses are not permitted to turn on, turn off or modify the characteristics of clock source. The **clear enable** bit will reset relevant bits in **R_TWD_CTRL_REG**, except the reset flag.

3.7.3.2. NV-Counter

After a firmware image is validated, the image revision number taken from the certificate extension field, for example, *Trusted Firmware NV-Counter* is compared with the corresponding NV-Counter stored in hardware. If the value is:

- Less than the associated NV-Counter, then the authentication fail.
- Identical to the NV-Counter, then the authentication is successful.
- More than the NV-Counter, then the authentication are successful and the NV-Counter is updated.

The 2³² monotonic counter does not need to be e-Fuses, but it does need to be fully secure. Using the SoC embedded NVM, or external secure element, or a trusted register, which is always on power.

The **Secure Storage NV-Counter Register** is used for protecting the trusted world Secure Storage (SST) file from replay attacks, since SST contains subsidiary relay attacks protection counters for each Trusted Application. Four 32-bit counters are used for counting 2³² states for synchronizing data stores against replay attacks. These counters are optionally required since they can be handled by a Trusted OS service using the secure storage at boot time or using eMMC v4.4x Replay Protected Memory Block (RPMB).

3.7.4. TWD Register List

Module Name	Base Address
TWD	0x01F01800

Register Name	Offset	Description
R_TWD_STA_REG	0x0	R_TWD Status Register
R_TWD_CTRL_REG	0x10	R_TWD Control Register
R_TWD_RESTA_REG	0x14	R_TWD Restart Register
R_TWD_LOW_COUNTER_REG	0x20	R_TWD Low Counter Register
R_TWD_HI_COUNTER_REG	0x24	R_TWD High Counter Register
R_TWD_INTV_VAL_REG	0x30	R_TWD Interval Value Register
R_TWD_LOW_CMP_REG	0x40	R_TWD Low Counter Compare Register
R_TWD_HI_CMP_REG	0x44	R_TWD High Counter Compare Register
SST_NV_COUNTER_REG	0x100	Secure Storage NV-Counter Register
SYN_DATA_COUNTER_REG0	0x110	Synchronize Data Counter Register 0

SYN_DATA_COUNTER_REG1	0x114	Synchronize Data Counter Register 1
SYN_DATA_COUNTER_REG2	0x118	Synchronize Data Counter Register 2
SYN_DATA_COUNTER_REG3	0x11c	Synchronize Data Counter Register 3

3.7.5. R_TWD Register Description

3.7.5.1. R_TWD Status Register (Default Value: 0x00000000)

Offset: 0x0000			Register Name: R_TWD_STATUS_REG
Bit	R/W	Default/Hex	Description
31:1	/	/	/
0	R/W	0x0	R_TWD_PEND_FLAG. Trusted watchdog timer's interrupt pending. Set 1 to the bit will clear it. 0: No effect 1: Pending

3.7.5.2. R_TWD Control Register (Default Value: 0x00000000)

Offset: 0x0010			Register Name: R_TWD_CTRL_REG
Bit	R/W	Default/Hex	Description
31	R/W	0x0	CNT64_CLK_SRC_SEL. 64-bit counter clock source select. 0: LOSC. 1: OSC24M.
30:10	/	/	/
9	R/W	0x0	R_TWD_RESET_EN. R_TWD reset enable. 0: Reset disable. 1: Reset enable.
8	R/W	0x0	R_TWD_INT_EN. R_TWD Interrupt Enable. 0: Interrupt disable. 1: Interrupt enable.
7:2	/	/	/
1	R/W	0x0	R_TWD_STOP_EN. R_TWD stop enable. 0: Resume rolling-over. 1: Stop rolling-over.
0	R/W	0x0	R_TWD_CLR_EN. R_TWD clear enable.

			<p>0: No effect.</p> <p>1: To clear relevant registers and it will change to zero after the registers are cleared.</p>
--	--	--	--

3.7.5.3. R_TWD Restart Register (Default Value: 0x00000000)

Offset: 0x0014			Register Name: R_TWD_RESTART_REG
Bit	R/W	Default/Hex	Description
31:28	/	/	/
27:16	WO	0x0	R_TWD_RESTART_KEYFILED. Should be written at value 0xD14. Writing any other value in this field aborts the write operation.
15:1	/	/	/
0	WO	0x0	R_TWD_RESTART_EN. If writing '1' in this bit, the value of Counter Compare Register would change. 0: No effect. 1: Restart enable.

3.7.5.4. R_TWD Low Counter Register (Default Value: 0x00000000)

Offset: 0x0020			Register Name: R_TWD_LOW_CNT_REG
Bit	R/W	Default/Hex	Description
31:0	RO	0x0	R_TWD_LOW_CNT. The TWD low 32-bit counter.

3.7.5.5. R_TWD High Counter Register (Default Value: 0x00000000)

Offset: 0x0024			Register Name: R_TWD_HIGH_CNT_REG
Bit	R/W	Default/Hex	Description
31:0	RO	0x0	R_TWD_HIGH_CNT. The TWD high 32-bit counter.

3.7.5.6. R_TWD Interval Value Register (Default Value: 0x00000000)

Offset: 0x0030			Register Name: R_TWD_INTV_VAL_REG
Bit	R/W	Default/Hex	Description
31:0	R/W	0x0	R_TWD_INTV_VAL.

			The TWD interval value.
--	--	--	-------------------------

3.7.5.7. R_TWD Low Counter Compare Register (Default Value: 0x00000000)

Offset: 0x0040			Register Name: R_TWD_LOW_CNT_CMP_REG
Bit	R/W	Default/Hex	Description
31:0	RO	0x0	R_TWD_LOW_CMP. The TWD low 32-bit compare counter.

3.7.5.8. R_TWD High Counter Compare Register (Default Value: 0x00000000)

Offset: 0x0044			Register Name: R_TWD_HIGH_CNT_CMP_REG
Bit	R/W	Default/Hex	Description
31:0	RO	0x0	R_TWD_HIGH_CMP. The TWD high 32-bit compare counter.

3.7.5.9. Secure Storage NV-Counter Register (Default Value: 0x00000000)

Offset: 0x0100			Register Name: SST_NV_CNT_REG
Bit	R/W	Default/Hex	Description
31:0	R/W	0x0	SST_NV_CNT. This counter protects the trusted world Secure Storage file from replay attacks.

3.7.5.10. Synchronize Data Counter Register 0 (Default Value: 0x00000000)

Offset: 0x0110			Register Name: SYN_DATA_CNT_REG0
Bit	R/W	Default/Hex	Description
31:0	R/W	0x0	SYN_DATA_CNT0. This counter is used for synchronizing data stores against replay attacks.

3.7.5.11. Synchronize Data Counter Register 1 (Default Value: 0x00000000)

Offset: 0x0114			Register Name: SYN_DATA_CNT_REG1
Bit	R/W	Default/Hex	Description
31:0	R/W	0x0	SYN_DATA_CNT1. This counter is used for synchronizing data stores against replay attacks.

3.7.5.12. Synchronize Data Counter Register 2 (Default Value: 0x00000000)

Offset: 0x0118			Register Name: SYN_DATA_CNT_REG2
Bit	R/W	Default/Hex	Description
31:0	R/W	0x0	SYN_DATA_CNT2. This counter is used for synchronizing data stores against replay attacks.

3.7.5.13. Synchronize Data Counter Register 3 (Default Value: 0x00000000)

Offset: 0x011C			Register Name: SYN_DATA_CNT_REG3
Bit	R/W	Default/Hex	Description
31:0	R/W	0x0	SYN_DATA_CNT3. This counter is used for synchronizing data stores against replay attacks.

3.8. RTC

3.8.1. Overview

The real time clock (RTC) is for calendar usage. It is built around a 30-bit counter and used to count elapsed time in YY-MM-DD and HH-MM-SS. The unit can be operated by the backup battery while the system power is off. It has a built-in leap year generator and a independent power pin (RTC_VIO).

The alarm generates an alarm signal at a specified time in the power-off mode or normal operation mode. In normal operation mode, both the alarm interrupt and the power management wakeup are activated. In power-off mode, the power management wakeup signal is activated. In this section, there are two kinds of alarm. Alarm 0 is a general alarm, its counter is based on second. Alarm 1 is a weekly alarm, its counter is based on the real time.

The 32768Hz oscillator is used only to provide a low power, accurate reference for the RTC.

General Purpose Register can be flag register, and it will save the value all the time when the VDD_RTC is not power off.

3.8.2. RTC Register List

Module Name	Base Address
RTC	0x01F00000

Register Name	Offset	Description
LOSC_CTRL_REG	0x0	Low Oscillator Control Register
LOSC_AUTO_SWT_STA_REG	0x4	LOSC Auto Switch Status Register
INTOSC_CLK_PRESCAL_REG	0x8	Internal OSC Clock Prescaler Register
RTC_YY_MM_DD_REG	0x10	RTC Year-Month-Day Register
RTC_HH_MM_SS_REG	0x14	RTC Hour-Minute-Second Register
ALARM0_COUNTER_REG	0x20	Alarm 0 Counter Register
ALARM0_CUR_VLU_REG	0x24	Alarm 0 Counter Current Value Register
ALARM0_ENABLE_REG	0x28	Alarm 0 Enable Register
ALARM0_IRQ_EN	0x2C	Alarm 0 IRQ Enable Register
ALARM0_IRQ_STA_REG	0x30	Alarm 0 IRQ Status Register
ALARM1_WK_HH_MM-SS	0x40	Alarm 1 Week HMS Register
ALARM1_ENABLE_REG	0x44	Alarm 1 Enable Register
ALARM1_IRQ_EN	0x48	Alarm 1 IRQ Enable Register
ALARM1_IRQ_STA_REG	0x4C	Alarm 1 IRQ Status Register
ALARM_CONFIG_REG	0x50	Alarm Config Register

LOSC_OUT_GATING_REG	0x60	LOSC output gating register
GP_DATA_REG	0x100 + N*0x4	General Purpose Register (N=0~3)
GPL_HOLD_OUTPUT_REG	0x180	GPL Hold Output Register
VDD_RTC_REG	0x190	VDD RTC Regulate Register
IC_CHARA_REG	0x1F0	IC Characteristic Register
Crypt Configuration Register	0x210	CRY_CONFIG_REG
Crypt Key Register	0x214	CRY_KEY_REG
Crypt Enable Register	0x218	CRY_CONFIG_REG

3.8.3. RTC Register Description

3.8.3.1. LOSC Control Register (Default Value: 0x00004000)

Offset:0x0			Register Name: LOSC_CTRL_REG
Bit	R/W	Default/Hex	Description
31:16	W	0x0	KEY_FIELD. Key Field. This field should be filled with 0x16AA, and then the bit 0 can be written with the new value.
15	/	/	/
14	R/W	0x1	LOSC_AUTO_SWT_EN. LOSC auto switch enable. 0: Disable, 1: Enable.
13:10	/	/	/
9	R/W	0x0	ALM_DDHHMMSS_ACCE. ALARM DD-HH-MM-SS access. After writing the ALARM DD-HH-MM-SS register, this bit is set and it will be cleared until the real writing operation is finished.
8	R/W	0x0	RTC_HHMMSS_ACCE. RTC HH-MM-SS access. After writing the RTC HH-MM-SS register, this bit is set and it will be cleared until the real writing operation is finished. After writing the RTC HH-MM-SS register, the HH-MM-SS register will be refreshed for at most one second.
7	R/W	0x0	RTC_YMMDD_ACCE. RTC YY-MM-DD access. After writing the RTC YY-MM-DD register, this bit is set and it will be cleared until the real writing operation is finished. After writing the RTC YY-MM-DD register, the YY-MM-DD register will be refreshed for at most one second.
6:4	/	/	/

3:2	R/W	0x0	EXT_LOSC_GSM. External 32768Hz Crystal GSM. 00: low 01:/ 10:/ 11:high
1	/	/	/
0	R/W	0x0	LOSC_SRC_SEL. LOSC Clock source Select. 'N' is the value of Internal OSC Clock Prescaler register. 0: InternalOSC /32/ N 1: External 32.768KHz OSC.

Note1: Any bit of [9:7] is set, the RTC HH-MM-SS, YY-MM-DD and ALARM DD-HH-MM-SS register can't be written.

Note2: Internal OSC is about 16MHz.

3.8.3.2. LOSC Auto Switch Status Register (Default Value: 0x00000000)

Offset:0x4			Register Name: LOSC_AUTO_SWT_STA_REG
Bit	R/W	Default/Hex	Description
31:2	/	/	/
1	R/W	0x0	LOSC_AUTO_SWT_PEND. LOSC auto switch pending. 0: No effect 1: Auto switches pending Set 1 to this bit will clear it.
0	RO	0x0	LOSC_SRC_SEL_STA. Checking LOSC Clock Source Status. 'N' is the value of Internal OSC Clock Prescaler register. 0: InternalOSC / N 1: External 32.768KHz OSC

3.8.3.3. Internal OSC Clock Prescaler Register (Default Value: 0x0000000F)

Offset:0x8			Register Name: INTOSC_CLK_PRESCAL_REG
Bit	R/W	Default/Hex	Description
31:5	/	/	/
4:0	R/W	0xF	INTOSC_CLK_PRESCAL. Internal OSC Clock Prescaler value N. 00000: 1 00001: 2

			00010: 3 11111: 32
--	--	--	--------------------------------

3.8.3.4. RTC YY-MM-DD Register (Default Value: 0x00000000)

Offset:0x10			Register Name: RTC_YY_MM_DD_REG
Bit	R/W	Default/Hex	Description
31:23	/	/	/
22	R/W	0x0	LEAP. Leap Year. 0: not, 1: Leap year. This bit can not set by hardware. It should be set or clear by software.
21:16	R/W	x	YEAR. Year. Range from 0~63.
15:12	/	/	/
11:8	R/W	x	MONTH. Month. Range from 1~12.
7:5	/	/	/
4:0	R/W	x	DAY. Day. Range from 1~31.

Note1: If the written value is not from 1 to 31 in Day Area, it turns into 31 automatically. Month Area and Year Area are similar to Day Area.

Note2: The number of days in different month may be different.

3.8.3.5. RTC HH-MM-SS Register (Default Value: 0x00000000)

Offset:0x14			Register Name: RTC_HH_MM_SS_REG
Bit	R/W	Default/Hex	Description
31:29	R/W	0x0	WK_NO. Week number. 000: Monday 001: Tuesday 010: Wednesday 011: Thursday 100: Friday 101: Saturday 110: Sunday

			111: /
28:21	/	/	/
20:16	R/W	x	HOUR. Range from 0~23
15:14	/	/	/
13:8	R/W	x	MINUTE. Range from 0~59
7:6	/	/	/
5:0	R/W	x	SECOND. Range from 0~59

Note: If the written value is not from 0 to 59 in Second Area, it turns into 59 automatically. Minute Area and Hour Area are similar to Second Area.

3.8.3.6. Alarm 0 Counter Register (Default Value: 0x00000000)

Offset:0x20			Register Name: ALARM0_COUNTER_REG
Bit	R/W	Default/Hex	Description
31:0	R/W	0x0	ALARM0_COUNTER. Alarm 0 Counter is Based on Second.

Note: If the second is set to 0, it will be 1 second in fact.

3.8.3.7. Alarm 0 Current Value Register

Offset:0x24			Register Name: ALARM0_CUR_VLU_REG
Bit	R/W	Default/Hex	Description
31:0	RO	x	ALARM0_CUR_VLU. Check Alarm 0 Counter Current Values.

Note: If the second is set to 0, it will be 1 second in fact.

3.8.3.8. Alarm 0 Enable Register (Default Value: 0x00000000)

Offset:0x28			Register Name: ALARM0_ENABLE_REG
Bit	R/W	Default/Hex	Description
31:1	/	/	/
0	R/W	0x0	ALM_0_EN Alarm 0 Enable. If this bit is set to “1”, the Alarm 0 Counter register’s valid bits will down

			count to zero, and the alarm pending bit will be set to "1". 0: Disable 1: Enable
--	--	--	---

3.8.3.9. Alarm 0 IRQ Enable Register (Default Value: 0x00000000)

Offset:0x2C			Register Name: ALARM0_IRQ_EN
Bit	R/W	Default/Hex	Description
31:1	/	/	/
0	R/W	0x0	ALARM0_IRQ_EN. Alarm 0 IRQ Enable. 0: Disable 1: Enable

3.8.3.10. Alarm 0 IRQ Status Register (Default Value: 0x00000000)

Offset:0x30			Register Name: ALARM0_IRQ_STA_REG
Bit	R/W	Default/Hex	Description
31:1	/	/	/
0	R/W	0x0	ALARM0_IRQ_PEND. Alarm 0 IRQ Pending bit. 0: No effect 1: Pending, alarm 0 counter value is reached If alarm 0 irq enable is set to 1, the pending bit will be sent to the interrupt controller.

3.8.3.11. Alarm 1 Week HH-MM-SS Register (Default Value: 0x00000000)

Offset:0x40			Register Name: ALARM1_WK_HH_MM_SS
Bit	R/W	Default/Hex	Description
31:21	/	/	/
20:16	R/W	x	HOUR. Range from 0~23.
15:14	/	/	/
13:8	R/W	x	MINUTE. Range from 0~59.
7:6	/	/	/
5:0	R/W	x	SECOND. Range from 0~59.

Note: If the written value is not from 0 to 59 in Second Area, it turns into 59 automatically. Minute Area and

Hour Area are similar to Second Area.

3.8.3.12. Alarm 1 Enable Register (Default Value: 0x00000000)

Offset:0x44			Register Name: ALARM1_EN_REG
Bit	R/W	Default/Hex	Description
31:7	/	/	/
6	R/W	0x0	<p>WK6_ALM1_EN. Week 6 (Sunday) Alarm 1 Enable.</p> <p>0: Disable 1: Enable</p> <p>If this bit is set to “1”, only when the bit[20:0] of Alarm 1 Week HH-MM-SS Register are equal to the bit[20:0] of RTC HH-MM-SS Register and the bit [31:29] of RTC HH-MM-SS Register is 6, the week 6 alarm irq pending bit will be set to “1”.</p>
5	R/W	0x0	<p>WK5_ALM1_EN. Week 5 (Saturday) Alarm 1 Enable.</p> <p>0: Disable 1: Enable</p> <p>If this bit is set to “1”, only when the bit[20:0] of Alarm 1 Week HH-MM-SS Register are equal to the bit[20:0] of RTC HH-MM-SS Register and the bit [31:29] of RTC HH-MM-SS Register is 5, the week 5 alarm irq pending bit will be set to “1”.</p>
4	R/W	0x0	<p>WK4_ALM1_EN. Week 4 (Friday) Alarm 1 Enable.</p> <p>0: Disable 1: Enable</p> <p>If this bit is set to “1”, only when the bit[20:0] of Alarm 1 Week HH-MM-SS Register are equal to the bit[20:0] of RTC HH-MM-SS Register and the bit [31:29] of RTC HH-MM-SS Register is 4, the week 4 alarm irq pending bit will be set to “1”.</p>
3	R/W	0x0	<p>WK3_ALM1_EN. Week 3 (Thursday) Alarm 1 Enable.</p> <p>0: Disable 1: Enable</p> <p>If this bit is set to “1”, only when the bit[20:0] Alarm 1 Week HH-MM-SS Register valid bits are equal to the bit[20:0] of RTC HH-MM-SS Register and the bit [31:29] of RTC HH-MM-SS Register is 3, the week 3 alarm irq pending bit will be set to “1”.</p>
2	R/W	0x0	<p>WK2_ALM1_EN. Week 2 (Wednesday) Alarm 1 Enable.</p> <p>0: Disable</p>

			<p>1: Enable</p> <p>If this bit is set to “1”, only when the bit[20:0] Alarm 1 Week HH-MM-SS Register valid bits are equal to the bit[20:0] of RTC HH-MM-SS Register and the bit [31:29] of RTC HH-MM-SS Register is 2, the week 2 alarm irq pending bit will be set to “1”.</p>
1	R/W	0x0	<p>WK1_ALM1_EN.</p> <p>Week 1 (Tuesday) Alarm 1 Enable.</p> <p>0: Disable</p> <p>1: Enable</p> <p>If this bit is set to “1”, only when the bit[20:0] Alarm 1 Week HH-MM-SS Register valid bits are equal to the bit[20:0] of RTC HH-MM-SS Register and the bit [31:29] of RTC HH-MM-SS Register is 1, the week 1 alarm irq pending bit will be set to “1”.</p>
0	R/W	0x0	<p>WK0_ALM1_EN.</p> <p>Week 0 (Monday) Alarm 1 Enable.</p> <p>0: Disable</p> <p>1: Enable</p> <p>If this bit is set to “1”, only when the bit[20:0] Alarm 1 Week HH-MM-SS Register valid bits are equal to the bit[20:0] of RTC HH-MM-SS Register and the bit [31:29] of RTC HH-MM-SS Register is 0, the week 0 alarm irq pending bit will be set to “1”.</p>

3.8.3.13. Alarm 1 IRQ Enable Register (Default Value: 0x00000000)

Offset:0x48			Register Name: ALARM1_IRQ_EN
Bit	R/W	Default/Hex	Description
31:1	/	/	/
0	R/W	0x0	<p>ALARM1_IRQ_EN.</p> <p>Alarm 1 IRQ Enable.</p> <p>0: Disable</p> <p>1: Enable</p>

3.8.3.14. Alarm 1 IRQ Status Register (Default Value: 0x00000000)

Offset:0x4C			Register Name: ALARM1_IRQ_STA_REG
Bit	R/W	Default/Hex	Description
31:1	/	/	/
0	R/W	0x0	<p>ALARM1_WEEK_IRQ_PEND.</p> <p>Alarm 1 Week (0/1/2/3/4/5/6) IRQ Pending.</p> <p>0: No effect</p> <p>1: Pending, week counter value is reached</p>

			If alarm 1 week irq enable is set to 1, the pending bit will be sent to the interrupt controller.
--	--	--	---

3.8.3.15. Alarm Config Register (Default Value: 0x00000000)

Offset:0x50			Register Name: ALARM_CONFIG_REG
Bit	R/W	Default/Hex	Description
31:1	/	/	/
0	R/W	0x0	ALARM_WAKEUP. Configuration of alarm wake up output. 0: Disable alarm wake up output 1: Enable alarm wake up output

3.8.3.16. LOSC Output Gating Register (Default Value: 0x00000000)

Offset:0x60			Register Name: LOSC_OUT_GATING_REG
Bit	R/W	Default/Hex	Description
31:1	/	/	/
0	R/W	0x0	LOSC_OUT_GATING. Configuration of LOSC output, and no LOSC output by default. 0: Enable LOSC output gating 1: Disable LOSC output gating

3.8.3.17. General Purpose Register (Default Value: 0x00000000)

Offset:0x100+N *0x4 (N=0~7)			Register Name: GP_DATA_REGn
Bit	R/W	Default/Hex	Description
31:0	R/W	0x0	GP_DATA. Data [31:0].

Note: General purpose register 0~7 value can be stored if the VCC-RTC is larger than 1.0v.

3.8.3.18. GPL Hold Output Register (Default Value: 0x00000000)

Offset:0x180			Register Name: GPL_HOLD_OUTPUT_REG
Bit	R/W	Default/Hex	Description
31:12	/	/	/

11	R/W	0x0	<p>GPL11_HOLD_OUTPUT.</p> <p>Hold the output of GPIOL11 when system's power is changing. The output must be low level (0) or high level (1) or High-Z; any other outputs may not hold on.</p> <p>0: Hold disable 1: Hold enable</p>
10	R/W	0x0	<p>GPL10_HOLD_OUTPUT.</p> <p>Hold the output of GPIOL10 when system's power is changing. The output must be low level (0) or high level (1) or High-Z; any other outputs may not hold on.</p> <p>0: Hold disable 1: Hold enable</p>
9	R/W	0x0	<p>GPL9_HOLD_OUTPUT.</p> <p>Hold the output of GPIOL9 when system's power is changing. The output must be low level (0) or high level (1) or High-Z; any other outputs may not hold on.</p> <p>0: Hold disable 1: Hold enable</p>
8	R/W	0x0	<p>GPL8_HOLD_OUTPUT.</p> <p>Hold the output of GPIOL8 when system's power is changing. The output must be low level (0) or high level (1) or High-Z; any other outputs may not hold on.</p> <p>0: Hold disable 1: Hold enable</p>
7	R/W	0x0	<p>GPL7_HOLD_OUTPUT.</p> <p>Hold the output of GPIOL7 when system's power is changing. The output must be low level (0) or high level (1) or High-Z; any other outputs may not hold on.</p> <p>0: Hold disable 1: Hold enable</p>
6	R/W	0x0	<p>GPL6_HOLD_OUTPUT.</p> <p>Hold the output of GPIOL6 when system's power is changing. The output must be low level (0) or high level (1) or High-Z; any other outputs may not hold on.</p> <p>0: Hold disable 1: Hold enable</p>
5	R/W	0x0	<p>GPL5_HOLD_OUTPUT.</p> <p>Hold the output of GPIOL5 when system's power is changing. The output must be low level (0) or high level (1) or High-Z; any other outputs may not hold on.</p> <p>0: Hold disable 1: Hold enable</p>
4	R/W	0x0	<p>GPL4_HOLD_OUTPUT.</p> <p>Hold the output of GPIOL4 when system's power is changing. The</p>

			<p>outputs must be low level (0) or high level (1) or High-Z; any other output may not hold on.</p> <p>0: Hold disable 1: Hold enable</p>
3	R/W	0x0	<p>GPL3_HOLD_OUTPUT.</p> <p>Hold the output of GPIOL3 when system's power is changing. The output must be low level (0) or high level (1) or High-Z; any other outputs may not hold on.</p> <p>0: Hold disable 1: Hold enable</p>
2	R/W	0x0	<p>GPL2_HOLD_OUTPUT.</p> <p>Hold the output of GPIOL2 when system's power is changing. The output must be low level (0) or high level (1) or High-Z; any other outputs may not hold on.</p> <p>0: Hold disable 1: Hold enable</p>
1	R/W	0x0	<p>GPL1_HOLD_OUTPUT.</p> <p>Hold the output of GPIOL1 when system's power is changing. The output must be low level (0) or high level (1) or High-Z; any other outputs may not hold on.</p> <p>0: Hold disable 1: Hold enable</p>
0	R/W	0x0	<p>GPL0_HOLD_OUTPUT.</p> <p>Hold the output of GPIOL0 when system's power is changing. The output must be low level (0) or high level (1) or High-Z; any other outputs may not hold on.</p> <p>0: Hold disable 1: Hold enable</p>

3.8.3.19. VDD RTC Regulation Register (Default Value: 0x00000004)

Offset:0x190			Register Name: VDD_RTC_REG
Bit	R/W	Default/Hex	Description
31:3	/	/	/
2:0	R/W	0x100	<p>VDD_RTC_REGU.</p> <p>These bits are useful for regulating the RTC_VIO from 0.7v to 1.4v, and the regulation step is 0.1v.</p> <p>000: 0.7v 001: 0.8v 010: 0.9v 011: 1.0v 100: 1.1v 101: 1.2v</p>

			110: 1.3v 111: 1.4v
--	--	--	------------------------

3.8.3.20. IC Characteristic Register (Default Value: 0x00000000)

Offset:0x1F0			Register Name: IC_CHARA_REG
Bit	Read/Write	Default/Hex	Description
31:16	R/W	0x0	IC_CHARA. Key Field. Should be written at value 0x16AA. Writing any other value in this field aborts the write operation.
15:0	R/W	0x0	ID_DATA. Return 0x16AA only if the KEY_FIELD is set as 0x16AA when read those bits, otherwise return 0x0.

3.8.3.21. Crypt Configuration Register (Default Value: 0x00000000)

Offset:0x210			Register Name: CRY_CONFIG_REG
Bit	Read/Write	Default/Hex	Description
31:16	/	/	/
15:0	R/W	0x0	KEY_FIELD Key Field

3.8.3.22. Crypt Key Register (Default Value: 0x00000000)

Offset:0x214			Register Name: CRY_KEY_REG
Bit	Read/Write	Default/Hex	Description
31:0	R/W	0x0	CRY_KEY Crypt Key

3.8.3.23. Crypt Enable Register (Default Value: 0x00000000)

Offset:0x218			Register Name: CRY_CONFIG_REG
Bit	Read/Write	Default/Hex	Description
31:1	/	/	/
0	R/W	0x0	CRY_EN Crypt enable

3.9. High-speed Timer

3.9.1. Overview

High Speed Timer' clock source is fixed to AHBCLK, which is much higher than OSC24M and so this kind of timer is called High Speed Timer. Compared with other timers, High Speed Timer calculates much more accurately. When the relevant bit in the Control Register is set 1, hstimer goes into the test mode, which is used to System Simulation. While the current value in both LO and HI Current Value Register are counting down to zero, the timer will generate interrupt if set interrupt enable bit.

The High Speed Timer includes the following features:

- 1 HSTimer with individual 56-bit counter
- HSTimer could generate a pending
- Clock source is synchronized with AHB clock, which means calculating much more accurate than other timers
- Support Test Mode for System Simulation

3.9.2. Operation Principle

3.9.2.1. HSTimer clock gating and software reset

By default the HSTimer clock gating is mask. When it is necessary to use HSTimer, it's clock gating should be open in **Bus Clock Gating Register0** and then de-assert the software reset in **Bus Software Reset Register 0** on CCU module. If it is no need to use HSTimer, both the gating bit and software reset bit should be set 0.

3.9.2.2. HSTimer reload bit

Differing from the reload of Timer, when interval value is reloaded into **HS Timer Current Value Lo Register** and **HS Timer Current Value Hi Register**, the **Reload** bit would not turn to 0 automatically until you clear it. If software hopes the **HS Timer Current Value Lo Register** and **HS Timer Current Value Hi Register** to down-count from the new **Interval Value** in pause status, the **Reload** bit and the **Enable** bit should be written 1 at the same time.

3.9.3. HSTimer Block Diagram

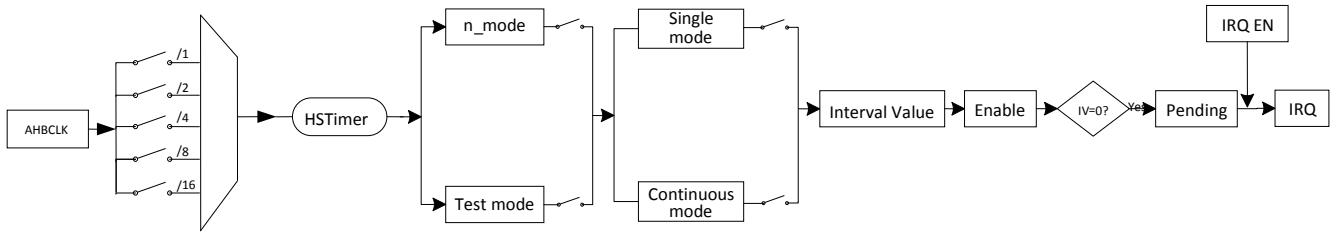

Figure 3-7. HSTimer function structure and work flow

HSTimer has two work modes and two count modes. n_mode is used for normal counting and Test mode is used in System Simulation. Each work mode has the two count mode: Single mode and Continuous mode. These two count modes have the same principle with Timers', which means when Current Value counts down to 0, HSTimer will be disable in Single mode ,but HSTimer will not be disable and counts from Interval value again in Continuous mode. About HSTimer 56-bit counter, it is combined with a high 24-bit counter([HS Timer Current Value Hi Register](#)) and a low 32-bit counter([HS Timer Current Value Lo Register](#)).

3.9.4. HSTimer Register List

Module Name	Base Address
High Speed Timer	0x01C60000

Register Name	Offset	Description
HS_TMR_IRQ_EN_REG	0x00	HS Timer IRQ Enable Register
HS_TMR_IRQ_STAS_REG	0x04	HS Timer Status Register
HS_TMR_CTRL_REG	0x10	HS Timer Control Register
HS_TMR_INTV_LO_REG	0x14	HS Timer Interval Value Low Register
HS_TMR_INTV_HI_REG	0x18	HS Timer Interval Value High Register
HS_TMR_CURNT_LO_REG	0x1C	HS Timer Current Value Low Register
HS_TMR_CURNT_HI_REG	0x20	HS Timer Current Value High Register

3.9.5. HSTimer Register Description

3.9.5.1. HS Timer IRQ Enable Register (Default Value: 0x00000000)

Offset:0x0			Register Name: HS_TMR_IRQ_EN_REG
Bit	R/W	Default/Hex	Description

31:1	/	/	/
0	R/W	0x0	HS_TMR_INT_EN. High Speed Timer Interrupt Enable. 0: No effect; 1: High Speed Timer Interval Value reached interrupt enable.

3.9.5.2. HS Timer IRQ Status Register (Default Value: 0x00000000)

Offset:0x4			Register Name: HS_TMR_IRQ_STAS_REG
Bit	R/W	Default/Hex	Description
31:1	/	/	/
0	R/W	0x0	HS_TMR_IRQ_PEND. High Speed Timer IRQ Pending. Set 1 to the bit will clear it. 0: No effect; 1: Pending, High speed timer interval value is reached.

3.9.5.3. HS Timer Control Register (Default Value: 0x00000000)

Offset:0x10			Register Name: HS_TMR_CTRL_REG
Bit	R/W	Default/Hex	Description
31	R/W	0x0	HS_TMR_TEST. High speed timer test mode. In test mode, the low register should be set to 0x1, the high register will down counter. The counter needs to be reloaded. 0: normal mode; 1: test mode.
30:8	/	/	/
7	R/W	0x0	HS_TMR_MODE. High Speed Timer mode. 0: Continuous mode. When interval value reached, the timer will not disable automatically. 1: Single mode. When interval value reached, the timer will disable automatically.
6:4	R/W	0x0	HS_TMR_CLK Select the pre-scale of the high speed timer clock sources. 000: /1 001: /2 010: /4 011: /8 100: /16 101: /

			110: / 111: /
3:2	/	/	/
1	R/W	0x0	HS_TMR_RELOAD. High Speed Timer Reload. 0: No effect 1: Reload High Speed Timer Interval Value.
0	R/W	0x0	HS_TMR_EN. High Speed Timer Enable. 0: Stop/Pause 1: Start. If the timer is started, it will reload the interval value to internal register, and the current counter will count from interval value to 0. If the current counter does not reach the zero, the timer enable bit is set to "0", the current value counter will pause. At least wait for 2 cycles, the start bit can be set to 1. In timer pause state, the interval value register can be modified. If the timer is started again, and the Software hope the current value register to down-count from the new interval value, the reload bit and the enable bit should be set to 1 at the same time.

3.9.5.4. HS Timer Interval Value Lo Register

Offset:0x14			Register Name: HS_TMR_INTV_LO_REG
Bit	R/W	Default/Hex	Description
31:0	R/W	x	HS_TMR_INTV_VALUE_LO. High Speed Timer Interval Value [31:0].

3.9.5.5. HS Timer Interval Value Hi Register

Offset:0x18			Register Name: HS_TMR_INTV_HI_REG
Bit	R/W	Default/Hex	Description
31:24	/	/	/
23:0	R/W	x	HS_TMR_INTV_VALUE_HI. High Speed Timer Interval Value [55:32].

Note:The interval value register is a 56-bit register. When read or write the interval value, the Lo register should be read or write first. And the Hi register should be written after the Lo register.

3.9.5.6. HS Timer Current Value Lo Register

Offset:0x1C			Register Name: HS_TMR_CURNT_LO_REG
Bit	R/W	Default/Hex	Description
31:0	R/W	x	HS_TMR_CUR_VALUE_LO. High Speed Timer Current Value [31:0].

3.9.5.7. HS Timer Current Value Hi Register

Offset:0x20			Register Name: HS_TMR_CURNT_HI_REG
Bit	R/W	Default/Hex	Description
31:24	/	/	/
23:0	R/W	x	HS_TMR_CUR_VALUE_HI. High Speed Timer Current Value [55:32].

Note1:HSTimer current value is a 56-bit down-counter (from interval value to 0).

Note2:The current value register is a 56-bit register. When read or write the current value, the Lo register should be read or write first.

3.9.6. Programming Guidelines

Take making a 1us delay using HSTimer for an instance as follow, AHB1CLK will be configured as 100MHz and n_mode, Single mode and 2 pre-scale will be selected in this instance.

```
writel(0x0, HS_TMR_INTV_HI_REG); //Set interval value Hi 0x0
writel(0x32, HS_TMR_INTV_LO_REG); //Set interval value Lo 0x32
writel(0x90, HS_TMR_CTRL_REG); //Select n_mode,2 pre-scale,single mode
writel(readl(HS_TMR_CTRL_REG)|(1<<1), HS_TMR_CTRL_REG); //Set Reload bit
writel(readl(HS_TMR_CTRL_REG)|(1<<0), HS_TMR_CTRL_REG); //Enable HSTimer
While(!(readl(HS_TMR_IRQ_STAS_REG)&1)); //Wait for HSTimer to generate pending
Writel(1, HS_TMR_IRQ_STAS_REG); //Clear HSTimer pending
```

3.10. PWM

3.10.1. Overview

The output of the PWM is a toggling signal whose frequency and duty cycle can be modulated by its programmable registers. Each channel has a dedicated internal 16-bit up counter. If the counter reaches the value stored in **PWM Channel 0 Period Register**, it resets. At the beginning of a count period cycle, the PWMOUT is set to active state and count from 0x0.

The PWM includes the following features:

- Support outputting 2 kinds of waveform: continuous waveform and pulse waveform
- 0% to 100% adjustable duty cycle
- 0Hz to 24MHz output frequency

3.10.2. PWM Block Diagram

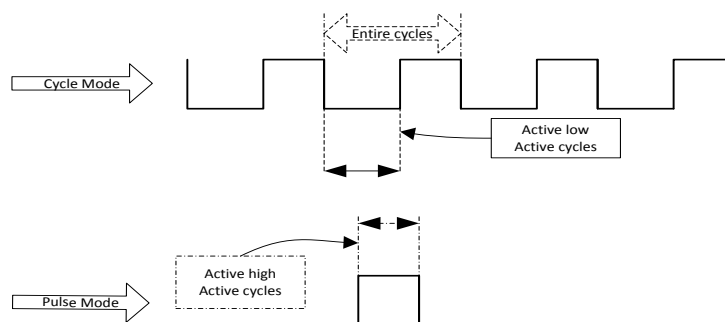

Figure 3-8. PWM Block Diagram

The PWM divider divides the clock (24MHz) by 1-64 according to the pre-scalar bits in the PWM control register. The PWM output Frequency can be divided by 65536 at most. In PWM **cycle mode**, the output will be a square waveform; the frequency is set to the period register. In PWM **pulse mode**, the output will be a positive pulse or a negative pulse.

In **cycle mode** PWM outputs continuous waveform and in **pulse mode** it outputs a pulse waveform. Each PWM channel has 2 16-bit up counters existing in corresponding Period Register, whose [31:16] bits indicate one 16-bit up counter for counting **entire cycles** and [15:0] bits indicate the other 16-bit up counter for counting **active cycles**.

3.10.3. PWM Register List

Module Name	Base Address
PWM	0x01C21400

Register Name	Offset	Description
PWM_CH_CTRL	0x00	PWM Control Register
PWM_CH0_PERIOD	0x04	PWM Channel 0 Period Register

3.10.4. PWM Register Description

3.10.4.1. PWM Control Register(Default Value: 0x00000000)

Offset:0x0			Register Name: PWM_CTRL_REG
Bit	R/W	Default/Hex	Description
31:29	/	/	/.
28	RO	0x0	PWM0_RDY. PWM0 period register ready. 0: PWM0 period register is ready to write, 1: PWM0 period register is busy.
27:10	/	/	/
9	R/W	0x0	PWM0_BYPASS. PWM CH0 bypass enable. If the bit is set to 1, PWM0's output is OSC24MHz. 0: disable, 1: enable.
8	R/W	0x0	PWM_CH0_PUL_START. PWM Channel 0 pulse output start. 0: no effect, 1: output 1 pulse. The pulse width should be according to the period 0 register[15:0],and the pulse state should be according to the active state. After the pulse is finished,the bit will be cleared automatically.
7	R/W	0x0	PWM_CHANNEL0_MODE. 0: cycle mode, 1: pulse mode.
6	R/W	0x0	SCLK_CH0_GATING. Gating the Special Clock for PWM0(0: mask, 1: pass).
5	R/W	0x0	PWM_CH0_ACT_STA. PWM Channel 0 Active State. 0: Low Level,

			1: High Level.
4	R/W	0x0	PWM_CH0_EN. PWM Channel 0 Enable. 0: Disable, 1: Enable.
3:0	R/W	0x0	PWM_CH0_PRESCAL. PWM Channel 0 Prescaler. These bits should be setting before the PWM Channel 0 clock gate on. 0000: /120 0001: /180 0010: /240 0011: /360 0100: /480 0101: / 0110: / 0111: / 1000: /12k 1001: /24k 1010: /36k 1011: /48k 1100: /72k 1101: / 1110: / 1111: /1

3.10.4.2. PWM Channel 0 Period Register

Offset:0x4			Register Name: PWM_CH0_PERIOD
Bit	R/W	Default/Hex	Description
31:16	R/W	x	PWM_CH0_ENTIRE_CYS Number of the entire cycles in the PWM clock. 0 = 1 cycle 1 = 2 cycles N = N+1 cycles If the register need to be modified dynamically, the PCLK should be faster than the PWM CLK (PWM CLK = 24MHz/pre-scale).
15:0	R/W	x	PWM_CH0_ENTIRE_ACT_CYS Number of the active cycles in the PWM clock. 0 = 0 cycle 1 = 1 cycles N = N cycles

3.11. DMA

3.11.1. Overview

There are 8 DMA channels in the chip. Each DMA channel can generate interrupts. According to different pending status, the referenced DMA channel generates corresponding interrupt. And, the configuration information of every DMA channel are storing in the DDR or SRAM. When start a DMA transferring, the **DMA Channel Descriptor Address Register** contains the address information in the DDR or SRAM, where has the relevance configuration information of the DMA transferring.

3.11.2. Functionalities Description

3.11.2.1. Block Diagram

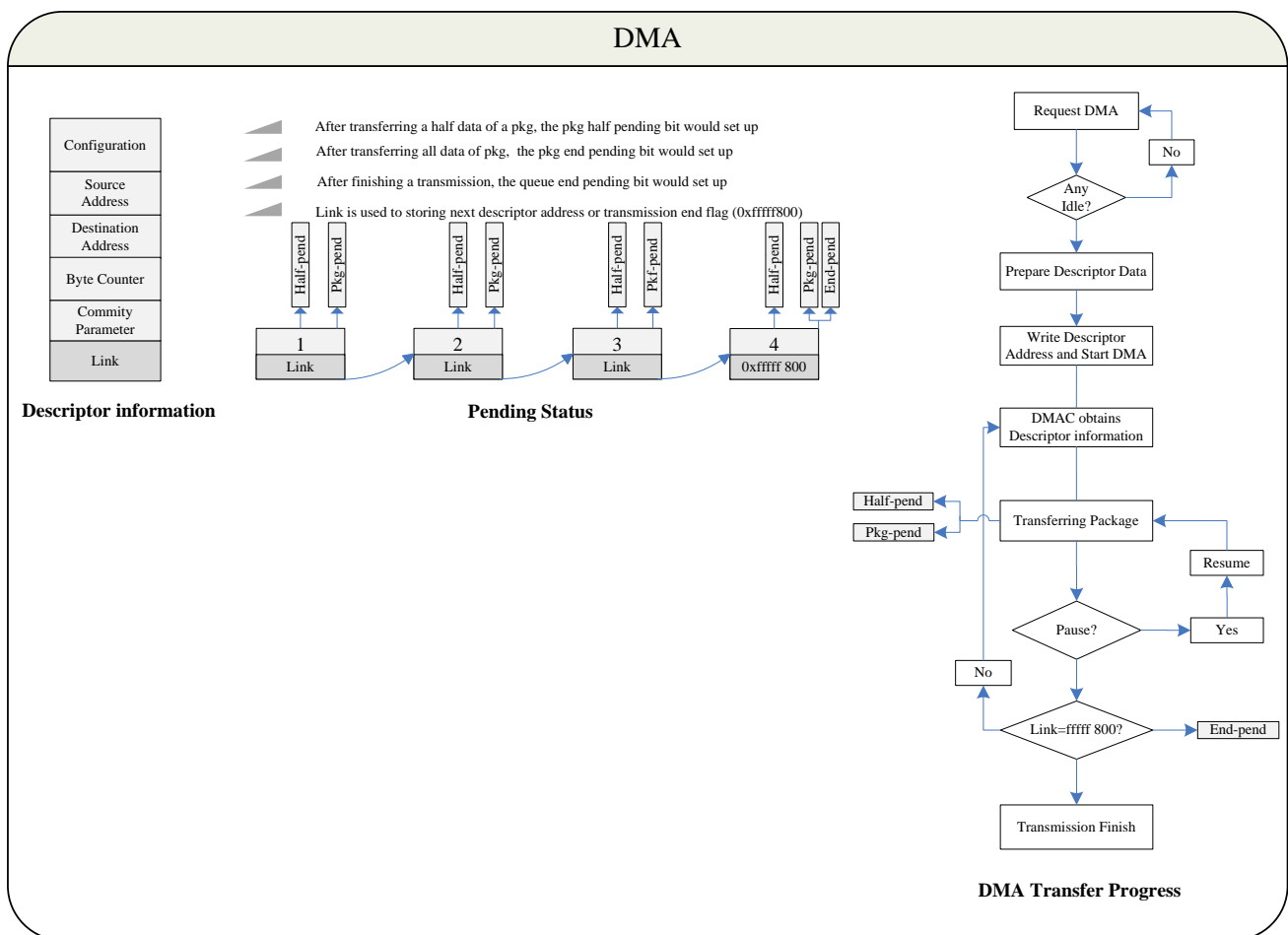

Figure 3-9. DMA Block Diagram

3.11.2.2. DRQ Type and Corresponding Relation

Table 3-1. DMA DRQ Table

Source DRQ Type		Destination DRQ Type	
Port NO.	Module Name	Port NO.	Module Name
Port 0	SRAM	Port 0	SRAM
Port 1	SDRAM	Port 1	SDRAM
Port 2	/	Port 2	OWA_TX
Port 3	I2S/PCM_0_RX	Port 3	I2S/PCM_0_TX
Port 4	I2S/PCM_1_RX	Port 4	I2S/PCM_1_TX
Port 5	NAND	Port 5	NAND
Port 6	UART0_RX	Port 6	UART0_TX
Port 7	UART1_RX	Port 7	UART1_TX
Port 8	UART2_RX	Port 8	UART2_TX
Port 9	UART3_RX	Port 9	UART3_TX
Port 10	UART4_RX	Port 10	UART4_TX
Port 11	/	Port 11	/
Port 12	/	Port 12	/
Port 13	/	Port 13	/
Port 14	/	Port 14	/
Port 15	Audio Codec	Port 15	Audio Codec
Port 16	/	Port 16	/
Port 17	USB OTG_EP1	Port 17	USB OTG_EP1
Port 18	USB OTG_EP2	Port 18	USB OTG_EP2
Port 19	USB OTG_EP3	Port 19	USB OTG_EP3
Port20	USB OTG_EP4	Port 20	USB OTG_EP4
Port 21	USB OTG_EP5	Port 21	USB OTG_EP5
Port 22	/	Port 22	/
Port 23	SPI0_RX	Port 23	SPI0_TX
Port 24	SPI1_RX	Port 24	SPI1_TX
Port 25		Port 25	
Port 26		Port 26	
Port 27		Port 27	I2S/PCM_2_TX
Port 28		Port 28	
Port 29		Port 29	
Port 30		Port 30	

3.11.2.3. DMA Descriptor

In this section, the DMA descriptor registers will be introduced in detail.

When starting a DMA transmission, the module data are transferred as packages, which have the link data

information. And, by reading the **DMA Status Register**, the status of a DMA channel could be known. Reading back the **DMA Channel Descriptor Address Register**, the value is the link data in the transferring package. If only the value is equal to 0x1ffff800, then it can be regarded as NULL, which means the package is the last package in this DMA transmission. Otherwise, the value means the start address of the next package. And **DMA Channel Descriptor Address Register** can be changed during a package transferring.

When transferring the half of a package, the relevant pending bit will be set up automatically, and if the corresponding interrupt is enabled, DMA generates an interrupt to the system. The similar thing would occur when transferring a package completely. Meanwhile, if DMA have transferred the last package in the data, the relevant pending bit would be set up, and generates an interrupt if the corresponding interrupt is enabled. The flow-process diagram is showed in **Block Diagram** section.

During a DMA transmission, the configuration could be obtained via **DMA Channel Configuration Register**. And, behind the address of the config register in DDR or SRAM, there are some registers including other information of a DMA transmission. The structure chart is showed in **Block Diagram** section. Also, other information of a transferring data can be obtained by reading the **DMA Channel Current Source Address Register**, **DMA Channel Current Destination Address Register** and **DMA Channel Byte Counter Left Register**. The configuration must be word-aligning.

The transferring data would be paused when setting up the relevant Pause Register, if coming up emergency. And the pausing data could be presumable when set 0 to the same bit in Pause Register.

3.11.3. DMA Register List

Module Name	Base Address
DMA	0x01C02000

Register Name	Offset	Description
DMA_IRQ_EN_REG	0x00	DMA IRQ Enable Register
DMA_IRQ_PEND_REG	0x10	DMA IRQ Pending Register
DMA_SEC_REG	0x20	DMA Security Register
DMA_AUTO_GATE_REG	0x28	DMA Auto Gating Register
DMA_STA_REG	0x30	DMA Status Register
DMA_EN_REG	0x100+N*0x40	DMA Channel Enable Register (N=0~7)
DMA_PAU_REG	0x100+N*0x40+0x4	DMA Channel Pause Register (N=0~7)
DMA_DESC_ADDR_REG	0x100+N*0x40+0x8	DMA Channel Start Address Register (N=0~7)
DMA_CFG_REG	0x100+N*0x40+0xC	DMA Channel Configuration Register (N=0~7)
DMA_CUR_SRC_REG	0x100+N*0x40+0x10	DMA Channel Current Source Register

		(N=0~7)
DMA_CUR_DEST_REG	0x100+N*0x40+0x14	DMA Channel Current Destination Register (N=0~7)
DMA_BCNT_LEFT_REG	0x100+N*0x40+0x18	DMA Channel Byte Counter Left Register (N=0~7)
DMA_PARA_REG	0x100+N*0x40+0x1C	DMA Channel Parameter Register (N=0~7)
DMA Mode Register	0x100+N*0x40+0x28	DMA_MODE_REG (N=0~7)
DMA_FDESC_ADDR_REG	0x100+N*0x40+0x2C	DMA Formar Descriptor Address Register (N=0~7)
DMA_PKG_NUM_REG	0x100+N*0x40+0x30	DMA Package Number Register (N=0~7)

3.11.4. DMA Register Description

3.11.4.1. DMA IRQ Enable Register (Default Value: 0x00000000)

Offset: 0x0000			Register Name: DMA_IRQ_EN_REG
Bit	R/W	Default/Hex	Description
31	/	/	/
30	R/W	0x0	DMA7_QUEUE_IRQ_EN DMA 7 Queue End Transfer Interrupt Enable. 0: Disable, 1: Enable.
29	R/W	0x0	DMA7_PKG_IRQ_EN DMA 7 Package End Transfer Interrupt Enable. 0: Disable, 1: Enable.
28	R/W	0x0	DMA7_HLAF_IRQ_EN DMA 7 Half Package Transfer Interrupt Enable. 0: Disable, 1: Enable.
27	/	/	/
26	R/W	0x0	DMA6_QUEUE_IRQ_EN DMA 6 Queue End Transfer Interrupt Enable. 0: Disable, 1: Enable.
25	R/W	0x0	DMA6_PKG_IRQ_EN DMA 6 Package End Transfer Interrupt Enable. 0: Disable, 1: Enable.
24	R/W	0x0	DMA6_HLAF_IRQ_EN DMA 6 Half Package Transfer Interrupt Enable. 0: Disable, 1: Enable.
23	/	/	/

22	R/W	0x0	DMA5_QUEUE_IRQ_EN DMA 5 Queue End Transfer Interrupt Enable. 0: Disable, 1: Enable.
21	R/W	0x0	DMA5_PKG_IRQ_EN DMA 5 Package End Transfer Interrupt Enable. 0: Disable, 1: Enable.
20	R/W	0x0	DMA5_HLAF_IRQ_EN DMA 5 Half package Transfer Interrupt Enable. 0: Disable, 1: Enable.
19	/	/	/
18	R/W	0x0	DMA4_QUEUE_IRQ_EN DMA 4 Queue End Transfer Interrupt Enable. 0: Disable, 1: Enable.
17	R/W	0x0	DMA4_PKG_IRQ_EN DMA 4 Package End Transfer Interrupt Enable. 0: Disable, 1: Enable.
16	R/W	0x0	DMA4_HLAF_IRQ_EN DMA 4 Half Package Transfer Interrupt Enable. 0: Disable, 1: Enable.
15	/	/	/
14	R/W	0x0	DMA3_QUEUE_IRQ_EN DMA 3 Queue End Transfer Interrupt Enable. 0: Disable, 1: Enable.
13	R/W	0x0	DMA3_PKG_IRQ_EN DMA 3 Package End Transfer Interrupt Enable. 0: Disable, 1: Enable.
12	R/W	0x0	DMA3_HLAF_IRQ_EN DMA 3 Half Package Transfer Interrupt Enable. 0: Disable, 1: Enable.
11	/	/	/
10	R/W	0x0	DMA2_QUEUE_IRQ_EN DMA 2 Queue End Transfer Interrupt Enable. 0: Disable, 1: Enable.
9	R/W	0x0	DMA2_PKG_IRQ_EN DMA 2 Package End Transfer Interrupt Enable. 0: Disable, 1: Enable.
8	R/W	0x0	DMA2_HLAF_IRQ_EN DMA 2 Half Package Transfer Interrupt Enable. 0: Disable, 1: Enable.
7	/	/	/
6	R/W	0x0	DMA1_QUEUE_IRQ_EN DMA 1 Queue End Transfer Interrupt Enable. 0: Disable, 1: Enable.
5	R/W	0x0	DMA1_PKG_IRQ_EN

			DMA 1 Package End Transfer Interrupt Enable. 0: Disable, 1: Enable.
4	R/W	0x0	DMA1_HLAF_IRQ_EN DMA 1 Half Package Transfer Interrupt Enable. 0: Disable, 1: Enable.
3	/	/	/
2	R/W	0x0	DMA0_QUEUE_IRQ_EN DMA 0 Queue End Transfer Interrupt Enable. 0: Disable, 1: Enable.
1	R/W	0x0	DMA0_PKG_IRQ_EN DMA 0 Package End Transfer Interrupt Enable. 0: Disable, 1: Enable.
0	R/W	0x0	DMA0_HLAF_IRQ_EN DMA 0 Half Package Transfer Interrupt Enable. 0: Disable, 1: Enable

3.11.4.2. DMA IRQ Pending Status Register0 (Default Value: 0x00000000)

Offset:0x10			Register Name: DMA_IRQ_PEND_REG0
Bit	R/W	Default/Hex	Description
31	/	/	/
30	R/W	0x0	DMA7_QUEUE_IRQ_PEND. DMA 7 Queue End Transfer Interrupt Pending. Set 1 to the bit will clear it. 0: No effect, 1: Pending.
29	R/W	0x0	DMA7_PKG_IRQ_PEND DMA 7 Package End Transfer Interrupt Pending. Set 1 to the bit will clear it. 0: No effect, 1: Pending.
28	R/W	0x0	DMA7_HLAF_IRQ_PEND. DMA 7 Half Package Transfer Interrupt Pending. Set 1 to the bit will clear it. 0: No effect, 1: Pending.
27	/	/	/
26	R/W	0x0	DMA6_QUEUE_IRQ_PEND. DMA 6 Queue End Transfer Interrupt Pending. Set 1 to the bit will clear it. 0: No effect, 1: Pending.
25	R/W	0x0	DMA6_PKG_IRQ_PEND DMA 6 Package End Transfer Interrupt Pending. Set 1 to the bit will clear it. 0: No effect, 1: Pending.

24	R/W	0x0	DMA6_HLAF_IRQ_PEND. DMA 6 Half Package Transfer Interrupt Pending. Set 1 to the bit will clear it. 0: No effect, 1: Pending.
23	/	/	/
22	R/W	0x0	DMA5_QUEUE_IRQ_PEND. DMA 5 Queue End Transfer Interrupt Pending. Set 1 to the bit will clear it. 0: No effect, 1: Pending.
21	R/W	0x0	DMA5_PKG_IRQ_PEND DMA 5 Package End Transfer Interrupt Pending. Set 1 to the bit will clear it. 0: No effect, 1: Pending.
20	R/W	0x0	DMA5_HLAF_IRQ_PEND. DMA 5 Half Package Transfer Interrupt Pending. Set 1 to the bit will clear it. 0: No effect, 1: Pending.
19	/	/	/
18	R/W	0x0	DMA4_QUEUE_IRQ_PEND. DMA 4 Queue End Transfer Interrupt Pending. Set 1 to the bit will clear it. 0: No effect, 1: Pending.
17	R/W	0x0	DMA4_PKG_IRQ_PEND DMA 4 Package End Transfer Interrupt Pending. Set 1 to the bit will clear it. 0: No effect, 1: Pending.
16	R/W	0x0	DMA4_HLAF_IRQ_PEND. DMA 4 Half Package Transfer Interrupt Pending. Set 1 to the bit will clear it. 0: No effect, 1: Pending.
15	/	/	/
14	R/W	0x0	DMA3_QUEUE_IRQ_PEND. DMA 3 Queue End Transfer Interrupt Pending. Set 1 to the bit will clear it. 0: No effect, 1: Pending.
13	R/W	0x0	DMA3_PKG_IRQ_PEND DMA 3 Package End Transfer Interrupt Pending. Set 1 to the bit will clear it. 0: No effect, 1: Pending.
12	R/W	0x0	DMA3_HLAF_IRQ_PEND. DMA 3 Half Package Transfer Interrupt Pending. Set 1 to the bit will clear it. 0: No effect, 1: Pending.
11	/	/	/

10	R/W	0x0	DMA2_QUEUE_IRQ_PEND. DMA 2 Queue End Transfer Interrupt Pending. Set 1 to the bit will clear it. 0: No effect, 1: Pending.
9	R/W	0x0	DMA2_PKG_IRQ_PEND DMA 2 Package End Transfer Interrupt Pending. Set 1 to the bit will clear it. 0: No effect, 1: Pending.
8	R/W	0x0	DMA2_HLAF_IRQ_PEND. DMA 2 Half Package Transfer Interrupt Pending. Set 1 to the bit will clear it. 0: No effect, 1: Pending.
7	/	/	/
6	R/W	0x0	DMA1_QUEUE_IRQ_PEND. DMA 1 Queue End Transfer Interrupt Pending. Set 1 to the bit will clear it. 0: No effect, 1: Pending.
5	R/W	0x0	DMA1_PKG_IRQ_PEND DMA 1 Package End Transfer Interrupt Pending. Set 1 to the bit will clear it. 0: No effect, 1: Pending.
4	R/W	0x0	DMA1_HLAF_IRQ_PEND. DMA 1 Half Package Transfer Interrupt Pending. Set 1 to the bit will clear it. 0: No effect, 1: Pending.
3	/	/	/
2	R/W	0x0	DMA0_QUEUE_IRQ_PEND. DMA 0 Queue End Transfer Interrupt Pending. Set 1 to the bit will clear it. 0: No effect, 1: Pending.
1	R/W	0x0	DMA0_PKG_IRQ_PEND DMA 0 Package End Transfer Interrupt Pending. Set 1 to the bit will clear it. 0: No effect, 1: Pending.
0	R/W	0x0	DMA0_HLAF_IRQ_PEND. DMA 0 Half Package Transfer Interrupt Pending. Set 1 to the bit will clear it. 0: No effect, 1: Pending.

3.11.4.3. DMA Security Register (Default Value: 0x00000000)

Offset:0x20			Register Name: DMA_SECURE_REG
Bit	R/W	Default/Hex	Description

31:8	/	/	/
7	R/W	0x0	DMA7_SEC DMA channel 7 security. 0: Secure, 1: Non-secure.
6	R/W	0x0	DMA6_SEC DMA channel 6 security. 0: Secure, 1: Non-secure.
5	R/W	0x0	DMA5_SEC DMA channel 5 security. 0: Secure, 1: Non-secure.
4	R/W	0x0	DMA4_SECURE. Indicating DMA 4 security. 0: Secure, 1: Non-secure.
3	R/W	0x0	DMA3_SECURE. Indicating DMA 3 security. 0: Secure, 1: Non-secure.
2	R/W	0x0	DMA2_SECURE. Indicating DMA 2 security. 0: Secure, 1: Non-secure.
1	R/W	0x0	DMA1_SECURE. Indicating DMA 1 security. 0: Secure, 1: Non-secure.
0	R/W	0x0	DMA0_SECURE. Indicating DMA 0 security. 0: Secure, 1: Non-secure.

3.11.4.4. DMA Auto Gating Register (Default Value: 0x00000000)

Offset:0x28			Register Name: DMA_AUTO_GATE_REG
Bit	R/W	Default/Hex	Description
31:3	/	/	/
2	R/W	0x0	DMA_MCLK_CIRCUIT. DMA MCLK interface circuit auto gating bit. 0: Auto gating enable 1: Auto gating disable.

1	R/W	0x0	DMA_COMMON_CIRCUIT. DMA common circuit auto gating bit. 0: Auto gating enable 1: Auto gating disable.
0	R/W	0x0	DMA_CHAN_CIRCUIT. DMA channel circuit auto gating bit. 0: Auto gating enable 1: Auto gating disable.

3.11.4.5. DMA Status Register (Default Value: 0x00000000)

Offset:0x30			Register Name: DMA_STA_REG
Bit	R/W	Default/Hex	Description
31	/	/	/
30	RO	0x0	MBUS FIFO Status 0:Empty 1:Not Empty
29:8	/	/	/
7	RO	0x0	DMA7_STATUS DMA Channel 7 Status. 0: Idle 1: Busy
6	RO	0x0	DMA6_STATUS DMA Channel 6 Status. 0: Idle 1: Busy
5	RO	0x0	DMA5_STATUS DMA Channel 5 Status. 0: Idle 1: Busy
4	RO	0x0	DMA4_STATUS DMA Channel 4 Status. 0: Idle 1: Busy.
3	RO	0x0	DMA3_STATUS DMA Channel 3 Status. 0: Idle 1: Busy.
2	RO	0x0	DMA2_STATUS DMA Channel 2 Status. 0: Idle, 1: Busy.
1	RO	0x0	DMA1_STATUS

			DMA Channel 1 Status. 0: Idle, 1: Busy.
0	RO	0x0	DMA0_STATUS DMA Channel 0 Status. 0: Idle, 1: Busy.

3.11.4.6. DMA Channel Enable Register (Default Value: 0x00000000)

Offset: 0x100+N*0x40+0x0(N=0~7)			Register Name: DMA_EN_REG
Bit	R/W	Default/Hex	Description
31:1	/	/	/
0	R/W	0x0	DMA_EN. DMA Channel Enable 0: Disable 1: Enable.

3.11.4.7. DMA Channel Pause Register (Default Value: 0x00000000)

Offset: 0x100+N*0x40+0x4(N=0~7)			Register Name: DMA_PAU_REG
Bit	R/W	Default/Hex	Description
31:1	/	/	/
0	R/W	0x0	DMA_PAUSE. Pausing DMA Channel Transfer Data. 0: Resume Transferring, 1: Pause Transferring.

3.11.4.8. DMA Channel Descriptor Address Register (Default Value: 0x00000000)

Offset: 0x100+N*0x40+0x8(N=0~7)			Register Name: DMA_DESC_ADDR_REG
Bit	R/W	Default/Hex	Description
31:1	R/W	0x0	DMA_DESC_ADDR DMA Channel Descriptor Address. The Descriptor Address must be half-word aligned before DMA enable.
0	R/W	0x0	DMA_DESCPT_ADDR_HIGH. This bit would be used to storing [32] bits of the descriptor address, if it is necessary. Otherwise, it should be 0.

Note:After DMA channel completed all data transmission,the final value of the register is 0xFFFFF800.

3.11.4.9. DMA Channel Configuration Register (Default Value: 0x00000000)

Offset: 0x100+N*0x40+0xC(N=0~7)			Register Name: DMA_CFG_REG
Bit	R/W	Default/Hex	Description
31:27	/	/	/
26:25	RO	0x0	DMA_DEST_DATA_WIDTH. DMA Destination Data Width. 00: 8-bit 01: 16-bit 10: 32-bit 11: 64-bit
24	/	/	/
23:22	RO	0x0	DMA_DEST_BLOCK_SIZE. DMA Destination Block Size. 00: 1 01: 4 10: 8 11: 16
21	RO	0x0	DMA_ADDR_MODE. DMA Destination Address Mode 0: Linear Mode 1: IO Mode
20:16	RO	0x0	DMA_DEST_DRQ_TYPE. DMA Destination DRQ Type The details in DRQ Type and Port Corresponding Relation.
15:11	/	/	/
10:9	RO	0x0	DMA_SRC_DATA_WIDTH. DMA Source Data Width. 00: 8-bit 01: 16-bit 10: 32-bit 11: 64-bit
8	/	/	/
7:6	RO	0x0	DMA_SRC_BLOCK_SIZE. DMA Source Block Size. 00: 1 01: 4 10: 8 11: 16
5	RO	0x0	DMA_SRC_ADDR_MODE. DMA Source Address Mode 0: Linear Mode

			1: IO Mode
4:0	RO	0x0	DMA_SRC_DRQ_TYPE. DMA Source DRQ Type The details in DRQ Type and Port Corresponding Relation.

3.11.4.10. DMA Channel Current Source Address Register (Default Value: 0x00000000)

Offset: 0x100+N*0x40+0x10(N=0~7)		Register Name: DMA_CUR_SRC_REG	
Bit	R/W	Default/Hex	Description
31:0	RO	0x0	DMA_CUR_SRC. DMA Channel Current Source Address, read only.

3.11.4.11. DMA Channel Current Destination Address Register (Default Value: 0x00000000)

Offset: 0x100+N*0x40+0x14(N=0~7)		Register Name: DMA_CUR_DEST_REG	
Bit	R/W	Default/Hex	Description
31:0	RO	0x0	DMA_CUR_DEST. DMA Channel Current Destination Address, read only.

3.11.4.12. DMA Channel Byte Counter Left Register (Default Value: 0x00000000)

Offset: 0x100+N*0x40+0x18(N=0~7)		Register Name: DMA_BCNT_LEFT_REG	
Bit	R/W	Default/Hex	Description
31:25	/	/	/
24:0	RO	0x0	DMA_BCNT_LEFT. DMA Channel Byte Counter Left, read only.

3.11.4.13. DMA Channel Parameter Register (Default Value: 0x00000000)

Offset: 0x100+N*0x40+0x1C(N=0~7)		Register Name: DMA_PARA_REG	
Bit	R/W	Default/Hex	Description
31:19	/	/	/
18	RO	0x0	DMA_DST_HBIT_ADDR.
17	/	/	/
16	RO	0x0	DMA_SRC_HBIT_ADDR.
15:8	/	/	/
7:0	RO	0x0	WAIT_CLK_CYCLE. Wait clock cycle.

3.11.4.14. DMA Mode Register (Default Value: 0x00000000)

Offset: 0x100+N*0x40+0x28(N=0~7)			Register Name: DMA_MODE_REG
Bit	R/W	Default/Hex	Description
31:4	/	/	/
3	R/W	0x0	DMA_DST_MODE. 0: Wait mode. 1: Handshake mode.
2	R/W	0x0	DMA_SRC_MODE. 0: Wait mode. 1: Handshake mode.
1:0	/	/	/

3.11.4.15. DMA Former Descriptor Address Register (Default Value: 0x00000000)

Offset: 0x100+N*0x40+0x2C(N=0~7)			Register Name: DMA_FDESC_ADDR_REG
Bit	R/W	Default/Hex	Description
31:0	RO	0x0	DMA_FDESC_ADDR. This register is used to storing the former value of DMA Channel Descriptor Address Register .

3.11.4.16. DMA Package Number Register (Default Value: 0x00000000)

Offset: 0x100+N*0x40+0x30(N=0~7)			Register Name: DMA_PKG_NUM_REG
Bit	R/W	Default/Hex	Description
31:0	RO	0x0	DMA_PKG_NUM. This register will record the number of packages which has been completed in one transmission.

3.12. GIC

For details about GIC, please refer to the *GIC PL400 technical reference manual* and *ARM GIC Architecture Specification V2.0*.

3.12.1. Interrupt Source

Interrupt Source	SRC	Vector	Description
SGI 0	0	0x0000	SGI 0 interrupt
SGI 1	1	0x0004	SGI 1 interrupt
SGI 2	2	0x0008	SGI 2 interrupt
SGI 3	3	0x000C	SGI 3 interrupt
SGI 4	4	0x0010	SGI 4 interrupt
SGI 5	5	0x0014	SGI 5 interrupt
SGI 6	6	0x0018	SGI 6 interrupt
SGI 7	7	0x001C	SGI 7 interrupt
SGI 8	8	0x0020	SGI 8 interrupt
SGI 9	9	0x0024	SGI 9 interrupt
SGI 10	10	0x0028	SGI 10 interrupt
SGI 11	11	0x002C	SGI 11 interrupt
SGI 12	12	0x0030	SGI 12 interrupt
SGI 13	13	0x0034	SGI 13 interrupt
SGI 14	14	0x0038	SGI 14 interrupt
SGI 15	15	0x003C	SGI 15 interrupt
PPI 0	16	0x0040	PPI 0 interrupt
PPI 1	17	0x0044	PPI 1 interrupt
PPI 2	18	0x0048	PPI 2 interrupt
PPI 3	19	0x004C	PPI 3 interrupt
PPI 4	20	0x0050	PPI 4 interrupt
PPI 5	21	0x0054	PPI 5 interrupt
PPI 6	22	0x0058	PPI 6 interrupt
PPI 7	23	0x005C	PPI 7 interrupt
PPI 8	24	0x0060	PPI 8 interrupt
PPI 9	25	0x0064	PPI 9 interrupt
PPI 10	26	0x0068	PPI 10 interrupt
PPI 11	27	0x006C	PPI 11 interrupt
PPI 12	28	0x0070	PPI 12 interrupt
PPI 13	29	0x0074	PPI 13 interrupt
PPI 14	30	0x0078	PPI 14 interrupt
PPI 15	31	0x007C	PPI 15 interrupt

UART 0	32	0x0080	UART 0 interrupt
UART 1	33	0x0084	UART 1 interrupt
UART 2	34	0x0088	UART 2 interrupt
UART 3	35	0x008C	UART 3 interrupt
UART 4	36	0x0090	UART 4 interrupt
	37	0x0094	
TWI 0	38	0x0098	TWI 0 interrupt
TWI 1	39	0x009C	TWI 1 interrupt
TWI 2	40	0x00A0	TWI 2 interrupt
	41	0x00A4	
	42	0x00A8	
PB_EINT	43	0x00AC	PB_EINT interrupt
OWA	44	0x00B0	OWA interrupt
I2S/PCM-0	45	0x00B4	I2S/PCM-0 interrupt
I2S/PCM-1	46	0x00B8	I2S/PCM-1 interrupt
I2S/PCM-2	47	0x00BC	I2S/PCM-2 interrupt
	48	0x00C0	
PG_EINT	49	0x00C4	PG_EINT interrupt
Timer 0	50	0x00C8	Timer 0 interrupt
Timer 1	51	0x00CC	Timer 1 interrupt
	52	0x00D0	
PH_EINT	53	0x00D4	PH_EINT interrupt
	54	0x00D8	
	55	0x00DC	
	56	0x00E0	
Watchdog	57	0x00E4	Watchdog interrupt
	58	0x00E8	
	59	0x00EC	
AC_DET	60	0x00F0	Audio Codec earphone detect interrupt
Audio Codec	61	0x00F4	Audio Codec interrupt
KEYADC	62	0x00F8	KEYADC interrupt
Thermal Sensor	63	0x00FC	Thermal Sensor interrupt
External NMI	64	0x100	External Non-Mask Interrupt
R_timer 0	65	0x104	R_timer 0 interrupt
R_timer 1	66	0x108	R_timer 1 interrupt
	67	0x010C	
R_watchdog	68	0x0110	R_watchdog interrupt
R_CIR_RX	69	0x00E8	R_CIR_RX interrupt
R_UART	70	0x0118	R_UART interrupt
R_RSB	71	0x011C	R_RSB interrupt
R_Alarm 0	72	0x0120	R_Alarm 0 interrupt
R_Alarm 1	73	0x0124	R_Alarm 1 interrupt
R_timer 2	74	0x0128	R_timer 2 interrupt

R_timer 3	75	0x012C	R_timer 3 interrupt
R_TWI	76	0x0130	R_TWI interrupt
R_PL_EINT	77	0x0134	R_PL_EINT interrupt
R_TWD	78	0x0138	R_TWD interrupt
	79	0x013C	
	80	0x0140	
MSGBOX	81	0x0144	MSGBOX interrupt
DMA	82	0x0148	DMA channel interrupt
HS Timer	83	0x014C	HS Timer interrupt
	84	0x0150	
	85	0x0154	
	86	0x0158	
	87	0x015C	
SMC	88	0x0160	SMC interrupt
	89	0x0164	
VE	90	0x0168	VE interrupt
	91	0x016C	
SD/MMC 0	92	0x0170	SD/MMC Host Controller 0 interrupt
SD/MMC 1	93	0x0174	SD/MMC Host Controller 1 interrupt
SD/MMC 2	94	0x0178	SD/MMC Host Controller 2 interrupt
	95	0x017C	
	96	0x0180	
SPI 0	97	0x0184	SPI 0 interrupt
SPI 1	98	0x0188	SPI 1 interrupt
	99	0x018C	
	100	0x0190	
DRAM_MDFS	101	0x0194	DRAM MDFS interrupt
NAND	102	0x0198	NAND Flash Controller interrupt
USB-OTG	103	0x019C	USB-OTG interrupt
USB-OTG-EHCI	104	0x01A0	USB-OTG-EHCI interrupt
USB-OTG-OHCI	105	0x01A4	USB-OTG-OHCI interrupt
USB-EHCI0	106	0x01A8	USB-EHCI0 interrupt
USB-OHCI0	107	0x01AC	USB-OHCI0 interrupt
	108	0x01B0	
	109	0x01B4	
	110	0x01B8	
	111	0x01BC	
CE0	112	0x01C0	CE interrupt
TS	113	0x01C4	TS interrupt
EMAC	114	0x01C8	EMAC interrupt
SCR	115	0x01CC	SCR interrupt
CSI	116	0x01D0	CSI interrupt
CSI_CCI	117	0x01D4	CSI_CCI interrupt

TCON0	118	0x01D8	TCON0 interrupt
TCON1	119	0x01DC	TCON1 interrupt
HDMI	120	0x01E0	HDMI interrupt
MIPI DSI	121	0x01E4	MIPI DSI interrupt
	122	0x01E8	
	123	0x01EC	
	124	0x01F0	
DIT	125	0x01F4	De-interlace interrupt
CE1	126	0x01F8	CE1 interrupt
DE	127	0x01FC	DE interrupt
ROT	128	0x0200	DE_RORATE interrupt
GPU-GP	129	0x0204	GPU-GP interrupt
GPU-GPMMU	130	0x0208	GPU-GPMMU interrupt
GPU-PP0	131	0x020C	GPU-PP0 interrupt
GPU-PP0MMU	132	0x0210	GPU-PPMMU0 interrupt
GPU-PMU	133	0x0214	GPU-PMU interrupt
GPU-PP1	134	0x0218	GPU-PP1 interrupt
GPU-PPMMU1	135	0x021C	GPU-PPMMU1 interrupt
	136	0x0220	
	137	0x0224	
	138	0x0228	
	139	0x022C	
CTI0	140	0x0230	CTI0 interrupt
CTI1	141	0x0234	CTI1 interrupt
CTI2	142	0x0238	CTI2 interrupt
CTI3	143	0x023C	CTI3 interrupt
COMMTX0	144	0x0240	COMMTX0 interrupt
COMMTX1	145	0x0244	COMMTX1 interrupt
COMMTX2	146	0x0248	COMMTX2 interrupt
COMMTX3	147	0x024C	COMMTX3 interrupt
COMMRX0	148	0x0250	COMMRX0 interrupt
COMMRX1	149	0x0254	COMMRX1 interrupt
COMMRX2	150	0x0258	COMMRX2 interrupt
COMMRX3	151	0x025C	COMMRX3 interrupt
PMU0	152	0x0260	PMU0 interrupt
PMU1	153	0x0264	PMU1 interrupt
PMU2	154	0x0268	PMU2 interrupt
PMU3	155	0x026C	PMU3 interrupt
AXI_ERROR	156	0x0270	AXI_ERROR interrupt

3.13. Message Box

3.13.1. Overview

Message Box provides an MSGBox-interrupt mechanism for on-chip processors intercommunication. It allows a processor transmit messages to the other one or receive messages from the other through a series of Message Queues, each of which is a four 32-bits depth FIFO. An intercommunication channel could be established by configuring Message Box registers and it works under MSGBox-interrupt mechanism.

The Message Box includes the following features:

- Two users for Message Box instance (User0 for CPUS and User1 for CPUX)
- Eight Message Queues for the MSGBox instance
- Each of Queues has four 32-bits depth FIFO for establishing intercommunication channel
- Each of Queues could be configured as transmitter or receiver for user
- Message reception and queue-not-full notification interrupt mechanism

3.13.2. Functionalities Description

3.13.2.1. Typical Applications

Typical Application Flow Chart

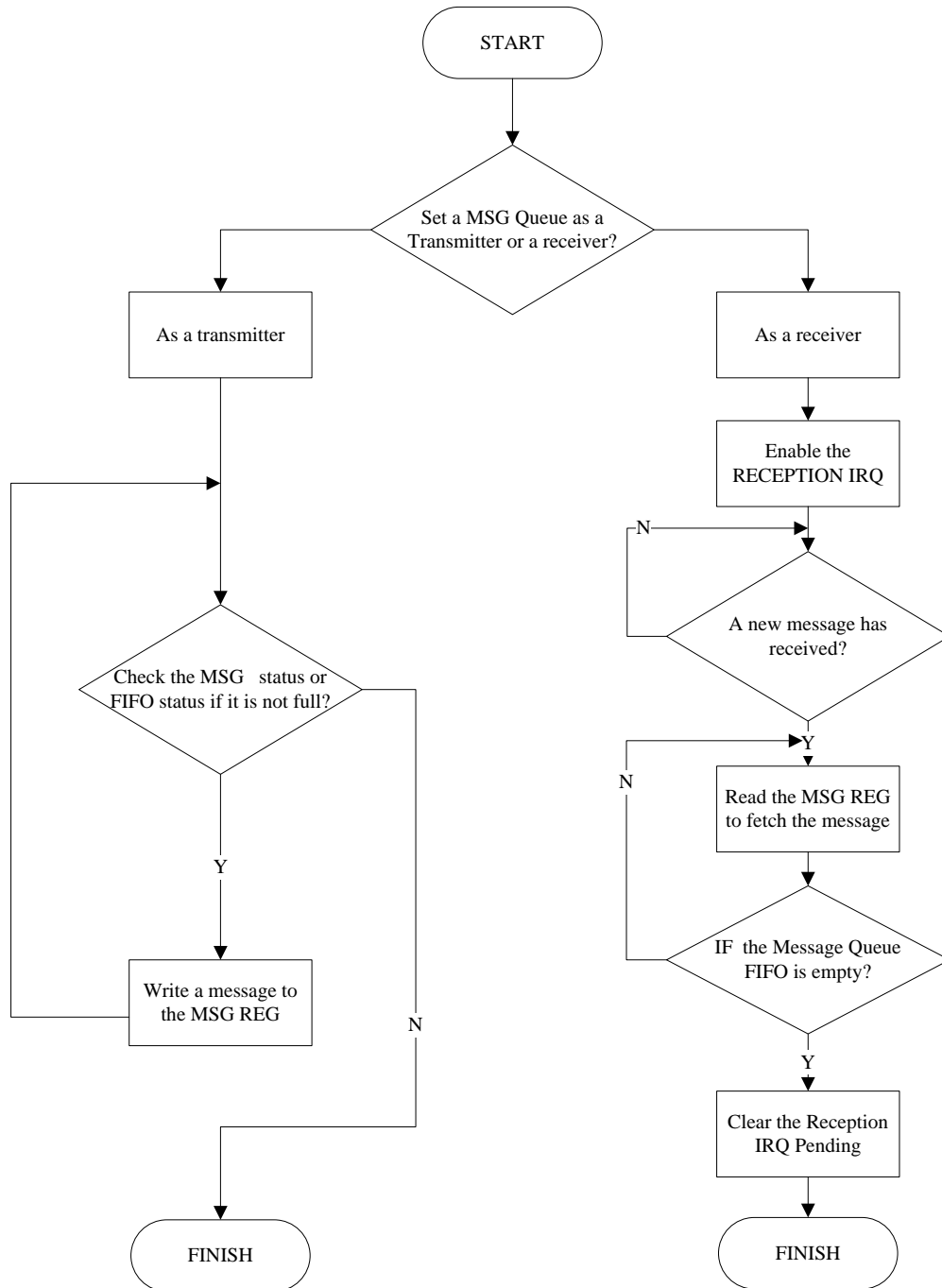

Figure 3-10. Message Box Typical Application Chart

3.13.2.2. Functional Block Diagram

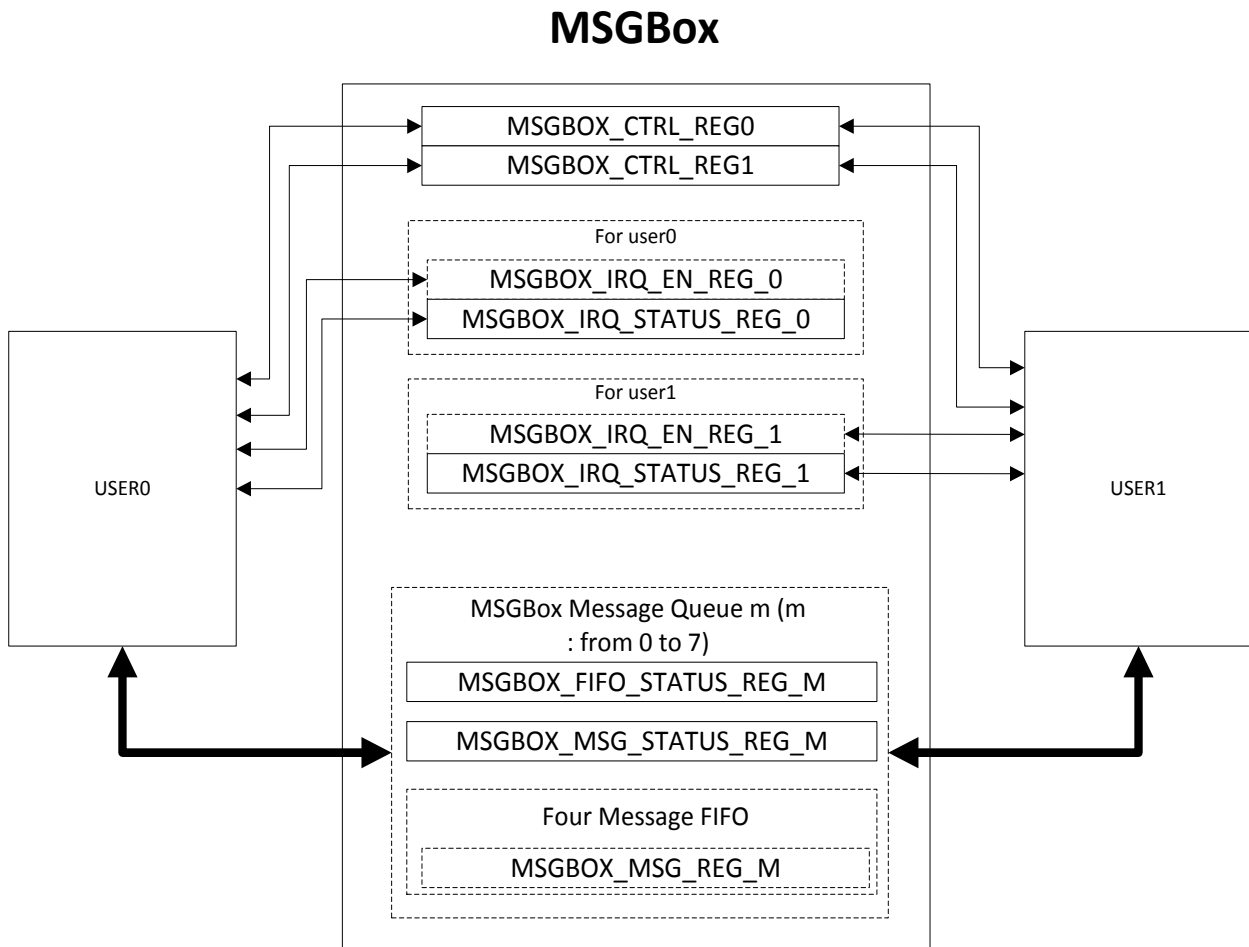

Figure 3-11. Message Box Functional Block Diagram

Message Box supports a set of registers for a processor to establish an interconnection channel with the others. The processor determines message queue numbers for interconnection and the used queues to the transmitter or receiver for itself and the interconnectible one. Every queue has a **MSGBox FIFO Status Register** for processor to check out queue FIFO full status and a **MSGBox Message Status Register** for processor to check out message numbers in queue FIFO. Otherwise, every queue has a corresponding IRQ status bit and a corresponding IRQ enable bit, which used for requesting interrupt.

3.13.3. Operation Principle

3.13.3.1. Message Queue Assignment

To transmit messages from a user to the other user through any Message Queue, set the corresponding bit in the **MSGBox Control Register 0** or **MSGBox Control Register 1** register.

When a 32-bit message is written to the MSGBOX_MSG_REG_M register, the message is appended into the FIFO queue. This queue holds 4 messages. If the queue is full, the message is discarded. The receiver user could read the **MSGBox Message Queue Register** (m is the message queue number, where m=0 to 7) to retrieve a message from the corresponding Message Queue FIFO.

It is recommended that register polling be used for a user to send a message:

- Set a Message Queue as a transmitter (in the **MSGBox Control Register 0 /MSGBox Control Register 1**).
- Check the FIFO status or the message status (in the **MSGBox FIFO Status Register m** or **MSGBox Message Status Register m**).
- Write the message to the corresponding **MSGBox Message Queue Register**, if space is available.

The transmit interrupt might be used when the initial MSGBox status indicates that the Message Queue is full. In this case, the sender can enable the corresponding **MSGBox IRQ Enable Register u** interrupt for the user. This allows the user to be notified by interrupt when the message queue is not full.

3.13.3.2. Interrupt request

An interrupt request allows the user of the MSGBox to be notified when a new message is received or when the message queue is not full.

An event can generate an interrupt request when enable the corresponding bit in the **MSGBox IRQ Enable Register u** (u is the user number, where u=0 or 1) register. Events are reported in the appropriate **MSGBox IRQ Status Register u** register.

An event stops generating interrupt requests when disable the corresponding bit in the **MSGBox IRQ Enable Register u** register.

In case of the **MSGBox IRQ Status Register u**, the event is reported in the corresponding bit even if the interrupt request generation is disabled for this event.

3.13.4. Message Box Register List

Module Name	Base Address
MSGBOX	0x01C17000

Register Name	Offset	Description
MSGBOX_CTRL_REG0	0x0000	Message Queue Attribute Control Register 0
MSGBOX_CTRL_REG1	0x0004	Message Queue Attribute Control Register 1
MSGBOXU_IRQ_EN_REG	0x0040+N*0x20	IRQ Enable For User N(N=0,1)
MSGBOXU_IRQ_STATUS_REG	0x0050+N*0x20	IRQ Status For User N(N=0,1)

MSGBOXM_FIFO_STATUS_REG	0x0100+N*0x4	FIFO Status For Message Queue N(N = 0~7)
MSGBOXM_MSG_STATUS_REG	0x0140+N*0x4	Message Status For Message Queue N(N=0~7)
MSGBOXM_MSG_REG	0x0180+N*0x4	Message Register For Message Queue N(N=0~7)

3.13.5. Message Box Register Description

3.13.5.1. MSGBox Control Register 0(Default Value: 0x10101010)

Offset: 0x00			Register Name: MSGBOX_CTRL_REG0
Bit	R/W	Default/Hex	Description
31:29	/	/	/
28	R/W	0x1	TRANSMIT_MQ3. Message Queue 3 is a Transmitter of user u. 0: user0 1: user1
27:25	/	/	/
24	R/W	0x0	RECEPTION_MQ3. Message Queue 3 is a Receiver of user u. 0: user0 1: user1
23:21	/	/	/
20	R/W	0x1	TRANSMIT_MQ2. Message Queue 2 is a Transmitter of user u. 0: user0 1: user1
19:17	/	/	/
16	R/W	0x0	RECEPTION_MQ2. Message Queue 2 is a Receiver of user u. 0: user0 1: user1
15:13	/	/	/
12	R/W	0x1	TRANSMIT_MQ1 Message Queue 1 is a Transmitter of user u. 0: user0 1: user1
11:9	/	/	/
8	R/W	0x0	RECEPTION_MQ1. Message Queue 1 is a Receiver of user u. 0: user0 1: user1
7:5	/	/	/

4	R/W	0x1	TRANSMIT_MQ0. Message Queue 0 is a Transmitter of user u. 0: user0 1: user1
3:1	/	/	/
0	R/W	0x0	RECEPTION_MQ0. Message Queue 0 is a Receiver of user u. 0: user0 1: user1

3.13.5.2. MSGBox Control Register 1(Default Value: 0x10101010)

Offset: 0x04			Register Name: MSGBOX_CTRL_REG1
Bit	R/W	Default/Hex	Description
31:29	/	/	/
28	R/W	0x1	TRANSMIT_MQ7. Message Queue 7 is a Transmitter of user u. 0: user0 1: user1
27:25	/	/	/
24	R/W	0x0	RECEPTION_MQ7. Message Queue 7 is a Receiver of user u. 0: user0 1: user1
23:21	/	/	/
20	R/W	0x1	TRANSMIT_MQ6. Message Queue 6 is a Transmitter of user u. 0: user0 1: user1
19:17	/	/	/
16	R/W	0x0	RECEPTION_MQ6. Message Queue 6 is a Receiver of user u. 0: user0 1: user1
15:13	/	/	/
12	R/W	0x1	TRANSMIT_MQ5 Message Queue 5 is a Transmitter of user u. 0: user0 1: user1
11:9	/	/	/
8	R/W	0x0	RECEPTION_MQ5. Message Queue 5 is a Receiver of user u.

			0: user0 1: user1
7:5	/	/	/
4	R/W	0x1	TRANSMIT_MQ4. Message Queue 4 is a Transmitter of user u. 0: user0 1: user1
3:1	/	/	/
0	R/W	0x0	RECEPTION_MQ4. Message Queue 4 is a Receiver of user u. 0: user0 1: user1

3.13.5.3. MSGBox IRQ Enable Register u(Default Value: 0x00000000)

Offset:0x40+N*0x20 (N=0,1)			Register Name: MSGBOXU_IRQ_EN_REG
Bit	R/W	Default/Hex	Description
31:16	/	/	/
15	R/W	0x0	TRANSMIT_MQ7_IRQ_EN. 0: Disable 1: Enable (It will notify user u by interrupt when Message Queue 7 is not full.)
14	R/W	0x0	RECEPTION_MQ7_IRQ_EN. 0: Disable 1: Enable (It will notify user u by interrupt when Message Queue 7 has received a new message.)
13	R/W	0x0	TRANSMIT_MQ6_IRQ_EN. 0: Disable 1: Enable (It will Notify user u by interrupt when Message Queue 6 is not full.)
12	R/W	0x0	RECEPTION_MQ6_IRQ_EN. 0: Disable 1: Enable (It will notify user u by interrupt when Message Queue 6 has received a new message.)
11	R/W	0x0	TRANSMIT_MQ5_IRQ_EN. 0: Disable 1: Enable (It will notify user u by interrupt when Message Queue 5 is not full.)
10	R/W	0x0	RECEPTION_MQ5_IRQ_EN. 0: Disable 1: Enable (It will notify user u by interrupt when Message Queue 5 has received a new message.)

9	R/W	0x0	TRANSMIT_MQ4_IRQ_EN. 0: Disable 1: Enable (It will notify user u by interrupt when Message Queue 4 is not full.)
8	R/W	0x0	RECEPTION_MQ4_IRQ_EN. 0: Disable 1: Enable (It will notify user u by interrupt when Message Queue 4 has received a new message.)
7	R/W	0x0	TRANSMIT_MQ3_IRQ_EN. 0: Disable 1: Enable (It will notify user u by interrupt when Message Queue 3 is not full.)
6	R/W	0x0	RECEPTION_MQ3_IRQ_EN. 0: Disable 1: Enable (It will notify user u by interrupt when Message Queue 3 has received a new message.)
5	R/W	0x0	TRANSMIT_MQ2_IRQ_EN. 0: Disable 1: Enable (It will notify user u by interrupt when Message Queue 2 is not full.)
4	R/W	0x0	RECEPTION_MQ2_IRQ_EN. 0: Disable 1: Enable (It will notify user u by interrupt when Message Queue 2 has received a new message.)
3	R/W	0x0	TRANSMIT_MQ1_IRQ_EN. 0: Disable 1: Enable (It will notify user u by interrupt when Message Queue 1 is not full.)
2	R/W	0x0	RECEPTION_MQ1_IRQ_EN. 0: Disable 1: Enable (It will notify user u by interrupt when Message Queue 1 has received a new message.)
1	R/W	0x0	TRANSMIT_MQ0_IRQ_EN. 0: Disable 1: Enable (It will notify user u by interrupt when Message Queue 0 is not full.)
0	R/W	0x0	RECEPTION_MQ0_IRQ_EN. 0: Disable 1: Enable (It will notify user u by interrupt when Message Queue 0 has received a new message.)

3.13.5.4. MSGBox IRQ Status Register u(Default Value: 0x000AAAA)

Offset:0x50+N*0x20 (N=0,1)			Register Name: MSGBOXU_IRQ_STATUS_REG
Bit	R/W	Default/Hex	Description
31:16	/	/	/
15	R/W	0x1	TRANSMIT_MQ7_IRQ_PEND. 0: No effect, 1: Pending. This bit will be pending for user u when Message Queue 7 is not full. Set one to this bit will clear it.
14	R/W	0x0	RECEPTION_MQ7_IRQ_PEND. 0: No effect, 1: Pending. This bit will be pending for user u when Message Queue 7 has received a new message. Set one to this bit will clear it.
13	R/W	0x1	TRANSMIT_MQ6_IRQ_PEND. 0: No effect, 1: Pending. This bit will be pending for user u when Message Queue 6 is not full. Set one to this bit will clear it.
12	R/W	0x0	RECEPTION_MQ6_IRQ_PEND. 0: No effect, 1: Pending. This bit will be pending for user u when Message Queue 6 has received a new message. Set one to this bit will clear it.
11	R/W	0x1	TRANSMIT_MQ5_IRQ_PEND. 0: No effect, 1: Pending. This bit will be pending for user u when Message Queue 5 is not full. Set one to this bit will clear it.
10	R/W	0x0	RECEPTION_MQ5_IRQ_PEND. 0: No effect, 1: Pending. This bit will be pending for user u when Message Queue 5 has received a new message. Set one to this bit will clear it.
9	R/W	0x1	TRANSMIT_MQ4_IRQ_PEND. 0: No effect, 1: Pending. This bit will be pending for user u when Message Queue 4 is not full. Set one to this bit will clear it.
8	R/W	0x0	RECEPTION_MQ4_IRQ_PEND. 0: No effect, 1: Pending. This bit will be pending for user u when Message Queue 4 has received a new message. Set one to this bit will clear it.
7	R/W	0x1	TRANSMIT_MQ3_IRQ_PEND. 0: No effect, 1: Pending. This bit will be pending for user u when Message Queue 3 is not full. Set one to this bit will clear it.
6	R/W	0x0	RECEPTION_MQ3_IRQ_PEND. 0: No effect,

			1: Pending. This bit will be pending for user u when Message Queue 3 has received a new message. Set one to this bit will clear it.
5	R/W	0x1	TRANSMIT_MQ2_IRQ_PEND. 0: No effect, 1: Pending. This bit will be pending for user u when Message Queue 2 is not full. Set one to this bit will clear it.
4	R/W	0x0	RECEPTION_MQ2_IRQ_PEND. 0: No effect, 1: Pending. This bit will be pending for user u when Message Queue 2 has received a new message. Set one to this bit will clear it.
3	R/W	0x1	TRANSMIT_MQ1_IRQ_PEND. 0: No effect, 1: Pending. This bit will be pending for user u when Message Queue 1 is not full. Set one to this bit will clear it.
2	R/W	0x0	RECEPTION_MQ1_IRQ_PEND. 0: No effect, 1: Pending. This bit will be pending for user u when Message Queue 1 has received a new message. Set one to this bit will clear it.
1	R/W	0x1	TRANSMIT_MQ0_IRQ_PEND. 0: No effect, 1: Pending. This bit will be pending for user u when Message Queue 0 is not full. Set one to this bit will clear it.
0	R/W	0x0	RECEPTION_MQ0_IRQ_PEND. 0: No effect, 1: Pending. This bit will be pending for user u when Message Queue 0 has received a new message. Set one to this bit will clear it.

3.13.5.5. MSGBox FIFO Status Register m(Default Value: 0x00000000)

Offset:0x100+N*0x4 (N=0~7)			Register Name: MSGBOXM_FIFO_STATUS_REG
Bit	R/W	Default/Hex	Description
31: 1	/	/	/
0	RO	0x0	FIFO_FULL_FLAG. 0: The Message FIFO queue is not full (space is available), 1: The Message FIFO queue is full. This FIFO status register has the status related to the message queue.

3.13.5.6. MSGBox Message Status Register m(Default Value: 0x00000000)

Offset:0x140+N*0x4 (N=0~7)			Register Name: MSGBOXM_MSG_STATUS_REG
Bit	R/W	Default/Hex	Description

31:3	/	/	/
2:0	RO	0x0	<p>MSG_NUM.</p> <p>Number of unread messages in the message queue. Here, limited to four messages per message queue.</p> <p>000: There is no message in the message FIFO queue.</p> <p>001: There is 1 message in the message FIFO queue.</p> <p>010: There are 2 messages in the message FIFO queue.</p> <p>011: There are 3 messages in the message FIFO queue.</p> <p>100: There are 4 messages in the message FIFO queue.</p> <p>101~111:/</p>

3.13.5.7. MSGBox Message Queue Register (Default Value: 0x00000000)

Offset:0x180+N*0x4 (N=0~7)			Register Name: MSGBOXM_MSG_REG
Bit	R/W	Default/Hex	Description
31:0	R/W	0x0	The message register stores the next to be read message of the message FIFO queue. Reads remove the message from the FIFO queue.

3.14. Spinlock

3.14.1. Overview

Spinlock provides hardware assistance for synchronizing the processes running on multiple processors in the device. The SpinLock module implements thirty-two 32-bit spinlocks (or hardware semaphores), which provide an efficient way to perform a lock operation of a device resource using a single read access, thus avoiding the need for a 'read-modify-write' bus transfer that not all the programmable cores are capable of.

Spinlocks are present to solve the need for synchronization and mutual exclusion between heterogeneous processors and those not operating under a single, shared operating system. There is no alternative mechanism to accomplish these operations between processors in separate subsystems. However, Spinlocks do not solve all system synchronization issues. They have limited applicability and should be used with care to implement higher level synchronization protocols.

A spinlock is appropriate for mutual exclusion for access to a shared data structure. It should be used only when:

- 1) The time to hold the lock is predictable and small (for example, a maximum hold time of less than 200 CPU cycles may be acceptable).
- 2) The locking task cannot be preempted, suspended, or interrupted while holding the lock (this would make the hold time large and unpredictable).
- 3) The lock is lightly contended, that is the chance of any other process (or processor) trying to acquire the lock while it is held is small.

If the conditions are not met, then a spinlock is not a good candidate. One alternative is to use a spinlock for critical section control (engineered to meet the conditions) to implement a higher level semaphore that can support preemption, notification, timeout or other higher level properties.

The Spinlock includes the following features:

- Spinlock module includes 32 spinlocks
- Two kinds of status of lock register: TAKEN and NOT TAKEN

3.14.2. Functionalities Description

3.14.2.1. Typical Applications

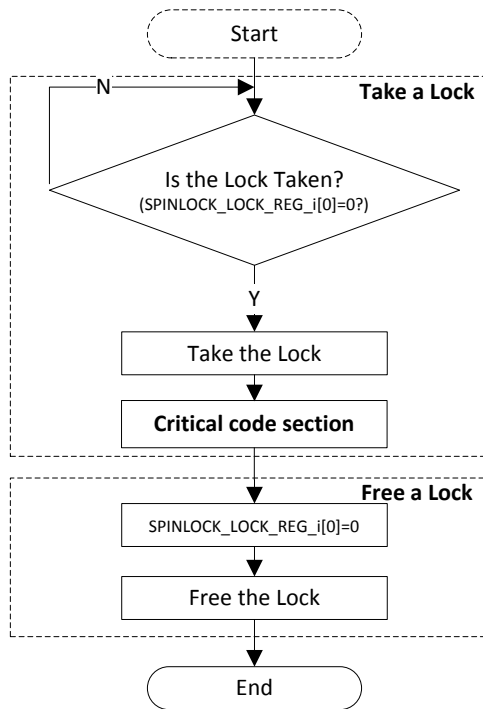

Figure3-11. Spinlock Typical Application Flow Chart

3.14.2.2. Functional Block Diagram

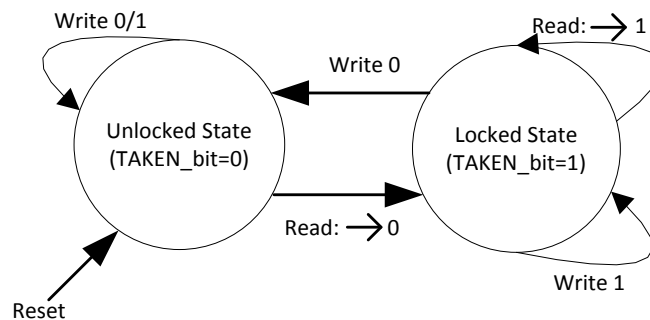

Figure 3-12. Spinlock Lock Register State Diagram

Every lock register has two kinds of states: TAKEN(locked) or NOT TAKEN(Unlocked). Only read-0-access and write-0-access could change lock register' state and the other accesses has no effect. Just 32-bit reads and

writes are supported to access all lock registers.

3.14.3. Operation Principle

3.14.3.1. Spinlock clock gating and software reset

Spinlock clock gating should be open before using it. Setting the bit[22] of **Bus Clock Gating Register1** to 1 could activate Spinlock and then de-asserting it's software reset. Setting the bit[22] of **Bus Software Reset Register 1** to 1 could de-assert the software reset of Spinlock. If it is no need to use spinlock, both the gating bit and software reset bit should be set 0.

3.14.3.2. Take and free a spinlock

Checking out **Spinlock Register Status** is necessary when a processor would like to take a spinlock. This register stores all 32 lock registers' status: TAKEN or NOT TAKEN(free).

In order to request to take a spinlock, a processor has to do a read-access to the corresponding lock register. If lock register returns 0, the processor takes this spinlock. And if lock register returns 1, the processor must retry.

Writing 0 to a lock register frees the corresponding spinlock. If the lock register is not taken, write-access has no effect. For a taken spinlock, every processor has the privilege to free this spinlock. But it is suggested that the processor which has taken the spinlock free it for strictness.

3.14.4. Spinlock Register List

Module Name	Base Address
SPINLOCK	0x01C18000

Register Name	Offset	Description
SPINLOCK_SYSTATUS_REG	0x0000	Spinlock System Status Register
SPINLOCK_STATUS_REG	0x0010	Spinlock Status Register
SPINLOCK_LOCK_REGN	0x100+N*0x4	Spinlock Lock Register N (N=0~31)

3.14.5. Spinlock Register Description

3.14.5.1. Spinlock System Status Register (Default Value: 0x10000000)

Offset: 0x0			Register Name: SPINLOCK_SYSTATUS_REG
Bit	R/W	Default/Hex	Description
31:30	/	/	/
29:28	RO	0x1	LOCKS_NUM. Number of lock registers implemented. 0x1: This instance has 32 lock registers. 0x2: This instance has 64 lock registers. 0x3: This instance has 128 lock registers. 0x4: This instance has 256 lock registers.
27:16	/	/	/
15:9	/	/	/
8	RO	0x0	IU0. In-Use flag0, covering lock register0-31. 0: All lock register 0-31 are in the Not Taken state. 1: At least one of the lock register 0-31 is in the Taken state.
7:0	/	/	/

3.14.5.2. Spinlock Register Status (Default Value: 0x00000000)

Offset: 0x10			Register Name: SPINLOCK_STATUS_REG
Bit	R/W	Default/Hex	Description
[i] (i=0~31)	RO	0x0	LOCK_REG_STATUS. SpinLock[i] status (i=0~31) 0: The Spinlock is free, 1: The Spinlock is taken.

3.14.5.3. Spinlock Lock Register N (N=0 to 31)(Default Value: 0x00000000)

Offset:0x100+N*0x4 (N=0~31)			Register Name: SPINLOCKN_LOCK_REG
Bit	R/W	Default/Hex	Description
31:1	/	/	/
0	R/W	0x0	TAKEN. Lock State. Read 0x0: The lock was previously Not Taken (free).The requester is granted the lock. Write 0x0: Set the lock to Not Taken (free).

			<p>Read 0x1: The lock was previously Taken. The requester is not granted the lock and must retry.</p> <p>Write 0x1: No update to the lock value.</p>
--	--	--	--

3.14.6. Programming Guidelines

Take CPU0's synchronization with CPUS with Spinlock0 for an example, CPU0 takes the spinlock0 firstly in the instance:

CPU0

 Step 1: CPU0 initializes Spinlock

```
writel(readl(BUS_CLK_GATING_REG1)|(1<<22), BUS_CLK_GATING_REG1); //open Spinlock clock gating
writel (readl(BUS_SOFT_RST_REG1)|(1<<22), BUS_SOFT_RST_REG1); //software reset Spinlock
```

Step 2: CPU0 requests to take spinlock0

```
rdata=readl(SPINLOCK_SYSTATUS_REG0); //check lock register0 status, if it is taken, check till
if(rdata != 0) rdata=readl(SPINLOCK_SYSTATUS_REG0); // lock register0 is free
:
:
rdata=readl(SPINLOCKN_LOCK_REG0); //request to take spinlock0, if fail, retry till
if(rdata != 0) rdata=readl(SPINLOCKN_LOCK_REG0); // lock register0 is taken
:
:
----- CPU0 critical code section -----
```

Step 3: CPU0 free spinlock0

```
writel (0, SPINLOCKN_LOCK_REG0); //CPU0 frees spinlock0
```

Step 4: CPU0 waits for CPUS' freeing spinlock0

```
writel (readl(SPINLOCK_SYSTATUS_REG0) == 1); // CPU0 waits for CPUS' freeing spinlock0
```

CPUS

 Step 1: CPU0 has taken spinlock0, CPUS waits for CPU0' freeing spinlock0

```
while(readl(SPINLOCK_SYSTATUS_REG0) == 1); // CPUS waits for CPU0' freeing spinlock0
```

Step 2: CPUS takes spinlock0 and go on

----- CPU0 critical code section -----

Step 3: CPUS frees spinlock0

```
writel (0, SPINLOCKN_LOCK_REG0); //CPUS frees spinlock0
```

3.15. Crypto Engine

3.15.1. Overview

The Crypto Engine(CE) is one encrypt/ decrypt function accelerator. It is suitable for a variety of applications. It can support both encryption/decryption and signature/verification, calculate the hash value. Several modes are supported by the Crypto Engine. The Crypto Engine has a special internal DMA(IDMA) controller to transfer data .

It includes the following features:

- Support symmetrical algorithm :AES, DES, TDES
- Support asymmetrical algorithm :RSA512/1024/2048-bits
- Support secure Hash algorithm: MD5, SHA-1,SHA-224,SHA-256, HMAC-SHA1,HMAC-SHA256
- Support 160-bits hardware PRNG with 175-bits seed
- Support 256-bits hardware TRNG
- Support ECB, CBC, CTR modes for DES/TDES
- Support ECB, CBC, CTR, CTS modes for AES
- Support 128-bits, 192-bits and 256-bits key size for AES
- Support multi-package mode for MD5/SHA-1/SHA-224/SHA-256/HMAC
- Support IDMA mode
- Support secure and non-secure interface respectively

3.15.2. Functionalities Description

3.15.2.1. Block Diagram

Figure 3-13 shows the block diagram of Crypto Engine.

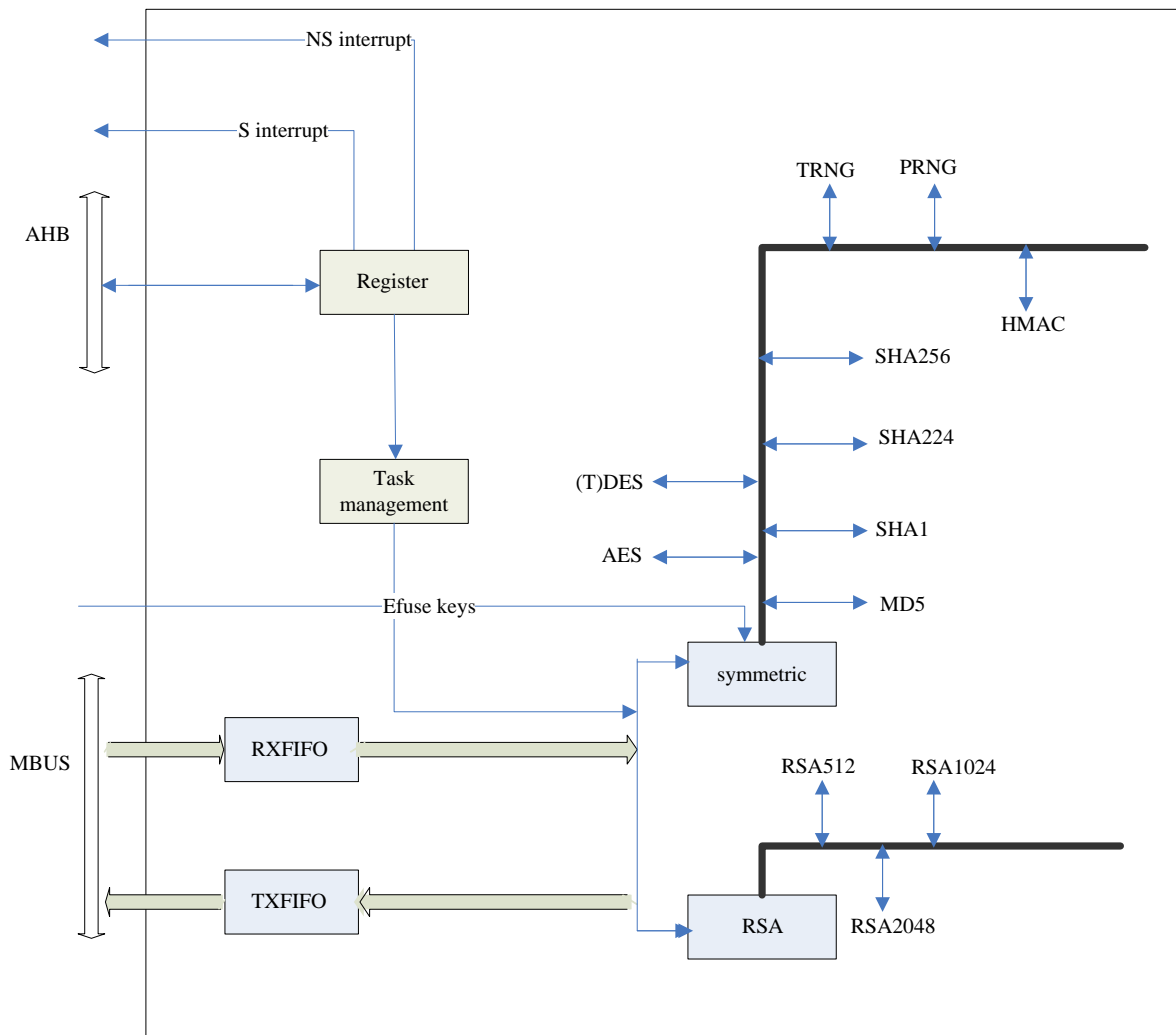

Figure 3-13. Crypto Engine Block Diagram

3.15.2.2. Crypto Engine with keysram

In **Figure 3-14**, keysram space composed by HDCP key,EK and BSSK.AES and RSA belong to CE,RSSK in efuse directly links to CE,and Only CE in secure mode can be read RSSK .

The path between CE and keysram explain as following:

- (1) CE in secure mode uses RSSK as key,The ciphertext of HDCP key in external memory is decrypted by AES,the result writes in HDCP key memory of keysram.AES has only the writing privilege for HDCP key memory.
- (2) In order to verify that HDCP key in external memory has not been tampered,after the plaintext of HDCP key writed in keysram,the digest of HDCP key can be obtained by MD5.We can compare the value and the digest that in advance wrote to efuse, if the compared result is consistency,it explains that HDCP key has not been tampered.
- (3) CE in secure mode uses RSSK as key, The ciphertext of EK in external memory is decrypted by AES,the result writes in EK memory of keysram.AES has only the writing privilege for EK memory.
- (4) In order to verify that EK in external memory has not been tampered,after the plaintext of EK writed in keysram,the digest of EK can be obtained by MD5.We can compare the value and the digest that in advance

wrote to efuse, if the compared result is consistency, it explains that EK has not been tampered.

- (5) CE in secure mode uses RSSK as key, The ciphertext of EK in external memory is decrypted by AES, the result writes in EK memory of keysram. At the same time, AES could use BSSK as key to encrypt and decrypt. So AES has the reading and writing privilege for BSSK.
- (6) HDMI and HDCP key memory have the dedicated channel, HDMI has the reading privilege for HDCP key memory at any time.
- (7) RSA has only the reading privilege for EK memory.

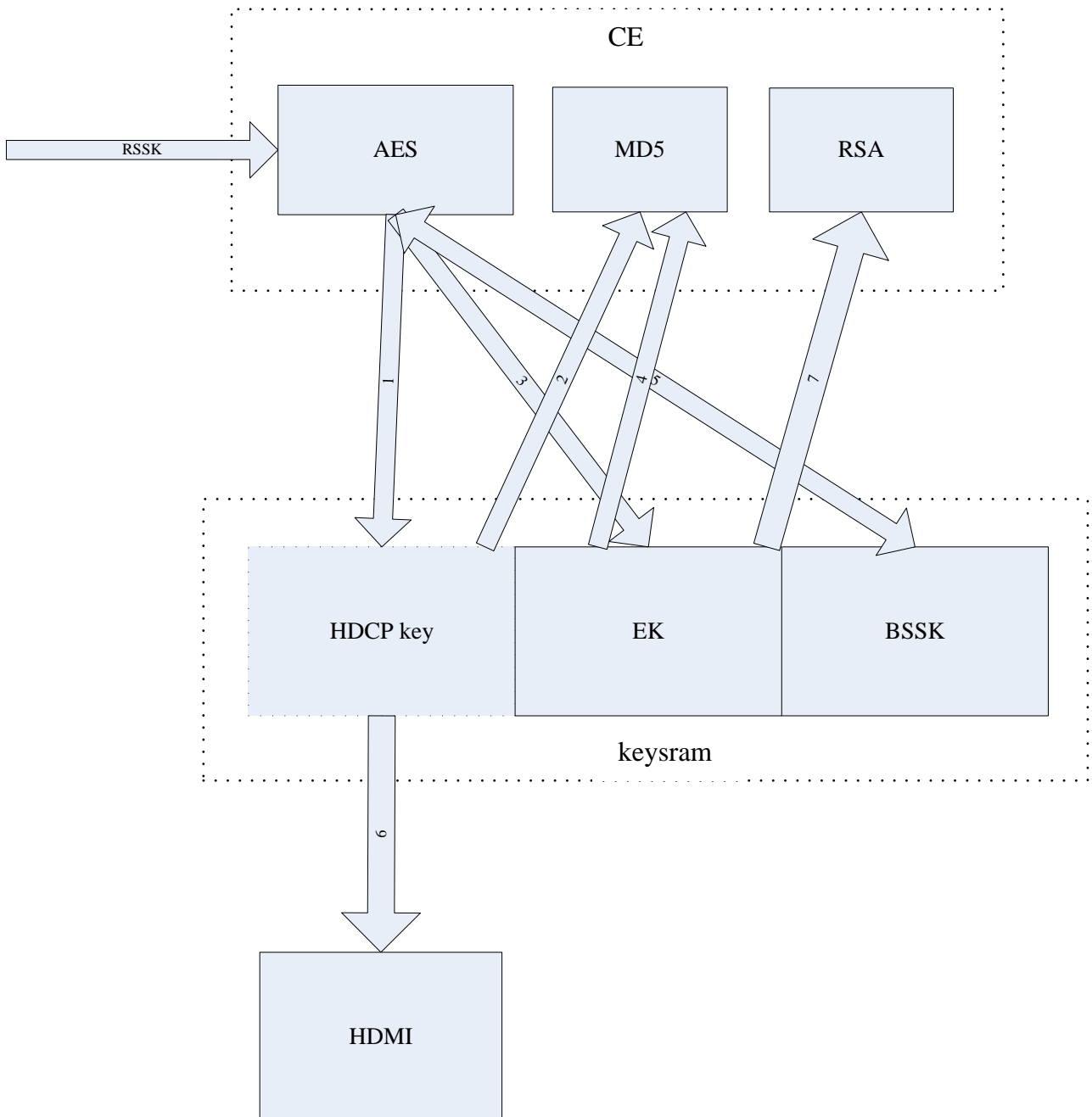

Figure 3-14. Crypto Engine with Keysram

3.15.2.3. Crypto Engine Task Descriptor

Figure 3-15 shows the block diagram of Crypto Engine Task Chaining.

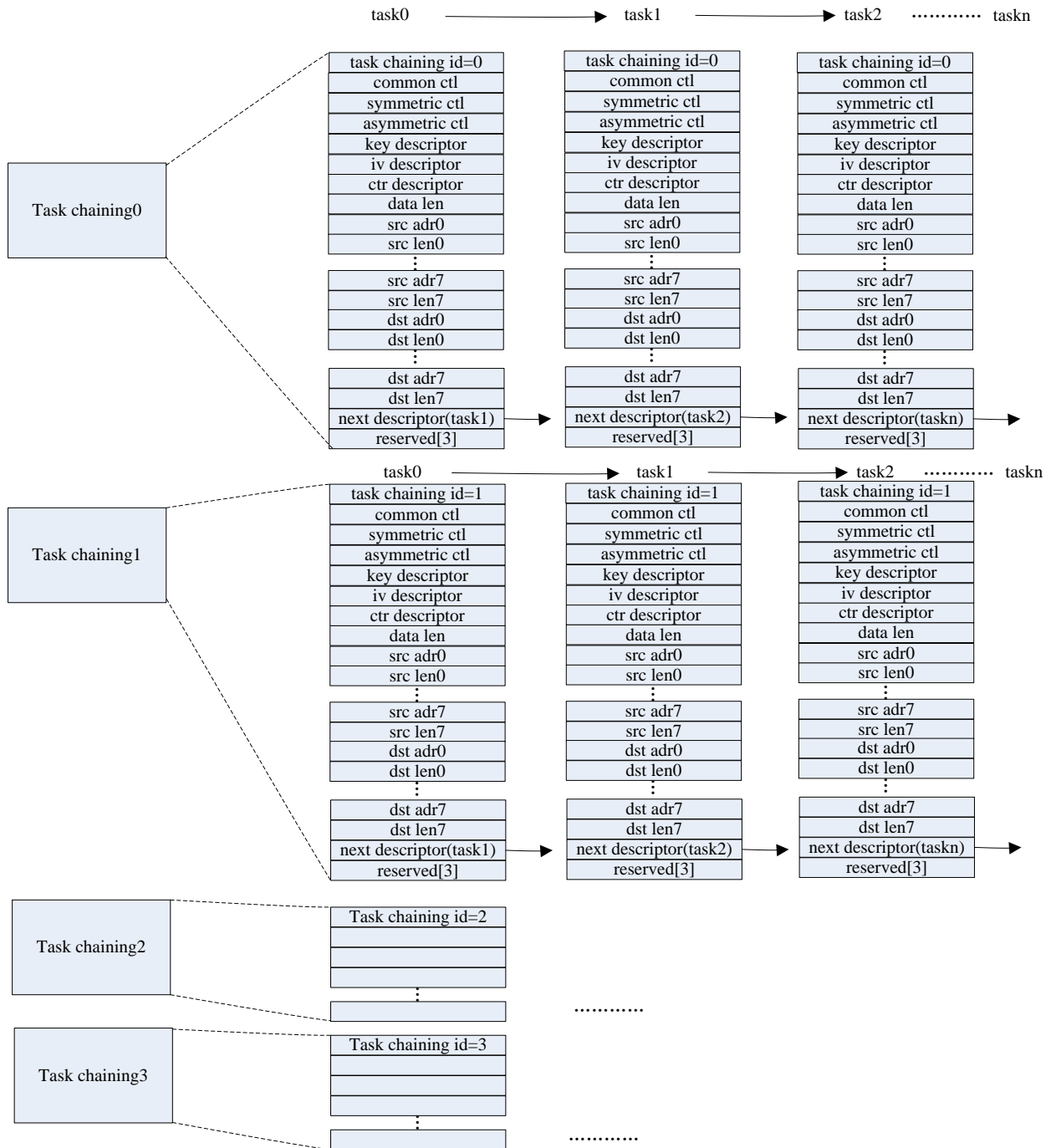

Figure 3-15. Crypto Engine Task Chaining Block Diagram

In the above figure, Every CE task descriptor is 44*4Byte memory.

CE contains secure CE and non-secure CE, which corresponds to the different base address, but the registers design are the same. CE supports 4 task channels, every task chain corresponds to one task id, every task channel could do multiple tasks, which is based on whether the next descriptor of every task descriptor is 0. The task id in the same task channel is the same.

data len = src len0 + src len1 + + src len7, they are word in unit, when src len0 = data len, others (src len1.....src len7) must be wrote to 0; but for AES CTS, data len is byte in unit, src len0~7 are word in unit.

Next descriptor = 0, it denotes that there are not the new tasks; Next descriptor != 0, it denotes that there are the new tasks, which is the head address of the next task descriptor.

When the source of symmetrical algorithm divide into multiple packages to encrypt or decrypt, the iv value of the next package store at the ctr descriptor address for ctr/cfb/ofb mode; the iv value of the next package are the result of the last ciphertext.

The address of src/dst/key/iv/ctr in the descriptor align with word.

For the bit description of common ctl, symmetric ctl, asymmetric ctl descriptor are as following:

task_descriptor_queue common control bitmap(32bit)

Bit	Description
31	interrupt enable for current task 0: disable interrupt 1: enable interrupt
30:17	/
16	IV_Mode IV Steady of SHA-1/SHA-224/SHA-256/MD5 0: use initial constants defined in FIPS-180 1: Arbitrary IV
15	HMAC plaintext last 0: not the last HMAC plaintext package 1: the last HMAC plaintext package
14:9	/
8	SS_OP_DIR SS Operation Direction 0: Encryption 1: Decryption
7	/
6:0	SS_Method 0: AES 1: DES 2: Triple DES (3DES) 3~15: reserved 16: MD5

17: SHA-1
18: SHA-224
19: SHA-256
20: /
21: /
22: HMAC-SHA1
23:HMAC-SHA256
24~31: reserved
32: RSA
33~47: reserved
48: TRNG
49: PRNG
others: reserved

task_descriptor_queue symmetric control(32bit)

Bit	Description
31:24	/
23:20	SKEY_Select key select for AES 0: Select input SS_KEYx (Normal Mode) 1: Select {SSK} 2: Select {HUK} 3: Select {RSSK} 4-7: Reserved 8-15: Select internal Key n (n from 0 to 7)
19:18	/
17	/
16	AES_CTS_Last_Block_Flag When set to "1", it means this is the last package for AES-CTS mode. (the size of the last block >128bit)
15:12	/
11:8	SS_OP_Mode SS Operation Mode 0: Electronic Code Book (ECB) mode 1: Cipher Block Chaining (CBC) mode 2: Counter (CTR) mode 3: Ciphertext Stealing (CTS) mode Others: reserved
7:4	/
3:2	CTR_Width Counter Width for CTR Mode 0: 16-bits Counter

	1: 32-bits Counter 2: 64-bits Counter 3: 128-bits Counter
1:0	AES_Key_Size 0: 128-bits 1: 192-bits 2: 256-bits 3: Reserved

task_descriptor_queue asymmetric control(32bit)

Bit	Description
31	/
30:28	RSA_Public_Modular_Width 0:512 bit 1:1024 bit 2:2048 bit Others: reserved
27:0	/

3.15.3. Crypto Engine Register List

Module Name	Base Address
CE_NS	0x01C15000
CE_S	0x01C15800

Register Name	Offset	Description
CE_TDQ	0x00	Task Descriptor Queue Address
CE_CTR	0x04	Gating Control Register
CE_ICR	0x08	Interrupt Control Register
CE_ISR	0x0c	Interrupt Status Register
CE_TLR	0x10	Task Load Register
CE_TSR	0x14	Task Status Register
CE_ESR	0x18	Task Error type Register
CE_CSAR	0x24	Current Source Address Register
CE_CDAR	0x28	Current Destination Address Register
CE_TPR	0x2c	Throughput Register

3.15.4. Crypto Engine Register Description

3.15.4.1. Crypto Engine Task Descriptor Queue Register(Default Value: 0x00000000)

Offset: 0x00			Register Name: CE_TDQ
Bit	R/W	Default/Hex	Description
31:0	R/W	0	Task_Descriptor_Queue_Address

3.15.4.2. Crypto Engine Control Register(Default Value: 0x00000000)

Offset: 0x04			Register Name: CE_CTR
Bit	R/W	Default/Hex	Description
31:4	/	/	/
3	R/W	0	RSA_CLK_Gating_Enable(read only for NS world) 0: RSA clk gating enable 1: RSA clk gating disable
2:0	R	x	DIE_ID Die Bonding ID

3.15.4.3. Crypto Engine Interrupt Control Register(Default Value: 0x00000000)

Offset: 0x08			Register Name: CE_ICR
Bit	R/W	Default/Hex	Description
31:4	/	/	/
3:0	R/W	0	Task chaining0-3_interrupt_enable 0: interrupt disable 1: interrupt enable

3.15.4.4. Crypto Engine Interrupt Status Register(Default Value: 0x00000000)

Offset: 0x0C			Register Name: CE_ISR
Bit	R/W	Default/Hex	Description
31:4	/	/	/
3:0	R/W	0	Task chaining0-3_End_Pending 0: busy 1: task end It indicates that the processing of encrypt /signing or decrypt/verification has been completed .

			Notes: Write '1' to clear it.
--	--	--	-------------------------------

3.15.4.5. Crypto Engine Task Load Register(Default Value: 0x00000000)

Offset: 0x10			Register Name: CE_TLR
Bit	R/W	Default/Hex	Description
31:1	/	/	/
0	R/W	0	Task_Load When set , SS starts to load the configure of task from task descriptor queue and start to perform the task if task FIFO is not full.

3.15.4.6. Crypto Engine Task Status Register(Default Value: 0x00000000)

Offset: 0x14			Register Name: CE_TSR
Bit	R/W	Default/Hex	Description
31:2	/	/	/
1:0	R	0	Current task in run 0: task chaining0 1: task chaining1 2: task chaining2 3: task chaining3

3.15.4.7. Crypto Engine Error Status Register(Default Value: 0x00000000)

Offset: 0x18			Register Name: CE_ESR
Bit	R/W	Default/Hex	Description
31:16	/	/	/
15:12	R	0	Task channel3 error type xxx1: algorithm not support xx1x: data length error x1xx: keysram access error for AES. Write '1' to clear. 1xxx: reserved
11:8	R	0	Task channel2 error type xxx1: algorithm not support xx1x: data length error x1xx: keysram access error for AES. Write '1' to clear. 1xxx: reserved
7:4	R	0	Task channel1 error type xxx1: algorithm not support xx1x: data length error

			x1xx: keysram access error for AES. Write '1' to clear. 1xxx: reserved
3:0	R	0	Task channel0 error type xxxlgorithm not support xx1x: data length error x1xx: keysram access error for AES. Write '1' to clear. 1xxx: reserved

3.15.4.8. Crypto Engine Current Source Address Register(Default Value: 0x00000000)

Offset: 0x24			Register Name: CE_CSAR
Bit	R/W	Default/Hex	Description
31:0	R	0	Current source address of the executing task

3.15.4.9. Crypto Engine Current Destination Address Register(Default Value: 0x00000000)

Offset: 0x28			Register Name: CE_CDAR
Bit	R/W	Default/Hex	Description
31:0	R	0	Current destination address of the executing task

3.15.4.10. Crypto Engine Throughput Register(Default Value: 0x00000000)

Offset: 0x2C			Register Name: CE_TPR
Bit	R/W	Default/Hex	Description
31:0	R/W	0	It indicates the throughput of data from the whole processing. Notes: Write '0' to clear it.

3.15.5. Crypto Engine Clock Requirement

Clock Name	Description	Requirement
ahb_clk	AHB bus clock	>=24MHz
m_clk	MBUS clock	>=24MHz
ce_clk	Crypto Engine serial clock	<= 300MHz && >=24MHz

3.15.6. Programming Guidelines

- (1) The module provides two interfaces to software. Secure CPU uses the interface of 0x800 offset, non-secure

CPU uses the interface of 0x0 offset.

- (2) The task is approached by the task descriptor mode,so before start to the load bit,the task descriptor is wrote in the specified address,and the task descriptor address register is configured.After the load bit is ensure to be low,the next task could be configured.
- (3) The writing/reading function of the data is completed by the internal DMA,if the data is in cache,the cache need refresh before the task loaded,so that the data in the address is latest.
- (4) The task descriptor supports 8 source scatters and 8 destination scatters.When configuring the scatter address and size,the continue scatter address and size should be used.Except the active scatters,the size of other scatter need be configured to 0.
- (5) data len= src len0 + src len1 +.....+src len7,they are word in unit,when src len0 = data len,others(src len1.....src len7)must be wrote to 0;but for AES CTS,data len is byte in unit,src len0~7 are word in unit.
- (6) Secure CPU and non-secure CPU support separately 4 task channels, every task channel has a interrupt enable bit and interrupt status bit.
- (7) The enable bit of the interrupt register represents channel interrupt,the 31bit of the first word in the task descriptor represents the interrupt enable of every task,only the two bits are 1 at the same time,the interrupt could pend when the task is completed.
- (8) The input data sequence of RSA is that the low word store in the low address.
- (9) SSK/HUK/RSSK in efuse directly links to CE,and Only CE in secure mode can read SSK/HUK/RSSK.
- (10)CE in secure mode uses RSSK as key,The ciphertext of HDCP/EK/BSSK key in external memory is decrypted by AES,the result writes in HDCP/EK/BSSK key memory of keysram.AES has only the writing privilege for the keysram ,and to prevent the key leaked, the result only can be wrote in the keysram address when AES decrypt by RSSK.
- (11)For SHA1/SHA224/SHA256/SHA384/SHA512,It should be noted the sequence of the initial hash value.

SHA1/SHA224/SHA256/SHA384/SHA512 is the big-endian algorithm, within each word,the most significant bit is stored in the left-most bit position.For example,the initial hash value of SHA1 in Fips180-2, $H^{(0)}$ shall consist of the following five 32-bit words,in hex:

- $H_0^{(0)} = 67452301$
- $H_1^{(0)} = \text{efcdab89}$
- $H_2^{(0)} = 98badcfe$
- $H_3^{(0)} = 10325476$
- $H_4^{(0)} = \text{c3d2e1f0}$

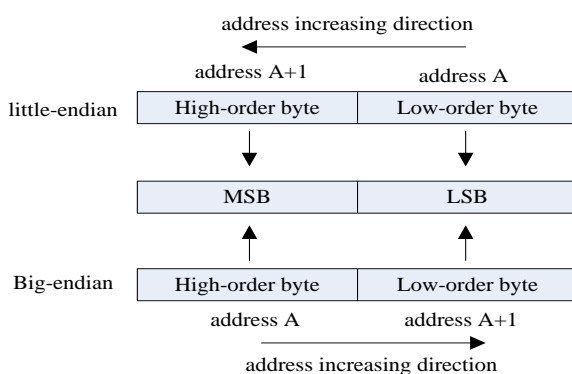

The default access mode of ARM is litter-endian.So When we write the initial value in the IV descriptor address, according to the following array input sequence:

For SHA1:

```
unsigned char iv_sha1[20]={  
0x67,0x45,0x23,0x01,0xef,0xcd,0xab,0x89,  
0x98,0xba,0xdc,0xfe,0x10,0x32,0x54,0x76,  
0xc3,0xd2,0xe1,0xf0};
```

Then:

```
IV descriptor address :      0x01234567  
IV descriptor address +0x4:  0x89abcdef  
IV descriptor address +0x8:  0xfedcba98  
IV descriptor address +0xC:  0x76543210  
IV descriptor address +0x10: 0xf0e1d2c3
```

For SHA224:

```
unsigned char iv_sha224[32]={  
0xc1,0x05,0x9e,0xd8,0x36,0x7c,0xd5,0x07,  
0x30,0x70,0xdd,0x17,0xf7,0x0e,0x59,0x39,  
0xff,0xc0,0x0b,0x31,0x68,0x58,0x15,0x11,  
0x64,0xf9,0x8f,0xa7,0xbe,0xfa,0x4f,0xa4};
```

For SHA256:

```
unsigned char iv_sha256[32]={  
0x6a,0x09,0xe6,0x67,0xbb,0x67,0xae,0x85,  
0x3c,0x6e,0xf3,0x72,0xa5,0x4f,0xf5,0x3a,  
0x51,0x0e,0x52,0x7f,0x9b,0x05,0x68,0x8c,  
0x1f,0x83,0xd9,0xab,0x5b,0xe0,0xcd,0x19};
```

For SHA384:

```
unsigned char iv_sha384[64]={  
0xcb,0xbb,0x9d,0x5d,0xc1,0x05,0x9e,0xd8,  
0x62,0x9a,0x29,0x2a,0x36,0x7c,0xd5,0x07,  
0x91,0x59,0x01,0x5a,0x30,0x70,0xdd,0x17,  
0x15,0x2f,0xec,0xd8,0xf7,0x0e,0x59,0x39,  
0x67,0x33,0x26,0x67,0xff,0xc0,0x0b,0x31,  
0x8e,0xb4,0x4a,0x87,0x68,0x58,0x15,0x11,  
0xdb,0x0c,0x2e,0x0d,0x64,0xf9,0x8f,0xa7,  
0x47,0xb5,0x48,0x1d,0xbe,0xfa,0x4f,0xa4};
```

For SHA512:

```
unsigned char iv_sha512[64]={  
0x6a,0x09,0xe6,0x67,0xf3,0xbc,0xc9,0x08,  
0xbb,0x67,0xae,0x85,0x84,0xca,0xa7,0x3b,  
0x3c,0x6e,0xf3,0x72,0xfe,0x94,0xf8,0x2b,  
0xa5,0x4f,0xf5,0x3a,0x5f,0x1d,0x36,0xf1,  
0x51,0x0e,0x52,0x7f,0xad,0xe6,0x82,0xd1,  
0x9b,0x05,0x68,0x8c,0x2b,0x3e,0x6c,0x1f,  
0x1f,0x83,0xd9,0xab,0xfb,0x41,0xbd,0x6b,  
0x5b,0xe0,0xcd,0x19,0x13,0x7e,0x21,0x79};
```

3.16. Secure Memory Controller

3.16.1. Overview

The SMC is an Advanced Microcontroller Bus Architecture compliant System-on-Chip peripheral. It is a high-performance, area-optimized address space controller with on-chip AMBA bus interfaces that conform to the AMBA Advanced extensible Interface protocol and the AMBA Advanced Peripheral Bus protocol.

You can configure the SMC to provide the optimum security address region control functions required for your intended application.

The SMC includes the following features:

- Enables you to program security access permissions each address region.
- Permits the transfer of data between master and slave only if the security status of the AXI transaction matches the security settings of the memory region it addresses.

3.16.2. Functionalities Description

By default, the SMC performs read or write speculative that means it forwards an AXI transaction address to a slave, before it verifies that the AXI transaction is permitted to read address or write address respectively.

The SMC only permits the transfer of data between its AXI bus interfaces, after verifying the access that the read or write access is permitted respectively. If the verification fails, then it prevents the transfer of data between the master and slave as Denied AXI transactions.

When the speculative accesses are disabled, the SMC verifies the permissions of the access before it forwards the access to the slave. If the SMC:

- Permits the access, it commences an AXI transaction to the slave, and it adds one clock latency.
- Denies the access, it prevents the transfer of data between the master and slave. In this situation, the slave is unaware when the SMC prevents the master from accessing the slave.

3.16.2.1. DRM Block Diagram

- G. NS.M stands for General Non-secure Master
- D. NS.M stands for Non-secure Master appointed by DRM
- S.M. stands for Secure Mater

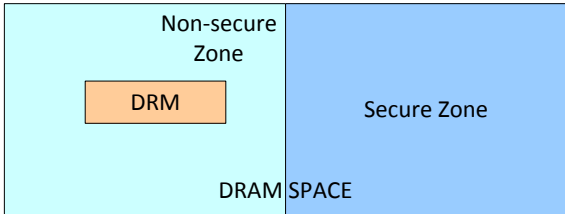

- G.NS.M only can read data from NSZ and write data into NSZ
- D.NS.M can read data from NSZ and DRM, but only can write data into DRM
- S.M can read data from the whole DRAM SPACE

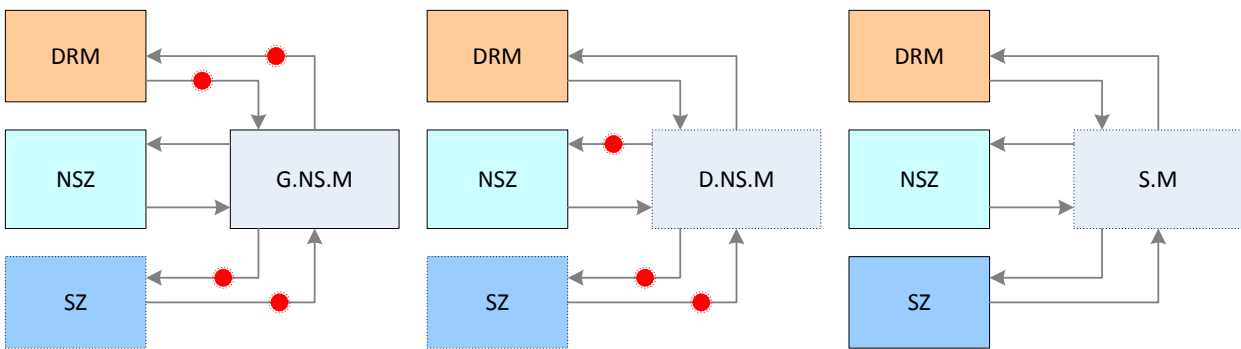

Figure 3-16. DRM Block Diagram

3.16.2.2. Master ID Table

Table 3-2. Master and Master ID

ID	Master	ID	Master
0	CPU	12	VE
1	GPU	13	CSI
2	CPUS	14	NAND
3	ATH (test interface for AHB)	15	Crypto Engine
4	USB-OTG/USB-OTG-HCI	16	DE_RT-MIXER0
5	SMHC0	17	DE_RT-MIXER1
6	SMHC1	18	DE_RT-WB
7	SMHC2	19	DE_ROT
8	USB-HCI0	20	
9		21	TS
10	EMAC	22	DE Interlace
11	DMA	23	

3.16.2.3. Region Size Table

Table 3-3. Region Size

Size<n>	Size of region<n>	Base address constraints
b000000-b001101	Reserved	-
b001110	32KB	-
b001111	64KB	Bit [15] must be zero
b010000	128KB	Bits [16:15] must be zero
b010001	256KB	Bits [17:15] must be zero
b010010	512KB	Bits [18:15] must be zero
b010011	1MB	Bits [19:15] must be zero
b010100	2MB	Bits [20:15] must be zero
b010101	4MB	Bits [21:15] must be zero
b010110	8MB	Bits [22:15] must be zero
b010111	16MB	Bits [23:15] must be zero
b011000	32MB	Bits [24:15] must be zero
b011001	64MB	Bits [25:15] must be zero
b011010	128MB	Bits [26:15] must be zero
b011011	256MB	Bits [27:15] must be zero
b011100	512MB	Bits [28:15] must be zero
b011101	1GB	Bits [29:15] must be zero
b011110	2GB	Bits [30:15] must be zero
b011111	4GB	Bits [31:15] must be zero
B100000	8GB	Bits [32:15] must be zero

3.16.2.4. Security inversion is disabled

Table 3-4. Region security permissions

SPN field	Secure Read	Secure Write	Non-secure Read	Non-secure Write
4b0000	No	No	No	No
4b0100	No	Yes	No	No
4b0001, 4b0101	No	Yes	No	Yes
4b1000	Yes	No	No	No
4b0010, 4b1010	Yes	No	Yes	No
4b1100	Yes	Yes	No	No
4b1001, 4b1101	Yes	Yes	No	Yes
4b0110, 4b1110	Yes	Yes	Yes	No
4b0011-4b1111	Yes	Yes	Yes	Yes

3.16.2.5. Security inversion is enabled

If you enable security inversion, the SMC permits you to program any combination of security permissions as [Table 3-5](#) shows.

Table 3-5. Region security permissions

SPN field	Secure Read	Secure Write	Non-secure Read	Non-secure Write
4b0000	No	No	No	No
4b0001	No	No	No	Yes
4b0010	No	No	Yes	No
4b0011	No	No	Yes	Yes
4b0100	No	Yes	No	No
4b0101	No	Yes	No	Yes
4b0110	No	Yes	Yes	No
4b0111	No	Yes	Yes	Yes
4b1000	Yes	No	No	No
4b1001	Yes	No	No	Yes
4b1010	Yes	No	Yes	No
4b1011	Yes	No	Yes	Yes
4b1100	Yes	Yes	No	No
4b1101	Yes	Yes	No	Yes
4b1110	Yes	Yes	Yes	No
4b1111	Yes	Yes	Yes	Yes

3.16.3. SMC Register List

Module Name	Base Address
SMC	0x01C1E000

Register Name	Offset	Description
SMC_CONFIG_REG	0x0	SMC Configuration Register
SMC_ACTION_REG	0x4	SMC Action Register
SMC_LD_RANGE_REG	0x8	SMC Lock Down Range Register
SMC_LD_SELECT_REG	0xC	SMC Lock Down Select Register
SMC_INT_STATUS_REG	0x10	SMC Interrupt Status Register
SMC_INT_CLEAR_REG	0x14	SMC Interrupt Clear Register
SMC_MST_BYP_REG	0x18	SMC Master Bypass Register
SMC_MST_SEC_REG	0x1C	SMC Master Secure Register
SMC_FAIL_ADDR_REG	0x20	SMC Fail Address Register
SMC_FAIL_CTRL_REG	0x28	SMC Fail Control Register
SMC_FAIL_ID_REG	0x2C	SMC Fail ID Register
SMC_SPECU_CTRL_REG	0x30	SMC Speculation Control Register

SMC_SEC_INV_EN_REG	0x34	SMC Security Inversion Enable Register
SMC_MST_ATTRI_REG	0x48	SMC Master Attribute Register
DRM_MASTER_EN_REG	0x50	DRM Master Enable Register
DRM_ILLACCE_REG	0x58	DRM Illegal Access Register
DRM_STATADDR_REG	0x60	DRM Start Address Register
DRM_ENDADDR_REG	0x68	DRM End Address Register
SMC_REGION_SETUP_LO_REG	0x100+N*0x10	Region Setup Low Register N (N=0,1,2,3,4,5,6,7,8,9,10,11,12,13,14,15)
SMC_REGION_SETUP_HI_REG	0x104+N*0x10	Region Setup High Register N (N=0,1,2,3,4,5,6,7,8,9,10,11,12,13,14,15)
SMC_REGION_ATTR_REG	0x108+N*0x10	Region Attribute Register N (N=0,1,2,3,4,5,6,7,8,9,10,11,12,13,14,15)

3.16.4. SMC Register Description

3.16.4.1. SMC Configuration Register(Default Value: 0x00001F0F)

Offset: 0x0			Register Name: SMC_CONFIG_REG
Bit	R/W	Default/Hex	Description
31:14	/	/	/
13:8	R	0x1F	ADDR_WIDTH_RTN. Address width. Return the width of the AXI address bus. 6'b 000000-6'b011110 reserved. 6'b 011111 = 32-bit 6'b 111111 = 64-bit
7:4	/	/	/
3:0	R	0xF	REGIONS_RTN. Returns the number of the regions that the SMC provides. 4'b0000 = reserved 4'b0001 = 2 regions 4'b1111 = 16 regions.

3.16.4.2. SMC Action Register(Default Value: 0x00000001)

Offset: 0x4			Register Name: SMC_ACTION_REG
Bit	R/W	Default/Hex	Description
31:2	/	/	/

1:0	R/W	0x1	<p>SMC_INT_RESP.</p> <p>Control how the SMC uses the bresps[1:0], rresps[1:0], and smc_int signals when a region permission failure occurs:</p> <p>2'b00 = sets smc_int LOW and issues an OKEY response</p> <p>2'b01 = sets smc_int LOW and issues a DECERR response</p> <p>2'b10 = sets smc_int HIGH and issues an OKEY response</p> <p>2'b11 = sets smc_int HIGH and issues a DECERR response</p>
-----	-----	-----	---

Note:This action is only valid for CPU access, not for MBUS and DMA access.

3.16.4.3. SMC Lockdown Range Register(Default Value: 0x00000000)

Offset: 0x8			Register Name: SMC_LD_RANGE_REG
Bit	R/W	Default/Hex	Description
31	R/W	0x0	<p>LOCKDOWN_EN.</p> <p>When set to 1, it enables the lockdown_regions field to control the regions that are to be locked.</p>
30:4	/	/	/
3:0	R/W	0x0	<p>NO_REGIONS_LOCKDOWN.</p> <p>Control the number of regions to lockdown when the enable bit is set to 1.</p> <p>4'b0000 = region no_of_regions-1 is locked</p> <p>4'b0001 = region no_of_regions-1 to region no_of_regions-2 are locked</p> <p>.....</p> <p>4'b1111 = region no_of_regions-1 to region no_of_regions-16 are locked</p>

Note1: No_of_regions is the value of the no_of_regions field in the configuration register.

Note2: The value programmed in lockdown_range register must not be greater than no_of_regions-1 ,else all regions are locked.

3.16.4.4. SMC Lockdown Select Register(Default Value: 0x00000000)

Offset: 0xC			Register Name: SMC_LD_SELECT_REG
Bit	R/W	Default/Hex	Description
31:3	/	/	/
2	R/W	0x0	<p>ACCESS_TYPE_SPECU.</p> <p>Modify the access type of the speculation_control register:</p> <p>0: no effect. The speculation register remains RW.</p> <p>1: speculation_control register is RO</p>
1	R/W	0x0	<p>ACCESS_TYPE_SEC_INV_EN.</p> <p>Modify the access type of the security_inversion_en register.</p> <p>0: no effect. Security_inversion_en register remains RW.</p> <p>1: security_inversion_en register is RO</p>

0	R/W	0x0	ACCESS_TYPE_LOCKDOWN_RANGE. Modify the access type of the lockdown_range register. 0: no effect. Lockdown_range register remains RW 1: lockdown_range register is RO.
---	-----	-----	--

3.16.4.5. SMC Interrupt Status Register(Default Value: 0x00000000)

Offset: 0x10			Register Name: SMC_INT_STATUS_REG
Bit	R/W	Default/Hex	Description
31:2	/	/	/
1	R	0x0	INT_OVERRUN. When set to 1, it indicates the occurrence of two or more region permission failure since the interrupt was last cleared.
0	R	0x0	INT_STATUS. Return the status of the interrupt. 0: interrupt is inactive. 1: interrupt is active.

3.16.4.6. SMC Interrupt Clear Register(Default Value: 0x00000000)

Offset: 0x14			Register Name: SMC_INT_CLEAR_REG
Bit	R/W	Default/Hex	Description
31:0	R/W	0x0	SMC_CLR_REG. Write any value to the int_clear register sets the : Status bit to 0 in the int_status register Overrun bit to 0 in the int_status register. Note: It will be auto cleared after the write operation.

3.16.4.7. SMC Master Bypass Register(Default Value: 0xFFFFFFFF)

Offset: 0x18			Register Name: SMC_MST_BYP_REG
Bit	R/W	Default/Hex	Description
31:0	R/W	0xFFFFFFFF	SMC_MASTER_BYPASS_EN. SMC Master n Bypass Enable. (n = 0~31, see the Table 3-2 . MASTER and MASTER ID for detail.) Note: Bit[31:0] stand for Master ID [31:0] If the master n bypass enable is set to 0, the master n access must be through the SMC. 0: Bypass Disable 1: Bypass Enable.

3.16.4.8. SMC Master Secure Register(Default Value: 0x00000000)

Offset: 0x1C			Register Name: SMC_MST_SEC_REG
Bit	R/W	Default/Hex	Description
31:0	R/W	0x0	SMC_MASTER_SEC. SMC Master n Secure Configuration.(n = 0~31, see the Table 3-2 for detail) 0: secure 1: non-secure.

3.16.4.9. SMC Fail Address Register(Default Value: 0x00000000)

Offset: 0x20			Register Name: SMC_FAIL_ADDR_REG
Bit	R/W	Default/Hex	Description
31:0	R	0x0	FIRST_ACCESS_FAIL. Return the address bits [31:0] of the first access to fail a region permission check after the interrupt was cleared. For external 16-bit DDR2, the address [2:0] is fixed to zero. For external 32-bit DDR2 and 16-bit DDR3, the address [3:0] is fixed to zero. For external 32-bit DDR3, the address [4:0] is fixed to zero.

Note:If the master ID="SRAM" and the register value is between 0x80000 to 0xBFFFF, the real address should be divide by 4.

3.16.4.10. SMC Fail Control Register(Default Value: 0x00000000)

Offset: 0x28			Register Name: SMC_FAIL_CTRL_REG
Bit	R/W	Default/Hex	Description
31:25	/	/	/
24	R	0x0	READ_WRITE. This bit indicates whether the first access to fail a region permission check was a write or read as: 0 = read access 1 = write access.
23:22	/	/	/
21	R	0x0	NON_SECURE. After clearing the interrupt status, this bit indicates whether the first access to fail a region permission check was non-secure. Read as: 0 = secure access

			1 = non-secure access
20	R	0x0	PRIVILEGED. After clearing the interrupt status, this bit indicates whether the first access to fail a region permission check was privileged. Read as: 0 = unprivileged access. 1 = privileged access
19:0	/	/	/

3.16.4.11. SMC Fail ID Register(Default Value: 0x00001F00)

Offset: 0x2C			Register Name: SMC_FAIL_ID_REG
Bit	R/W	Default/Hex	Description
31:24	/	/	/
23:16	R	0x0	FAIL_BST_LEN. Fail burst length. 0 = 1 word length 0xf =16 words length
15:8	/	/	/
7:0	R	0x0	FAIL_MASTER_ID. Fail Master ID. The value stands for master id, see the Table 3-2 MASTER and MASTER ID for detail.

3.16.4.12. SMC Speculation Control Register(Default Value: 0x00000000)

Offset: 0x30			Register Name: SMC_SPECU_CTRL_REG
Bit	R/W	Default/Hex	Description
31:2	/	/	/
1	R/W	0x0	WRITE_SPECU. Write_speculation. Control the write access speculation: 0 = write access speculation is enabled 1 = write access speculation is disabled.
0	R/W	0x0	READ_SPECU. Read_speculation. Control the read access speculation: 0 = read access speculation is enabled 1 = read access speculation is disabled.

3.16.4.13. SMC Security Inversion Enable Register(Default Value: 0x00000000)

Offset: 0x34			Register Name: SMC_SEC_INV_EN_REG
Bit	R/W	Default/Hex	Description
31:1	/	/	/
0	R/W	0x0	SEC_INV_EN. Security_inversion_en. Controls whether the SMC permits security inversion to occur. 0 = security inversion is not permitted. 1 = security inversion is permitted. This enables a region to be accessible to masters in Non-secure state but not accessible to masters in Secure state. See Table 3-4 and Table 3-5 .

3.16.4.14. SMC Master Attribute Register(Default Value: 0x00000000)

Offset: 0x48			Register Name: SMC_MST_ATTRI_REG
Bit	R/W	Default/Hex	Description
31:0	R/W	0x0	MST_ATTRI. 0: The secure attribute of master is up to master security extensions; 1: The secure attribute of master is up to SMC Master Secure Register .

3.16.4.15. DRM Master Enable Register(Default Value: 0x00000000)

Offset: 0x50			Register Name: DRM_MASTER_EN_REG
Bit	R/W	Default/Hex	Description
31	R/W	0x0	DRM_EN. DRM enable.
30:12	/	/	/
13	R/W	0x0	GPU_WRITE_EN GPU write enable.
12	R/W	0x0	GPU_READ_EN GPU read enable.
11	R/W	0x0	GPU_EN GPU enable When setted the bit to 1,bit12 and bit13 will be invalid.
10:9	/	/	/
8	R/W	0x0	DE_ROT DE_ROT enable
7	R/W	0x0	DE_INTERLACE DE_INTERLACE enable.
6	R/W	0x0	DE_RT-WB

			DE_RT-WB enable.
5	R/W	0x0	DE_RT-MIXER1 DE_RT-MIXER1 enable.
4	R/W	0x0	DE_RT-MIXER0 DE_RT-MIXER0 enable.
3:1	/	/	/
0	R/W	0x0	VE_DECODE_EN VE decode enable

3.16.4.16. DRM Illegal Access Register(Default Value: 0x00000000)

Offset: 0x58			Register Name: DRM_ILLACCE_REG0
Bit	R/W	Default/Hex	Description
31:0	RO	0x0	DRM_ILLACCE_REG. When a master, which is non-secure, accesses the DRM space, then the relevant bit will be set up. See Table 3-2 for detail.

3.16.4.17. DRM Start Address Register(Default Value: 0x00000000)

Offset: 0x60			Register Name: DRM_STATADDR_REG
Bit	R/W	Default/Hex	Description
31:15	R/W	0x0	DRM_STATADDR_REG.
14:0	/	/	/

3.16.4.18. DRM End Address Register(Default Value: 0x00000000)

Offset: 0x68			Register Name: DRM_ENDADDR_REG
Bit	R/W	Default/Hex	Description
31:15	R/W	0x0	DRM_ENDADDR_REG.
14:0	/	/	/

3.16.4.19. SMC Region Setup Low Register(Default Value: 0x00000000)

Offset: 0x100+N*0x10(N=0~15)			Register Name: SMC_REGION_SETUP_LO_REG
Bit	R/W	Default/Hex	Description
31:15	R/W	0x0	BASE_ADDRESS_LOW. Controls the base address [31:15] of region<n>. The SMC only permits a region to start at address 0x0, or at a multiple of its

			<p>region size. For example, if the size of a region is 512MB, and it is not at address 0x0, the only valid settings for this field are:</p> <p>17'b0010000000000000</p> <p>17'b0100000000000000</p> <p>17'b0110000000000000</p> <p>17'b1000000000000000</p> <p>17'b1010000000000000</p> <p>17'b1100000000000000</p> <p>17'b1110000000000000</p>
14:0	/	/	/

Note1:For region 0, this field is Read Only (RO). The SMC sets the base address of region 0 to 0x0.

Note2:The base address should be equal to the DRAM absolutely address.

3.16.4.20. SMC Region Setup High Register(Default Value: 0x00000000)

Offset: 0x104+N*0x10(N=0~15)			Register Name: SMC_REGION_SETUP_HI_REG
Bit	R/W	Default/Hex	Description
31:0	R/W	0x0	<p>BASE_ADDRESS_HIGH</p> <p>The SMC only permits a region to start at address 0x0, or at a multiple of its region size. If you program a region size to be 8GB or more, then the SMC might ignore certain bits depending on the region size.</p>

3.16.4.21. SMC Region Attributes Register(Default Value: 0x00000000)

Offset: 0x108+N*0x10(N=0~15)			Register Name: SMC_REGION_ATTR_REG
Bit	R/W	Default/Hex	Description
31:28	R/W	0x0	<p>REGION_ATTR_SPN.</p> <p>SP<n>. Permission setting for region <n>. if an AXI transaction occurs to region n, the value in the sp<n> field controls whether the SMC permits the transaction to proceed. . See Table 3-4 and Table 3-5.</p>
27:16	/	/	/.
15:8	R/W	0x0	<p>SUB_REGION_DISABLE.</p> <p>Subregion_disable. Regions are split into eight equal-sized sub-regions, and each bit enables the corresponding subregion to be disabled.</p> <p>Bit [15] = 1 subregion 7 is disabled.</p> <p>Bit [14] = 1 subregion 6 is disabled.</p> <p>Bit [13] = 1 subregion 5 is disabled.</p> <p>Bit [12] = 1 subregion 4 is disabled.</p> <p>Bit [11] = 1 subregion 3 is disabled.</p> <p>Bit [10] = 1 subregion 2 is disabled.</p> <p>Bit [9] = 1 subregion 1 is disabled.</p>

			Bit [8] = 1 subregion 0 is disabled.
7	/	/	/
6:1	R/W	0x0	REGION_ATTR_SIZE. Size<n>. Size of region<n>, see Table 3-3 for detail.
0	R/W	0x0	REGION_ATTR_EN. EN<n>. Enable for region<n>. 0 = region < n> is disabled. 1 = region < n> is enabled.

Note:For region 0,this field is reserved except SPN field.

3.17. Secure Peripherals Controller

3.17.1. Overview

Secure Peripherals Controller(SPC) provides a software interface to the protection bits in a secure system in a TrustZone design. It provides system flexibility that enables to configure different areas of memory as secure or non-secure.

The SPC includes the following features:

- It has protection bits to enable you to program some areas of memory as secure or non-secure.

3.17.2. Functionalities Description

3.17.2.1. Peripherals Security Feature Table

SPC contains secure peripherals,non-secure peripherals and switchable peripherals.Table 3-6 shows the security feature of A64 peripherals in CPUX and CPUS domain.

Table 3-6. Peripherals Security Feature Table

CPUX Domain			
Module Name	Security	Module Name	Security
SRAM A1	Switchable	DMA	Switchable/Trust Capabilities
DE-TOP	Switchable	CS DEBUG	Trust Capabilities
DE-MIXER0	Switchable	GIC	Trust Capabilities
DE-MIXER1	Switchable	MSG_BOX	Non-secure
DE-WB	Switchable	SPINLOCK	Non-secure
DE-ROT	Switchable	OWA	Non-secure
SMHC0	Switchable	PWM	Non-secure
SMHC1	Switchable	KEYADC	Non-secure
SMHC2	Switchable	I2S/PCM-0	Non-secure
System Control	Switchable	I2S/PCM-1	Non-secure
NAND	Switchable	I2S/PCM-2	Non-secure
CE	Switchable	Audio Codec	Non-secure
USB-OTG	Switchable	Thermal Sensor	Non-secure
USB-OTG-HCI	Switchable	EMAC	Non-secure
USB-HCIO	Switchable	GPU	Non-secure
CCU	Switchable	HSTIMER	Non-secure
GPIO	Switchable	MIPI DSI	Non-secure
TWIO	Switchable	CSI	Non-secure

TWI1	Switchable	HDMI	Non-secure
TWI2	Switchable	DE-interlace	Non-secure
DRAMC	Switchable	TS	Non-secure
SPI0	Switchable	TCON0	Non-secure
SPI1	Switchable	TCON1	Non-secure
VE SRAM	Switchable	VE	Non-secure
UART0	Switchable	TIMER	Non-secure
UART1	Switchable	SID	Secure
UART2	Switchable	SMC	Secure
UART3	Switchable	SPC	Secure
UART4	Switchable		
SCR	Switchable		
CPUX_CFG	Switchable		
DE-TOP	Switchable		

CPUS Domain			
Module Name	Security	Module Name	Security
PRCM	Switchable	R_UART	Switchable
R_CPUCFG	Switchable	R_CIR_RX	Switchable
R_INTC	Switchable	R_GPIO	Switchable
RTC	Switchable	R_RSB	Switchable
R_TIMER0	Switchable	R_PWM	Non-secure
R_TIMER1	Switchable	R_TWD	Secure
R_TIMER2	Switchable	R_WDOG	Secure
R_TIMER3	Switchable	SRAM A2	Secure
R_TWI	Switchable		

3.17.2.2. SPC Configuration Table

The table 3-7 shows the configuration region of the switchable peripherals.

Table 3-7. SPC Configuration Table

Bit	SPC0	SPC1	SPC2	SPC3	SPC4	SPC5
[0]	TWI0	NAND	VE SRAM	R_UART	UART0	DE-TOP
[1]	TWI1	DMA	R_CPUCFG	R_CIR_RX	UART1	DE-MIXER0
[2]	TWI2	Crypto Engine	System Control	R_GPIO	UART2	DE-MIXER1
[3]	SPI0	SRAM A1	CCU	R_RSB	UART3	DE-WB
[4]	SPI1	USB-OTG	USB HCl0	R_TIMER0	UART4	DE-ROT
[5]	GPIO	USB-OTG-HCI	RTC	R_TIMER1	SMHC0	
[6]	CPUX_CFG	DRAMC	R_INTC	R_TIMER2	SMHC1	
[7]	SCR	PRCM	R_TWI	R_TIMER3	SMHC2	

3.17.3. SPC Register List

Module Name	Base Address
SPC	0x01C23400

Register Name	Offset	Description
SPC_DECPOR0_STA_REG	0x4	SPC Decode Port0 Status Register
SPC_DECPOR0_SET_REG	0x8	SPC Decode Port0 Set Register
SPC_DECPOR0_CLR_REG	0xC	SPC Decode Port0 Clear Register
SPC_DECPOR1_STA_REG	0x10	SPC Decode Port1 Status Register
SPC_DECPOR1_SET_REG	0x14	SPC Decode Port1 Set Register
SPC_DECPOR1_CLR_REG	0x18	SPC Decode Port1 Clear Register
SPC_DECPOR2_STA_REG	0x1C	SPC Decode Port2 Status Register
SPC_DECPOR2_SET_REG	0x20	SPC Decode Port2 Set Register
SPC_DECPOR2_CLR_REG	0x24	SPC Decode Port2 Clear Register
SPC_DECPOR3_STA_REG	0x28	SPC Decode Port3 Status Register
SPC_DECPOR3_SET_REG	0x2C	SPC Decode Port3 Set Register
SPC_DECPOR3_CLR_REG	0x30	SPC Decode Port3 Clear Register
SPC_DECPOR4_STA_REG	0x34	SPC Decode Port4 Status Register
SPC_DECPOR4_SET_REG	0x38	SPC Decode Port4 Set Register
SPC_DECPOR4_CLR_REG	0x3C	SPC Decode Port4 Clear Register
SPC_DECPOR5_STA_REG	0x40	SPC Decode Port5 Status Register
SPC_DECPOR5_SET_REG	0x44	SPC Decode Port5 Set Register
SPC_DECPOR5_CLR_REG	0x48	SPC Decode Port5 Clear Register

3.17.4. SPC Register Description

3.17.4.1. SPC DECPOR0 Status Register(Default Value: 0x00000000)

Offset: 0x4			Register Name: SPC_DECPOR0_STA_REG
Bit	R/W	Default/Hex	Description
31:8	/	/	/
7:0	RO	0x0	<p>STA_DEC_PROTO_OUT.</p> <p>Show the status of the decode protection output:</p> <p>0: = Decode region corresponding to the bit is secure</p> <p>1: = Decode region corresponding to the bit is non-secure.</p> <p>There is one bit of the register for each protection output (See the SPC Configuration Table 3-7 in detail).</p>

3.17.4.2. SPC DECPORT0 Set Register(Default Value: 0x00000000)

Offset: 0x8			Register Name: SPC_DECPORT0_SET_REG
Bit	R/W	Default/Hex	Description
31:8	/	/	/.
7:0	WO	0x0	<p>SET_DEC_PORT0_OUT.</p> <p>Sets the corresponding decode protection output:</p> <p>0: = No effect</p> <p>1: = Set decode region to non-secure.</p> <p>There is one bit of the register for each protection output (See the SPC Configuration Table 3-7 in detail).</p>

3.17.4.3. SPC DECPORT0 Clear Register(Default Value: 0x00000000)

Offset: 0xC			Register Name: SPC_DECPORT0_CLR_REG
Bit	R/W	Default/Hex	Description
31:8	/	/	/
7:0	WO	0x0	<p>CLR_DEC_PROTO_OUT.</p> <p>Clears the corresponding decode protection output:</p> <p>0: = No effect</p> <p>1: = Set decode region to secure.</p> <p>There is one bit of the register for each protection output (See the SPC Configuration Table 3-7 in detail).</p>

3.17.4.4. SPC DECPORT1 Status Register(Default Value: 0x00000000)

Offset: 0x10			Register Name: SPC_DECPORT1_STA_REG
Bit	R/W	Default/Hex	Description
31:8	/	/	/
7:0	RO	0x0	<p>STA_DEC_PROT1_OUT.</p> <p>Show the status of the decode protection output:</p> <p>0: = Decode region corresponding to the bit is secure</p> <p>1: = Decode region corresponding to the bit is non-secure.</p> <p>There is one bit of the register for each protection output (See the SPC Configuration Table 3-7 in detail).</p>

3.17.4.5. SPC DECPORT1 Set Register(Default Value: 0x00000000)

Offset: 0x14			Register Name: SPC_DECPORT1_SET_REG
--------------	--	--	--

Bit	R/W	Default/Hex	Description
31:8	/	/	/
7:0	WO	0x0	SET_DEC_PORT1_OUT. Sets the corresponding decode protection output: 0: = No effect 1: = Set decode region to non-secure. There is one bit of the register for each protection output (See the SPC Configuration Table 3-7 in detail).

3.17.4.6. SPC DECPOR1 Clear Register(Default Value: 0x00000000)

Offset: 0x18			Register Name: SPC_DECPOR1_CLR_REG
Bit	R/W	Default/Hex	Description
31:8	/	/	/
7:0	WO	0x0	CLR_DEC_PROT1_OUT. Clears the corresponding decode protection output: 0: = No effect 1: = Set decode region to secure. There is one bit of the register for each protection output (See the SPC Configuration Table 3-7 in detail).

3.17.4.7. SPC DECPOR2 Status Register(Default Value: 0x00000000)

Offset: 0x1C			Register Name: SPC_DECPOR2_STA_REG
Bit	R/W	Default/Hex	Description
31:8	/	/	/
7:0	RO	0x0	STA_DEC_PROT2_OUT. Show the status of the decode protection output: 0: = Decode region corresponding to the bit is secure 1: = Decode region corresponding to the bit is non-secure. There is one bit of the register for each protection output (See the SPC Configuration Table 3-7 in detail).

3.17.4.8. SPC DECPOR2 Set Register(Default Value: 0x00000000)

Offset: 0x20			Register Name: SPC_DECPOR2_SET_REG
Bit	R/W	Default/Hex	Description
31:8	/	/	/
7:0	WO	0x0	SET_DEC_PORT2_OUT. Sets the corresponding decode protection output:

			<p>0: = No effect 1: = Set decode region to non-secure. There is one bit of the register for each protection output (See the SPC Configuration Table 3-7 in detail).</p>
--	--	--	--

3.17.4.9. SPC DECPOR2 Clear Register(Default Value: 0x00000000)

Offset: 0x24			Register Name: SPC_DECPOR2_CLR_REG
Bit	R/W	Default/Hex	Description
31:8	/	/	/
7:0	WO	0x0	<p>CLR_DEC_PROT2_OUT. Clears the corresponding decode protection output: 0: = No effect 1: = Set decode region to secure. There is one bit of the register for each protection output (See the SPC Configuration Table 3-7 in detail).</p>

3.17.4.10. SPC DECPOR3 Status Register(Default Value: 0x00000000)

Offset: 0x28			Register Name: SPC_DECPOR3_STA_REG
Bit	R/W	Default/Hex	Description
31:8	/	/	/
7:0	RO	0x0	<p>STA_DEC_PROT3_OUT. Show the status of the decode protection output: 0: = Decode region corresponding to the bit is secure 1: = Decode region corresponding to the bit is non-secure There is one bit of the register for each protection output (See the SPC Configuration Table 3-7 in detail).</p>

3.17.4.11. SPC DECPOR3 Set Register(Default Value: 0x00000000)

Offset: 0x2C			Register Name: SPC_DECPOR3_SET_REG
Bit	R/W	Default/Hex	Description
31:8	/	/	/
7:0	WO	0x0	<p>SET_DEC_PORT3_OUT. Sets the corresponding decode protection output: 0: = No effect 1: = Set decode region to non-secure There is one bit of the register for each protection output (See the SPC Configuration Table 3-7 in detail).</p>

3.17.4.12. SPC DECPOR3 Clear Register(Default Value: 0x00000000)

Offset: 0x30			Register Name: SPC_DECPOR3_CLR_REG
Bit	R/W	Default/Hex	Description
31:8	/	/	/
7:0	WO	0x0	CLR_DEC_PROT3_OUT. Clears the corresponding decode protection output: 0: = No effect 1: = Set decode region to secure There is one bit of the register for each protection output (See the SPC Configuration Table 3-7 in detail).

3.17.4.13. SPC DECPOR4 Status Register(Default Value: 0x00000000)

Offset: 0x34			Register Name: SPC_DECPOR4_STA_REG
Bit	R/W	Default/Hex	Description
31:8	/	/	/
7:0	RO	0x0	STA_DEC_PROT4_OUT. Show the status of the decode protection output: 0: = Decode region corresponding to the bit is secure 1: = Decode region corresponding to the bit is non-secure There is one bit of the register for each protection output (See the SPC Configuration Table 3-7 in detail).

3.17.4.14. SPC DECPOR4 Set Register(Default Value: 0x00000000)

Offset: 0x38			Register Name: SPC_DECPOR4_SET_REG
Bit	R/W	Default/Hex	Description
31:8	/	/	/
7:0	WO	0x0	SET_DEC_PORT4_OUT. Sets the corresponding decode protection output: 0: = No effect 1: = Set decode region to non-secure There is one bit of the register for each protection output (See the SPC Configuration Table 3-7 in detail).

3.17.4.15. SPC DECPOR4 Clear Register(Default Value: 0x00000000)

Offset: 0x3C			Register Name: SPC_DECPOR4_CLR_REG
--------------	--	--	---

Bit	R/W	Default/Hex	Description
31:8	/	/	/
7:0	WO	0x0	CLR_DEC_PROT4_OUT. Clears the corresponding decode protection output: 0: = No effect 1: = Set decode region to secure There is one bit of the register for each protection output (See the SPC Configuration Table 3-7 in detail).

3.17.4.16. SPC DECPOR5 Status Register(Default Value: 0x00000000)

Offset: 0x40			Register Name: SPC_DECPOR5_STA_REG
Bit	R/W	Default/Hex	Description
31:8	/	/	/
7:0	RO	0x0	STA_DEC_PROT5_OUT. Show the status of the decode protection output: 0: = Decode region corresponding to the bit is secure 1: = Decode region corresponding to the bit is non-secure There is one bit of the register for each protection output (See the SPC Configuration Table 3-7 in detail).

3.17.4.17. SPC DECPOR5 Set Register(Default Value: 0x00000000)

Offset: 0x44			Register Name: SPC_DECPOR5_SET_REG
Bit	R/W	Default/Hex	Description
31:8	/	/	/
7:0	WO	0x0	SET_DEC_PORT5_OUT. Sets the corresponding decode protection output: 0: = No effect 1: = Set decode region to non-secure There is one bit of the register for each protection output (See the SPC Configuration Table 3-7 in detail).

3.17.4.18. SPC DECPOR5 Clear Register(Default Value: 0x00000000)

Offset: 0x48			Register Name: SPC_DECPOR5_CLR_REG
Bit	R/W	Default/Hex	Description
31:8	/	/	/
7:0	WO	0x0	CLR_DEC_PROT5_OUT. Clears the corresponding decode protection output:

			<p>0: = No effect 1: = Set decode region to secure There is one bit of the register for each protection output (See the SPC Configuration Table 3-7 in detail).</p>
--	--	--	---

3.18. Thermal Sensor Controller

3.18.1. Overview

The thermal sensors have become common elements in wide range of modern system on chip (SOC) platform. Thermal sensors are used to constantly monitor the temperature on the chip.

A64 embeds three thermal sensors in possible hot spots on the die, sensor0 located in the CPU, sensor1 and sensor2 located in the GPU. The thermal sensor Generates interrupt to SW to lower temperature via DVFS, on reaching a certain thermal threshold.

The Thermal Sensor Controller includes the following features:

- Supports APB 32-bits bus width
- Power supply voltage:3.0V
- Low power dissipation
- Periodic temperature measurement
- Averaging filter for thermal sensor reading
- Support over-temperature protection interrupt and over-temperature alarm interrupt

3.18.2. Clock and Timing Requirements

CLK_IN = 24MHz/M, M can be set in the CCU

Conversion Time = $1/(24\text{MHz}/M/14\text{Cycles}) = 0.583 * M$ (us)

THERMAL_PER (configured by the value of THERMAL_PER) is must be greater than (ACQ1 + ACQ0+Conversion Time)

THERMAL_PER > ACQ1 + ACQ0+Conversion Time

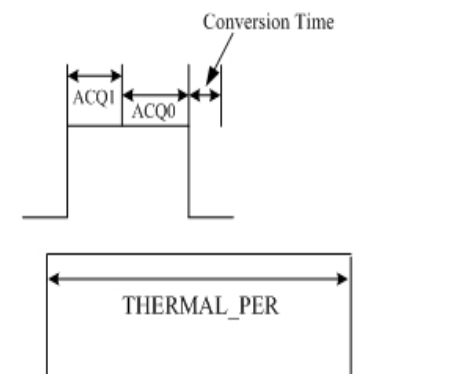

Figure 3-17. Thermal Conversion phase

3.18.3. Temperature Conversion Formula

$$\text{Temp} = -8.56 * \text{Data} + 2170 \text{ } ^\circ\text{C}$$

Val is the value that read from [THS0_DATA_REG/THS1_DATA_REG/THS2_DATA_REG](#).

3.18.4. Thermal Sensor Register List

Module Name	Base Address
Thermal Sensor	0x01C25000

Register Name	Offset	Description
THS_CTRL0	0x00	THS Control Register0
THS_CTRL1	0x04	THS Control Register1
ADC_CDAT	0x14	ADC calibration data Register
THS_CTRL2	0x40	THS Control Register2
THS_INT_CTRL	0x44	THS Interrupt Control Register
THS_STAT	0x48	THS Status Register
THS0_ALARM_CTRL	0x50	Alarm threshold Control Register0
THS1_ALARM_CTRL	0x54	Alarm threshold Control Register1
THS2_ALARM_CTRL	0x58	Alarm threshold Control Register2
THS0_SHUTDOWN_CTRL	0x60	Shutdown threshold Control Register0
THS1_SHUTDOWN_CTRL	0x64	Shutdown threshold Control Register1
THS2_SHUTDOWN_CTRL	0x68	Shutdown threshold Control Register2
THS_FILTER	0x70	Median filter Control Register
THS0_1_CDATA	0x74	Thermal Sensor 0 1 Calibration Data
THS2_CDATA	0x78	Thermal Sensor2 Calibration Data
THS0_DATA	0x80	THS0 Data Register
THS1_DATA	0x84	THS1 Data Register
THS2_DATA	0x88	THS2 Data Register

3.18.5. Thermal Sensor Register Description

3.18.5.1. THS Control Register0 (Default Value: 0x00000000)

Offset: 0x00			Register Name: THS_CTRL_REG0
Bit	R/W	Default/Hex	Description
31:16	/	/	/
15:0	R/W	0x0	SENSOR_ACQ0

			ADC acquire time CLK_IN/(N+1)
--	--	--	----------------------------------

3.18.5.2. THS Control Register1 (Default Value: 0x00000000)

Offset: 0x04			Register Name: THS_CTRL_REG1
Bit	R/W	Default/Hex	Description
31:22	/	/	/
21:20	R/W	0x0	THS_OP_BIAS. THS OP Bias
19:18	/	/	/
17	R/W	0x0	ADC_CALI_EN. ADC Calibration 1: start Calibration, it is clear to 0 after calibration
16:0	/	/	/

3.18.5.3. ADC calibration Data Register (Default Value: 0x00000000)

Offset: 0x14			Register Name: ADC_CDAT_REG
Bit	R/W	Default/Hex	Description
31:12	/	/	/
11:0	R/W	0xxxx	ADC_CDAT. ADC calibration data

3.18.5.4. THS Control Register2 (Default Value: 0x00040000)

Offset: 0x40			Register Name: THS_CTRL_REG2
Bit	R/W	Default/Hex	Description
31:16	R/W	0x4	SENSOR_ACQ1. Sensor acquire time CLK_IN/(N+1)
15:3	/	/	/
2	R/W	0x0	SENSE2_EN. Enable temperature measurement sensor2 0:Disable 1:Enable
1	R/W	0x0	SENSE1_EN. Enable temperature measurement sensor1 0:Disable 1:Enable

0	R/W	0x0	SENSE0_EN. Enable temperature measurement sensor0 0:Disable 1:Enable
---	-----	-----	---

3.18.5.5. THS Interrupt Control Register (Default Value: 0x00000000)

Offset: 0x44			Register Name: THS_INT_CTRL_REG
Bit	R/W	Default/Hex	Description
31:12	R/W	0x0	THERMAL_PER. 4096*(n+1)/CLK_IN
11	/	/	/
10	R/W	0x0	THS2_DATA_IRQ_EN. Selects Temperature measurement data of sensor2 0: No select 1: Select
9	R/W	0x0	THS1_DATA_IRQ_EN. Selects Temperature measurement data of sensor1 0: No select 1: Select
8	R/W	0x0	THS0_DATA_IRQ_EN. Selects Temperature measurement data of sensor0 0: No select 1: Select
7	/	/	/
6	R/W	0x0	SHUT_INT2_EN. Selects shutdown interrupt for sensor2 0: No select 1: Select
5	R/W	0x0	SHUT_INT1_EN. Selects shutdown interrupt for sensor1 0: No select 1: Select
4	R/W	0x0	SHUT_INT0_EN. Selects shutdown interrupt for sensor0 0: No select 1: Select
3	/	/	/
2	R/W	0x0	ALARM_INT2_EN. Selects Alert interrupt for sensor2 0: No select 1: Select

1	R/W	0x0	ALARM_INT1_EN. Selects Alert interrupt for sensor1 0: No select 1: Select
0	R/W	0x0	ALARM_INT0_EN. Selects Alert interrupt for sensor0 0: No select 1: Select

3.18.5.6. THS status Register (Default Value: 0x00000000)

Offset: 0x48			Register Name: THS_STAT_REG
Bit	R/W	Default/Hex	Description
31:15	/	/	/
14	R/W	0x0	ALARM_OFF2_STS. Alarm interrupt off pending for sensor2 Write '1' to clear this interrupt or automatic clear if interrupt condition fails
13	R/W	0x0	ALARM_OFF1_STS. Alarm interrupt off pending for sensor1 Write '1' to clear this interrupt or automatic clear if interrupt condition fails
12	R/W	0x0	ALARM_OFF0_STS. Alarm interrupt off pending for sensor0 Write '1' to clear this interrupt or automatic clear if interrupt condition fails
11	/	/	/
10	R/W	0x0	THS2_DATA_IRQ_STS. Data interrupt status for sensor2 Write '1' to clear this interrupt or automatic clear if interrupt condition fails
9	R/W	0x0	THS1_DATA_IRQ_STS. Data interrupt status for sensor1 Write '1' to clear this interrupt or automatic clear if interrupt condition fails
8	R/W	0x0	THS0_DATA_IRQ_STS. Data interrupt status for sensor0 Write '1' to clear this interrupt or automatic clear if interrupt condition fails
7	/	/	/
6	R/W	0x0	SHUT_INT2_STS. Shutdown interrupt status for sensor2 Write '1' to clear this interrupt or automatic clear if interrupt condition

			fails
5	R/W	0x0	SHUT_INT1_STS. Shutdown interrupt status for sensor1 Write '1' to clear this interrupt or automatic clear if interrupt condition fails
4	R/W	0x0	SHUT_INT0_STS. Shutdown interrupt status for sensor0 Write '1' to clear this interrupt or automatic clear if interrupt condition fails
3	/	/	/
2	R/W	0x0	ALARM_INT2_STS. Alarm interrupt pending for sensor2 Write '1' to clear this interrupt or automatic clear if interrupt condition fails
1	R/W	0x0	ALARM_INT1_STS. Alarm interrupt pending for sensor1 Write '1' to clear this interrupt or automatic clear if interrupt condition fails
0	R/W	0x0	ALARM_INT0_STS. Alarm interrupt pending for sensor0 Write '1' to clear this interrupt or automatic clear if interrupt condition fails

3.18.5.7. Alarm threshold Control Register0 (Default Value: 0x05a00684)

Offset: 0x50			Register Name: THS0_ALARM_CTRL_REG
Bit	R/W	Default/Hex	Description
31:28	/	/	/
27:16	R/W	0x5A0	ALARM0_T_HOT. Thermal sensor0 Alarm Threshold for hot temperature
15:12	/	/	/
11:0	R/W	0x684	ALARM0_T_HYST Thermal sensor0 Alarm threshold for hysteresis temperature

3.18.5.8. Alarm threshold Control Register1 (Default Value: 0x05a00684)

Offset: 0x54			Register Name: THS1_ALARM_CTRL_REG
Bit	R/W	Default/Hex	Description
31:28	/	/	/
27:16	R/W	0x5A0	ALARM1_T_HOT. Thermal sensor1 Alarm Threshold for hot temperature

15:12	/	/	/
11:0	R/W	0x684	ALARM1_T_HYST Thermal sensor1 Alarm threshold for hysteresis temperature

3.18.5.9. Alarm threshold Control Register2 (Default Value: 0x05a00684)

Offset: 0x58			Register Name: THS2_ALARM_CTRL_REG
Bit	R/W	Default/Hex	Description
31:28	/	/	/
27:16	R/W	0x5A0	ALARM2_T_HOT. Thermal sensor2 Alarm Threshold for hot temperature
15:12	/	/	/
11:0	R/W	0x684	ALARM2_T_HYST Thermal sensor2 Alarm threshold for hysteresis temperature

3.18.5.10. Shutdown threshold Control Register0 (Default Value: 0x04e90000)

Offset: 0x60			Register Name: THS0_SHUTDOWN_CTRL_REG
Bit	R/W	Default/Hex	Description
31:28	/	/	/
27:16	R/W	0x4E9	SHUT0_T_HOT. Thermal sensor0 Shutdown Threshold for hot temperature
15:0	/	/	/

3.18.5.11. Shutdown threshold Control Register1 (Default Value: 0x04e90000)

Offset: 0x64			Register Name: THS1_SHUTDOWN_CTRL_REG
Bit	R/W	Default/Hex	Description
31:28	/	/	/
27:16	R/W	0x4E9	SHUT1_T_HOT. Thermal sensor1 Shutdown Threshold for hot temperature
15:0	/	/	/

3.18.5.12. Shutdown threshold Control Register2 (Default Value: 0x04e90000)

Offset: 0x68			Register Name: THS2_SHUTDOWN_CTRL_REG
Bit	R/W	Default/Hex	Description
31:28	/	/	/

27:16	R/W	0x4E9	SHUT2_T_HOT. Thermal sensor2 Shutdown Threshold for hot temperature
15:0	/	/	/

3.18.5.13. Average filter Control Register (Default Value: 0x00000001)

Offset: 0x70			Register Name: THS_FILTER_REG
Bit	R/W	Default/Hex	Description
31:3	/	/	/
2	R/W	0x0	FILTER_EN. Filter Enable 0: Disable 1: Enable
1:0	R/W	0x1	FILTER_TYPE. Average Filter Type 00: 2 01: 4 10: 8 11: 16

3.18.5.14. Thermal Sensor 0&1 calibration Data Register (Default Value: 0x08000800)

Offset: 0x74			Register Name: THS0_1_CDATA_REG
Bit	R/W	Default/Hex	Description
31:28	/	/	/
27:16	R/W	0x800	THS1_CDATA. Thermal Sensor1 calibration data
15:12	/	/	/
11:0	R/W	0x800	THS0_CDATA. Thermal Sensor0 calibration data

3.18.5.15. Thermal Sensor 2 calibration Data Register (Default Value: 0x00000800)

Offset: 0x78			Register Name: THS2_CDATA_REG
Bit	R/W	Default/Hex	Description
31:12	/	/	/
11:0	R/W	0x800	THS2_CDATA. Thermal Sensor2 calibration data

3.18.5.16. THS0 Data Register (Default Value: 0x00000000)

Offset: 0x80			Register Name: THS0_DATA_REG
Bit	R/W	Default/Hex	Description
31:12	/	/	/
11:0	R	0x0	THS0_DATA. Temperature measurement data of sensor0

3.18.5.17. THS1 Data Register (Default Value: 0x00000000)

Offset: 0x84			Register Name: THS1_DATA_REG
Bit	R/W	Default/Hex	Description
31:12	/	/	/
11:0	R	0x0	THS1_DATA. Temperature measurement data of sensor1

3.18.5.18. THS2 Data Register (Default Value: 0x00000000)

Offset: 0x88			Register Name: THS2_DATA_REG
Bit	R/W	Default/Hex	Description
31:12	/	/	/
11:0	R	0x0	THS2_DATA. Temperature measurement data of sensor2

3.19. KEYADC

3.19.1. Overview

KEYADC is 6-bit resolution ADC for key application. The KEYADC can work up to 250Hz conversion rate.

The KEYADC includes the following features:

- Supports APB 32-bits bus width,reference voltage is 2.0V
- Support interrupt
- Support Hold Key and General Key
- Support Single Key and Continue Key mode
- Support 6-bits resolution
- Voltage input range between 0V to 2.0V
- Sample rate up to 250Hz

3.19.2. Clock Source

The following diagram shows the clock source of KEYADC.

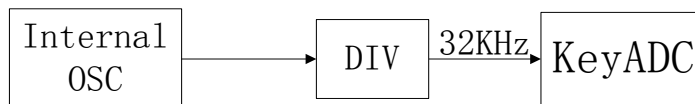

Figure 3-18. KEYADC Clock Source

3.19.3. Operation Principle

The KEYADC converted data can accessed by interrupt and polling method. If software can't access the last converted data instantly, the new converted data would update the old one at new sampling data.

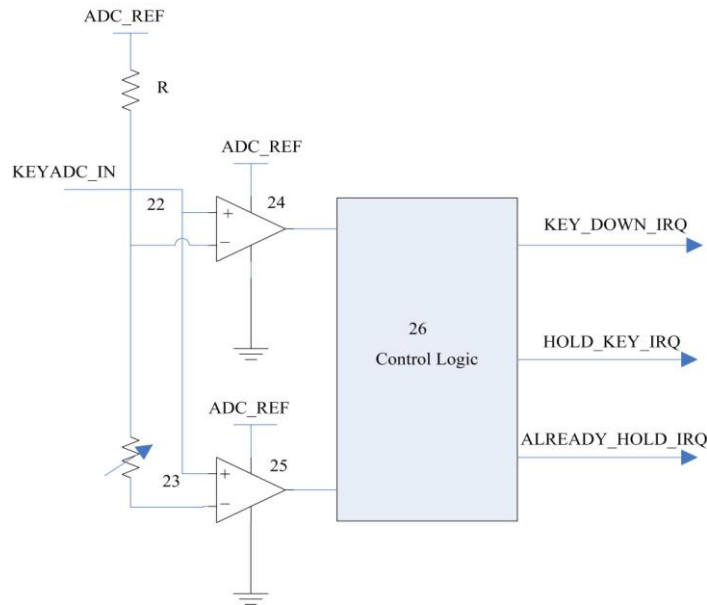

Figure 3-19. KEY_ADC Converted Data Diagram

When ADC_IN Signal change from 1.8V to less than 1.35V (Level A), the comparator24 send first interrupt to control logic; When ADC_IN Signal change from 1.35V to less than certain level (Program can set), the comparator25 give second interrupt. If the control Logic get the first interrupt, In a certain time range (program can set), doesn't get second interrupt, it will send hold key interrupt to the host; If the control Logic get the first interrupt, In a certain time range (program can set), get second interrupt, it will send key down interrupt to the host; If the control logic only get the second interrupt, doesn't get the first interrupt, it will send already hold interrupt to the host.

The KEYADC have three mode, **Normal Mode**、**Single Mode** and **Continue Mode**. **Normal Mode** is that the KEYADC will report the result data of each convert all the time when the key is down. **Single Mode** is that the KEYADC will only report the first convert result data when the key is down. **Continue Mode** is that the KEYADC will report one of $8*(N+1)$ (N is program can set) sample convert result data when key is down.

The KEYADC is support four sample rate such as 250Hz、125Hz、62.5Hz and 32.25Hz, you can configure the value of **KEYADC_SAMPLE_RATE** to select the fit sample rate.

3.19.4. KEY_ADC Register List

Module Name	Base Address
KEYADC	0x01C21800

Register Name	Offset	Description
KEYADC_CTRL	0x00	KEYADC Control Register
KEYADC_INTC	0x04	KEYADC Interrupt Control Register
KEYADC_INTS	0x08	KEYADC Interrupt Status Register

KEYADC_DATA	0x0C	KEYADC Data Register
-------------	------	----------------------

3.19.5. KEYADC Register Description

3.19.5.1. KEYADC Control Register (Default Value: 0x01000168)

Offset: 0x00			Register Name: KEYADC_CTRL_REG
Bit	R/W	Default/Hex	Description
31:24	R/W	0x1	FIRST_CONVERT_DLY. ADC First Convert Delay setting, ADC conversion is delayed by n samples
23:22	R/W	0x0	Reserved to 0
21:20	/	/	/
19:16	R/W	0x0	CONTINUE_TIME_SELECT. Continue Mode time select, one of 8*(N+1) sample as a valuable sample data
15:14	/	/	/
13:12	R/W	0x0	KEY_MODE_SELECT. Key Mode Select: 00: Normal Mode 01: Single Mode 10: Continue Mode
11:8	R/W	0x1	LEVELA_B_CNT. Level A to Level B time threshold select, judge ADC convert value in level A to level B in n+1 samples
7	R/W	0x0	KEYADC_HOLD_KEY_EN KEYADC Hold Key Enable 0: Disable 1: Enable
6	R/W	0x1	KEYADC_HOLD_EN. KEYADC Sample hold Enable 0: Disable 1: Enable
5:4	R/W	0x2	LEVELB_VOL. Level B Corresponding Data Value setting (the real voltage value) 00: 0x3C (~1.9v) 01: 0x39 (~1.8v) 10: 0x36 (~1.7v) 11: 0x33 (~1.6v)
3:2	R/W	0x2	KEYADC_SAMPLE_RATE. KEYADC Sample Rate 00: 250 Hz 01: 125 Hz

			10: 62.5 Hz 11: 32.25 Hz
1	/	/	/
0	R/W	0x0	KEYADC_EN. KEYADC enable 0: Disable 1: Enable

3.19.5.2. KEYADC Interrupt Control Register (Default Value: 0x00000000)

Offset: 0x04			Register Name: KEYADC_INTC_REG
Bit	R/W	Default/Hex	Description
31:5	/	/	/
4	R/W	0x0	ADC_KEYUP_IRQ_EN. ADC Key Up IRQ Enable 0: Disable 1: Enable
3	R/W	0x0	ADC_ALRDY_HOLD_IRQ_EN. ADC Already Hold IRQ Enable 0: Disable 1: Enable
2	R/W	0x0	ADC_HOLD_IRQ_EN. ADC Hold Key IRQ Enable 0: Disable 1: Enable
1	R/W	0x0	ADC_KEYDOWN_EN ADC Key Down Enable 0: Disable 1: Enable
0	R/W	0x0	ADC_DATA_IRQ_EN. ADC Data IRQ Enable 0: Disable 1: Enable

3.19.5.3. KEYADC Interrupt Status Register (Default Value: 0x00000000)

Offset: 0x08			Register Name: KEYADC_INTS_REG
Bit	R/W	Default/Hex	Description
31:5	/	/	/
4	R/W	0x0	ADC_KEYUP_PENDING. ADC Key up pending Bit

			<p>When general key pull up, it the corresponding interrupt is enabled.</p> <p>0: No IRQ 1: IRQ Pending</p> <p>Notes: Writing 1 to the bit will clear it and its corresponding interrupt if the interrupt is enable</p>
3	R/W	0x0	<p>ADC_ALRDY_HOLD_PENDING. ADC Already Hold Pending Bit</p> <p>When hold key pull down and pull the general key down, if the corresponding interrupt is enabled.</p> <p>0: No IRQ 1: IRQ Pending</p> <p>Notes: Writing 1 to the bit will clear it and its corresponding interrupt if the interrupt is enable</p>
2	R/W	0x0	<p>ADC_HOLDKEY_PENDING. ADC Hold Key pending Bit</p> <p>When Hold key pull down, the status bit is set and the interrupt line is set if the corresponding interrupt is enabled.</p> <p>0: NO IRQ 1: IRQ Pending</p> <p>Notes: Writing 1 to the bit will clear it and its corresponding interrupt if the interrupt is enable.</p>
1	R/W	0x0	<p>ADC_KEYDOWN_PENDING. ADC Key Down IRQ Pending Bit</p> <p>When General key pull down, the status bit is set and the interrupt line is set if the corresponding interrupt is enabled.</p> <p>0: No IRQ 1: IRQ Pending</p> <p>Notes: Writing 1 to the bit will clear it and its corresponding interrupt if the interrupt is enable.</p>
0	R/W	0x0	<p>ADC_DATA_PENDING. ADC Data IRQ Pending Bit</p> <p>0: No IRQ 1: IRQ Pending</p> <p>Notes: Writing 1 to the bit will clear it and its corresponding interrupt if the interrupt is enable.</p>

3.19.5.4. KEYADC Data Register (Default Value: 0x00000000)

Offset: 0x0C			Register Name: KEYADC_DATA_REG
Bit	R/W	Default/Hex	Description
31:6	/	/	/
5:0	R	0x0	KEYADC_DATA. KEYADC Data

3.20. Audio Codec

3.20.1. Overview

The Audio CODEC has two I2S/PCM interface, 2 channels DAC and 2 channels ADC with a high level of mixed-signal integration which ideal for smart phone and other portable devices. The two sets of audio interface pins are available in order to provide synchronous connections to multiple processors such as baseband processor and wireless headset transceiver.

The Codec integrates true-ground capless headphone driver to deliver high quality and power-efficient headphone playback without any requirement for DC block capacitors.

The integrated hardware DSP engine capable of AGC and DRC can be used in record and playback paths for maintaining a constant signal level,maximizing the loudness.

The features of Audio Codec:

- Two audio digital-to-analog(DAC) channels
- Stereo capless headphone drivers:
 - 100dB SNR@A-weight
 - Supports DAC Sample Rates from 8KHz to 192KHz
- Support analog/digital volume control
- Differential earpiece driver
- Analog low-power loop from line-in /microphone to headphone/earpiece outputs
- Support Dynamic Range Controller(DRC) adjusting the DAC playback output.
- Accessory button press detection
- Four audio inputs:
 - Two differential microphone inputs
 - One differential Phone input
 - Stereo Line-in L/R input
- Four audio outputs:
 - Earpiece amplifier differential output
 - Phone amplifier differential output
 - Headphone amplifier L/R channel output
 - Line-out L/R output
- Two audio analog-to-digital(ADC) channels
 - 96dB SNR@A-weight
 - Supports ADC Sample Rates from 8KHz to 48KHz
- Support Automatic Gain Control(AGC) and Dynamic Range Control(DRC) adjusting the ADC recording output
- Two PCM interface connected with BB and BT
- One 128x24-bits FIFO for data transmit, one 64x24-bits FIFO for data receive

- Programmable FIFO thresholds
- Interrupt and DMA Support
- Support Audio HUB

3.20.2. Power and Signal Description

3.20.2.1. Analog I/O Pins

MIC1P	I	Positive differential input for MIC1
MIC1N	I	Negative differential input for MIC1
MIC2P	I	Positive differential input for MIC2
MIC2N	I	Negative differential input for MIC2
LINEINL	I	Left single-end input for LINE-IN
LINEINR	I	Right single-end input for LINE-IN
PHONEINP	I	Positive differential input for Phone
PHONEINN	I	Negative differential input for Phone
HPOUTL	O	Headphone amplifier left channel output
HPOUTR	O	Headphone amplifier right channel output
LINEOUTL	O	Left single-end output for LINE-OUT
LINEOUTR	O	Right single-end output for LINE-OUT
EAROUTP	O	Earpiece amplifier positive differential output
EAROUTN	O	Earpiece amplifier negative differential output
PHONEOUTP	O	Positive differential output for Phone
PHONEOUTN	O	Negative differential output for Phone
MIC-DET	I	Headphone MIC Detect
HP-DET	I	Headphone Jack Detect

3.20.2.2. Filter/Reference

MBIAS	O	First bias voltage output for main microphone
HBIAS	O	Second bias voltage output for headset microphone
HP-FB	I	Pseudo differential headphone ground feedback
CPN	O	charge pump flying-back capacitor
CPP	O	charge pump flying-back capacitor
VRA1	O	internal reference voltage
VRA2	O	internal reference voltage
VRP	O	internal reference voltage

3.20.2.3. Power/Ground

AVCC	P	Analog power
AGND	G	Analog ground
CPVDD	P	Analog power for headphone charge pump
CPVEE	P	Charge pump negative voltage output
VEE	P	PA negative voltage input

3.20.3. Data Path Diagram

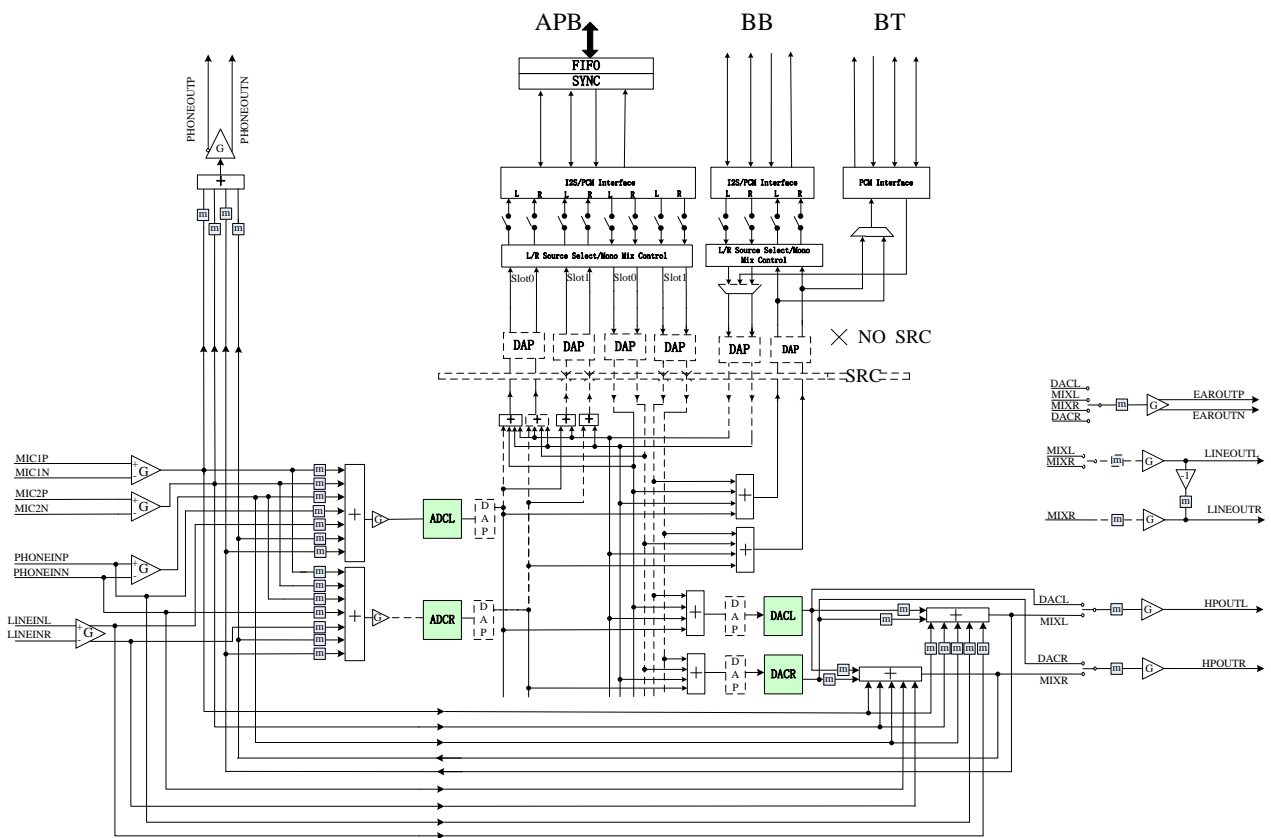

Figure 3-20. Audio Codec Data Path Diagram

3.20.4. Audio Codec Register List

Module Name	Base Address
AC	0X01C22C00

Register Name	Offset	Description
DA_CTL	0x000	Digital Audio Control Register
DA_FAT0	0x004	Digital Audio Format Register 0
DA_FAT1	0x008	Digital Audio Format Register 1
DA_ISTA	0x00C	Digital Audio Interrupt Status Register
DA_RXFIFO	0x010	Digital Audio RX FIFO Register
DA_FCTL	0x014	Digital Audio FIFO Control Register
DA_FSTA	0x018	Digital Audio FIFO Status Register
DA_INT	0x01C	Digital Audio Interrupt Control Register
DA_TXFIFO	0x020	Digital Audio TX FIFO Register
DA_CLKD	0x024	Digital Audio Clock Divide Register
DA_TXCNT	0x028	Digital Audio RX Sample Counter Register
DA_RXCNT	0x02C	Digital Audio TX Sample Counter Register
DA_TXCHSEL	0x030	Digital Audio TX Channel Select register
DA_TXCHMAP	0x034	Digital Audio TX Channel Mapping Register
DA_RXCHSEL	0x038	Digital Audio RX Channel Select register
DA_RXCHMAP	0x03C	Digital Audio RX Channel Mapping Register
Codec_RST	0x200	Chip Soft Reset Register
SYSCLK_CTL	0x20C	System Clock Control Register
MOD_CLK_ENA	0x210	Module Clock Control Register
MOD_RST_CTL	0x214	Module Reset Control Register
SYS_SR_CTRL	0x218	System Sample rate & SRC Configuration Register
SYS_SRC_CLK	0x21C	System SRC Clock Source Select Register
SYS_DVC_MOD	0x220	System DVC Mode Select Register
AIF1CLK_CTRL	0x240	AIF1 BCLK/LRCK Control Register
AIF1_ADCDAT_CTRL	0x244	AIF1 ADCDAT Control Register
AIF1_DACDAT_CTRL	0x248	AIF1 DACDAT Control Register
AIF1_MIXR_SRC	0x24C	AIF1 Digital Mixer Source Select Register
AIF1_VOL_CTRL1	0x250	AIF1 Volume Control 1 Register
AIF1_VOL_CTRL2	0x254	AIF1 Volume Control 2 Register
AIF1_VOL_CTRL3	0x258	AIF1 Volume Control 3 Register
AIF1_VOL_CTRL4	0x25C	AIF1 Volume Control 4 Register
AIF1_MXR_GAIN	0x260	AIF1 Digital Mixer Gain Control Register
AIF1_RXD_CTRL	0x264	AIF1 Receiver Data Discarding Control Register
AIF2_CLK_CTRL	0x280	AIF2 BCLK/LRCK Control Register
AIF2_ADCDAT_CTRL	0x284	AIF2 ADCDAT Control Register
AIF2_DACDAT_CTRL	0x288	AIF2 DACDAT Control Register
AIF2_MXR_SRC	0x28C	AIF2 Digital Mixer Source Select Register
AIF2_VOL_CTRL1	0x290	AIF2 Volume Control 1 Register
AIF2_VOL_CTRL2	0x298	AIF2 Volume Control 2 Register
AIF2_MXR_GAIN	0x2A0	AIF2 Digital Mixer Gain Control Register

AIF2_RXD_CTRL	0x2A4	AIF2 Receiver Data Discarding Control Register
AIF3_CLK_CTRL	0x2C0	AIF3 BCLK/LRCK Control Register
AIF3_ADCDAT_CTRL	0x2C4	AIF3 ADCDAT Control Register
AIF3_DACDAT_CTRL	0x2C8	AIF3 DACDAT Control Register
AIF3_SGP_CTRL	0x2CC	AIF3 Signal Path Control Register
AIF3_RXD_CTRL	0x2E4	AIF3 Receiver Data Discarding Control Register
ADC_DIG_CTRL	0x300	ADC Digital Control Register
ADC_VOL_CTRL	0x304	ADC Volume Control Register
ADC_DBG_CTRL	0x308	ADC Debug Control Register
HMIC_CTRL1	0x310	HMIC Control 1 Register
HMIC_CTRL2	0x314	HMIC Control 2 Register
HMIC_STS	0x318	HMIC Status Register
DAC_DIG_CTRL	0x320	DAC Digital Control Register
DAC_VOL_CTRL	0x324	DAC Volume Control Register
DAC_DBG_CTRL	0x328	DAC Debug Control Register
DAC_MXR_SRC	0x330	DAC Digital Mixer Source Select Register
DAC_MXR_GAIN	0x334	DAC Digital Mixer Gain Control Register
AC_ADC_DAPLSTA	0x400	ADC DAP Left Status Register
AC_ADC_DAPRSTA	0x404	ADC DAP Right Status Register
AC_ADC_DAPLCTRL	0x408	ADC DAP Left Channel Control Register
AC_ADC_DAPRCTRL	0x40C	ADC DAP Right Channel Control Register
AC_ADC_DAPLTL	0x410	ADC DAP Left Target Level Register
AC_ADC_DAPRTL	0x414	ADC DAP Right Target Level Register
AC_ADC_DAPLHAC	0x418	ADC DAP Left High Average Coef Register
AC_ADC_DAPLLAC	0x41C	ADC DAP Left Low Average Coef Register
AC_ADC_DAPRHAC	0x420	ADC DAP Right High Average Coef Register
AC_ADC_DAPRLAC	0x424	ADC DAP Right Low Average Coef Register
AC_ADC_DAPLDT	0x428	ADC DAP Left Decay Time Register
AC_ADC_DAPLAT	0x42C	ADC DAP Left Attack Time Register
AC_ADC_DAPRDT	0x430	ADC DAP Right Decay Time Register
AC_ADC_DAPRAT	0x434	ADC DAP Right Attack Time Register
AC_ADC_DAPNTH	0x438	ADC DAP Noise Threshold Register
AC_ADC_DAPLHNAC	0x43C	ADC DAP Left Input Signal High Average Coef Register
AC_ADC_DAPLLNAC	0x440	ADC DAP Left Input Signal Low Average Coef Register
AC_ADC_DAPRHNAC	0x444	ADC DAP Right Input Signal High Average Coef Register
AC_ADC_DAPRLNAC	0x448	ADC DAP Right Input Signal Low Average Coef Register
AC_DAPHPFC	0x44C	ADC DAP High HPF Coef Register
AC_DAPLHPFC	0x450	ADC DAP Low HPF Coef Register
AC_DAPOPT	0x454	ADC DAP Optimum Register

AC_DAC_DAPCTRL	0x480	DAC DAP Control Register
AGC_ENA	0x4D0	AGC Enable Register
DRC_ENA	0x4D4	DRC Enable Register
SRC_BISTCR	0x4D8	SRC Bist control Register
SRC_BISTST	0x4DC	SRC Bist Status Register
SRC1_CTRL1	0x4E0	SRC1 Control 1 Register
SRC1_CTRL2	0x4E4	SRC1 Control 2 Register
SRC1_CTRL3	0x4E8	SRC1 Control 3 Register
SRC1_CTRL4	0x4EC	SRC1 Control 4 Register
SRC2_CTRL1	0x4F0	SRC2 Control 1 Register
SRC2_CTRL2	0x4F4	SRC2 Control 2 Register
SRC2_CTRL3	0x4F8	SRC2 Control 3 Register
SRC2_CTRL4	0x4FC	SRC2 Control 4 Register
AC_DRC0_HHPFC	0x600	DRC0 High HPF Coef Register
AC_DRC0_LHPFC	0x604	DRC0 Low HPF Coef Register
AC_DRC0_CTRL	0x608	DRC0 Control Register
AC_DRC0_LPFHAT	0x60C	DRC0 Left Peak Filter High Attack Time Coef Register
AC_DRC0_LPFLAT	0x610	DRC0 Left Peak Filter Low Attack Time Coef Register
AC_DRC0_RPFHAT	0x614	DRC0 Right Peak Filter High Attack Time Coef Register
AC_DRC0_RPFLAT	0x618	DRC0 Peak Filter Low Attack Time Coef Register
AC_DRC0_LPFHRT	0x61C	DRC0 Left Peak Filter High Release Time Coef Register
AC_DRC0_LPFLRT	0x620	DRC0 Left Peak Filter Low Release Time Coef Register
AC_DRC0_RPFHRT	0x624	DRC0 Right Peak filter High Release Time Coef Register
AC_DRC0_RPFLRT	0x628	DRC0 Right Peak filter Low Release Time Coef Register
AC_DRC0_LRMSHAT	0x62C	DRC0 Left RMS Filter High Coef Register
AC_DRC0_LRMSLAT	0x630	DRC0 Left RMS Filter Low Coef Register
AC_DRC0_RRMSHAT	0x634	DRC0 Right RMS Filter High Coef Register
AC_DRC0_RRMSLAT	0x638	DRC0 Right RMS Filter Low Coef Register
AC_DRC0_HCT	0x63C	DRC0 Compressor Theshold High Setting Register
AC_DRC0_LCT	0x640	DRC0 Compressor Slope High Setting Register
AC_DRC0_HKC	0x644	DRC0 Compressor Slope High Setting Register
AC_DRC0_LKC	0x648	DRC0 Compressor Slope Low Setting Register
AC_DRC0_HOPC	0x64C	DRC0 Compressor High Output at Compressor Threshold Register
AC_DRC0_LOPC	0x650	DRC0 Compressor Low Output at Compressor Threshold Register
AC_DRC0_HLT	0x654	DRC0 Limiter Theshold High Setting Register
AC_DRC0_LLT	0x658	DRC0 Limiter Theshold Low Setting Register
AC_DRC0_HKI	0x65C	DRC0 Limiter Slope High Setting Register
AC_DRC0_LKI	0x660	DRC0 Limiter Slope Low Setting Register

AC_DRC0_HOPL	0x664	DRC0 Limiter High Output at Limiter Threshold
AC_DRC0_LOPL	0x668	DRC0 Limiter Low Output at Limiter Threshold
AC_DRC0_HET	0x66C	DRC0 Expander Theshold High Setting Register
AC_DRC0_LET	0x670	DRC0 Expander Theshold Low Setting Register
AC_DRC0_HKE	0x674	DRC0 Expander Slope High Setting Register
AC_DRC0_LKE	0x678	DRC0 Expander Slope Low Setting Register
AC_DRC0_HOPE	0x67C	DRC0 Expander High Output at Expander Threshold
AC_DRC0_LOPE	0x680	DRC0 Expander Low Output at Expander Threshold
AC_DRC0_HKN	0x684	DRC0 Linear Slope High Setting Register
AC_DRC0_LKN	0x688	DRC0 Linear Slope Low Setting Register
AC_DRC0_SFHAT	0x68C	DRC0 Smooth filter Gain High Attack Time Coef Register
AC_DRC0_SFLAT	0x690	DRC0 Smooth filter Gain Low Attack Time Coef Register
AC_DRC0_SFHRT	0x694	DRC0 Smooth filter Gain High Release Time Coef Register
AC_DRC0_SFLRT	0x698	DRC0 Smooth filter Gain Low Release Time Coef Register
AC_DRC0_MXGHS	0x69C	DRC0 MAX Gain High Setting Register
AC_DRC0_MXGLS	0x6A0	DRC0 MAX Gain Low Setting Register
AC_DRC0_MNGHS	0x6A4	DRC0 MIN Gain High Setting Register
AC_DRC0_MNGLS	0x6A8	DRC0 MIN Gain Low Setting Register
AC_DRC0_EPSHC	0x6AC	DRC0 Expander Smooth Time High Coef Register
AC_DRC0_EPSLC	0x6B0	DRC0 Expander Smooth Time Low Coef Register
AC_DRC0_OPT	0x6AC	DRC0 Optimum Register
AC_DRC1_HHPFC	0x700	DRC1 High HPF Coef Register
AC_DRC1_LHPFC	0x704	DRC1 Low HPF Coef Register
AC_DRC1_CTRL	0x708	DRC1 Control Register
AC_DRC1_LPFHAT	0x70C	DRC1 Left Peak Filter High Attack Time Coef Register
AC_DRC1_LPFLAT	0x710	DRC1 Left Peak Filter Low Attack Time Coef Register
AC_DRC1_RPFHAT	0x714	DRC1 Right Peak Filter High Attack Time Coef Register
AC_DRC1_RPFLAT	0x718	DRC1 Peak Filter Low Attack Time Coef Register
AC_DRC1_LPFHRT	0x71C	DRC1 Left Peak Filter High Release Time Coef Register
AC_DRC1_LPFLRT	0x720	DRC1 Left Peak Filter Low Release Time Coef Register
AC_DRC1_RPFHRT	0x724	DRC1 Right Peak filter High Release Time Coef Register
AC_DRC1_RPFLRT	0x728	DRC1 Right Peak filter Low Release Time Coef Register
AC_DRC1_LRMSHAT	0x72C	DRC1 Left RMS Filter High Coef Register
AC_DRC1_LRMSLAT	0x730	DRC1 Left RMS Filter Low Coef Register
AC_DRC1_RRMSHAT	0x734	DRC1 Right RMS Filter High Coef Register
AC_DRC1_RRMSLAT	0x738	DRC1 Right RMS Filter Low Coef Register
AC_DRC1_HCT	0x73C	DRC1 Compressor Theshold High Setting Register
AC_DRC1_LCT	0x740	DRC1 Compressor Slope High Setting Register
AC_DRC1_HKC	0x744	DRC1 Compressor Slope High Setting Register
AC_DRC1_LKC	0x748	DRC1 Compressor Slope Low Setting Register
AC_DRC1_HOPC	0x74C	DRC1 Compressor High Output at Compressor Threshold

		Register
AC_DRC1_LOPC	0x750	DRC1 Compressor Low Output at Compressor Threshold Register
AC_DRC1_HLT	0x754	DRC1 Limiter Theshold High Setting Register
AC_DRC1_LLT	0x758	DRC1 Limiter Theshold Low Setting Register
AC_DRC1_HKI	0x75C	DRC1 Limiter Slope High Setting Register
AC_DRC1_LKI	0x760	DRC1 Limiter Slope Low Setting Register
AC_DRC1_HOPL	0x764	DRC1 Limiter High Output at Limiter Threshold
AC_DRC1_LOPL	0x768	DRC1 Limiter Low Output at Limiter Threshold
AC_DRC1_HET	0x76C	DRC1 Expander Theshold High Setting Register
AC_DRC1_LET	0x770	DRC1 Expander Theshold Low Setting Register
AC_DRC1_HKE	0x774	DRC1 Expander Slope High Setting Register
AC_DRC1_LKE	0x778	DRC1 Expander Slope Low Setting Register
AC_DRC1_HOPE	0x77C	DRC1 Expander High Output at Expander Threshold
AC_DRC1_LOPE	0x780	DRC1 Expander Low Output at Expander Threshold
AC_DRC1_HKN	0x784	DRC1 Linear Slope High Setting Register
AC_DRC1_LKN	0x788	DRC1 Linear Slope Low Setting Register
AC_DRC1_SFHAT	0x78C	DRC1 Smooth filter Gain High Attack Time Coef Register
AC_DRC1_SFLAT	0x790	DRC1 Smooth filter Gain Low Attack Time Coef Register
AC_DRC1_SFHRT	0x794	DRC1 Smooth filter Gain High Release Time Coef Register
AC_DRC1_SFLRT	0x798	DRC1 Smooth filter Gain Low Release Time Coef Register
AC_DRC1_MXGHS	0x79C	DRC1 MAX Gain High Setting Register
AC_DRC1_MXGLS	0x7A0	DRC1 MAX Gain Low Setting Register
AC_DRC1_MNGHS	0x7A4	DRC1 MIN Gain High Setting Register
AC_DRC1_MNGLS	0x7A8	DRC1 MIN Gain Low Setting Register
AC_DRC1_EPSHC	0x7AC	DRC1 Expander Smooth Time High Coef Register
AC_DRC1_EPSLC	0x7B0	DRC1 Expander Smooth Time Low Coef Register
AC_DRC1_OPT	0x7B4	DRC1 Optimum Register
Analog Domain Register		
HP_CTRL	0x00	Headphone Amplifier Control Register
OL_MIX_CTRL	0x01	Output Left Mixer Control Register
OR_MIX_CTRL	0x02	Output Right Mixer Control Register
EARPIECE_CTRL0	0x03	Earpiece Control Register 0
EARPIECE_CTRL1	0x04	Earpiece Control Register 1
LINEOUT_CTRL0	0x05	LINEOUT Control Register 0
LINEOUT_CTRL1	0x06	LINEOUT Control Register 1
MIC1_CTRL	0x07	MIC1 Control Register
MIC2_CTRL	0x08	MIC2 Control Register
LINEIN_CTRL	0x09	Linein Control Register
MIX_DAC_CTRL	0x0A	Mixer and DAC Control Register
L_ADCMIX_SRC	0x0B	Left ADC Mixer Control Register
R_ADCMIX_SRC	0x0C	Right ADC Mixer Control Register

ADC_CTRL	0x0D	ADC Control Register
HS_MBIAS_CTRL	0x0E	Headset Microphone Bias Control Register
APT_REG	0x0F	Analog Performance Tuning Register
OP_BIAS_CTRL0	0x10	OP BIAS Control Register 0
OP_BIAS_CTRL1	0x11	OP BIAS Control Register 1
ZC_VOL_CTRL	0x12	USB Bias & Volume Change Control Register
BIAS_CAL_DATA	0x13	Bias Calibration Data Register
BIAS_CAL_SET	0x14	Bias Calibration Set Data Register
BD_CAL_CTRL	0x15	Bias & DA16 Calibration Control Register
HP_PA_CTRL	0x16	Headphone PA Control Register
HP_CAL_CTRL	0x17	Headphone Calibration Control
RHP_CAL_DAT	0x18	Right Headphone Calibration DATE
RHP_CAL_SET	0x19	Right Headphone Calibration Setting
LHP_CAL_DAT	0x1A	Left Headphone Calibration DATE
LHP_CAL_SET	0x1B	Left Headphone Calibration Setting
MDET_CTRL	0x1C	Mic detect Control Register
JM_DET_CTRL	0x1D	Jack & Mic detect Control Register
PHOUT_CTRL	0x1E	Phone output Register
PHIN_CTRL	0x1F	Phone input Register

3.20.5. Audio Codec Register Description

3.20.5.1. 0x00 I2S_AP Control Register(Default Value: 0x00000000)

Offset: 0x00			Register Name: DA_CTL
Bit	R/W	Default/Hex	Description
31:9	/	/	/
8	R/W	0	SDO_EN 0: Disable 1: Enable
7	/	/	/
6	R/W	0	ASS Audio sample select when TX FIFO under run 0: Sending zero 1: Sending last audio sample
5	R/W	0	MS Master Slave Select 0: Master 1: Slave
4	R/W	0	PCM 0: I2S Interface

			1: PCM Interface
3	R/W	0	<p>LOOP</p> <p>Loop back test</p> <p>0: Normal mode</p> <p>1: Loop back test</p> <p>When set '1', connecting the SDO with the SDI in Master mode.</p>
2	R/W	0	<p>TXEN</p> <p>Transmitter Block Enable</p> <p>0: Disable</p> <p>1: Enable</p>
1	R/W	0	<p>RXEN</p> <p>Receiver Block Enable</p> <p>0: Disable</p> <p>1: Enable</p>
0	R/W	0	<p>GEN</p> <p>Globe Enable</p> <p>A disable on this bit overrides any other block or channel enables and flushes all FIFOs.</p> <p>0: Disable</p> <p>1: Enable</p>

3.20.5.2. 0x04 I2S_AP Format Register0(Default Value: 0x0000000C)

Offset: 0x04			Register Name: DA_FAT0
Bit	R/W	Default/Hex	Description
31:8	/	/	/
7	R/W	0	<p>LRCP</p> <p>Left/ Right Clock Parity</p> <p>0: Normal</p> <p>1: Inverted</p> <p>In DSP/ PCM mode</p> <p>0: MSB is available on 2nd BCLK rising edge after LRC rising edge</p> <p>1: MSB is available on 1st BCLK rising edge after LRC rising edge</p>
6	R/W	0	<p>BCP</p> <p>BCLK Parity</p> <p>0: Normal</p> <p>1: Inverted</p>
5:4	R/W	0	<p>SR</p> <p>Sample Resolution</p> <p>00: 16-bits</p> <p>01: 20-bits</p> <p>10: 24-bits</p> <p>11: Reserved</p>

3:2	R/W	0x3	WSS Word Select Size 00: 16 BCLK 01: 20 BCLK 10: 24 BCLK 11: 32 BCLK
1:0	R/W	0	FMT Serial Data Format 00: Standard I2S Format 01: Left Justified Format 10: Right Justified Format 11: Reserved

3.20.5.3. 0x08 I2S_AP Format Register1(Default Value: 0x00004020)

Offset: 0x08			Register Name: DA_FAT1
Bit	R/W	Default/Hex	Description
31:15	/	/	/
14:12	R/W	0x4	PCM_SYNC_PERIOD PCM SYNC Period Clock Number 000: 16 BCLK period 001: 32 BCLK period 010: 64 BCLK period 011: 128 BCLK period 100: 256 BCLK period Others : Reserved
11	R/W	0	PCM_SYNC_OUT PCM Sync Out 0: Enable PCM_SYNC output in Master mode 1: Suppress PCM_SYNC whilst keeping PCM_CLK running. Some Codec utilize this to enter a low power state.
10	R/W	0	PCM Out Mute Write 1 force PCM_OUT to 0
9	R/W	0	MLS MSB / LSB First Select 0: MSB First 1: LSB First
8	R/W	0	SEXT Sign Extend (only for 16 bits slot) 0: Zeros or audio gain padding at LSB position 1: Sign extension at MSB position When writing the bit is 0, the unused bits are audio gain for 13-bit linear sample and zeros padding for 8-bit companding sample.

			When writing the bit is 1, the unused bits are both sign extension.
7:6	R/W	0	SI Slot Index 00: the 1st slot 01: the 2nd slot 10: the 3rd slot 11: the 4th slot
5	R/W	1	SW Slot Width 0: 8 clocks width 1: 16 clocks width Notes: For A-law or u-law PCM sample, if this bit is set to 1, eight zero bits are following with PCM sample.
4	R/W	0	SSYNC Short Sync Select 0: Long Frame Sync 1: Short Frame Sync It should be set '1' for 8 clocks width slot.
3:2	R/W	0	RX_PDM PCM Data Mode 00: 16-bits Linear PCM 01: 8-bits Linear PCM 10: 8-bits u-law 11: 8-bits A-law
1:0	R/W	0	TX_PDM PCM Data Mode 00: 16-bits Linear PCM 01: 8-bits Linear PCM 10: 8-bits u-law 11: 8-bits A-law

3.20.5.4. 0x0C I2S_AP Interrupt Status Register(Default Value: 0x00000010)

Offset: 0x0C			Register Name: DA_ISTA
Bit	R/W	Default/Hex	Description
31:7	/	/	/
6	R/W	0	TXU_INT TX FIFO Under run Pending Interrupt 0: No Pending Interrupt 1: FIFO Under run Pending Interrupt
5	R/W	0	TXO_INT TX FIFO Overrun Pending Interrupt 0: No Pending Interrupt

			1: FIFO Overrun Pending Interrupt Write '1' to clear this interrupt
4	R/W	1	TXE_INT TX FIFO Empty Pending Interrupt 0: No Pending IRQ 1: FIFO Empty Pending Interrupt Write '1' to clear this interrupt or automatic clear if interrupt condition fails.
3:2	/	/	/
2	R/W	0	R XU_INT RX FIFO Under run Pending Interrupt 0: No Pending Interrupt 1:FIFO Under run Pending Interrupt Write 1 to clear this interrupt
1	R/W	0	R XO_INT RX FIFO Overrun Pending Interrupt 0: No Pending IRQ 1: FIFO Overrun Pending IRQ Write '1' to clear this interrupt
0	R/W	0	R XA_INT RX FIFO Data Available Pending Interrupt 0: No Pending IRQ 1: Data Available Pending IRQ Write '1' to clear this interrupt or automatic clear if interrupt condition fails.

3.20.5.5. 0x10 I2S_AP RX FIFO Register(Default Value: 0x00000000)

Offset: 0x10			Register Name: DA_RXFIFO
Bit	R/W	Default/Hex	Description
31:0	R	0	RX_DATA RX Sample Host can get one sample by reading this register. The left channel sample data is first and then the right channel sample.

3.20.5.6. 0x14 I2S_AP FIFO Control Register(Default Value: 0x000400F0)

Offset: 0x14			Register Name: DA_FCTL
Bit	R/W	Default/Hex	Description
31	R/W	0	HUB_EN Audio Hub Enable

			0: Disable 1: Enable
30:26	/	/	/
25	R/W	0	FTX Write '1' to flush TX FIFO, self clear to '0'.
24	R/W	0	FRX Write '1' to flush RX FIFO, self clear to '0'.
23:19	/	/	/
18:12	R/W	0x40	TXTL TX FIFO Empty Trigger Level Interrupt and DMA request trigger level for TXFIFO normal condition Trigger Level = TXTL
11:10	/	/	/
9:4	R/W	0xF	RXTL RX FIFO Trigger Level Interrupt and DMA request trigger level for RXFIFO normal condition Trigger Level = RXTL + 1
3	/	/	/
2	R/W	0	TXIM TX FIFO Input Mode (Mode 0, 1) 0: Valid data at the MSB of TXFIFO register 1: Valid data at the LSB of TXFIFO register Example for 20-bits transmitted audio sample: Mode 0: FIFO_I[23:0] = {TXFIFO[31:12], 4'h0} Mode 1: FIFO_I[23:0] = {TXFIFO[19:0], 4'h0}
1:0	R/W	0	RXOM RX FIFO Output Mode (Mode 0, 1, 2, 3) 00: Expanding '0' at LSB of DA_RXFIFO register. 01: Expanding received sample sign bit at MSB of DA_RXFIFO register. 10: Truncating received samples at high half-word of DA_RXFIFO register and low half-word of DA_RXFIFO register is filled by '0'. 11: Truncating received samples at low half-word of DA_RXFIFO register and high half-word of DA_RXFIFO register is expanded by its sign bit. Example for 20-bits received audio sample: Mode 0: RXFIFO[31:0] = {FIFO_O[19:0], 12'h0} Mode 1: RXFIFO[31:0] = {12{FIFO_O[19]}, FIFO_O[19:0]} Mode 2: RXFIFO[31:0] = {FIFO_O[19:4], 16'h0} Mode 3: RXFIFO[31:0] = {16{FIFO_O[19]}, FIFO_O[19:4]}

3.20.5.7. 0x18 I2S_AP FIFO Status Register(Default Value: 0x10800000)

Offset: 0x18			Register Name: DA_FSTA
Bit	R/W	Default/Hex	Description

31:29	/	/	/
28	R	1	TXE TX FIFO Empty 0: No room for new sample in TX FIFO 1: More than one room for new sample in TX FIFO (>= 1 word)
27:24	/	/	/
23:16	R	0x80	TXE_CNT TX FIFO Empty Space Word Counter
15:9	/	/	/
8	R	0	RXA RX FIFO Available 0: No available data in RX FIFO 1: More than one sample in RX FIFO (>= 1 word)
7	/	/	/
6:0	R	0	RXA_CNT RX FIFO Available Sample Word Counter

3.20.5.8. 0x1C I2S_AP DMA&Interrupt Control Register(Default Value: 0x00000000)

Offset: 0x1C			Register Name: DA_INT
Bit	R/W	Default/Hex	Description
31:8	/	/	/
7	R/W	0	TX_DRQ TX FIFO Empty DRQ Enable 0: Disable 1: Enable
6	R/W	0	TXUI_EN TX FIFO Under run Interrupt Enable 0: Disable 1: Enable
5	R/W	0	TXOI_EN TX FIFO Overrun Interrupt Enable 0: Disable 1: Enable When set to '1', an interrupt happens when writing new audio data if TX FIFO is full.
4	R/W	0	TXEI_EN TX FIFO Empty Interrupt Enable 0: Disable 1: Enable
3	R/W	0	RX_DRQ RX FIFO Data Available DRQ Enable

			0: Disable 1: Enable When set to '1', RXFIFO DMA Request line is asserted if Data is available in RX FIFO.
2	R/W	0	RXUI_EN RX FIFO Under run Interrupt Enable 0: Disable 1: Enable
1	R/W	0	RXOI_EN RX FIFO Overrun Interrupt Enable 0: Disable 1: Enable
0	R/W	0	RXAI_EN RX FIFO Data Available Interrupt Enable 0: Disable 1: Enable

3.20.5.9. 0x20 I2S_AP TX FIFO Register(Default Value: 0x00000000)

Offset: 0x20			Register Name: DA_TXFIFO
Bit	R/W	Default/Hex	Description
31:0	W	0X0	TX_DATA Transmitting left, right channel sample data should be written this register one by one. The left channel sample data is first and then the right channel sample.

3.20.5.10. 0x24 I2S_AP Clock Divide Register(Default Value: 0x00000000)

Offset: 0x24			Register Name: DA_CLKD
Bit	R/W	Default/Hex	Description
31:8	/	/	/
7	R/W	0	MCLKO_EN 0: Disable MCLK Output 1: Enable MCLK Output Notes: Whether in Slave or Master mode, when this bit is set to 1, MCLK should be output.
6:4	R/W	0	BCLKDIV BCLK Divide Ratio from MCLK 000: Divide by 2 (BCLK = MCLK/2) 001: Divide by 4 010: Divide by 6

			011: Divide by 8 100: Divide by 12 101: Divide by 16 110: Divide by 32 111: Divide by 64
3:0	R/W	0	MCLKDIV MCLK Divide Ratio from Audio PLL Output 0000: Divide by 1 0001: Divide by 2 0010: Divide by 4 0011: Divide by 6 0100: Divide by 8 0101: Divide by 12 0110: Divide by 16 0111: Divide by 24 1000: Divide by 32 1001: Divide by 48 1010: Divide by 64 Others : Reserved

3.20.5.11. 0x28 I2S_AP TX Counter Register(Default Value: 0x00000000)

Offset: 0x28			Register Name: DA_TXCNT
Bit	R/W	Default/Hex	Description
31:0	R/W	0	TX_CNT TX Sample Counter The audio sample number of sending into TXFIFO. When one sample is put into TXFIFO by DMA or by host IO, the TX sample counter register increases by one. The TX sample counter register can be set to any initial value at any time. After been updated by the initial value, the counter register should count on base of this initial value.

3.20.5.12. 0x2C I2S_AP RX Counter Register(Default Value: 0x00000000)

Offset: 0x2C			Register Name: DA_RXCNT
Bit	R/W	Default/Hex	Description
31:0	R/W	0	RX_CNT RX Sample Counter The audio sample number of writing into RXFIFO. When one sample is written by I2S_AP Engine, the RX sample counter register increases by one. The RX sample counter register can be set to any initial value at any

			time. After been updated by the initial value, the counter register should count on base of this initial value.
--	--	--	---

3.20.5.13. 0x30 I2S_AP TX Channel Select Register(Default Value: 0x00000001)

Offset: 0x30			Register Name: DA_TXCHSEL
Bit	R/W	Default/Hex	Description
31:3	/	/	/
2:0	R/W	1	TX_CHSEL TX Channel Select 0: 1-ch 1: 2-ch 2: 3-ch 3: 4-ch

3.20.5.14. 0x34 I2S_AP TX Channel Mapping Register(Default Value: 0x76543210)

Offset: 0x34			Register Name: DA_TXCHMAP
Bit	R/W	Default/Hex	Description
31:15	/	/	/
14:12	R/W	3	TX_CH3_MAP TX Channel3 Mapping 000: 1 st sample 001: 2 nd sample 010: 3 rd sample 011: 4 th sample 1xx: Reserved
11	/	/	/
10:8	R/W	2	TX_CH2_MAP TX Channel2 Mapping 000: 1 st sample 001: 2 nd sample 010: 3 rd sample 011: 4 th sample 1xx: Reserved
7	/	/	/
6:4	R/W	1	TX_CH1_MAP TX Channel1 Mapping 000: 1 st sample 001: 2 nd sample 010: 3 rd sample

			011: 4 th sample 1xx: Reserved
3	/	/	/
2:0	R/W	0	TX_CH0_MAP TX Channel0 Mapping 000: 1 st sample 001: 2 nd sample 010: 3 rd sample 011: 4 th sample 1xx: Reserved

3.20.5.15. 0x38 I2S_AP RX Channel Select Register(Default Value: 0x00000001)

Offset: 0x38			Register Name: DA_RXCHSEL
Bit	R/W	Default/Hex	Description
31:3	/	/	/
			RX_CHSEL RX Channel Select 0: 1-ch 1: 2-ch 2: 3-ch 3: 4-ch
2:0	R/W	1	Others: Reserved

3.20.5.16. 0x3C I2S_AP RX Channel Mapping Register(Default Value: 0x00003210)

Offset: 0x3C			Register Name: DA_RXCHMAP
Bit	R/W	Default/Hex	Description
31:15	/	/	/
14:12	R/W	3	RX_CH3_MAP RX Channel3 Mapping 000: 1 st sample 001: 2 nd sample 010: 3 rd sample 011: 4 th sample 1xx: Reserved
11	/	/	/
10:8	R/W	2	RX_CH2_MAP RX Channel2 Mapping 000: 1 st sample 001: 2 nd sample

			010: 3 rd sample 011: 4 th sample 1xx: Reserved
7	/	/	/
6:4	R/W	1	RX_CH1_MAP RX Channel1 Mapping 000: 1 st sample 001: 2 nd sample 010: 3 rd sample 011: 4 th sample 1xx: Reserved
3	/	/	/
2:0	R/W	0	RX_CH0_MAP RX Channel0 Mapping 000: 1 st sample 001: 2 nd sample 010: 3 rd sample 011: 4 th sample 1xx: Reserved

3.20.5.17. 0x200 Codec Reset Register(Default Value: 0x0000101)

Offset: 0x200			Register Name: Codec_RST
Bit	R/W	Default/Hex	Description
31:16	/	/	/
15:0	R/W	/	Reserved

3.20.5.18. 0x20C System Clock Control Register(Default Value: 0x00000000)

Offset: 0x20C			Register Name: SYSCLK_CTL
Bit	R/W	Default/Hex	Description
31:12	/	/	/
11	R/W	0x0	AIF1CLK_ENA AIF1CLK Enable 0: Disable 1: Enable
10	R/W	0x0	Reserved
9:8	R/W	0x0	AIF1CLK_SRC AIF1CLK Source Select 00: MLCK1 01: Reserved

			1X: pll2_1x
7	R/W	0x0	AIF2CLK_ENA AIF2CLK Enable 0: Disable 1: Enable
6	R/W	0x0	Reserved
5:4	R/W	0x0	AIF2CLK_SRC AIF2CLK Source Select 00: MLCK1 01: Reserved 1X: pll2_1x
3	R/W	0x0	SYSCLK_ENA SYSCLK Enable 0: Disable 1: Enable
2:1	R/W	0x0	Reserved
0	R/W	0x0	SYSCLK_SRC System Clock Source Select 0: AIF1CLK 1: AIF2CLK

3.20.5.19. 0x210 Module Clock Control Register(Default Value: 0x00000000)

Offset: 0x210			Register Name: MOD_CLK_ENA
Bit	R/W	Default/Hex	Description
31:16	R/W	0x0	Reserved
15:0	R/W	0x0000	Module clock enable control 0-Clock disable 1-Clock enable BIT15-AIF1 BIT14-AIF2 BIT13-AIF3 BIT12-Reserved BIT11-SRC1 BIT10-SRC2 BIT9-Reserved BIT8-Reserved BIT7-HPF & AGC BIT6-HPF & DRC0 BIT5-HPF & DRC1 BIT4-Reserved BIT3-ADC Digital BIT2-DAC Digital

			BIT1-Reserved BIT0-Reserved
--	--	--	--------------------------------

3.20.5.20. 0x214 Module Reset Control Register(Default Value: 0x00000000)

Offset: 0x214			Register Name: MOD_RST_CTL
Bit	R/W	Default/Hex	Description
31:16	R/W	0x0	Reserved
15:0	R/W	0x0000	Module reset control 0-Reset asserted 1-Reset de-asserted BIT15-AIF1 BIT14-AIF2 BIT13-AIF3 BIT12-Reserved BIT11-SRC1 BIT10-SRC2 BIT9-Reserved BIT8-Reserved BIT7-HPF & AGC BIT6-HPF & DRC0 BIT5-HPF & DRC1 BIT4-Reserved BIT3-ADC Digital BIT2-DAC Digital BIT1-Reserved BIT0-Reserved

3.20.5.21. 0x218 System Sample rate & SRC Configuration Register(Default Value: 0x00000000)

Offset: 0x218			Register Name: SYS_SR_CTRL
Bit	R/W	Default/Hex	Description
31:16	/	/	/
15:12	R/W	0x0	AIF1_FS AIF1 Sample Rate 0000: 8KHz 0001: 11.025KHz 0010: 12KHz 0011: 16KHz 0100: 22.05KHz 0101: 24KHz

			0110: 32KHz 0111: 44.1KHz 1000: 48KHz 1001: 96KHz 1010: 192KHz Other: Reserved
11:8	R/W	0x0	AIF2_FS AIF2 Sample Rate 0000: 8KHz 0001: 11.025KHz 0010: 12KHz 0011: 16KHz 0100: 22.05KHz 0101: 24KHz 0110: 32KHz 0111: 44.1KHz 1000: 48KHz 1001: 96KHz 1010: 192KHz Other: Reserved
3	R/W	0x0	SRC1_ENA SRC1 Enable. SRC1 Performs sample rate conversion of digital audio input to the codec. 0: Disable 1: Enable
2	R/W	0x0	SRC1_SRC From which the input data will come. 0: AIF1 DAC Timeslot 0 1: AIF2 DAC
1	R/W	0x0	SRC2_ENA SRC2 Enable. SRC2 Performs sample rate conversion of digital audio output from the codec. 0: Disable 1: Enable
0	R/W	0x0	SRC2_SRC To which the converted data will be output. 0: AIF1 ADC Timeslot 0 1: AIF2 ADC

3.20.5.22. 0x21C System SRC Clock Source Select Register(Default Value: 0x00000000)

Offset: 0x21C			Register Name: SYS_SRC_CLK
Bit	R/W	Default/Hex	Description

31:2	/	/	/
1:0	R/W	0x0	<p>SRC_CLK_SLT</p> <p>System SRC module output clock source select</p> <p>00: normal mode</p> <p>01: src1 output sample rate select DAC clk</p> <p>10: src2 input sample rate select ADC clk</p> <p>11: reserved</p>

3.20.5.23. 0x220 System DVC Mode Select Register(Default Value: 0x00000000)

Offset: 0x220			Register Name: SYS_DVC_CLK
Bit	R/W	Default/Hex	Description
31:2	/	/	/
1:0	R/W	0x0	<p>AIFDVC_FS_SEL</p> <p>0 : DVC output to AIF sync</p> <p>1 : normal</p>

3.20.5.24. 0x240 AIF1 BCLK/LRCK Control Register(Default Value: 0x00000000)

Offset: 0x240			Register Name: AIF1CLK_CTRL
Bit	R/W	Default/Hex	Description
15	R/W	0x0	<p>AIF1_MSTR_MOD</p> <p>AIF1 Audio Interface mode select</p> <p>0 = Master mode</p> <p>1 = Slave mode</p>
14	R/W	0x0	<p>AIF1_BCLK_INV</p> <p>AIF1 BCLK Polarity</p> <p>0: Normal</p> <p>1: Inverted</p>
13	R/W	0x0	<p>AIF1_LRCK_INV</p> <p>AIF1 LRCK Polarity</p> <p>0: Normal</p> <p>1: Inverted</p>
12:9	R/W	0x0	<p>AIF1_BCLK_DIV</p> <p>Select the AIF1CLK/BCLK1 ratio</p> <p>0000: AIF1CLK/1</p> <p>0001: AIF1CLK/2</p> <p>0010: AIF1CLK/4</p> <p>0011: AIF1CLK/6</p> <p>0100: AIF1CLK/8</p> <p>0101: AIF1CLK/12</p>

			0110: AIF1CLK/16 0111: AIF1CLK/24 1000: AIF1CLK/32 1001: AIF1CLK/48 1010: AIF1CLK/64 1011: AIF1CLK/96 1100: AIF1CLK/128 1101: AIF1CLK/192 1110: Reserved 1111: Reserved
8:6	R/W	0x0	AIF1_LRCK_DIV Select the BCLK1/LRCK ratio 000: 16 001: 32 010: 64 011: 128 100: 256 1xx: Reserved
5:4	R/W	0x0	AIF1_WORD_SIZ AIF1 digital interface word size 00: 8bit 01: 16bit 10: 20bit 11: 24bit
3:2	R/W	0x0	AIF1_DATA_FMT AIF1 digital interface data format 00: I2S mode 01: Left mode 10: Right mode 11: DSP mode
1	R/W	0x0	DSP_MONO_PCM DSP Mono mode select 0: Stereo mode select 1: Mono mode select
0	R/W	0x0	AIF1_TDMM_ENA AIF1 TDM Mode enable 0: Disable 1: Enable

3.20.5.25. 0x244 AIF1 ADCDAT Control Register(Default Value: 0x00000000)

Offset: 0x244			Register Name: AIF1_ADCDAT_CTRL
Bit	R/W	Default/Hex	Description

15	R/W	0x0	AIF1_ADC0L_ENA AIF1 ADC Timeslot 0 left channel enable 0: Disable 1: Enable
14	R/W	0x0	AIF1_ADC0R_ENA AIF1 ADC Timeslot 0 right channel enable 0: Disable 1: Enable
13	R/W	0x0	AIF1_ADC1L_ENA AIF1 ADC Timeslot 1 left channel enable 0: Disable 1: Enable
12	R/W	0x0	AIF1_ADC1R_ENA AIF1 ADC Timeslot 1 right channel enable 0: Disable 1: Enable
11:10	R/W	0x0	AIF1_ADC0L_SRC AIF1 ADC Timeslot 0 left channel data source select 00: AIF1 ADC0L 01: AIF1 ADC0R 10: (AIF1 ADC0L+AIF1 ADC0R) 11: (AIF1 ADC0L+AIF1 ADC0R)/2
9:8	R/W	0x0	AIF1_ADC0R_SRC AIF1 ADC Timeslot 0 right channel data source select 00: AIF1 ADC0R 01: AIF1 ADC0L 10: (AIF1 ADC0L+AIF1 ADC0R) 11: (AIF1 ADC0L+AIF1 ADC0R)/2
7:6	R/W	0x0	AIF1_ADC1L_SRC AIF1 ADC Timeslot 1 left channel data source select 00: AIF1 ADC1L 01: AIF1 ADC1R 10: (AIF1 ADC1L+AIF1 ADC1R) 11: (AIF1 ADC1L+AIF1 ADC1R)/2
5:4	R/W	0x0	AIF1_ADC1R_SRC AIF1 ADC Timeslot 1 right channel data source select 00: AIF1 ADC1R 01: AIF1 ADC1L 10: (AIF1 ADC1L+AIF1 ADC1R) 11: (AIF1 ADC1L+AIF1 ADC1R)/2
3	R/W	0x0	AIF1_ADCP_ENA AIF1 ADC Companding enable(8-bit mode only) 0: Disable 1: Enable

2	R/W	0x0	AIF1_ADCUL_ENA AIF1 ADC Companding mode select 0: A-law 1: u-law
1:0	R/W	0x0	AIF1_SLOT_SIZ Select the slot size(only in TDM mode) 00: 8 01: 16 10: 32 11: Reserved

3.20.5.26. 0x248 AIF1 DACDAT Control Register(Default Value: 0x00000000)

Offset: 0x248			Register Name: AIF1_DACDAT_CTRL
Bit	R/W	Default/Hex	Description
15	R/W	0x0	AIF1_DACOL_ENA AIF1 DAC Timeslot 0 left channel enable 0: Disable 1: Enable
14	R/W	0x0	AIF1_DACOR_ENA AIF1 DAC Timeslot 0 right channel enable 0: Disable 1: Enable
13	R/W	0x0	AIF1_DAC1L_ENA AIF1 DAC Timeslot 1 left channel enable 0: Disable 1: Enable
12	R/W	0x0	AIF1_DAC1R_ENA AIF1 DAC Timeslot 1 right channel enable 0: Disable 1: Enable
11:10	R/W	0x0	AIF1_DACOL_SRC AIF1 DAC Timeslot 0 left channel data source select 00: AIF1 DACOL 01: AIF1 DAOR 10: (AIF1 DACOL+AIF1 DACOR) 11: (AIF1 DACOL+AIF1 DACOR)/2
9:8	R/W	0x0	AIF1_DACOR_SRC AIF1 DAC Timeslot 0 right channel data source select 00: AIF1 DACOR 01: AIF1 DACOL 10: (AIF1 DACOL+AIF1 DACOR) 11: (AIF1 DACOL+AIF1 DACOR)/2

7:6	R/W	0x0	AIF1_DAC1L_SRC AIF1 DAC Timeslot 1 left channel data source select 00: AIF1 DAC1L 01: AIF1 DAC1R 10: (AIF1 DAC1L+AIF1 DAC1R) 11: (AIF1 DAC1L+AIF1 DAC1R)/2
5:4	R/W	0x0	AIF1_DAC1R_SRC AIF1 DAC Timeslot 1 right channel data source select 00: AIF1 DAC1R 01: AIF1 DAC1L 10: (AIF1 DAC1L+AIF1 DAC1R) 11: (AIF1 DAC1L+AIF1 DAC1R)/2
3	R/W	0x0	AIF1_DACP_ENA AIF1 DAC Companding enable(8-bit mode only) 00: Disable 01: Enable
2	R/W	0x0	AIF1_DACUL_ENA AIF1 DAC Companding mode select 0: A-law 1: u-law
1	R/W	0x0	Reserved
0	R/W	0x0	AIF1_LOOP_ENA AIF1 loopback enable 0: No loopback 1: Loopback(ADCDAT1 data output to DACDAT1 data input)

3.20.5.27. 0x24C AIF1 Digital Mixer Source Select Register(Default Value: 0x00000000)

Offset: 0x24C			Register Name: AIF1_MXR_SRC
Bit	R/W	Default/Hex	Description
15:12	R/W	0x0	AIF1_ADCOL_MXL_SRC AIF1 ADC Timeslot 0 left channel mixer source select 0: Disable 1: Enable Bit15: AIF1 DACOL data Bit14: AIF2 DACL data Bit13: ADCL data Bit12: AIF2 DACR data
11:8	R/W	0x0	AIF1_ADCOR_MXR_SRC AIF1 ADC Timeslot 0 right channel mixer source select 0: Disable 1: Enable Bit11: AIF1 DACOR data Bit10: AIF2 DACR data Bit9: ADCR data

			Bit8: AIF2 DACL data
7:6	R/W	0x0	AIF1_ADC1L_MXR_SRC AIF1 ADC Timeslot 1 left channel mixer source select 0: Disable 1: Enable Bit7: AIF2 DACL data Bit6: ADCL data
5:4	R/W	0x0	Reserved
3:2	R/W	0x0	AIF1_ADC1R_MXR_SRC AIF1 ADC Timeslot 1 right channel mixer source select 0: Disable 1: Enable Bit3: AIF2 DACR data Bit2: ADCR data
1:0	R/W	0x0	Reserved

3.20.5.28. 0x250 AIF1 Volume Control 1 Register(Default Value: 0x0000A0A0)

Offset: 0x250			Register Name: AIF1_VOL_CTRL1
Bit	R/W	Default/Hex	Description
15:8	R/W	0xA0	AIF1_ADC0L_VOL AIF1 ADC Timeslot 0 left channel volume (-119.25dB To 71.25dB, 0.75dB/Step) 0x00: Mute 0x01: -119.25dB 0x9F = -0.75dB 0xA0 = 0dB 0xA1 = 0.75dB 0xFF = 71.25dB
7:0	R/W	0xA0	AIF1_ADC0R_VOL AIF1 ADC Timeslot 0 right channel volume (-119.25dB To 71.25dB, 0.75dB/Step) 0x00: Mute 0x01: -119.25dB 0x9F = -0.75dB 0xA0 = 0dB 0xA1 = 0.75dB 0xFF = 71.25dB

3.20.5.29. 0x254 AIF1 Volume Control 2 Register(Default Value: 0x0000A0A0)

Offset: 0x254			Register Name: AIF1_VOL_CTRL2
Bit	R/W	Default/Hex	Description
15:8	R/W	0xA0	<p>AIF1_ADC1L_VOL AIF1 ADC Timeslot 1 left channel volume (-119.25dB To 71.25dB, 0.75dB/Step) 0x00: Mute 0x01: -119.25dB 0x9F = -0.75dB 0xA0 = 0dB 0xA1 = 0.75dB 0xFF = 71.25dB</p>
7:0	R/W	0xA0	<p>AIF1_ADC1R_VOL AIF1 ADC Timeslot 1 right channel volume (-119.25dB To 71.25dB, 0.75dB/Step) 0x00: Mute 0x01: -119.25dB 0x9F = -0.75dB 0xA0 = 0dB 0xA1 = 0.75dB 0xFF = 71.25dB</p>

3.20.5.30. 0x258 AIF1 Volume Control 3 Register(Default Value: 0x0000A0A0)

Offset: 0x258			Register Name: AIF1_VOL_CTRL3
Bit	R/W	Default/Hex	Description
15:8	R/W	0xA0	<p>AIF1_DAC0L_VOL AIF1 DAC Timeslot 0 left channel volume (-119.25dB To 71.25dB, 0.75dB/Step) 0x00: Mute 0x01: -119.25dB 0x9F = -0.75dB 0xA0 = 0dB 0xA1 = 0.75dB 0xFF = 71.25dB</p>

7:0	R/W	0xA0	<p>AIF1_DAC0R_VOL AIF1 DAC Timeslot 0 right channel volume (-119.25dB To 71.25dB, 0.75dB/Step)</p> <p>0x00: Mute 0x01: -119.25dB 0x9F = -0.75dB 0xA0 = 0dB 0xA1 = 0.75dB 0xFF = 71.25dB</p>
-----	-----	------	---

3.20.5.31. 0x25C AIF1 Volume Control 4 Register(Default Value: 0x0000A0A0)

Offset: 0x25C			Register Name: AIF1_VOL_CTRL4
Bit	R/W	Default/Hex	Description
15:8	R/W	0xA0	<p>AIF1_DAC0L_VOL AIF1 DAC Timeslot 0 left channel volume (-119.25dB To 71.25dB, 0.75dB/Step)</p> <p>0x00: Mute 0x01: -119.25dB 0x9F = -0.75dB 0xA0 = 0dB 0xA1 = 0.75dB 0xFF = 71.25dB</p>
7:0	R/W	0xA0	<p>AIF1_DAC1R_VOL AIF1 DAC Timeslot 1 right channel volume (-119.25dB To 71.25dB, 0.75dB/Step)</p> <p>0x00: Mute 0x01: -119.25dB 0x9F = -0.75dB 0xA0 = 0dB 0xA1 = 0.75dB 0xFF = 71.25dB</p>

3.20.5.32. 0x260 AIF1 Digital Mixer Gain Control Register(Default Value: 0x00000000)

Offset: 0x260			Register Name: AIF1_MXR_GAIN
Bit	R/W	Default/Hex	Description
15:12	R/W	0x0	AIF1_ADCOL_MXR_GAIN AIF1 ADC Timeslot 0 left channel mixer gain control 0: 0dB 1: -6dB Bit15: AIF1 DACOL data Bit14: AIF2 DACL data Bit13: ADCL data Bit12: AIF2 DACR data
11:8	R/W	0x0	AIF1_ADCOR_MXR_GAIN AIF1 ADC Timeslot 0 right channel mixer gain control 0: 0dB 1: -6dB Bit11: AIF1 DACOR data Bit10: AIF2 DACR data Bit9: ADCR data Bit8: AIF2 DACL data
7:6	R/W	0x0	AIF1_ADC1L_MXR_GAIN AIF1 ADC Timeslot 1 left channel mixer gain control 0: 0dB 1: -6dB Bit7: AIF2 DACL data Bit6: ADCL data
5:4	R/W	0x0	Reserved
3:2	R/W	0x0	AIF1_ADC1R_MXR_GAIN AIF1 ADC Timeslot 1 right channel mixer gain control 0: 0dB 1: -6dB Bit3: AIF2 DACR data Bit2: ADCR data
1:0	R/W	0x0	Reserved

3.20.5.33. 0x264 AIF1 Receiver Data Discarding Control Register(Default Value: 0x00000000)

Offset: 0x264			Register Name: AIF1_RXD_CTRL
Bit	R/W	Default/Hex	Description
15:8	R/W	0x0	After data receiving progress begins, the first N-data will be discarded. N defined as follows: 0x00: None discarded 0x01: 1-data discarded ... 0xFF: 255-data discarded
7:0	R/W	0x0	Reserved

3.20.5.34. 0x280 AIF2 BCLK/LRCK Control Register(Default Value: 0x00000000)

Offset: 0x280			Register Name: AIF2_CLK_CTRL
Bit	R/W	Default/Hex	Description
15	R/W	0x0	AIF2_MSTR_MOD AIF2 Audio Interface mode select 0 = Master mode 1 = Slave mode
14	R/W	0x0	AIF2_BCLK_INV AIF2 BCLK Polarity 0: Normal 1: Inverted
13	R/W	0x0	AIF2_LRCK_INV AIF2 LRCK Polarity 0: Normal 1: Inverted
12:9	R/W	0x0	AIF2_BCLK_DIV Select the AIF2CLK/BCLK2 ratio 0000: AIF2CLK/1 0001: AIF2CLK/2 0010: AIF2CLK/4 0011: AIF2CLK/6 0100: AIF2CLK/8 0101: AIF2CLK/12 0110: AIF2CLK/16 0111: AIF2CLK/24 1000: AIF2CLK/32 1001: AIF2CLK/48 1010: AIF2CLK/64 1011: AIF2CLK/96 1100: AIF2CLK/128 1101: AIF2CLK/192 1110: Reserved 1111: Reserved
8:6	R/W	0x0	AIF2_LRCK_DIV Select the BCLK2/LRCK2 ratio 000: 16 001: 32 010: 64 011: 128 100: 256 1xx: Reserved
5:4	R/W	0x0	AIF2_WORD_SIZ AIF2 digital interface word length

			00: 8bit 01: 16bit 10: 20bit 11: 24bit
3:2	R/W	0x0	AIF2_DATA_FMT AIF digital interface data format 00: I2S mode 01: Left mode 10: Right mode 11: DSP mode
1	R/W	0x0	AIF2_MONO_PCM AIF2 Mono PCM mode select 0: Stereo mode select 1: Mono mode select
0	R/W	0x0	Reserved

3.20.5.35. 0x284 AIF2 ADCDAT Control Register(Default Value: 0x00000000)

Offset: 0x284			Register Name: AIF2_ADCCAT_CTRL
Bit	R/W	Default/Hex	Description
15	R/W	0x0	AIF2_ADCL_EN AIF2 ADC left channel enable 0: Disable 1: Enable
14	R/W	0x0	AIF2_ADCR_EN AIF2 ADC right channel enable 0: Disable 1: Enable
13:12	R/W	0x0	Reserved
11:10	R/W	0x0	AIF2_ADCL_SRC AIF2 ADC left channel data source select 00: AIF2 ADCL 01: AIF2 ADCR 10: (AIF2 ADCL+AIF2 ADCR) 11: (AIF2 ADCL+AIF2 ADCR)/2
9:8	R/W	0x0	AIF2_ADCR_SRC AIF2 ADC right channel data source select 00: AIF2 ADCR 01: AIF2 ADCL 10: (AIF2 ADCL+AIF2 ADCR) 11: (AIF2 ADCL+AIF2 ADCR)/2
7:4	R/W	0x0	Reserved
3	R/W	0x0	AIF2_ADCP_ENA

			AIF2 ADC Companding enable(8-bit mode only) 00: Disable 01: Enable
2	R/W	0x0	AIF2_ADCUL_ENA AIF2 ADC Companding mode select 0: A-law 1: u-law
1	/	/	/
0	R/W	0x0	AIF2_LOOP_EN AIF2 loopback enable 0: No loopback 1: Loopback(ADCDAT2 data output to DACDAT2 data input)

3.20.5.36. 0x288 AIF2 DACDAT Control Register(Default Value: 0x00000000)

Offset: 0x288			Register Name: AIF2_DACDAT_CTRL
Bit	R/W	Default/Hex	Description
15	R/W	0x0	AIF2_DACL_ENA AIF2 DAC left channel enable 0: Disable 1: Enable
14	R/W	0x0	AIF2_DACR_ENA AIF2 DAC right channel enable 0: Disable 1: Enable
13:12	R/W	0x0	Reserved
11:10	R/W	0x0	AIF2_DACL_SRC AIF2 DAC left channel data source select 00: AIF2 DACL 01: AIF2 DACR 10: (AIF2 DACL+AIF2 DACR) 11: (AIF2 DACL+AIF2 DACR)/2
9:8	R/W	0x0	AIF2_DACR_SRC AIF2 DAC right channel data source select 00: AIF2 DACR 01: AIF2 DACL 10: (AIF2 DACL+AIF2 DACR) 11: (AIF2 DACL+AIF2 DACR)/2
7:4	R/W	0x0	Reserved
3	R/W	0x0	AIF2_DACP_ENA AIF2 DAC Companding enable(8-bit mode only) 00: Disable 01: Enable

2	R/W	0x0	AIF2_DACUL_ENA AIF2 DAC Companding mode select 0: A-law 1: u-law
1	R/W	0x0	Reserved
0	R/W	0x0	/

3.20.5.37. 0x28C AIF2 Digital Mixer Source Select Register(Default Value: 0x00000000)

Offset: 0x28C			Register Name: AIF2_MXR_SRC
Bit	R/W	Default/Hex	Description
15:12	R/W	0x0	AIF2_ADCL_MXR_SRC AIF2 ADC left channel mixer source select 0: Disable 1:Enable Bit15: AIF1 DAC0L data Bit14: AIF1 DAC1L data Bit13: AIF2 DACR data Bit12: ADCL data
11:8	R/W	0x0	AIF2_ADCR_MXR_SRC AIF2 ADC right channel mixer source select 0: Disable 1:Enable Bit11: AIF1 DA0R data Bit10: AIF1 DA1R data Bit9: AIF2 DACL data Bit8: ADCR data
7:0	R/W	0x0	Reserved

3.20.5.38. 0x290 AIF2 Volume Control 1 Register(Default Value: 0x0000A0A0)

Offset: 0x290			Register Name: AIF2_VOL_CTRL1
Bit	R/W	Default/Hex	Description
15:8	R/W	0xA0	AIF2_ADCL_VOL AIF2 ADC left channel volume (-119.25dB To 71.25dB, 0.75dB/Step) 0x00: Mute 0x01: -119.25dB 0x9F = -0.75dB 0xA0 = 0dB 0xA1 = 0.75dB

			0xFF = 71.25dB
7:0	R/W	0xA0	<p>AIF2_ADCR_VOL AIF2 ADC right channel volume (-119.25dB To 71.25dB, 0.75dB/Step) 0x00: Mute 0x01: -119.25dB 0x9F = -0.75dB 0xA0 = 0dB 0xA1 = 0.75dB 0xFF = 71.25dB</p>

3.20.5.39. 0x298 AIF2 Volume Control 2 Register(Default Value: 0x0000A0A0)

Offset: 0x298			Register Name: AIF2_VOL_CTRL2
Bit	R/W	Default/Hex	Description
15:8	R/W	0xA0	<p>AIF2_ADCL_VOL AIF2 ADC left channel volume (-119.25dB To 71.25dB, 0.75dB/Step) 0x00: Mute 0x01: -119.25dB 0x9F = -0.75dB 0xA0 = 0dB 0xA1 = 0.75dB 0xFF = 71.25dB</p>
7:0	R/W	0xA0	<p>AIF2_DACR_VOL AIF2 DAC right channel volume (-119.25dB To 71.25dB, 0.75dB/Step) 0x00: Mute 0x01: -119.25dB 0x9F = -0.75dB 0xA0 = 0dB 0xA1 = 0.75dB 0xFF = 71.25dB</p>

3.20.5.40. 0x2A0 AIF2 Digital Mixer Gain Control Register(Default Value: 0x00000000)

Offset: 0x2A0			Register Name: AIF2_MXR_GAIN
Bit	R/W	Default/Hex	Description
15:12	R/W	0x0	AIF2_ADCL_MXR_GAIN AIF2 ADC left channel mixer gain control 0: 0dB 1: -6dB Bit15: AIF1 DAC0L data Bit14: AIF1 DAC1L data Bit13: AIF2 DACR data Bit12: ADCL data
11:8	R/W	0x0	AIF2_ADCR_MXR_GAIN AIF2 ADC right channel mixer gain control 0: 0dB 1: -6dB Bit11: AIF1 DAC0R data Bit10: AIF1 DAC1R data Bit9: AIF2 DACL data Bit8: ADCR data
7:0	R/W	0x0	Reserved

3.20.5.41. 0x2A4 AIF2 Receiver Data Discarding Control Register(Default Value: 0x00000000)

Offset: 0x2A4			Register Name: AIF2_RXD_CTRL
Bit	R/W	Default/Hex	Description
15:8	R/W	0x0	After data receiving progress begins, the first N-data will be discarded. N defined as follows: 0x00: None discarded 0x01: 1-data discarded ... 0xFF: 255-data discarded
7:0	R/W	0x0	Reserved

3.20.5.42. 0x2C0 AIF3 BCLK/LRCK Control Register(Default Value: 0x00000000)

Offset: 0x2C0			Register Name: AIF3_CLK_CTRL
Bit	R/W	Default/Hex	Description
15	R/W	0x0	Reserved
14	R/W	0x0	AIF3_BCLK_INV AIF3 BCLK Polarity 0: Normal 1: Inverted

13	R/W	0x0	AIF3_LRCK_INV AIF3 LRCK Polarity 0: Normal 1: Inverted
12:6	R/W	0x0	Reserved
5:4	R/W	0x0	AIF3_WORD_SIZ AIF3 digital interface word length 00: 8bit 01: 16bit 10: 20bit 11: 24bit
3:2	R/W	0x0	Reserved
1:0	R/W	0x0	AIF3_CLOCK_SRC AIF3 BCLK/LRCK source control 0: BCLK/LRCK Come from AIF1 1: BCLK/LRCK Come from AIF2 2: BCLK/LRCK is generated by AIF3, and the source clock is AIF1CLK 3: Reserved

3.20.5.43. 0x2C4 AIF3 ADCDAT Control Register(Default Value: 0x00000000)

Offset: 0x2C4			Register Name: AIF3_ADCCAT_CTRL
Bit	R/W	Default/Hex	Description
15:4	R/W	0x0	Reserved
3	R/W	0x0	AIF3_ADCP_ENA AIF3 ADC Companding enable 00: Disable 01: Enable
2	R/W	0x0	AIF3_ADUL_ENA AIF3 ADC Companding mode select 0: A-law 1: u-law
1:0	R/W	0x0	Reserved

3.20.5.44. 0x2C8 AIF3 DACDAT Control Register(Default Value: 0x00000000)

Offset: 0x2C8			Register Name: AIF3_DACDAT_CTRL
Bit	R/W	Default/Hex	Description
15:4	R/W	0x0	Reserved
3	R/W	0x0	AIF3_DACP_ENA AIF3 DAC Companding enable(8-bit mode only)

			00: Disable 01: Enable
2	R/W	0x0	AIF3_DAUL_ENA AIF3 DAC Comanding mode select 00: u-law 01: A-law
1	R/W	0x0	Reserved
0	R/W	0x0	AIF3_LOOP_ENA AIF3 loopback enable 0: No loopback 1: Loopback(ADCDAT3 data output to DACDAT3 data input)

3.20.5.45. 0x2CC AIF3 Signal Path Control Register(Default Value: 0x00000000)

Offset: 0x2CC			Register Name: AIF3_SGP_CTRL
Bit	R/W	Default/Hex	Description
15:12	R/W	0x0	Reserved
11:10	R/W	0x0	AIF3_ADC_SRC AIF3 PCM output source select 00: None 01: AIF2 ADC left channel 10: AIF2 ADC right channel 11: Reserved
9:8	R/W	0x0	AIF2_DAC_SRC AIF2 DAC input source select 00: Left and right inputs from AIF2 01: Left input from AIF3; Right input from AIF2 10: Left input from AIF2; Right input from AIF3 11: Reserved
7	R/W	0x0	AIF3_PINS_TRI AIF3 Pins Tri-state Control 0 = AIF3 pins operate normally 1 = Tri-state all AIF3 interface pins
6:4	R/W	0x0	reserved
3	R/W	0x0	reserved
2	R/W	0x0	reserved
1	R/W	0x0	reserved
0	R/W	0x0	reserved

3.20.5.46. 0x2E4 AIF3 Receiver Data Discarding Control Register(Default Value: 0x00000000)

Offset: 0x2E4			Register Name: AIF3_RXD_CTRL
Bit	R/W	Default/Hex	Description
15:8	R/W	0x0	After data receiving progress begins, the first N-data will be discarded. N defined as follows: 0x00: None discarded 0x01: 1-data discarded ... 0xFF: 255-data discarded
7:0	R/W	0x0	Reserved

3.20.5.47. 0x300 ADC Digital Control Register(Default Value: 0x00000000)

Offset: 0x300			Register Name: ADC_DIG_CTRL
Bit	R/W	Default/Hex	Description
15	R/W	0x0	ENAD ADC Digital part enable 0: Disable 1: Enable
14	R/W	0x0	ENDM Digital microphone enable 0: Analog ADC mode 1:
13	R/W	0x0	ADFIR32 Enable 32-tap FIR filter 0: 64-tap 1: 32-tap
12:5	R/W	0x0	Reserved
4	R/W	0x0	DOSR Digital Microphone Oversample Rate Select 0: 128fs 1: 64fs
3:2	R/W	0x0	ADOUT_DTS ADC Delay Time For transmitting data after ENAD 00:5ms 01:10ms 10:20ms 11:30ms
1	R/W	0x0	ADOUT_DLY ADC Delay Function enable for transmitting data after ENAD 0: Disable

			1: Enable
0	R/W	0x0	DOSR Digital Microphone Oversampling Rate 0:64 fs 1:128fs

3.20.5.48. 0x304 ADC Volume Control Register(Default Value: 0x0000A0A0)

Offset: 0x304			Register Name: ADC_VOL_CTRL
Bit	R/W	Default/Hex	Description
15:8	R/W	0xA0	ADC_VOL_L ADC left channel volume (-119.25dB To 71.25dB, 0.75dB/Step) 0x00: Mute 0x01: -119.25dB 0x9F = -0.75dB 0xA0 = 0dB 0xA1 = 0.75dB 0xFF = 71.25dB
7:0	R/W	0xA0	ADC_VOL_R ADC left channel volume (-119.25dB To 71.25dB, 0.75dB/Step) 0x00: Mute 0x01: -119.25dB 0x9F = -0.75dB 0xA0 = 0dB 0xA1 = 0.75dB 0xFF = 71.25dB

3.20.5.49. 0x308 ADC Debug Control Register(Default Value: 0x00000000)

Offset: 0x308			Register Name: ADC_DBG_CTRL
Bit	R/W	Default/Hex	Description
15	R/W	0x0	ADSW ADC input channel swap enable 0: Disable 1: Enable

14	R/W	0x0	Reserved																																																
13:12	R/W	0x0	/																																																
11:3	R/W	0x0	Reserved																																																
2:0	R/W	0x0	<p>Interface between ADDA digital part and ADDA analog part debug control.</p> <ul style="list-style-type: none"> Normal Normal BCLK2/LRCK2/ADCDAT2/DACDAT2 BCLK3/LRCK3/ADCDAT3/DACDAT3 is multiplexed as follows: <table border="1" data-bbox="657 604 1388 947"> <tr><td>BCLK2</td><td>CKAD_A input to ADC analog part</td></tr> <tr><td>LRCK2</td><td>Normal</td></tr> <tr><td>ADCDAT2</td><td>ADIN_L[1] output from ADC analog part</td></tr> <tr><td>DACDAT2</td><td>ADIN_L[0] output from ADC analog part</td></tr> <tr><td>BCLK3</td><td>CKAD_A output from ADC digital part</td></tr> <tr><td>LRCK3</td><td>Normal</td></tr> <tr><td>ADCDAT3</td><td>ADIN_L/R[1] input to ADC digital part</td></tr> <tr><td>DACDAT3</td><td>ADIN_L/R[0] input to ADC digital part</td></tr> </table> BCLK2/LRCK2/ADADAT2/DACDAT2 BCLK3/LRCK3/ADCDAT3/DACDAT3 is multiplexed as follows: <table border="1" data-bbox="657 1070 1388 1413"> <tr><td>BCLK2</td><td>CKAD_A input to ADC analog part</td></tr> <tr><td>LRCK2</td><td>Normal</td></tr> <tr><td>ADCDAT2</td><td>ADIN_R[1] output from ADC analog part</td></tr> <tr><td>DACDAT2</td><td>ADIN_R[0] output from ADC analog part</td></tr> <tr><td>BCLK3</td><td>CKAD_A output from ADC digital part</td></tr> <tr><td>LRCK3</td><td>Normal</td></tr> <tr><td>ADCDAT3</td><td>ADIN_L/R[1] input to ADC digital part</td></tr> <tr><td>DACDAT3</td><td>ADIN_L/R[0] input to ADC digital part</td></tr> </table> BCLK2/LRCK2/ADADAT2/DACDAT2 BCLK3/LRCK3/ADCDAT3/DACDAT3 is multiplexed as follows: <table border="1" data-bbox="657 1536 1388 1879"> <tr><td>BCLK2</td><td>CKDA_A output from DAC digital part</td></tr> <tr><td>LRCK2</td><td>DAOUT_L[6] output from DAC digital part</td></tr> <tr><td>ADCDAT2</td><td>DAOUT_L[5] output from DAC digital part</td></tr> <tr><td>DACDAT2</td><td>DAOUT_L[4] output from DAC digital part</td></tr> <tr><td>BCLK3</td><td>DAOUT_L[3] output from DAC digital part</td></tr> <tr><td>LRCK3</td><td>DAOUT_L[2] output from DAC digital part</td></tr> <tr><td>ADCDAT3</td><td>DAOUT_L[1] output from DAC digital part</td></tr> <tr><td>DACDAT3</td><td>DAOUT_L[0] output from DAC digital part</td></tr> </table> BCLK2/LRCK2/ADADAT2/DACDAT2 BCLK3/LRCK3/ADCDAT3/DACDAT3 is multiplexed as follows: 	BCLK2	CKAD_A input to ADC analog part	LRCK2	Normal	ADCDAT2	ADIN_L[1] output from ADC analog part	DACDAT2	ADIN_L[0] output from ADC analog part	BCLK3	CKAD_A output from ADC digital part	LRCK3	Normal	ADCDAT3	ADIN_L/R[1] input to ADC digital part	DACDAT3	ADIN_L/R[0] input to ADC digital part	BCLK2	CKAD_A input to ADC analog part	LRCK2	Normal	ADCDAT2	ADIN_R[1] output from ADC analog part	DACDAT2	ADIN_R[0] output from ADC analog part	BCLK3	CKAD_A output from ADC digital part	LRCK3	Normal	ADCDAT3	ADIN_L/R[1] input to ADC digital part	DACDAT3	ADIN_L/R[0] input to ADC digital part	BCLK2	CKDA_A output from DAC digital part	LRCK2	DAOUT_L[6] output from DAC digital part	ADCDAT2	DAOUT_L[5] output from DAC digital part	DACDAT2	DAOUT_L[4] output from DAC digital part	BCLK3	DAOUT_L[3] output from DAC digital part	LRCK3	DAOUT_L[2] output from DAC digital part	ADCDAT3	DAOUT_L[1] output from DAC digital part	DACDAT3	DAOUT_L[0] output from DAC digital part
BCLK2	CKAD_A input to ADC analog part																																																		
LRCK2	Normal																																																		
ADCDAT2	ADIN_L[1] output from ADC analog part																																																		
DACDAT2	ADIN_L[0] output from ADC analog part																																																		
BCLK3	CKAD_A output from ADC digital part																																																		
LRCK3	Normal																																																		
ADCDAT3	ADIN_L/R[1] input to ADC digital part																																																		
DACDAT3	ADIN_L/R[0] input to ADC digital part																																																		
BCLK2	CKAD_A input to ADC analog part																																																		
LRCK2	Normal																																																		
ADCDAT2	ADIN_R[1] output from ADC analog part																																																		
DACDAT2	ADIN_R[0] output from ADC analog part																																																		
BCLK3	CKAD_A output from ADC digital part																																																		
LRCK3	Normal																																																		
ADCDAT3	ADIN_L/R[1] input to ADC digital part																																																		
DACDAT3	ADIN_L/R[0] input to ADC digital part																																																		
BCLK2	CKDA_A output from DAC digital part																																																		
LRCK2	DAOUT_L[6] output from DAC digital part																																																		
ADCDAT2	DAOUT_L[5] output from DAC digital part																																																		
DACDAT2	DAOUT_L[4] output from DAC digital part																																																		
BCLK3	DAOUT_L[3] output from DAC digital part																																																		
LRCK3	DAOUT_L[2] output from DAC digital part																																																		
ADCDAT3	DAOUT_L[1] output from DAC digital part																																																		
DACDAT3	DAOUT_L[0] output from DAC digital part																																																		

				<table border="1"> <tr><td>BCLK2</td><td>CKDA_A output from DAC digital part</td></tr> <tr><td>LRCK2</td><td>DAOUT_R[6] output from DAC digital part</td></tr> <tr><td>ADCDAT2</td><td>DAOUT_R[5] output from DAC digital part</td></tr> <tr><td>DACDAT2</td><td>DAOUT_R[4] output from DAC digital part</td></tr> <tr><td>BCLK3</td><td>DAOUT_R[3] output from DAC digital part</td></tr> <tr><td>LRCK3</td><td>DAOUT_R[2] output from DAC digital part</td></tr> <tr><td>ADCDAT3</td><td>DAOUT_R[1] output from DAC digital part</td></tr> <tr><td>DACDAT3</td><td>DAOUT_R[0] output from DAC digital part</td></tr> </table> <ul style="list-style-type: none"> <p>BCLK2/LRCK2/ADADAT2/DACDAT2 BCLK3/LRCK3/ADCDAT3/DACDAT3 is multiplexed as follows:</p> <table border="1"> <tr><td>BCLK2</td><td>CKDA_A input to DAC analog part</td></tr> <tr><td>LRCK2</td><td>DAOUT_L/R[6] input to DAC analog part</td></tr> <tr><td>ADCDAT2</td><td>DAOUT_L/R[5] input to DAC analog part</td></tr> <tr><td>DACDAT2</td><td>DAOUT_L/R[4] input to DAC analog part</td></tr> <tr><td>BCLK3</td><td>DAOUT_L/R[3] input to DAC analog part</td></tr> <tr><td>LRCK3</td><td>DAOUT_L/R[2] input to DAC analog part</td></tr> <tr><td>ADCDAT3</td><td>DAOUT_L/R[1] input to DAC analog part</td></tr> <tr><td>DACDAT3</td><td>DAOUT_L/R[0] input to DAC analog part</td></tr> </table> <p>BCLK2/LRCK2/ADADAT2/DACDAT2 BCLK3/LRCK3/ADCDAT3/DACDAT3 is multiplexed as follows:</p> <table border="1"> <tr><td>BCLK2</td><td>CKDA_A input to DAC analog part</td></tr> <tr><td>LRCK2</td><td>DAOUT_L/R[6] input to DAC analog part</td></tr> <tr><td>ADCDAT2</td><td>DAOUT_L/R[5] input to DAC analog part</td></tr> <tr><td>DACDAT2</td><td>DAOUT_L/R[4] input to DAC analog part</td></tr> <tr><td>BCLK3</td><td>DAOUT_L/R[3] input to DAC analog part</td></tr> <tr><td>LRCK3</td><td>DAOUT_L/R[2] input to DAC analog part</td></tr> <tr><td>ADCDAT3</td><td>DAOUT_L/R[1] input to DAC analog part</td></tr> <tr><td>DACDAT3</td><td>DAOUT_L/R[0] input to DAC analog part</td></tr> </table> 	BCLK2	CKDA_A output from DAC digital part	LRCK2	DAOUT_R[6] output from DAC digital part	ADCDAT2	DAOUT_R[5] output from DAC digital part	DACDAT2	DAOUT_R[4] output from DAC digital part	BCLK3	DAOUT_R[3] output from DAC digital part	LRCK3	DAOUT_R[2] output from DAC digital part	ADCDAT3	DAOUT_R[1] output from DAC digital part	DACDAT3	DAOUT_R[0] output from DAC digital part	BCLK2	CKDA_A input to DAC analog part	LRCK2	DAOUT_L/R[6] input to DAC analog part	ADCDAT2	DAOUT_L/R[5] input to DAC analog part	DACDAT2	DAOUT_L/R[4] input to DAC analog part	BCLK3	DAOUT_L/R[3] input to DAC analog part	LRCK3	DAOUT_L/R[2] input to DAC analog part	ADCDAT3	DAOUT_L/R[1] input to DAC analog part	DACDAT3	DAOUT_L/R[0] input to DAC analog part	BCLK2	CKDA_A input to DAC analog part	LRCK2	DAOUT_L/R[6] input to DAC analog part	ADCDAT2	DAOUT_L/R[5] input to DAC analog part	DACDAT2	DAOUT_L/R[4] input to DAC analog part	BCLK3	DAOUT_L/R[3] input to DAC analog part	LRCK3	DAOUT_L/R[2] input to DAC analog part	ADCDAT3	DAOUT_L/R[1] input to DAC analog part	DACDAT3	DAOUT_L/R[0] input to DAC analog part
BCLK2	CKDA_A output from DAC digital part																																																			
LRCK2	DAOUT_R[6] output from DAC digital part																																																			
ADCDAT2	DAOUT_R[5] output from DAC digital part																																																			
DACDAT2	DAOUT_R[4] output from DAC digital part																																																			
BCLK3	DAOUT_R[3] output from DAC digital part																																																			
LRCK3	DAOUT_R[2] output from DAC digital part																																																			
ADCDAT3	DAOUT_R[1] output from DAC digital part																																																			
DACDAT3	DAOUT_R[0] output from DAC digital part																																																			
BCLK2	CKDA_A input to DAC analog part																																																			
LRCK2	DAOUT_L/R[6] input to DAC analog part																																																			
ADCDAT2	DAOUT_L/R[5] input to DAC analog part																																																			
DACDAT2	DAOUT_L/R[4] input to DAC analog part																																																			
BCLK3	DAOUT_L/R[3] input to DAC analog part																																																			
LRCK3	DAOUT_L/R[2] input to DAC analog part																																																			
ADCDAT3	DAOUT_L/R[1] input to DAC analog part																																																			
DACDAT3	DAOUT_L/R[0] input to DAC analog part																																																			
BCLK2	CKDA_A input to DAC analog part																																																			
LRCK2	DAOUT_L/R[6] input to DAC analog part																																																			
ADCDAT2	DAOUT_L/R[5] input to DAC analog part																																																			
DACDAT2	DAOUT_L/R[4] input to DAC analog part																																																			
BCLK3	DAOUT_L/R[3] input to DAC analog part																																																			
LRCK3	DAOUT_L/R[2] input to DAC analog part																																																			
ADCDAT3	DAOUT_L/R[1] input to DAC analog part																																																			
DACDAT3	DAOUT_L/R[0] input to DAC analog part																																																			

3.20.5.50. 0x310 HMIC Control 1 Register(Default Value: 0x00000020)

Offset: 0x310			Register Name: HMIC_CTRL1
Bit	R/W	Default/Hex	Description
15:12	R/W	0x0	HMIC_M Debounce when the MIC Key down or up.
11:8	R/W	0x0	Reserved to 0xf
7	/	/	/
6:5	R/W	0x1	MDATA_Threshold_Debounce 00:0 01:1

			10:2 11: Reserve(default 1)
4	R/W	0x0	JACK_IN_IRQ_EN MIC Detect Interrupt Set 0 : disable 1 : enable
3	R/W	0x0	JACK_OUT_IRQ_EN MIC Detect Interrupt Set 0 : disable 1 : enable
2:1	/	/	/
0	R/W	0x0	MIC_DET_IRQ_EN MIC Detect Interrupt Set 0:disable 1:enable

3.20.5.51. 0x314 HMIC Control 2 Register(Default Value: 0x00000000)

Offset: 0x314			Register Name: HMIC_CTRL2
Bit	R/W	Default/Hex	Description
15:14	R/W	0x0	HMIC_SAMPLE_SELECT Down Sample Setting Select 00 : Down by 1, 128Hz 01 : Down by 2, 64Hz 10 : Down by 4, 32Hz 11 : Down by 8, 16Hz
13	/	/	/
12:8	R/W	0x0	MDATA_Threshold MIC DATA De-Bounce DATA
7:6	R/W	0x0	HMIC_SF Hmic Smooth Filter setting 00: by pass 01: (x1+x2)/2 10: (x1+x2+x3+x4)/4 11: (x1+x2+x3+x4+x5+x6+x7+x8)/8
5:0	/	/	

3.20.5.52. 0x318 HMIC Status Register(Default Value: 0x00000000)

Offset: 0x318			Register Name: HMIC_STS
Bit	R/W	Default/Hex	Description

15	R/W	0x1	MDATA_Threshold_EN 0 : The MIC Threshold Data write by user 1 : The MIC Threshold Data is auto write
14:13	R/W	0x3	MDATA_DISCARD After MIC DATA data receiving, the first N-data will be discarded. N defined as follows: 00 : 0; None discarded 01 : 1; 1-data discarded 10 : 2; 2-data discarded 11 : 4; 4-data discarded
12:8	R	0x0	HMIC_DATA HMIC Average Data
7	/	/	/
6	R/W	0x0	Jack Detect Status 0:Not MIC/Accessory present 1:MIC/Accessory is present(impedance is < 30K ohm)
5	/	/	/
4	R/W	0x0	JACK_DET_OIRQ Jack output detect pending interrupt 0: No Pending IRQ 1:Pending IRQ Writing 1 clear pending
3	R/W	0x0	JACK_DET_IIRQ Jack input detect pending interrupt 0: No Pending IRQ 1: Pending IRQ Writing 1 clear pending
2:1	/	/	/
0	R/W	0x0	MIC_DET_ST. MIC Detect Pending interrupt 0:No pending IRQ 1:Pending IRQ Writing 1 clear pending

3.20.5.53. 0x320 DAC Digital Control Register(Default Value: 0x00000000)

Offset: 0x320			Register Name: DAC_DIG_CTRL
Bit	R/W	Default/Hex	Description
15	R/W	0x0	ENDA. DAC Digital Part Enable 0: Disabe 1: Enable
14	R/W	0x0	ENHPF

			HPF Function Enable 0: Enable 1: Disable
13	R/W	0x0	DAFIR32 Enable 32-tap FIR filter 0: 64-tap 1: 32-tap
12	R/W	0x0	Reserved
11:8	R/W	0x0	MODQU Internal DAC Quantization Levels Levels= $[7*(21+MODQU[3:0])]/128$ Default levels= $7*21/128=1.15$
7:0	R/W	0x0	Reserved

3.20.5.54. 0x324 DAC Volume Control Register(Default Value: 0x000A0A0)

Offset: 0x324			Register Name: DAC_VOL_CTRL
Bit	R/W	Default/Hex	Description
15:8	R/W	0xA0	DAC_VOL_L DAC left channel volume (-119.25dB To 71.25dB, 0.75dB/Step) 0x00: Mute 0x01: -119.25dB 0x9F = -0.75dB 0xA0 = 0dB 0xA1 = 0.75dB 0xFF = 71.25dB
7:0	R/W	0xA0	DAC_VOL_R DAC right channel volume (-119.25dB To 71.25dB, 0.75dB/Step) 0x00: Mute 0x01: -119.25dB 0x9F = -0.75dB 0xA0 = 0dB 0xA1 = 0.75dB 0xFF = 71.25dB

3.20.5.55. 0x328 DAC Debug Control Register(Default Value: 0x00000000)

Offset: 0x328			Register Name: DAC_DBG_CTRL
Bit	R/W	Default/Hex	Description
15	R/W	0x0	DASW DAC output channel swap enable 0:Disable 1:Enable
14	R/W	0x0	ENDWA_N DWA Function Disable 0: Enable 1: Disable
13	R/W	0x0	DAC_MOD_DBG DAC Modulator Debug 0: DAC Modulator Normal Mode 1: DAC Modulator Debug Mode
12:8	R/W	0x0	Reserved
7:6	R/W	0x0	DAC_PTN_SEL DAC Pattern Select 00: Normal(Audio sample from DAC mixer) 01: -6 dB sin wave 10: -60 dB sin wave 11: zero data
5:0	R/W	0x0	DVC Digital volume control, ATT=DVC[5:0]*(-1.16dB) 64 steps, -1.16dB/step

3.20.5.56. 0x330 DAC Digital Mixer Source Select Register(Default Value: 0x00000000)

Offset: 0x330			Register Name: DAC_MXR_SRC
Bit	R/W	Default/Hex	Description
15:12	R/W	0x0	DACL_MXR_SRC DAC left channel mixer source select 0: Disable 1:Enable Bit15: AIF1 DAC0L Bit14: AIF1 DAC1L Bit13: AIF2 DACL Bit12: ADCL
11:8	R/W	0x0	DACR_MXR_SRC DAC right channel mixer source select 0: Disable 1:Enable Bit11: AIF1 DAC0R

			Bit10: AIF1 DAC1R Bit9: AIF2 DACR Bit8: ADCR
7:0	R/W	0x0	Reserved

3.20.5.57. 0x334 DAC Digital Mixer Gain Control Register(Default Value: 0x00000000)

Offset: 0x334			Register Name: DAC_MXR_GAIN
Bit	R/W	Default/Hex	Description
15:12	R/W	0x0	DACL_MXR_GAIN DAC left channel mixer gain control 0: 0dB 1: -6dB Bit15: AIF1 DAC0L Bit14: AIF1 DAC1L Bit13: AIF2 DACL Bit12: ADCL
11:8	R/W	0x0	DACR_MXR_GAIN DAC right channel mixer gain control 0: 0dB 1: -6dB Bit11: AIF1 DAC0R Bit10: AIF1 DAC1R Bit9: AIF2 DACR Bit8: ADCR
7:0	R/W	0x0	Reserved

3.20.5.58. 0x400 ADC DAP Left Status Register(Default Value: 0x00000000)

Offset: 0x400			Register Name: AC_ADC_DAPLSTA
Bit	R/W	Default/Hex	Description
15:10	R	0x0	Reserved
9	R	0x0	Left AGC saturation flag
8	R	0x0	Left AGC noise-threshold flag
7:0	R	0x0	Left Gain applied by AGC (7.1 format 2s complement(-20dB – 40dB), 0.5B/ step) 0x50: 40dB 0x4F: 39.5dB ----- 0x00: 00dB 0xFF: -0.5dB

3.20.5.59. 0x404 ADC DAP Right Status Register(Default Value: 0x00000000)

Offset: 0x404			Register Name: AC_ADC_DAPRSTA
Bit	R/W	Default/Hex	Description
11:10	R	0x0	Reserved
9	R	0x0	Right AGC saturation flag
8	R	0x0	Right AGC noise-threshold flag
7:0	R	0x0	Right Gain applied by AGC (7.1 format 2s complement(-20dB – 40dB), 0.5dB /step) 0x50: 40dB 0x4F: 39.5dB ----- 0x00: 00dB 0xFF: -0.5dB

3.20.5.60. 0x408 ADC DAP Left Channel Control Register(Default Value: 0x00000000)

Offset: 0x408			Register Name: AC_ADC_DAPLCTRL
Bit	R/W	Default/Hex	Description
15	/	/	/
14	R/W	0x0	Left AGC enable 0: disable 1: enable
13	R/W	0x0	Left HPF enable 0: disable 1: enable
12	R/W	0x0	Left Noise detect enable 0: disable 1: enable
11:10	R/W	0x0	Reserved
9:8	R/W	0x0	Left Hysteresis setting 00: 1dB 01: 2dB 10: 4dB 11: disable;
7:4	R/W	0x0	Left Noise debounce time 0000: disable 0001: 4/fs 0010: 8/fs ----- 1111: 16*4096/fs $T=2^{(N+1)}/fs$, except N=0
3:0	R/W	0x0	Left Signal debounce time 0000: disable 0001: 4/fs

			0010: 8/fs ----- 1111: 16*4096/fs $T=2^{(N+1)}/fs$, except N=0
--	--	--	--

3.20.5.61. 0x40C ADC DAP Right Channel Control Register(Default Value: 0x00000000)

Offset: 0x40C			Register Name: AC_ADC_DAPRCTRL
Bit	R/W	Default/Hex	Description
15	/	/	/
14	R/W	0x0	Right AGC enable 0: disable 1: enable
13	R/W	0x0	Right HPF enable 0: disable 1: enable
12	R/W	0x0	Right Noise detect enable 0: disable 1: enable
11:10	R/W	0x0	Reserved
9: 8	R/W	0x0	Right Hysteresis setting 00: 1dB 01: 2dB 10: 4dB 11: disable
7: 4	R/W	0x0	Right Noise debounce time 0000: disable 0001: 4/fs 0010: 8/fs ----- 1111: 16*4096/fs $T=2^{(N+1)}/fs$, except N=0
3: 0	R/W	0x0	Right Signal debounce time 0000: disable 0001: 4/fs 0010: 8/fs ----- 1111: 16*4096/fs $T=2^{(N+1)}/fs$, except N=0

3.20.5.62. 0x410 ADC DAP Left Target Level Register(Default Value: 0x00002C28)

Offset: 0x410			Register Name: AC_ADC_DAPLTL
Bit	R/W	Default/Hex	Description

15:14	/	/	/
13:8	R/W	0x2C(-20dB)	Left channel target level setting(-1dB -- -30dB).(6.0format 2s complement)
7:0	R/W	0x28(20dB)	Left channel max gain setting(0-40dB).(7.1format 2s complement)

3.20.5.63. 0x414 ADC DAP Right Target Level Register(Default Value: 0x00002C28)

Offset: 0x414			Register Name: AC_ADC_DAPRTL
Bit	R/W	Default/Hex	Description
15:14	/	/	/
13:8	R/W	0x2C(-20dB)	Right channel target level setting(-1dB -- -30dB).(6.0format 2s complement)
7:0	R/W	0x28(20dB)	Right channel max gain setting (0-40dB). (7.1format 2s complement)

3.20.5.64. 0x418 ADC DAP Left High Average Coef Register(Default Value: 0x00000005)

Offset: 0x418			Register Name: AC_ADC_DAPLHAC
Bit	R/W	Default/Hex	Description
15:11	/	/	/
10:0	R/W	0x0005	Left channel output signal average level coefficient setting(the coefficient [reg06[10:0],reg07] is 3.24 format 2s complement)

3.20.5.65. 0x41C ADC DAP Left Low Average Coef Register(Default Value: 0x00001EB8)

Offset: 0x41C			Register Name: AC_ADC_DAPLHAC
Bit	R/W	Default/Hex	Description
15:0	R/W	0x1EB8	Left channel output signal average level coefficient setting(the coefficient [reg07[10:0],reg08] is 3.24 format 2s complement)

3.20.5.66. 0x420 ADC DAP Right High Average Coef Register(Default Value: 0x00000005)

Offset: 0x420			Register Name: AC_ADC_DAPRHAC
Bit	R/W	Default/Hex	Description
15:11	/	/	/
10:0	R/W	0x0005	Right channel output signal average level coefficient setting(the coefficient [reg08[10:0],reg09] is 3.24 format 2s complement)

3.20.5.67. 0x424 ADC DAP Right Low Average Coef Register(Default Value: 0x00001EB8)

Offset: 0x424			Register Name: AC_ADC_DAPRLAC
Bit	R/W	Default/Hex	Description
15:0	R/W	0x1EB8	Right channel output signal average level coefficient setting(the coefficient [reg08[10:0],reg09] is 3.24 format 2s complement)

3.20.5.68. 0x428 ADC DAP Left Decay Time Register(Default Value: 0x0000001F)

Offset: 0x428			Register Name: AC_ADC_DAPLDT
Bit	R/W	Default/Hex	Description
15	/	/	/
14:0	R/W	0x001F (32x32fs)	Left decay time coefficient setting 0000: 1x32/fs 0001: 2x32/fs ----- 7FFF: 2 ¹⁵ x32/fs T=(n+1)*32/fs When the gain increases, the actual gain will increase 0.5dB at every decay time.

3.20.5.69. 0x42C ADC DAP Left Attack Time Register(Default Value: 0x00000000)

Offset: 0x42C			Register Name: AC_ADC_DAPLAT
Bit	R/W	Default/Hex	Description
15	/	/	/
14:0	R/W	0x0000	Left attack time coefficient setting 0000: 1x32/fs 0001: 2x32/fs ----- 7FFF: 2 ¹⁵ x32/fs T=(n+1)*32/fs When the gain decreases, the actual gain will decrease 0.5dB at every attack time.

3.20.5.70. 0x430 ADC DAP Right Decay Time Register(Default Value: 0x0000001F)

Offset: 0x430			Register Name: AC_ADC_DAPRDT
Bit	R/W	Default/Hex	Description

15	/	/	/
14:0	R/W	0x001F (32x32fs)	<p>Right decay time coefficient setting</p> <p>0000: 1x32/fs</p> <p>0001: 2x32/fs</p> <p>-----</p> <p>7FFF: 2¹⁵ x32/fs</p> <p>T=(n+1)*32/fs</p> <p>When the gain increases, the actual gain will increase 0.5dB at every decay time.</p>

3.20.5.71. 0x434 ADC DAP Right Attack Time Register(Default Value: 0x00000000)

Offset: 0x434			Register Name: AC_ADC_DAPRDT
Bit	R/W	Default/Hex	Description
15	/	/	/
14:0	R/W	0x0000	<p>Right attack time coefficient setting</p> <p>0000: 1x32/fs</p> <p>0001: 2x32/fs</p> <p>-----</p> <p>7FFF: 2¹⁵ x32/fs</p> <p>T=(n+1)*32/fs</p> <p>When the gain decreases, the actual gain will decrease 0.5dB at every attack time.</p>

3.20.5.72. 0x438 ADC DAP Noise Threshold Register(Default Value: 0x00001E1E)

Offset: 0x438			Register Name: AC_ADC_DAPNTH
Bit	R/W	Default/Hex	Description
15:13	/	/	/
12:8	R/W	0x1E (-90dB)	<p>Left channel noise threshold setting.</p> <p>0x00: -30dB</p> <p>0x01: -32dB</p> <p>0x02: -34dB</p> <p>-----</p> <p>0x1D: -88dB</p> <p>0x1E: -90dB</p> <p>0x1F: -90dB(the same as 0x1E)</p>
7:5	/	/	/
4:0	R/W	0x1E(-90dB)	<p>Right channel noise threshold setting(-90 -- -30dB).</p> <p>0x00: -30dB</p> <p>0x01: -32dB</p> <p>0x02: -34dB</p>

			----- 0x1D: -88dB 0x1E: -90dB 0x1F: -90dB(the same as 0x1E)
--	--	--	--

3.20.5.73. 0x43C ADC DAP Left Input Signal High Average Coef Register(Default Value: 0x00000005)

Offset: 0x43C			Register Name: AC_ADC_DAPLHNAC
Bit	R/W	Default/Hex	Description
15:11	/	/	/
10:0	R/W	0x0005	Left input signal average filter coefficient to check noise or not(the coefficient [reg0f[10:0],reg10] is 3.24 format 2s complement), always the same as the left output signal average filter's.

3.20.5.74. 0x440 ADC DAP Left Input Signal Low Average Coef Register(Default Value: 0x00001EB8)

Offset: 0x440			Register Name: AC_ADC_DAPLHNAC
Bit	R/W	Default/Hex	Description
15:0	R/W	0x1EB8	Left input signal average filter coefficient to check noise or not(the coefficient [reg0f[10:0],reg10] is 3.24 format 2s complement) always the same as the left output signal average filter's

3.20.5.75. 0x444 ADC DAP Right Input Signal High Average Coef Register(Default Value: 0x00000005)

Offset: 0x444			Register Name: AC_ADC_DAPRHNAC
Bit	R/W	Default/Hex	Description
15:11	/	/	/
10:0	R/W	0x0005	Right input signal average filter coefficient to check noise or not(the coefficient [reg11[10:0],reg12] is 3.24 format 2s complement), always the same as the right output signal average filter's

3.20.5.76. 0x448 ADC DAP Right Input Signal Low Average Coef Register(Default Value: 0x00001EB8)

Offset: 0x448			Register Name: AC_ADC_DAPRHNAC
Bit	R/W	Default/Hex	Description
15:0	R/W	0x1EB8	Right input signal average filter coefficient to check noise or not(the coefficient [reg11[10:0],reg12] is 3.24 format 2s complement), always the same as the right output signal average filter's

3.20.5.77. 0x44C ADC DAP High HPF Coef Register(Default Value: 0x000000FF)

Offset: 0x44C			Register Name: AC_DAPHPFC
Bit	R/W	Default/Hex	Description
15:11	/	/	/
10:0	R/W	0x00FF	HPF coefficient setting(the coefficient [reg13[10:0],reg14] is 3.24 format 2s complement)

3.20.5.78. 0x450 ADC DAP Low HPF Coef Register(Default Value: 0x0000FAC1)

Offset: 0x450			Register Name: AC_DAPLHPFC
Bit	R/W	Default/Hex	Description
15:0	R/W	0xFAC1	HPF coefficient setting(the coefficient [reg13[10:0],reg14] is 3.24 format 2s complement)

3.20.5.79. 0x454 ADC DAP Optimum Register(Default Value: 0x00000000)

Offset: 0x454			Register Name: AC_DAPOPT
Bit	R/W	Default/Hex	Description
15:11	/	/	/
10	R/W	0	Left energy default value setting(include the input and output) 0: min 1: max
9:8	R/W	00	Left channel gain hysteresis setting. The different between target level and the signal level must larger than the hysteresis when the gain change. 00: 0.4375db 01: 0.9375db 10: 1.9375db 11: 3db
7:6	/	/	/
5	R/W	0	The input signal average filter coefficient setting 0: is the [reg0f[10:0], reg10] and [reg11[1:0], reg12]; 1: is the [reg06[10:0], reg07] and [reg08[1:0], reg09];
4	R/W	0	AGC output when the channel in noise state 0: output is zero 1: output is the input data
3	/	/	/
2	R/W	0	Right energy default value setting(include the input and output)

			0: min 1: max
1:0	R/W	00	Right channel gain hysteresis setting. The difference between target level and the signal level must be larger than the hysteresis when the gain changes. 00: 0.4375db 01: 0.9375db 10: 1.9375db 11: 3db

3.20.5.80. 0x480 DAC DAP Control Register(Default Value: 0x00000000)

Offset: 0x480			Register Name: AC_DAC_DAPCTRL
Bit	R/W	Default/Hex	Description
15:7	/	/	/
6	R/W	0	DRC1 enable control 0: disable 1: enable
5	R/W	0	DRC1 Left channel HPF enable control 0: disable 1: enable
4	R/W	0	DRC1 Right channel HPF enable control 0: disable 1: enable
3	/	/	/
2	R/W	0	DRC0 enable control 0: disable 1: enable
1	R/W	0	DRC0 Left channel HPF enable control 0: disable 1: enable
0	R/W	0	DRC0 Right channel HPF enable control 0: disable 1: enable

3.20.5.81. 0x4D0 AGC Enable Register(Default Value: 0x00000000)

Offset: 0x4D0			Register Name: AGC_ENA
Bit	R/W	Default/Hex	Description
15	R/W	0x0	AIF1_ADC0L_AGC_ENA AIF1 ADC timeslot 0 left channel AGC enable 0: Disable 1: Enable
14	R/W	0x0	AIF1_ADC0R_AGC_ENA AIF1 ADC timeslot 0 right channel AGC enable 0: Disable 1: Enable

13	R/W	0x0	AIF1_ADC1L_AGC_ENA AIF1 ADC timeslot 1 left channel AGC enable 0: Disable 1: Enable
12	R/W	0x0	AIF1_ADC1R_AGC_ENA AIF1 ADC timeslot 1 right channel AGC enable 0: Disable 1: Enable
11	R/W	0x0	AIF2_ADCL_AGC_ENA AIF2 ADC left channel AGC enable 0: Disable 1: Enable
10	R/W	0x0	AIF2_ADCR_AGC_ENA AIF2 ADC right channel AGC enable 0: Disable 1: Enable
9	R/W	0x0	AIF2_DACL_AGC_ENA AIF2 DAC left channel AGC enable 0: Disable 1: Enable
8	R/W	0x0	AIF2_DACR_AGC_ENA AIF2 DAC right channel AGC enable 0: Disable 1: Enable
7	R/W	0x0	ADCL_AGC_ENA ADC left channel AGC enable 0: Disable 1: Enable
6	R/W	0x0	ADCR_AGC_ENA ADC right channel AGC enable 0: Disable 1: Enable
5:0	R/W	0x0	Reserved

3.20.5.82. 0x4D4 DRC Enable Register(Default Value: 0x00000000)

Offset: 0x4D4			Register Name: DRC_ENA
Bit	R/W	Default/Hex	Description
15	R/W	0x0	AIF1_DAC0_DRC0_ENA AIF1 DAC timeslot 0 DRC0 enable 0: Disable 1: Enable
14	R/W	0x0	AIF1_DAC1_DRC0_ENA

			AIF1 DAC timeslot 1 DRC0 enable 0: Disable 1: Enable
13	R/W	0x0	AIF2_DAC_DRC0_ENA AIF2 DAC DRC0 enable 0: Disable 1: Enable
12	R/W	0x0	DAC_DRC0_ENA DAC DRC0 enable 0: Disable 1: Enable
11:8	/	/	/
7	R/W	0x0	AIF1_ADC0_DRC1_ENA AIF1 ADC timeslot 0 DRC1 enable 0 : Disable 1 : Enable
6	R/W	0x0	AIF1_ADC1_DRC1_ENA AIF1 ADC timeslot 1 DRC1 enable 0 : Disable 1 : Enable
5	R/W	0x0	AIF2_ADC_DRC1_ENA AIF2 ADC DRC1 enable 0 : Disable 1 : Enable
4	R/W	0x0	ADC_DRC1_ENA ADC_DRC1 enable 0 : Disable 1 : Enable
3:0	/	/	/

3.20.5.83. 0x4D8 SRC Bist Control Register(Default Value: 0x00000000)

Offset: 0x4D8			Register Name: SRC_BISTCR
Bit	R/W	Default/Hex	Description
15:13	R/W	0	SRC1 and SRC2 SRAM BIST Register Select
12	R/W	0	SRC1 and SRC2 SRAM BIST Address MODE Select
11:9	R/W	0	SRC1 and SRC2 SRAM BIST Write Data Pattern 0: 0x0000_0000 1: 0x5555_5555 2: 0x3333_3333 3: 0x0f0f_0f0f 4: 0x00ff_00ff 5: 0x0000_ffff

			Others, reserved.
8	R/W	0	SRC1 and SRC2 SRAM BIST Enable A positive edge will trigger the SRAM BIST to start
7	R	0	SRC2 ROM CheckSum Error 0: No Error 1: Error
6	R	0	SRC2 ROM CheckXor Error 0: No Error 1: Error
5	R	0	SRC2 ROM BIST Busy 0: Idle 1: Busy
4	R/W	0	SRC2 ROM BIST Enable A positive edge will trigger the ROM BIST to start
3	R	0	SRC1 ROM CheckSum Error 0: No Error 1: Error
2	R	0	SRC1 ROM CheckXor Error 0: No Error 1: Error
1	R	0	SRC1 ROM BIST Busy 0: Idle 1: Busy
0	R/W	0	SRC1 ROM BIST Enable A positive edge will trigger the ROM BIST to start

3.20.5.84. 0x4DC SRC Bist Status Register(Default Value: 0x0000202)

Offset: 0x4DC			Register Name: SRC_BISTST
Bit	R/W	Default/Hex	Description
15	R	0	SRC2 SRAM BIST Error Status 0: No Error 1: Error
14:12	R	0	SRC2 SRAM BIST Error Pattern
11:10	R	0	SRC2 SRAM BIST Error Cycles
9	R	1	SRC2 SRAM BIST Stop 0: Running 1: Stop
8	R	0	SRC2 SRAM BIST Busy 0: Idle 1: Busy
7	R	0	SRC1 SRAM BIST Error Status 0: No Error 1: Error
6:4	R	0	SRC1 SRAM BIST Error Pattern
3:2	R	0	SRC1 SRAM BIST Error Cycles
1	R	1	SRC1 SRAM BIST Stop 0: Running 1: Stop
0	R	0	SRC1 SRAM BIST Busy 0: Idle 1: Busy

3.20.5.85. 0x4E0 SRC1 Control 1 Register(Default Value: 0x00000000)

Offset: 0x4E0			Register Name: SRC1_CTRL1
Bit	R/W	Default/Hex	Description
15	R/W	0x0	SRC1_RATI_ENA SRC1 Manual setting ratio enable 0-disable 1-enable
14	R	0x0	SRC1_LOCK_STS SRC1 Ratio lock status 0-not locked 1-locked
13	R	0x0	SRC1_FIFO_OVR SRC1 FIFO Overflow status 0-normal 1-overflowed
12:10	R	0x0	SRC1_FIFO_LEV_[8:6] SRC1 FIFO Level high 3-bit
9:0	R/W	0x0	SRC1_RATI_SET_[25:16] Manual setting ratio high 10-bit

3.20.5.86. 0x4E4 SRC1 Control 2 Register(Default Value: 0x00000000)

Offset: 0x4E4			Register Name: SRC1_CTRL2
Bit	R/W	Default/Hex	Description
15:0	R/W	0x0	SRC1_RATI_SET_[15:0] Manual setting ratio low 16-bit

3.20.5.87. 0x4E8 SRC1 Control 3 Register(Default Value: 0x00000040)

Offset: 0x4E8			Register Name: SRC1_CTRL3
Bit	R/W	Default/Hex	Description
15:10	R	0x0	SRC1_FIFO_LEV_[5:0] SRC1 FIFO Level low 6-bit
9:0	R	0x40	SRC1_RATI_VAL_[25:16] Calculated ratio high 10-bit

3.20.5.88. 0x4EC SRC1 Control 4 Register(Default Value: 0x00000000)

Offset: 0x4EC			Register Name: SRC1_CTRL4
Bit	R/W	Default/Hex	Description
15:0	R	0x0	SRC1_RATI_VAL_[15:0] Calculated ratio low 16-bit

3.20.5.89. 0x4F0 SRC2 Control 1 Register(Default Value: 0x00000000)

Offset: 0x4F0			Register Name: SRC2_CTRL1
Bit	R/W	Default/Hex	Description
15	R/W	0x0	SRC2_RATI_ENA SRC2 Manual setting ratio enable 0-disable 1-enable
14	R	0x0	SRC2_LOCK_STS SRC2 Ratio lock status 0-not locked 1-locked
13	R	0x0	SRC2_FIFO_OVR SRC2 FIFO Overflow status 0-normal 1-overflowed
12:10	R	0x0	SRC2_FIFO_LEV_[8:6] SRC2 FIFO Level high 3-bit
9:0	R/W	0x0	SRC2_RATI_SET_[25:16] Manual setting ratio high 10-bit

3.20.5.90. 0x4F4 SRC2 Control 2 Register(Default Value: 0x00000000)

Offset: 0x4F4			Register Name: SRC2_CTRL2
Bit	R/W	Default/Hex	Description
15:0	R/W	0x0	SRC2_RATI_SET_[15:0] Manual setting ratio low 16-bit

3.20.5.91. 0x4F8 SRC2 Control 3 Register(Default Value: 0x00000040)

Offset: 0x4F8			Register Name: SRC2_CTRL3
Bit	R/W	Default/Hex	Description
15:10	R	0x0	SRC2_FIFO_LEV_[5:0] SRC2 FIFO Level low 6-bit
9:0	R	0x40	SRC2_RATI_VAL_[25:16] Calculated ratio high 10-bit

3.20.5.92. 0x4FC SRC2 Control 4 Register(Default Value: 0x00000000)

Offset: 0x4FC			Register Name: SRC2_CTRL4
---------------	--	--	----------------------------------

Bit	R/W	Default/Hex	Description
15:0	R	0x0	SRC2_RATI_VAL_[15:0] Calculated ratio low 16-bit

3.20.5.93. 0x600 DRC0 High HPF Coef Register(Default Value: 0x000000FF)

Offset: 0x600			Register Name: AC_DRC0_HHPFC
Bit	R/W	Default/Hex	Description
15:11	/	/	/
10:0	R/W	0xFF	HPF coefficient setting and the data is 3.24 format.

3.20.5.94. 0x604 DRC0 Low HPF Coef Register(Default Value: 0x0000FAC1)

Offset: 0x604			Register Name: AC_DRC0_LHPFC
Bit	R/W	Default/Hex	Description
15:0	R/W	0xFAC1	HPF coefficient setting and the data is 3.24 format.

3.20.5.95. 0x608 DRC0 Control Register(Default Value: 0x00000080)

Offset: 0x608			Register Name: AC_DRC0_CTRL
Bit	R/W	Default/Hex	Description
15	R	0	DRC delay buffer data output state when drc delay function is enable and the drc function disable. After disable drc function and this bit go to 0, the user should write the drc delay function bit to 0; 0 : not complete 1 : is complete
14	/	/	/
13:8	R/W	0	Signal delay time setting 6'h00 : (8x1)fs 6'h01 : (8x2)fs 6'h02 : (8x3)fs ----- 6'h2e : (8*47)fs 6'h2f : (8*48)fs 6'h30 -- 6'h3f : (8*48)fs Delay time = 8*(n+1)fs, n<6'h30; When the delay function is disable, the signal delay time is unused.
7	R/W	0x1	The delay buffer use or not when the drc disable and the drc buffer data output completely 0 : don't use the buffer

			1 : use the buffer
6	R/W	0x0	DRC gain max limit enable 0 : disable 1 : enable
5	R/W	0x0	DRC gain min limit enable. when this fuction enable, it will overwrite the noise detect fuction. 0 : disable 1 : enable
4	R/W	0x0	Control the drc to detect noise when ET enable 0 : disable 1 : enable
3	R/W	0x0	Signal function Select 0 : RMS filter 1 : Peak filter When Signal function Select Peak filter, the RMS parameter is unused. (AC_DRC_LRMSHAT / AC_DRC_LRMSLAT / AC_DRC_LRMSHAT / AC_DRC_LRMSLAT) When Signal function Select RMS filter, the Peak filter parameter is unused.(AC_DRC_LPFHAT / AC_DRC_LPFLAT / AC_DRC_RPFHAT / AC_DRC_RPFLAT / AC_DRC_LPFHRT / AC_DRC_LPFLRT / AC_DRC_RPFHRT / AC_DRC_RPFLRT)
2	R/W	0x0	Delay function enable 0 : disable 1 : enable When the Delay function enable is disable, the Signal delay time is unused.
1	R/W	0x0	DRC LT enable 0 : disable 1 : enable When the DRC LT is disable the LT, KI and OPL parameter is unused.
0	R/W	0x0	DRC ET enable 0 : disable 1 : enable When the DRC ET is disable the ET, Ke and OPE parameter is unused.

3.20.5.96. 0x60C DRC0 Left Peak Filter High Attack Time Coef Register(Default Value: 0x0000000B)

Offset: 0x60C			Register Name: AC_DRC0_LPFHAT
Bit	R/W	Default/Hex	Description
15:11	/	/	/
10:0	R/W	0x000B	The left peak filter attack time parameter setting, which determine by the equation that $AT = 1 - \exp(-2.2Ts/ta)$. The format is 3.24. (1ms)

3.20.5.97. 0x610 DRC0 Left Peak Filter Low Attack Time Coef Register(Default Value: 0x000077BF)

Offset: 0x610			Register Name: AC_DRC0_LPFLAT
Bit	R/W	Default/Hex	Description
15:0	R/W	0x77BF	The left peak filter attack time parameter setting, which determine by the equation that $AT = 1 - \exp(-2.2Ts/ta)$. The format is 3.24. (1ms)

3.20.5.98. 0x614 DRC0 Right Peak Filter High Attack Time Coef Register(Default Value: 0x0000000B)

Offset: 0x614			Register Name: AC_DRC0_RPFHAT
Bit	R/W	Default/Hex	Description
15:11	/	/	/
10:0	R/W	0x000B	The left peak filter attack time parameter setting, which determine by the equation that $AT = 1 - \exp(-2.2Ts/ta)$. The format is 3.24. (1ms)

3.20.5.99. 0x618 DRC0 Peak Filter Low Attack Time Coef Register(Default Value: 0x000077BF)

Offset: 0x618			Register Name: AC_DRC0_RPFLAT
Bit	R/W	Default/Hex	Description
15:0	R/W	0x77BF	The left peak filter attack time parameter setting, which determine by the equation that $AT = 1 - \exp(-2.2Ts/ta)$. The format is 3.24. (1ms)

3.20.5.100. 0x61C DRC0 Left Peak Filter High Release Time Coef Register(Default Value: 0x000000FF)

Offset: 0x61C			Register Name: AC_DRC0_LPFHRT
Bit	R/W	Default/Hex	Description
15:11	/	/	/
10:0	R/W	0x00FF	The left peak filter release time parameter setting, which determine by the equation that $RT = \exp(-2.2Ts/tr)$. The format is 3.24. (100ms)

3.20.5.101. 0x620 DRC0 Left Peak Filter Low Release Time Coef Register(Default Value: 0x0000E1F8)

Offset: 0x620			Register Name: AC_DRC0_LPFLRT
Bit	R/W	Default/Hex	Description
15:0	R/W	0xE1F8	The left peak filter release time parameter setting, which determine by the equation that $RT = \exp(-2.2Ts/tr)$. The format is 3.24. (100ms)

3.20.5.102. 0x624 DRC0 Right Peak filter High Release Time Coef Register(Default Value: 0x000000FF)

Offset: 0x624			Register Name: AC_DRC0_RPFHRT
Bit	R/W	Default/Hex	Description
15:11	/	/	/
10:0	R/W	0x00FF	The left peak filter attack time parameter setting, which determine by the equation that $RT = \exp(-2.2Ts/tr)$. The format is 3.24. (100ms)

3.20.5.103. 0x628 DRC0 Right Peak filter Low Release Time Coef Register(Default Value: 0x0000E1F8)

Offset: 0x628			Register Name: AC_DRC0_RPFLRT
Bit	R/W	Default/Hex	Description
15:0	R/W	0xE1F8	The left peak filter release time parameter setting, which determine by the equation that $AT = \exp(-2.2Ts/tr)$. The format is 3.24. (100ms)

3.20.5.104. 0x62C DRC0 Left RMS Filter High Coef Register(Default Value: 0x00000001)

Offset: 0x62C			Register Name: AC_DRC0_LRMSHAT
Bit	R/W	Default/Hex	Description
15:11	/	/	/
10:0	R/W	0x0001	The left RMS filter average time parameter setting, which determine by the equation that $AT = 1 - \exp(-2.2Ts/tav)$. The format is 3.24. (10ms)

3.20.5.105. 0x630 DRC0 Left RMS Filter Low Coef Register(Default Value: 0x00002BAF)

Offset: 0x630			Register Name: AC_DRC0_LRMSLAT
Bit	R/W	Default/Hex	Description
15:0	R/W	0x2BAF	The left RMS filter average time parameter setting, which determine by the equation that $AT = 1 - \exp(-2.2Ts/tav)$. The format is 3.24. (10ms)

3.20.5.106. 0x634 DRC0 Right RMS Filter High Coef Register(Default Value: 0x00000001)

Offset: 0x634			Register Name: AC_DRC0_RRMSHAT
Bit	R/W	Default/Hex	Description
15:11	/	/	/
10:0	R/W	0x0001	The right RMS filter average time parameter setting, which determine by the equation that $AT = 1 - \exp(-2.2Ts/tav)$. The format is 3.24. (10ms)

3.20.5.107. 0x638 DRC0 Right RMS Filter Low Coef Register(Default Value: 0x00002BAF)

Offset: 0x638			Register Name: AC_DRC0_RRMSLAT
Bit	R/W	Default/Hex	Description
15:0	R/W	0x2BAF	The right RMS filter average time parameter setting, which determine by the equation that $AT = 1 - \exp(-2.2Ts/\tau_{av})$. The format is 3.24. (10ms)

3.20.5.108. 0x63C DRC0 Compressor Theshold High Setting Register(Default Value: 0x000006A4)

Offset: 0x63C			Register Name: AC_DRC0_HCT
Bit	R/W	Default/Hex	Description
15:0	R/W	0x06A4	The compressor threshold setting, which set by the equation that $CT_{in} = -CT/6.0206$. The format is 8.24 (-40dB)

3.20.5.109. 0x640 DRC0 Compressor Theshold Low Setting Register(Default Value: 0x0000D3C0)

Offset: 0x640			Register Name: AC_DRC0_LCT
Bit	R/W	Default/Hex	Description
15:0	R/W	0xD3C0	The compressor threshold setting, which set by the equation that $CT_{in} = -CT/6.0206$. The format is 8.24 (-40dB)

3.20.5.110. 0x644 DRC0 Compressor Slope High Setting Register(Default Value: 0x00000080)

Offset: 0x644			Register Name: AC_DRC0_HKC
Bit	R/W	Default/Hex	Description
15:13	/	/	/
13:0	R/W	0x0080	The slope of the compressor which determine by the equation that $K_c = 1/R$, there, R is the ratio of the compressor, which always is interger. The format is 8.24. (2 : 1)

3.20.5.111. 0x648 DRC0 Compressor Slope Low Setting Register(Default Value: 0x00000000)

Offset: 0x648			Register Name: AC_DRC0_LKC
Bit	R/W	Default/Hex	Description
15:0	R/W	0x0000	The slope of the compressor which determine by the equation that $K_c = 1/R$, there, R is the ratio of the compressor, which always is interger. The format is 8.24. (2 : 1)

3.20.5.112. 0x64C DRC0 Compressor High Output at Compressor Threshold Register(Default Value: 0x0000F95B)

Offset: 0x64C			Register Name: AC_DRC0_HOPC
Bit	R/W	Default/Hex	Description
15:0	R/W	0xF95B	The output of the compressor which determine by the equation $-OPC/6.0206$ The format is 8.24 (-40dB)

3.20.5.113. 0x650 DRC0 Compressor Low Output at Compressor Threshold Register(Default Value: 0x00002C3F)

Offset: 0x650			Register Name: AC_DRC0_LOPC
Bit	R/W	Default/Hex	Description
15:0	R/W	0x2C3F	The output of the compressor which determine by the equation $OPC/6.0206$ The format is 8.24 (-40dB)

3.20.5.114. 0x654 DRC0 Limiter Theshold High Setting Register(Default Value: 0x000001A9)

Offset: 0x654			Register Name: AC_DRC0_HLT
Bit	R/W	Default/Hex	Description
15:0	R/W	0x01A9	The limiter threshold setting, which set by the equation that $LT_{in} = -LT/6.0206$, The format is 8.24. (-10dB)

3.20.5.115. 0x658 DRC0 Limiter Theshold Low Setting Register(Default Value: 0x000034F0)

Offset: 0x658			Register Name: AC_DRC0_LLT
Bit	R/W	Default/Hex	Description
15:0	R/W	0x34F0	The limiter threshold setting, which set by the equation that $LT_{in} = -LT/6.0206$, The format is 8.24. (-10dB)

3.20.5.116. 0x65C DRC0 Limiter Slope High Setting Register(Default Value: 0x00000005)

Offset: 0x65C			Register Name: AC_DRC0_HK1
Bit	R/W	Default/Hex	Description
15:11	/	/	/
13:0	R/W	0x0005	The slope of the limiter which determine by the equation that $KI = 1/R$, there, R is the ratio of the limiter, which always is interger. The format is

			8.24. (50 :1)
--	--	--	---------------

3.20.5.117. 0x660 DRC0 Limiter Slope Low Setting Register(Default Value: 0x00001EB8)

Offset: 0x660			Register Name: AC_DRC0_LK1
Bit	R/W	Default/Hex	Description
15:0	R/W	0x1EB8	The slope of the limiter which determine by the equation that $KI = 1/R$, there, R is the ratio of the limiter, which always is interger. The format is 8.24. (50 :1)

3.20.5.118. 0x664 DRC0 Limiter High Output at Limiter Threshold Register(Default Value: 0x0000FBD8)

Offset: 0x664			Register Name: AC_DRC0_HOPL
Bit	R/W	Default/Hex	Description
15:0	R/W	0xFBD8	The output of the limiter which determine by equation $OPT/6.0206$. The format is 8.24 (-25dB)

3.20.5.119. 0x668 DRC0 Limiter Low Output at Limiter Threshold Register(Default Value: 0x0000FBA7)

Offset: 0x668			Register Name: AC_DRC0_LOPL
Bit	R/W	Default/Hex	Description
15:0	R/W	0xFBA7	The output of the limiter which determine by equation $OPT/6.0206$. The format is 8.24 (-25dB)

3.20.5.120. 0x66C DRC0 Expander Theshold High Setting Register(Default Value: 0x00000BA0)

Offset: 0x66C			Register Name: AC_DRC0_HET
Bit	R/W	Default/Hex	Description
15:0	R/W	0x0BA0	The expander threshold setting, which set by the equation that $ETin = -ET/6.0206$, The format is 8.24. (-70dB)

3.20.5.121. 0x670 DRC0 Expander Theshold Low Setting Register(Default Value: 0x00007291)

Offset: 0x670			Register Name: AC_DRC0_LET
Bit	R/W	Default/Hex	Description
15:0	R/W	0x7291	The expander threshold setting, which set by the equation that $ETin = -ET/6.0206$, The format is 8.24. (-70dB)

3.20.5.122. 0x674 DRC0 Expander Slope High Setting Register(Default Value: 0x00000500)

Offset: 0x674			Register Name: AC_DRC0_HKE
Bit	R/W	Default/Hex	Description
15:14	/	/	/
13:0	R/W	0x0050	The slope of the expander which determine by the equation that $K_e = 1/R$, there, R is the ratio of the expander, which always is interger and the ke must larger than 50. The format is 8.24. (1:5)

3.20.5.123. 0x678 DRC0 Expander Slope Low Setting Register(Default Value: 0x00000000)

Offset: 0x678			Register Name: AC_DRC0_LKE
Bit	R/W	Default/Hex	Description
15:0	R/W	0x0000	The slope of the expander which determine by the equation that $K_e = 1/R$, there, R is the ratio of the expander, which always is interger and the ke must larger than 50. The format is 8.24. (1:5)

3.20.5.124. 0x67C DRC0 Expander High Output at Expander Threshold Register(Default Value: 0x0000F45F)

Offset: 0x67C			Register Name: AC_DRC0_HOPE
Bit	R/W	Default/Hex	Description
15:0	R/W	0xF45F	The output of the expander which determine by equation $OPE/6.0206$. The format is 8.24 (-70dB)

3.20.5.125. 0x680 DRC0 Expander Low Output at Expander Threshold Register(Default Value: 0x00008D6E)

Offset: 0x680			Register Name: AC_DRC0_LOPE
Bit	R/W	Default/Hex	Description
15:0	R/W	0x8D6E	The output of the expander which determine by equation $OPE/6.0206$. The format is 8.24 (-70dB)

3.20.5.126. 0x684 DRC0 Linear Slope High Setting Register(Default Value: 0x00000100)

Offset: 0x684			Register Name: AC_DRC0_HKN
Bit	R/W	Default/Hex	Description
15:14	/	/	/
13:0	R/W	0x0100	The slope of the linear which determine by the equation that $K_n = 1/R$, there, R is the ratio of the linear, which always is interger . The format is 8.24. (1:1)

3.20.5.127. 0x688 DRC0 Linear Slope Low Setting Register(Default Value: 0x00000000)

Offset: 0x688			Register Name: AC_DRC0_LKN
Bit	R/W	Default/Hex	Description
15:0	R/W	0x0000	The slope of the linear which determine by the equation that $K_n = 1/R$, there, R is the ratio of the linear, which always is interger . The format is 8.24. (1:1)

3.20.5.128. 0x68C DRC0 Smooth filter Gain High Attack Time Coef Register(Default Value: 0x00000002)

Offset: 0x68C			Register Name: AC_DRC0_SFHAT
Bit	R/W	Default/Hex	Description
15:11	/	/	/
10:0	R/W	0x0002	The smooth filter attack time parameter setting, which determine by the equation that $AT = 1 - \exp(-2.2T_s/tr)$. The format is 3.24. (5ms)

3.20.5.129. 0x690 DRC0 Smooth filter Gain Low Attack Time Coef Register(Default Value: 0x00005600)

Offset: 0x690			Register Name: AC_DRC0_SFLAT
Bit	R/W	Default/Hex	Description
15:0	R/W	0x5600	The smooth filter attack time parameter setting, which determine by the equation that $AT = 1 - \exp(-2.2T_s/tr)$. The format is 3.24. (5ms)

3.20.5.130. 0x694 DRC0 Smooth filter Gain High Release Time Coef Register(Default Value: 0x00000000)

Offset: 0x694			Register Name: AC_DRC0_SFHRT
Bit	R/W	Default/Hex	Description
15:11	/	/	/
10:0	R/W	0x0000	The gain smooth filter release time parameter setting, which determine

			by the equation that $RT = 1 - \exp(-2.2T_s/tr)$. The format is 3.24. (200ms)
--	--	--	--

3.20.5.131. 0x698 DRC0 Smooth filter Gain Low Release Time Coef Register(Default Value: 0x0000F04)

Offset: 0x698			Register Name: AC_DRC0_SFHRT
Bit	R/W	Default/Hex	Description
15:0	R/W	0x0F04	The gain smooth filter release time parameter setting, which determine by the equation that $RT = 1 - \exp(-2.2T_s/tr)$. The format is 3.24. (200ms)

3.20.5.132. 0x69C DRC0 MAX Gain High Setting Register(Default Value: 0x0000FE56)

Offset: 0x69C			Register Name: AC_DRC0_MXGHS
Bit	R/W	Default/Hex	Description
15:0	R/W	0xFE56	The max gain setting which determine by equation $MXG/6.0206$. The format is 8.24 and must $-20dB < MXG < 30dB$ (-10dB)

3.20.5.133. 0x6A0 DRC0 MAX Gain Low Setting Register(Default Value: 0x0000CB0F)

Offset: 0x6A0			Register Name: AC_DRC0_MXGLS
Bit	R/W	Default/Hex	Description
15:0	R/W	0xCB0F	The max gain setting which determine by equation $MXG/6.0206$. The format is 8.24 and must $-20dB < MXG < 30dB$ (-10dB)

3.20.5.134. 0x6A4 DRC0 MIN Gain High Setting Register(Default Value: 0x0000F95B)

Offset: 0x6A4			Register Name: AC_DRC0_MNGHS
Bit	R/W	Default/Hex	Description
15:0	R/W	0xF95B	The min gain setting which determine by equation $MXG/6.0206$. The format is 8.24 and must $-60dB \leq MNG \leq -40dB$ (-40dB)

3.20.5.135. 0x6A8 DRC0 MIN Gain Low Setting Register(Default Value: 0x00002C3F)

Offset: 0x6A8			Register Name: AC_DRC0_MNGLS
Bit	R/W	Default/Hex	Description
15:0	R/W	0x2C3F	The min gain setting which determine by equation $MNG/6.0206$. The format is 8.24 and must $-60dB \leq MNG \leq -40dB$ (-40dB)

3.20.5.136. 0x6AC DRC0 Expander Smooth Time High Coef Register(Default Value: 0x00000000)

Offset: 0x6AC			Register Name: AC_DRC0_EPSHC
Bit	R/W	Default/Hex	Description
11:0	R/W	0x0000	The gain smooth filter release and attack time parameter setting in expander region, which determine by the equation that $RT = 1 - \exp(-2.2T_s/tr)$. The format is 3.24. (30ms)

3.20.5.137. 0x6B0 DRC0 Expander Smooth Time Low Coef Register(Default Value: 0x0000640C)

Offset: 0x6B0			Register Name: AC_DRC0_EPSLC
Bit	R/W	Default/Hex	Description
15:0	R/W	0x640C	The gain smooth filter release and attack time parameter setting in expander region, which determine by the equation that $RT = 1 - \exp(-2.2T_s/tr)$. The format is 3.24. (30ms)

3.20.5.138. 0x6B4 DRC0 Optimum Register(Default Value: 0x00000000)

Offset: 0x6B4			Register Name: AC_DRC0_OPT
Bit	R/W	Default/Hex	Description
15:11	/	/	/
10	R/W	0x0	The gain smooth use the expander coefficient when the energy in expander range 0 : use the normal smooth coefficient 1 : use the expander coefficient
9	R/W	0x0	The gain normal smooth coefficient selection mode set 0 : both release and attack coefficient use hysteresis; 1 : only the attack coefficient use hysteresis;
8	R/W	0x0	The min of energy set in Peak detect mode 0 : -120dB 1 : -210dB
7	R/W	0x0	The energy mode select in rms detect mode 0 : the energy is RMS 1 : the energy is square of RMS
6	R/W	0x0	DRC data output when DRC disable and DRC delay data output complete. 0 : the output is the input music data; 1 : the output is 0 ;
5	R/W	0	DRC gain default value setting 0: The default gain is 1 1: The default gain is 0
4:0	R/W	0x00	The hysteresis of the gain smooth filter to use the decay time coefficient or the attack time coefficient.

			<p>When in the decay time state, if $g(n-1)-g(n)>hysteresis$, then the state will change to attack time state, and when in the attack time, if $g(n)-g(n-1)>hysteresis$, then the state will change to decay time state. Note the hysteresis of 0x00 and 0x04 is the same.</p> <p>00000: 2^{-16}</p> <p>00001: 2^{-19}</p> <p>00010: 2^{-18}</p> <p>00011: 2^{-17}</p> <p>00100: 2^{-16}</p> <p>-----</p> <p>10011: 2^{-1}</p> <p>10100 ~11111: 1</p> <p>$hysteresis = 2^{n-20}$, except $n=0x00$, and n less 0x14.</p>
--	--	--	--

3.20.5.139. 0x6B8 DRC0 HPF Gain High Coef Register(Default Value: 0x00000100)

Offset: 0x6B8			Register Name: AC_DRC0_HPFHGAIN
Bit	R/W	Default/Hex	Description
15:11	/	/	/
10:0	R/W	0x0100	The gain of the hpf coefficient setting which format is 3.24.(gain = 1)

3.20.5.140. 0x6BC DRC0 HPF Gain Low Coef Register(Default Value: 0x00000000)

Offset: 0x6BC			Register Name: AC_DRC0_HPFLGAIN
Bit	R/W	Default/Hex	Description
15:0	R/W	0x0000	The gain of the hpf coefficient setting which format is 3.24.(gain = 1)

3.20.5.141. 0x700 DRC1 High HPF Coef Register(Default Value: 0x000000FF)

Offset: 0x700			Register Name: AC_DRC1_HHPFC
Bit	R/W	Default/Hex	Description
15:11	/	/	/
10:0	R/W	0xFF	HPF coefficient setting and the data is 3.24 format.

3.20.5.142. 0x704 DRC1 Low HPF Coef Register(Default Value: 0x0000FAC1)

Offset: 0x704			Register Name: AC_DRC1_LHPFC
Bit	R/W	Default/Hex	Description
15:0	R/W	0xFAC1	HPF coefficient setting and the data is 3.24 format.

3.20.5.143. 0x708 DRC1 Control Register(Default Value: 0x00000080)

Offset: 0x708			Register Name: AC_DRC1_CTRL
Bit	R/W	Default/Hex	Description
15	R	0	DRC delay buffer data output state when drc delay function is enable and the drc function disable. After disable drc function and this bit go to 0, the user should write the drc delay function bit to 0; 0 : not complete 1 : is complete
14:10	/	/	/
13:8	R/W	0	Signal delay time setting 6'h00 : (8x1)fs 6'h01 : (8x2)fs 6'h02 : (8x3)fs ----- 6'h2e : (8*47)fs 6'h2f : (8*48)fs 6'h30 -- 6'h3f : (8*48)fs Delay time = 8*(n+1)fs, n<6'h30; When the delay function is disable, the signal delay time is unused.
7	R/W	0x1	The delay buffer use or not when the drc disable and the drc buffer data output completely 0 : don't use the buffer 1 : use the buffer
6	R/W	0x0	DRC gain max limit enable 0 : disable 1 : enable
5	R/W	0x0	DRC gain min limit enable. when this function enable, it will overwrite the noise detect function. 0 : disable 1 : enable
4	R/W	0x0	Control the drc to detect noise when ET enable 0 : disable 1 : enable

3	R/W	0x0	<p>Signal function Select</p> <p>0 : RMS filter</p> <p>1 : Peak filter</p> <p>When Signal function Select Peak filter, the RMS parameter is unused. (AC_DRC_LRMSHAT / AC_DRC_LRMSLAT / AC_DRC_LRMSHAT / AC_DRC_LRMSLAT)</p> <p>When Signal function Select RMS filter, the Peak filter parameter is unused.(AC_DRC_LPFHAT / AC_DRC_LPFLAT / AC_DRC_RPFHAT / AC_DRC_RPFLAT / AC_DRC_LPFHRT / AC_DRC_LPFLRT / AC_DRC_RPFHRT / AC_DRC_RPFLRT)</p>
2	R/W	0x0	<p>Delay function enable</p> <p>0 : disable</p> <p>1 : enable</p> <p>When the Delay function enable is disable, the Signal delay time is unused.</p>
1	R/W	0x0	<p>DRC LT enable</p> <p>0 : disable</p> <p>1 : enable</p> <p>When the DRC LT is disable the LT, KI and OPL parameter is unused.</p>
0	R/W	0x0	<p>DRC ET enable</p> <p>0 : disable</p> <p>1 : enable</p> <p>When the DRC ET is disable the ET, Ke and OPE parameter is unused.</p>

3.20.5.144. 0x70C DRC1 Left Peak Filter High Attack Time Coef Register(Default Value: 0x0000000B)

Offset: 0x70C			Register Name: AC_DRC1_LPFHAT
Bit	R/W	Default/Hex	Description
15:11	/	/	/
10:0	R/W	0x000B	The left peak filter attack time parameter setting, which determine by the equation that $AT = 1 - \exp(-2.2T_s/ta)$. The format is 3.24. (1ms)

3.20.5.145. 0x710 DRC1 Left Peak Filter Low Attack Time Coef Register(Default Value: 0x000077BF)

Offset: 0x710			Register Name: AC_DRC1_LPFLAT
Bit	R/W	Default/Hex	Description
15:0	R/W	0x77BF	The left peak filter attack time parameter setting, which determine by the equation that $AT = 1 - \exp(-2.2T_s/ta)$. The format is 3.24. (1ms)

3.20.5.146. 0x714 DRC1 Right Peak Filter High Attack Time Coef Register(Default Value: 0x0000000B)

Offset: 0x714			Register Name: AC_DRC1_RPFHAT
Bit	R/W	Default/Hex	Description
15:11	/	/	/
10:0	R/W	0x000B	The left peak filter attack time parameter setting, which determine by the equation that $AT = 1 - \exp(-2.2T_s/ta)$. The format is 3.24. (1ms)

3.20.5.147. 0x718 DRC1 Peak Filter Low Attack Time Coef Register(Default Value: 0x000077BF)

Offset: 0x718			Register Name: AC_DRC1_RPFLAT
Bit	R/W	Default/Hex	Description
15:0	R/W	0x77BF	The left peak filter attack time parameter setting, which determine by the equation that $AT = 1 - \exp(-2.2T_s/ta)$. The format is 3.24. (1ms)

3.20.5.148. 0x71C DRC1 Left Peak Filter High Release Time Coef Register(Default Value: 0x000000FF)

Offset: 0x71C			Register Name: AC_DRC1_LPFHRT
Bit	R/W	Default/Hex	Description
15:11	/	/	/
10:0	R/W	0x00FF	The left peak filter release time parameter setting, which determine by the equation that $RT = \exp(-2.2T_s/tr)$. The format is 3.24. (100ms)

3.20.5.149. 0x720 DRC1 Left Peak Filter Low Release Time Coef Register(Default Value: 0x0000E1F8)

Offset: 0x720			Register Name: AC_DRC1_LPFLRT
Bit	R/W	Default/Hex	Description
15:0	R/W	0xE1F8	The left peak filter release time parameter setting, which determine by the equation that $RT = \exp(-2.2T_s/tr)$. The format is 3.24. (100ms)

3.20.5.150. 0x724 DRC1 Right Peak filter High Release Time Coef Register(Default Value: 0x000000FF)

Offset: 0x724			Register Name: AC_DRC1_RPFHRT
Bit	R/W	Default/Hex	Description
15:11	/	/	/
10:0	R/W	0x00FF	The left peak filter attack time parameter setting, which determine by the equation that $RT = \exp(-2.2T_s/tr)$. The format is 3.24. (100ms)

3.20.5.151. 0x728 DRC1 Right Peak filter Low Release Time Coef Register(Default Value: 0x0000E1F8)

Offset: 0x728			Register Name: AC_DRC1_RPFLRT
Bit	R/W	Default/Hex	Description
15:0	R/W	0xE1F8	The left peak filter release time parameter setting, which determine by the equation that $AT = \exp(-2.2Ts/tr)$. The format is 3.24. (100ms)

3.20.5.152. 0x72C DRC Left RMS Filter High Coef Register(Default Value: 0x00000001)

Offset: 0x72C			Register Name: AC_DRC1_LRMSHAT
Bit	R/W	Default/Hex	Description
15:11	/	/	/
10:0	R/W	0x0001	The left RMS filter average time parameter setting, which determine by the equation that $AT = 1-\exp(-2.2Ts/tav)$. The format is 3.24. (10ms)

3.20.5.153. 0x730 DRC1 Left RMS Filter Low Coef Register(Default Value: 0x00002BAF)

Offset: 0x730			Register Name: AC_DRC1_LRMSLAT
Bit	R/W	Default/Hex	Description
15:0	R/W	0x2BAF	The left RMS filter average time parameter setting, which determine by the equation that $AT = 1-\exp(-2.2Ts/tav)$. The format is 3.24. (10ms)

3.20.5.154. 0x734 DRC1 Right RMS Filter High Coef Register(Default Value: 0x00000001)

Offset: 0x734			Register Name: AC_DRC1_RRMSHAT
Bit	R/W	Default/Hex	Description
15:11	/	/	/
10:0	R/W	0x0001	The right RMS filter average time parameter setting, which determine by the equation that $AT = 1-\exp(-2.2Ts/tav)$. The format is 3.24. (10ms)

3.20.5.155. 0x738 DRC1 Right RMS Filter Low Coef Register(Default Value: 0x00002BAF)

Offset: 0x738			Register Name: AC_DRC1_RRMSLAT
Bit	R/W	Default/Hex	Description
15:0	R/W	0x2BAF	The right RMS filter average time parameter setting, which determine by the equation that $AT = 1-\exp(-2.2Ts/tav)$. The format is 3.24. (10ms)

3.20.5.156. 0x73C DRC1 Compressor Theshold High Setting Register(Default Value: 0x000006A4)

Offset: 0x73C			Register Name: AC_DRC1_HCT
Bit	R/W	Default/Hex	Description
15:0	R/W	0x06A4	The compressor threshold setting, which set by the equation that $CT_{in} = -CT/6.0206$. The format is 8.24 (-40dB)

3.20.5.157. 0x740 DRC1 Compressor Slope High Setting Register(Default Value: 0x0000D3D0)

Offset: 0x740			Register Name: AC_DRC1_LCT
Bit	R/W	Default/Hex	Description
15:0	R/W	0xD3C0	The compressor threshold setting, which set by the equation that $CT_{in} = -CT/6.0206$. The format is 8.24 (-40dB)

3.20.5.158. 0x744 DRC1 Compressor Slope High Setting Register(Default Value: 0x00000080)

Offset: 0x744			Register Name: AC_DRC1_HKC
Bit	R/W	Default/Hex	Description
15:14	/	/	/
13:0	R/W	0x0800	The slope of the compressor which determine by the equation that $K_c = 1/R$, there, R is the ratio of the compressor, which always is interger. The format is 8.24. (2 : 1)

3.20.5.159. 0x748 DRC1 Compressor Slope Low Setting Register(Default Value: 0x00000000)

Offset: 0x748			Register Name: AC_DRC1_LKC
Bit	R/W	Default/Hex	Description
15:0	R/W	0x0000	The slope of the compressor which determine by the equation that $K_c = 1/R$, there, R is the ratio of the compressor, which always is interger. The format is 8.24. (2 : 1)

3.20.5.160. 0x74C DRC1 Compressor High Output at Compressor Threshold Register(Default Value: 0x0000F95B)

Offset: 0x74C			Register Name: AC_DRC1_HOPC
Bit	R/W	Default/Hex	Description
15:0	R/W	0xF95B	The output of the compressor which determine by the equation

			-OPC/6.0206 The format is 8.24 (-40dB)
--	--	--	--

3.20.5.161. 0x750 DRC1 Compressor Low Output at Compressor Threshold Register(Default Value: 0x00002C3F)

Offset: 0x750			Register Name: AC_DRC1_LOPC
Bit	R/W	Default/Hex	Description
15:0	R/W	0x2C3F	The output of the compressor which determine by the equation OPC/6.0206 The format is 8.24 (-40dB)

3.20.5.162. 0x754 DRC1 Limiter Theshold High Setting Register(Default Value: 0x00001A9)

Offset: 0x754			Register Name: AC_DRC1_HLT
Bit	R/W	Default/Hex	Description
15:0	R/W	0x01A9	The limiter threshold setting, which set by the equation that LTin = -LT/6.0206, The format is 8.24. (-10dB)

3.20.5.163. 0x758 DRC1 Limiter Theshold Low Setting Register(Default Value: 0x000034F0)

Offset: 0x758			Register Name: AC_DRC1_LLT
Bit	R/W	Default/Hex	Description
15:0	R/W	0x34F0	The limiter threshold setting, which set by the equation that LTin = -LT/6.0206, The format is 8.24. (-10dB)

3.20.5.164. 0x75C DRC1 Limiter Slope High Setting Register(Default Value: 0x00000005)

Offset: 0x75C			Register Name: AC_DRC1_HK1
Bit	R/W	Default/Hex	Description
15:11	/	/	/
13:0	R/W	0x0005	The slope of the limiter which determine by the equation that KI = 1/R, there, R is the ratio of the limiter, which always is interger. The format is 8.24. (50 :1)

3.20.5.165. 0x760 DRC1 Limiter Slope Low Setting Register(Default Value: 0x00001EB8)

Offset: 0x760			Register Name: AC_DRC1_LK1
---------------	--	--	-----------------------------------

Bit	R/W	Default/Hex	Description
15:0	R/W	0x1EB8	The slope of the limiter which determine by the equation that $KI = 1/R$, there, R is the ratio of the limiter, which always is interger. The format is 8.24. (50 :1)

3.20.5.166. 0x764 DRC1 Limiter High Output at Limiter Threshold Register(Default Value: 0x0000FBD8)

Offset: 0x764			Register Name: AC_DRC1_HOPL
Bit	R/W	Default/Hex	Description
15:0	R/W	0xFBD8	The output of the limiter which determine by equation $OPT/6.0206$. The format is 8.24 (-25dB)

3.20.5.167. 0x768 DRC1 Limiter Low Output at Limiter Threshold Register(Default Value: 0x0000FBA7)

Offset: 0x768			Register Name: AC_DRC1_LOPL
Bit	R/W	Default/Hex	Description
15:0	R/W	0xFBA7	The output of the limiter which determine by equation $OPT/6.0206$. The format is 8.24 (-25dB)

3.20.5.168. 0x76C DRC1 Expander Theshold High Setting Register(Default Value: 0x00000BA0)

Offset: 0x76C			Register Name: AC_DRC1_HET
Bit	R/W	Default/Hex	Description
15:0	R/W	0x0BA0	The expander threshold setting, which set by the equation that $ETin = -ET/6.0206$, The format is 8.24. (-70dB)

3.20.5.169. 0x770 DRC1 Expander Theshold Low Setting Register(Default Value: 0x00007291)

Offset: 0x770			Register Name: AC_DRC1_LET
Bit	R/W	Default/Hex	Description
15:0	R/W	0x7291	The expander threshold setting, which set by the equation that $ETin = -ET/6.0206$, The format is 8.24. (-70dB)

3.20.5.170. 0x774 DRC1 Expander Slope High Setting Register(Default Value: 0x00000500)

Offset: 0x774			Register Name: AC_DRC1_HKE
Bit	R/W	Default/Hex	Description

15:14	/	/	/
13:0	R/W	0x0050	The slope of the expander which determine by the equation that $K_e = 1/R$, there, R is the ratio of the expander, which always is interger and the k_e must larger than 50. The format is 8.24. (1:5)

3.20.5.171. 0x778 DRC1 Expander Slope Low Setting Register(Default Value: 0x00000000)

Offset: 0x778			Register Name: AC_DRC1_LKE
Bit	R/W	Default/Hex	Description
15:0	R/W	0x0000	The slope of the expander which determine by the equation that $K_e = 1/R$, there, R is the ratio of the expander, which always is interger and the k_e must larger than 50. The format is 8.24. (1:5)

3.20.5.172. 0x77C DRC1 Expander High Output at Expander Threshold Register(Default Value: 0x0000F45F)

Offset: 0x77C			Register Name: AC_DRC1_HOPE
Bit	R/W	Default/Hex	Description
15:0	R/W	0xF45F	The output of the expander which determine by equation $OPE/6.0206$. The format is 8.24 (-70dB)

3.20.5.173. 0x780 DRC1 Expander Low Output at Expander Threshold Register(Default Value: 0x00008D6E)

Offset: 0x780			Register Name: AC_DRC1_LOPE
Bit	R/W	Default/Hex	Description
15:0	R/W	0x8D6E	The output of the expander which determine by equation $OPE/6.0206$. The format is 8.24 (-70dB)

3.20.5.174. 0x784 DRC1 Linear Slope High Setting Register(Default Value: 0x00000100)

Offset: 0x784			Register Name: AC_DRC1_HKN
Bit	R/W	Default/Hex	Description
15:14	/	/	/
13:0	R/W	0x0100	The slope of the linear which determine by the equation that $K_n = 1/R$, there, R is the ratio of the linear, which always is interger. The format is 8.24. (1:1)

3.20.5.175. 0x788 DRC1 Linear Slope Low Setting Register(Default Value: 0x00000000)

Offset: 0x788			Register Name: AC_DRC1_LKN
Bit	R/W	Default/Hex	Description
15:0	R/W	0x0000	The slope of the linear which determine by the equation that $K_n = 1/R$, there, R is the ratio of the linear, which always is interger. The format is 8.24. (1:1)

3.20.5.176. 0x78C DRC1 Smooth filter Gain High Attack Time Coef Register(Default Value: 0x00000002)

Offset: 0x78C			Register Name: AC_DRC1_SFHAT
Bit	R/W	Default/Hex	Description
15:11	/	/	/
10:0	R/W	0x0002	The smooth filter attack time parameter setting, which determine by the equation that $AT = 1 - \exp(-2.2T_s/tr)$. The format is 3.24. (5ms)

3.20.5.177. 0x790 DRC1 Smooth filter Gain Low Attack Time Coef Register(Default Value: 0x00005600)

Offset: 0x790			Register Name: AC_DRC1_SFLAT
Bit	R/W	Default/Hex	Description
15:0	R/W	0x5600	The smooth filter attack time parameter setting, which determine by the equation that $AT = 1 - \exp(-2.2T_s/tr)$. The format is 3.24. (5ms)

3.20.5.178. 0x794 DRC1 Smooth filter Gain High Release Time Coef Register(Default Value: 0x00000000)

Offset: 0x794			Register Name: AC_DRC1_SFHRT
Bit	R/W	Default/Hex	Description
15:11	/	/	/
10:0	R/W	0x0000	The gain smooth filter release time parameter setting, which determine by the equation that $RT = 1 - \exp(-2.2T_s/tr)$. The format is 3.24. (200ms)

3.20.5.179. 0x798 DRC1 Smooth filter Gain Low Release Time Coef Register(Default Value: 0x00000F04)

Offset: 0x798			Register Name: AC_DRC1_SFHRT
Bit	R/W	Default/Hex	Description
15:0	R/W	0x0F04	The gain smooth filter release time parameter setting, which determine

			by the equation that $RT = 1 - \exp(-2.2T_s/tr)$. The format is 3.24. (200ms)
--	--	--	--

3.20.5.180. 0x79C DRC1 MAX Gain High Setting Register(Default Value: 0x0000FE56)

Offset: 0x79C			Register Name: AC_DRC1_MXGHS
Bit	R/W	Default/Hex	Description
15:0	R/W	0xFE56	The max gain setting which determine by equation MXG/6.0206. The format is 8.24 and must $-20dB < MXG < 30dB$ (-10dB)

3.20.5.181. 0x7A0 DRC1 MAX Gain Low Setting Register(Default Value: 0x0000CB0F)

Offset: 0x7A0			Register Name: AC_DRC1_MXGLS
Bit	R/W	Default/Hex	Description
15:0	R/W	0xCB0F	The max gain setting which determine by equation MXG/6.0206. The format is 8.24 and must $-20dB < MXG < 30dB$ (-10dB)

3.20.5.182. 0x7A4 DRC1 MIN Gain High Setting Register(Default Value: 0x0000F95B)

Offset: 0x7A4			Register Name: AC_DRC1_MNGHS
Bit	R/W	Default/Hex	Description
15:0	R/W	0xF95B	The min gain setting which determine by equation MXG/6.0206. The format is 8.24 and must $-60dB \leq MNG \leq -40dB$ (-40dB)

3.20.5.183. 0x7A8 DRC1 MIN Gain Low Setting Register(Default Value: 0x00002C3F)

Offset: 0x7A8			Register Name: AC_DRC1_MNGLS
Bit	R/W	Default/Hex	Description
15:0	R/W	0x2C3F	The min gain setting which determine by equation MNG/6.0206. The format is 8.24 and must $-60dB \leq MNG \leq -40dB$ (-40dB)

3.20.5.184. 0x7AC DRC1 Expander Smooth Time High Coef Register(Default Value: 0x00000000)

Offset: 0x7AC			Register Name: AC_DRC1_EPSHC
Bit	R/W	Default/Hex	Description
11:0	R/W	0x0000	The gain smooth filter release and attack time parameter setting in expander region, which determine by the equation that $RT = 1 - \exp(-2.2T_s/tr)$. The format is 3.24. (30ms)

3.20.5.185. 0x7B0 DRC1 Expander Smooth Time Low Coef Register(Default Value: 0x0000640C)

Offset: 0x7B0			Register Name: AC_DRC1_EPSLC
Bit	R/W	Default/Hex	Description
15:0	R/W	0x640C	The gain smooth filter release and attack time parameter setting in expander region, which determine by the equation that $RT = 1 - \exp(-2.2Ts/tr)$. The format is 3.24. (30ms)

3.20.5.186. 0x7B8 DRC1 HPF Gain High Coef Register(Default Value: 0x00000100)

Offset: 0x7B8			Register Name: AC_DRC1_HPFHGAIN
Bit	R/W	Default/Hex	Description
15:11	/	/	/
10:0	R/W	0x0100	The gain of the hpf coefficient setting which format is 3.24.(gain = 1)

3.20.5.187. 0x7BC DRC1 HPF Gain Low Coef Register(Default Value: 0x00000000)

Offset: 0x7BC			Register Name: AC_DRC1_HPFLGAIN
Bit	R/W	Default/Hex	Description
15:0	R/W	0x0000	The gain of the hpf coefficient setting which format is 3.24.(gain = 1)

3.20.5.188. AC_PR Configuration Register

The Analog domain register can be write/Read through the AC_PR Configuration Register(AC_PR_CFG_REG) which is in the PRCM Spec. To configure the codec analog domain circuit through this register.

- Reset: Reset signal;
- ADDR[4:0] :AC_PR address;
- W/R :write/read enable;
- WDAT[7:0] :write data;
- RDAT[7:0] : read data.

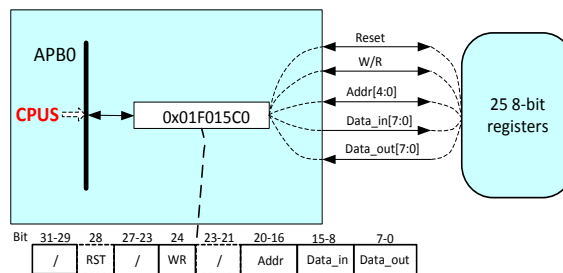

Figure 3-21. AC_PR Configuration Register function

3.20.5.189. 0x00 Headphone Amplifier Control Register(Default Value: 0x00)

Offset: 0x00			Register Name: HP_CTRL
Bit	R/W	Default/Hex	Description
7	R/W	0x0	PA_CLK_GATE PA clock gating control; when system VDD is off and Audio analog channel is working, this bit must be set to 1, because the PA clock come from system VDD domain. When this bit is 1, the Zero cross over function will be disabled automatically. 0: not gating; 1: gating
6	R/W	0x0	HPPA_EN Right & Left Headphone PA Enable 0: Disable; 1: Enable
5:0	R/W	0x0	HPVOL Headphone Volume Control, (HPVOL): Total 64 level, from 0dB to -62dB, 1dB/step, mute when 000000

3.20.5.190. 0x01 Output Left Mixer Control Register(Default Value: 0x00)

Offset: 0x01			Register Name: OL_MIX_CTRL
Bit	R/W	Default/Hex	Description
7	R/W	0x0	/
6:0	R/W	0x0	LMIXMUTE Left Output Mixer Mute Control 0-Mute, 1-Not mute Bit 6: MIC1 Boost stage Bit 5: MIC2 Boost stage Bit 4: xxx Bit 3: xxx Bit 2: LINEINL Bit 1: Left channel DAC Bit 0: Right channel DAC

3.20.5.191. 0x02 Output Right Mixer Control Register(Default Value: 0x00)

Offset: 0x02			Register Name: OR_MIX_CTRL
Bit	R/W	Default/Hex	Description
7	R/W	0x0	/

6:0	R/W	0x00	<p>RMIXMUTE Right Output Mixer Mute Control, (???)rmixs) 0-Mute, 1-Not mute Bit 6: MIC1 Boost stage Bit 5: MIC2 Boost stage Bit 4: xxx Bit 3: xxx Bit 2: LINEINR Bit 1: Right channel DAC Bit 0: Left channel DAC</p>
-----	-----	------	---

3.20.5.192. 0x03 Earpiece Control Register 0 (Default Value: 0x00)

Offset: 0x03			Register Name: EARPIECE_CTRL0
Bit	R/W	Default/Hex	Description
7:6	/	/	/
5:4	R/W	0x0	<p>EAR_RAMP_TIME Earpiece ramp time select 00: 131ms 01: 262ms 10: 395ms 11: 524ms</p>
3:2	/	/	/
1:0	R/W	0x0	<p>ESPSR Earpiece input source select 00: DACR 01: DACL 10: Right Analog Mixer 11: Left Analog Mixer</p>

3.20.5.193. 0x04 Earpiece Control Register 1 (Default Value: 0x00)

Offset: 0x04			Register Name: EARPIECE_CTRL1
Bit	R/W	Default/Hex	Description
7	R/W	0x0	<p>ESPPA_EN Earspeaker PA Enable 0: Disable; 1: Enable</p>
6	R/W	0x0	<p>ESPPA_MUTE All input source to Earspeaker PA mute 0: mute; 1: on</p>
5	R/W	0x0	/

4:0	R/W	0x00	ESP_VOL Earspeaker VOLume control, total 31 level from 0dB to -43.5dB, 1.5dB/step, mute when 00000&00001
-----	-----	------	---

3.20.5.194. 0x05 LINEOUT Control Register 0 (Default Value: 0x00)

Offset: 0x05			Register Name: LINEOUT_CTRL0
Bit	R/W	Default/Hex	Description
7	R/W	0x0	Lineout Left Enable 0: Disable 1: Enable
6	R/W	0x0	Lineout Right Enable 0: Disable 1: Enable
5	R/W	0x0	Left lineout source select 0-left output mixer 1-left output mixer + right output mixer
4	R/W	0x0	Right lineout source select 0-right output mixer 1-left lineout, for differential output
3:0	/	/	/

3.20.5.195. 0x06 LINEOUT Control Register 1 (Default Value: 0x00)

Offset: 0x06			Register Name: LINEOUT_CTRL1
Bit	R/W	Default/Hex	Description
7:5	/	/	/
4:0	R/W	0x00	Lineout Volume Control, Total 31 level, from 0dB to -43.5dB, 1.5dB/step, mute when 00000 & 00001

3.20.5.196. 0x07 MIC1 Control Register (Default Value: 0x34)

Offset: 0x07			Register Name: MIC1_CTRL
Bit	R/W	Default/Hex	Description
7	/	/	/
6:4	R/W	0x3	MIC1G, (volm1) MIC1 BOOST stage to L or R output mixer Gain Control From -4.5dB to 6dB, 1.5dB/step, default is 0dB
3	R/W	0x0	MIC1AMPEN MIC1 Boost AMP Enable

			0-Disable; 1-Enable
2:0	R/W	0x4	MIC1BOOST MIC1 Boost AMP Gain Control 0dB when 000, 24dB to 42dB when 001 to 111, 3dB/step, default is 33dB

3.20.5.197. 0x08 MIC2 Control Register (Default Value: 0x11)

Offset: 0x08			Register Name: MIC2_CTRL
Bit	R/W	Default/Hex	Description
7	R/W	0x1	MIC2 Source select 0: MICIN3 1: MICIN2
6:4	R/W	0x3	MIC2G. MIC2 BOOST stage to L or R output mixer Gain Control From -4.5dB to 6dB, 1.5dB/step, default is 0dB
3	R/W	0x0	MIC2AMPEN MIC2 Boost AMP Enable 0-Disable; 1-Enable
2:0	R/W	0x4	MIC2BOOST MIC2 Boost AMP Gain Control 0dB when 000, 24dB to 42dB when 001 to 111, 3dB/step, default is 33dB

3.20.5.198. 0x09 Linein Control Register (Default Value: 0x03)

Offset: 0x09			Register Name: LINEIN_CTRL
Bit	R/W	Default/Hex	Description
7:3	/	/	/
2:0	R/W	0x3	LINEING. LINEINL/R to L/R output mixer Gain Control From -4.5dB to 6dB, 1.5dB/step, default is 0dB

3.20.5.199. 0x0A Mixer and DAC Control Register (Default Value: 0x00)

Offset: 0x0A			Register Name: MIX_DAC_CTRL
Bit	R/W	Default/Hex	Description
7	R/W	0x0	DACAREN Internal Analog Right channel DAC Enable 0:Disable; 1:Enable
6	R/W	0x0	DACALEN Internal Analog Left channel DAC Enable 0:Disable; 1:Enable

5	R/W	0x0	RMIXEN Right Analog Output Mixer Enable 0:Disable; 1:Enable
4	R/W	0x0	LMIXEN Left Analog Output Mixer Enable 0:Disable; 1:Enable
3	R/W	0x0	RHPPAMUTE All input source to Right Headphone PA mute, including Right Output mixer and Internal Right channel DAC: 0:Mute, 1: Not mute
2	R/W	0x0	LHPPAMUTE All input source to Left Headphone PA mute, including Left Output mixer and Internal Left channel DAC: 0:Mute, 1: Not mute
1	R/W	0x0	RHPIS Right Headphone Power Amplifier (PA) Input Source Select 0: Right channel DAC 1: Right Analog Mixer
0	R/W	0x0	LHPIS Left Headphone Power Amplifier (PA) Input Source Select 0: Left channel DAC 1: Left Analog Mixer

3.20.5.200. 0x0B Left ADC Mixer Control Register (Default Value: 0x00)

Offset: 0x0B			Register Name: L_ADCMIX_SRC
Bit	R/W	Default/Hex	Description
7	R/W	0x0	/
6:0	R/W	0x0	LADCMIXMUTE Left ADC Mixer Mute Control: 0: Mute; 1:On Bit 6: MIC1 Boost stage Bit 5: MIC2 Boost stage Bit 4: xxx Bit 3: xxx Bit 2: LINEINL Bit 1: Left output mixer Bit 0: Right output mixer

3.20.5.201. 0x0C Right ADC Mixer Control Register (Default Value: 0x00)

Offset: 0x0C			Register Name: R_ADCMIX_SRC
Bit	R/W	Default/Hex	Description
7	R/W	0x0	/
6:0	R/W	0x0	RADCMIXMUTE Right ADC Mixer Mute Control: 0: Mute; 1:On Bit 6: MIC1 Boost stage Bit 5: MIC2 Boost stage Bit 4: xxx Bit 3: xxx Bit 2: LINEINR Bit 1: Right output mixer Bit 0: Left output mixer

3.20.5.202. 0x0D ADC Control Register (Default Value: 0x03)

Offset: 0x0D			Register Name: ADC_CTRL
Bit	R/W	Default/Hex	Description
7	R/W	0x0	ADCREN ADC Right Channel Enable 0-Disable; 1-Enable
6	R/W	0x0	ADCLEN ADC Left Channel Enable 0-Disable; 1-Enable
5:3	R/W	0x0	/
2:0	R/W	0x3	ADCG ADC Input Gain Control From -4.5dB to 6dB, 1.5dB/step default is 0dB

3.20.5.203. 0x0E Headset Microphone Bias Control Register (Default Value: 0x21)

Offset: 0x0E			Register Name: HS_MBIAS_CTRL
Bit	R/W	Default/Hex	Description
7	R/W	0x0	MMICBIASEN Master Microphone Bias enable 0: disable, 1: enable
6:5	R/W	0x1	MBIASSEL MMICBIAS voltage level select 00: 1.88V

			01: 2.09V 10: 2.33V 11: 2.50V
1:0	R/W	0x1	HBIASSEL HMICBIAS voltage level select 00: 1.88V 01: 2.09V 10: 2.33V 11: 2.50V

3.20.5.204. 0x0F Analog Performance Tuning Register (Default Value: 0xD6)

Offset: 0x0F			Register Name: APT_REG
Bit	R/W	Default/Hex	Description
7	R/W	0x1	MMIC BIAS chopper enable 0: disable; 1:enable
6:5	R/W	0x10	MMIC BIAS chopper clock select 00: 250KHz; 01: 500KHz; 10: 1MHz; 11: 2MHz
4	R/W	0x1	DITHER ADC dither on/off control 0: dither off; 1: dither on
3:2	R/W	0x1	DITHER_CLK_SELECT ADC dither clock select 00: ADC FS * (8/9), about 43KHz when FS=48KHz 01: ADC FS * (16/15), about 51KHz when FS=48KHz 10: ADC FS * (4/3), about 64KHz when FS=48KHz 11: ADC FS * (16/9), about 85KHz when FS=48KHz
1:0	R/W	0x10	BIHE_CTRL, BIHE control 00: no BIHE 01: BIHE=7.5 HOSC 10: BIHE=11.5 HOSC 11: BIHE=15.5 HOSC

3.20.5.205. 0x10 OP BIAS Control Register0 (Default Value: 0x55)

Offset: 0x10			Register Name: OP_BIAS_CTRL0
Bit	R/W	Default/Hex	Description
7:6	R/W	0x01	OPDRV_OPEAR_CUR. OPDRV/OPEAR output stage current setting
5:4	R/W	0x01	OPADC1_BIAS_CUR.

			OPADC1 Bias Current Select
3:2	R/W	0x01	OPADC2_BIAS_CUR. OPADC2 Bias Current Select
1:0	R/W	0x01	OPAAF_BIAS_CUR. OPAAF in ADC Bias Current Select

3.20.5.206. 0x11 OP BIAS Control Register1 (Default Value: 0x55)

Offset: 0x11			Register Name: OP_BIAS_CTRL1
Bit	R/W	Default/Hex	Description
7:6	R/W	0x01	OPMIC_BIAS_CUR OPMIC Bias Current Control
5:4	R/W	0x01	OPVR_BIAS_CUR. OPVR Bias Current Control
3:2	R/W	0x01	OPDAC_BIAS_CUR. OPDAC Bias Current Control
1:0	R/W	0x01	OPMIX_BIAS_CUR. OPMIX/OPLPF/OPDRV/OPEAR Bias Current Control

3.20.5.207. 0x12 USB Bias & Volume Change Control Register (Default Value: 0x02)

Offset: 0x12			Register Name: ZC_VOL_CTRL
Bit	R/W	Default/Hex	Description
7:6	R/W	0x0	function enable for master volume change at zero cross over 0: disable; 1: enable
5:4	R/W	0x0	Timeout control for master volume change at zero cross over 0: 32ms; 1: 64ms
3	/	/	/
2:0	R/W	0x2	USB_BIAS_CUR. USB bias current tuning From 23uA to 30uA, Default is 25uA

3.20.5.208. 0x13 Bias Calibration Data Register (Default Value: 0x00)

Offset: 0x13			Register Name: BIAS_CAL_DATA
Bit	R/W	Default/Hex	Description
7:6	/	/	/
5:0	R	/	BIASCALI Bias Calibration Data, 6bit

3.20.5.209. 0x14 Bias Calibration Set Data Register (Default Value: 0x20)

Offset: 0x14			Register Name: BIAS_CAL_SET
Bit	R/W	Default/Hex	Description
7:6	R/W	00	SELETDACDY Select the delay time to pull low the micdet when jack removal 00: 0.5ms 01: 1ms 10: 1.5ms 11: 2ms
5:0	R/W	0x20	BIASVERIFY Bias Register Setting Data

3.20.5.210. 0x15 Bias & DA16 Calibration Control Register (Default Value: 0x00)

Offset: 0x15			Register Name: BD_CAL_CTRL
Bit	R/W	Default/Hex	Description
7	R/W	0x0	PA_SPEED_SELECT PA setup speed control (for testing) 0: slow; 1: fast
6	R/W	0x0	CURRENT_TEST_SELECT Internal current sink test enable (from LINEIN pin) 0:Normal; 1: For Debug
5:3	/	/	/
2	R/W	0x0	BIAS calibration mode select 0: average; 1: single
1	R/W	0x0	BIAS and HP calibration control Write 1 to this bit, the calibration will be doing again. Then this bit will be reset to zero automatically
0	R/W	0x0	BIASCALVERIFY Bias Calibration Verify 0: Calibration; 1: Register setting

3.20.5.211. 0x16 Headphone PA Control Register (Default Value: 0xF1)

Offset: 0x16			Register Name: HP_PA_CTRL
Bit	R/W	Default/Hex	Description
7	R/W	0x1	BUFFERENABLE When this bit is write to 0, the buffer in headphone disabled
6	R/W	0x1	HPMUTENABLE When this bit is write to 0, all input to headphone is mute

5	R/W	0x1	HPINPUTENABLE When this bit is write to 0, the input stage of headphone disabled
4	R/W	0x1	HPOUTPUTENABLE When this bit is write to 0, the output stage of headphone disabled
3:2	R/W	0x0	HPPA_DEL Headphone delay time when start up 00: 4ms 01: 8ms 10: 16ms 11: 32ms
1:0	R/W	0x1	CP_CLKS Charge Pump Clock select 00: 250k 01: 330k 10: 400k 11: 500k

3.20.5.212. 0x17 Headphone Calibration Control Register (Default Value: 0x04)

Offset: 0x17			Register Name: HP_CAL_CTRL
Bit	R/W	Default/Hex	Description
7	R/W	0	HPCALIFIRST When this bit is write to 1 , HEADPHONE Calibration once before enable
6	R/W	0	/
5	R/W	0	HPCALIMODE HEADPHONE calibration equilibration MODE select 0: equilibration mode 1: no equilibration
4	R/W	0	HPCALIVERIFY HEADPHONE calibration in verify mode enable 0: Disable; 1: Enable
3	R/W	0	/
2:0	R/W	100	HPCALICKS HEADPHONE Calibration clock frequency select 000: 1k ... 100: 16k ... 111: 128k

3.20.5.213. 0x18 Right Headphone Calibration DAT Register (Default Value: 0x00)

Offset: 0x18			Register Name: RHP_CAL_DAT
Bit	R/W	Default/Hex	Description
7:0	R	/	HPRCALI Right Headphone calibration Data

3.20.5.214. 0x19 Right Headphone Calibration Setting Register (Default Value: 0x80)

Offset: 0x19			Register Name: RHP_CAL_SET
Bit	R/W	Default/Hex	Description
7:0	R/W	0x80	HPRCALVERIFY Right Headphone calibration Setting Data

3.20.5.215. 0x1A Left Headphone Calibration DAT Register (Default Value: 0x00)

Offset: 0x1A			Register Name: LHP_CAL_DAT
Bit	R/W	Default/Hex	Description
7:0	R	/	HPLCALI Left Headphone calibration Data

3.20.5.216. 0x1B Left Headphone Calibration Setting Register (Default Value: 0x80)

Offset: 0x1B			Register Name: LHP_CAL_SET
Bit	R/W	Default/Hex	Description
7:0	R/W	0x80	HPLCALVERIFY Left Headphone calibration Setting Data

3.20.5.217. 0x1C Mic detect Control Register (Default Value: 0x40)

Offset: 0x1C			Register Name: MDET_CTRL
Bit	R/W	Default/Hex	Description
7	R/W	0	/
6:4	R/W	100	SELDETADCFS Select sample interval of the ADC sample 000: 2ms ... 100: 32ms

			... 111: 256ms
3:2	R/W	00	SELDETADCDB Select debounce time when jack removal 00: 128ms 01: 256ms 10: 512ms 11: 1024ms
1:0	R/W	00	SELDETADCBF Select the time to enable HBIAS before micadc work 00: 2ms 01: 4ms 10: 8ms 11: 16ms

3.20.5.218. 0x1D Jack & Mic detect Control Register (Default Value: 0x00)

Offset: 0x1D			Register Name: JACK_MIC_CTRL
Bit	R/W	Default/Hex	Description
7	R/W	0	JACKDETEN Jack detect enable 0: disable, 1: enable
6	R/W	0	INNERRESEN Inner 2.2k resistor between hbias and micdet enable 0: disable, 1: enable
5	R/W	0	HMICBIASEN Handset Microphone Bias enable 0: disable, 1: enable
4	R/W	0	MICADCEN Microphone detect ADC enable 0: disable, 1: enable
3	R/W	0	POPFREE When this bit is 0, HBIAS MICADC is controlled by register
2	R/W	0	/
1	R/W	0	AUTOPLEN Enable the function to auto pull low micdet when jack removal 0: disable, 1: enable
0	R/W	0	MICDETPL When this bit is 1 and AUTOPLEN is 0, the micdet is pull to gnd

3.20.5.219. 0x1E Phone Output Register (Default Value: 0x60)

Offset: 0x1E			Register Name: PHOUT_CTRL
Bit	R/W	Default/Hex	Description
7:5	R/W	011	PHONEOUTG Phone-out Gain Control From -4.5dB to 6dB, 1.5dB/step, default is 0dB
4	R/W	0	PHONEOUT enable 0: Disable 1: Enable
3	R/W	0	PHONEOUTS3 MIC1 Boost stage to Phone out mute 0: Mute, 1: Not mute
2	R/W	0	PHONEOUTS2 MIC2 Boost stage to Phone out mute 0: Mute, 1: Not mute
1	R/W	0	PHONEOUTS1 Right Output mixer to Phone out mute 0: Mute, 1: Not mute
0	R/W	0	PHONEOUTS0 Left Output mixer to Phone out mute 0: Mute, 1: Not mute

3.20.5.220. 0x1F Phone Input Register (Default Value: 0x34)

Offset: 0x1F			Register Name: PHIN_CTRL
Bit	R/W	Default/Hex	Description
7	R/W	0	/
6:4	R/W	011	PHONEG, (volpn) PHONEP/N/G to Right output mixer Gain Control From -4.5dB to 6dB, 1.5dB/step, default is 0dB
4	R/W	0	/
2:0	R/W	100	PHONEPREG PHONEP-PHONEN pre-amplifier gain control -12dB to 9dB, 3dB/step, default is 0dB

3.21. Port Controller(CPUx-PORT)

The chip has 7 ports for multi-functional input/out pins. They are shown below:

- Port B(PB): 10 input/output port
- Port C(PC): 17 input/output port
- Port D(PD): 25 input/output port
- Port E(PE): 18 input/output port
- Port F(PF): 7 input/output port
- Port G(PG): 14 input/output port
- Port H(PH): 12 input/output port

For various system configurations, these ports can be easily configured by software. All these ports can be configured as GPIO if multiplexed functions are not used. The total 3 group external PIO interrupt sources are supported and interrupt mode can be configured by software.

3.21.1. Port Controller Register List

Module Name	Base Address
PIO	0x01C20800

Register Name	Offset	Description
Pn_CFG0	n*0x24+0x00	Port n Configure Register 0 (n from 1 to 7)
Pn_CFG1	n*0x24+0x04	Port n Configure Register 1 (n from 1 to 7)
Pn_CFG2	n*0x24+0x08	Port n Configure Register 2 (n from 1 to 7)
Pn_CFG3	n*0x24+0x0C	Port n Configure Register 3 (n from 1 to 7)
Pn_DAT	n*0x24+0x10	Port n Data Register (n from 1 to 7)
Pn_DRV0	n*0x24+0x14	Port n Multi-Driving Register 0 (n from 1 to 7)
Pn_DRV1	n*0x24+0x18	Port n Multi-Driving Register 1 (n from 1 to 7)
Pn_PUL0	n*0x24+0x1C	Port n Pull Register 0 (n from 1 to 7)
Pn_PUL1	n*0x24+0x20	Port n Pull Register 1 (n from 1 to 7)
Pn_INT_CFG0	0x200+0*0x20+0x00	PIO Interrupt Configure Register 0
Pn_INT_CFG1	0x200+0*0x20+0x04	PIO Interrupt Configure Register 1
Pn_INT_CFG2	0x200+0*0x20+0x08	PIO Interrupt Configure Register 2
Pn_INT_CFG3	0x200+0*0x20+0x0C	PIO Interrupt Configure Register 3
Pn_INT_CTL	0x200+0*0x20+0x10	PIO Interrupt Control Register
Pn_INT_STA	0x200+0*0x20+0x14	PIO Interrupt Status Register
Pn_INT_DEB	0x200+0*0x20+0x18	PIO Interrupt Debounce Register

3.21.2. Port Controller Register Description

3.21.2.1. PB Configure Register 0 (Default Value: 0x77777777)

Offset: 0x24			Register Name: PB_CFG0_REG
Bit	R/W	Default/Hex	Description
31	/	/	/
30:28	R/W	0x7	PB7_SELECT 000: Input 001: Output 010: AIF2_DIN 011: PCM0_DIN 100: Reserved 101: SIM_DET 110: PB_EINT7 111: IO Disable
27	/	/	/
26:24	R/W	0x7	PB6_SELECT 000: Input 001: Output 010: AIF2_DOUT 011: PCM0_DOUT 100: Reserved 101: SIM_RST 110: PB_EINT6 111: IO Disable
23	/	/	/
22:20	R/W	0x7	PB5_SELECT 000: Input 001: Output 010: AIF2_BCLK 011: PCM0_BCLK 100: Reserved 101: SIM_DATA 110: PB_EINT5 111: IO Disable
19	/	/	/
18:16	R/W	0x7	PB4_SELECT 000: Input 001: Output 010: AIF2_SYNC 011: PCM0_SYNC 100: Reserved 101: SIM_CLK 110: PB_EINT4 111: IO Disable
15	/	/	/
14:12	R/W	0x7	PB3_SELECT 000: Input 001: Output 010: UART2_CTS 011: I2S0_MCLK 100: JTAG_DIO 101: SIM_VPPPP 110: PB_EINT3 111: IO Disable
11	/	/	/
10:8	R/W	0x7	PB2_SELECT 000: Input 001: Output 010: UART2_RTS 011: Reserved 100: JTAG_DOO 101: SIM_VPPEN 110: PB_EINT2 111: IO Disable
7	/	/	/

6:4	R/W	0x7	PB1_SELECT 000: Input 010: UART2_RX 100: JTAG_CK0 110: PB_EINT1	001: Output 011: Reserved 101: SIM_PWREN 111: IO Disable
3	/	/	/	
2:0	R/W	0x7	PBO_SELECT 000: Input 010: UART2_TX 100: JTAG_MS0 110: PB_EINT0	001: Output 011: Reserved 101: Reserved 111: IO Disable

3.21.2.2. PB Configure Register 1 (Default Value: 0x0000077)

Offset: 0x28			Register Name: PB_CFG1_REG	
Bit	R/W	Default/Hex	Description	
31:7	/	/	/	
6:4	R/W	0x7	PB9_SELECT 000: Input 010: Reserved 100: UART0_RX 110: PB_EINT9	001: Output 011: Reserved 101: Reserved 111: IO Disable
3	/	/	/	
2:0	R/W	0x7	PB8_SELECT 000: Input 010: Reserved 100: UART0_TX 110: PB_EINT8	001: Output 011: Reserved 101: Reserved 111: IO Disable

3.21.2.3. PB Configure Register 2 (Default Value: 0x0000000)

Offset: 0x2C			Register Name: PB_CFG2_REG
Bit	R/W	Default/Hex	Description
31:0	/	/	/

3.21.2.4. PB Configure Register 3 (Default Value: 0x0000000)

Offset: 0x30			Register Name: PB_CFG3_REG
Bit	R/W	Default/Hex	Description
31:0	/	/	/

3.21.2.5. PB Data Register (Default Value: 0x00000000)

Offset: 0x34			Register Name: PB_DATA_REG
Bit	R/W	Default/Hex	Description
31:10	/	/	/
9:0	R/W	0x0	<p>PB_DAT</p> <p>If the port is configured as input, the corresponding bit is the pin state. If the port is configured as output, the pin state is the same as the corresponding bit. The read bit value is the value setup by software. If the port is configured as functional pin, the undefined value will be read.</p>

3.21.2.6. PB Multi-Driving Register 0 (Default Value: 0x00055555)

Offset: 0x38			Register Name: PB_DRV0_REG
Bit	R/W	Default/Hex	Description
31:20	/	/	/
$[2i+1:2i]$ $(i=0\sim9)$	R/W	0x1	<p>PB_DRV</p> <p>PB[n] Multi-Driving Select (n = 0~9)</p> <p>00: Level 0 01: Level 1</p> <p>10: Level 2 11: Level 3</p>

3.21.2.7. PB Multi-Driving Register 1 (Default Value: 0x00000000)

Offset: 0x3C			Register Name: PB_DRV1_REG
Bit	R/W	Default/Hex	Description
31:0	/	/	/

3.21.2.8. PB PULL Register 0 (Default Value: 0x00000000)

Offset: 0x40			Register Name: PB_PULL0_REG
Bit	R/W	Default/Hex	Description
31:20	/	/	Reserved
$[2i+1:2i]$ $(i=0\sim9)$	R/W	0x0	<p>PB_PULL</p> <p>PB[n] Pull-up/down Select (n = 0~9)</p> <p>00: Pull-up/down disable 01: Pull-up</p> <p>10: Pull-down 11: Reserved</p>

3.21.2.9. PB PULL Register 1 (Default Value: 0x00000000)

Offset: 0x44			Register Name: PB_PULL1_REG
Bit	R/W	Default/Hex	Description
31:0	/	/	/

3.21.2.10. PC Configure Register 0 (Default Value: 0x77777777)

Offset: 0x48			Register Name: PC_CFG0_REG
Bit	R/W	Default/Hex	Description
31	/	/	/
30:28	R/W	0x7	PC7_SELECT 000: Input 001: Output 010: NAND_RB1 011: Reserved 100: Reserved 101: Reserved 110: Reserved 111: IO Disable
27	/	/	/
26:24	R/W	0x7	PC6_SELECT 000: Input 001: Output 010: NAND_RB0 011: SDC2_CMD 100: Reserved 101: Reserved 110: Reserved 111: IO Disable
23	/	/	/
22:20	R/W	0x7	PC5_SELECT 000: Input 001: Output 010: NAND_RE 011: SDC2_CLK 100: Reserved 101: Reserved 110: Reserved 111: IO Disable
19	/	/	/
18:16	R/W	0x7	PC4_SELECT 000: Input 001: Output 010: NAND_CE0 011: Reserved 100: Reserved 101: Reserved 110: Reserved 111: IO Disable
15	/	/	/
14:12	R/W	0x7	PC3_SELECT 000: Input 001: Output 010: NAND_CE1 011: Reserved 100: SPIO_CS 101: Reserved 110: Reserved 111: IO Disable
11	/	/	/
10:8	R/W	0x7	PC2_SELECT

			000: Input 010: NAND_CLE 100: SPI0_CLK 110: Reserved	001: Output 011: Reserved 101: Reserved 111: IO Disable
7	/	/	/	
6:4	R/W	0x7	PC1_SELECT 000: Input 010: NAND_ALE 100: SPI0_MISO 110: Reserved	001: Output 011: SDC2_DS 101: Reserved 111: IO Disable
3	/	/	/	
2:0	R/W	0x7	PC0_SELECT 000: Input 010: NAND_WE 100: SPI0_MOSI 110: Reserved	001: Output 011: Reserved 101: Reserved 111: IO Disable

3.21.2.11. PC Configure Register 1 (Default Value: 0x77777777)

Offset: 0x4C			Register Name: PC_CFG1_REG	
Bit	R/W	Default/Hex	Description	
31	/	/	/	
30:28	R/W	0x7	PC15_SELECT 000:Input 010:NAND_DQ7 100:Reserved 110:Reserved	001:Output 011:SDC2_D7 101:Reserved 111:IO Disable
27	/	/	/	
26:24	R/W	0x7	PC14_SELECT 000:Input 010:NAND_DQ6 100:Reserved 110:Reserved	001:Output 011:SDC2_D6 101:Reserved 111:IO Disable
23	/	/	/	
22:20	R/W	0x7	PC13_SELECT 000:Input 010:NAND_DQ5 100:Reserved 110:Reserved	001:Output 011:SDC2_D5 101:Reserved 111:IO Disable
19	/	/	/	
18:16	R/W	0x7	PC12_SELECT 000:Input	001:Output

			010:NAND_DQ4 100:Reserved 110:Reserved	011:SDC2_D4 101:Reserved 111:IO Disable
15	/	/	/	
14:12	R/W	0x7	PC11_SELECT 000:Input 010:NAND_DQ3 100:Reserved 110:Reserved	001:Output 011:SDC2_D3 101:Reserved 111:IO Disable
11	/	/	/	
10:8	R/W	0x7	PC10_SELECT 000:Input 010:NAND_DQ2 100:Reserved 110:Reserved	001:Output 011:SDC2_D2 101:Reserved 111:IO Disable
7	/	/	/	
6:4	R/W	0x7	PC9_SELECT 000:Input 010:NAND_DQ1 100:Reserved 110:Reserved	001:Output 011:SDC2_D1 101:Reserved 111:IO Disable
3	/	/	/	
2:0	R/W	0x7	PC8_SELECT 000:Input 010:NAND_DQ0 100:Reserved 110:Reserved	001:Output 011:SDC2_D0 101:Reserved 111:IO Disable

3.21.2.12. PC Configure Register 2 (Default Value: 0x00000777)

Offset: 0x50			Register Name: PC_CFG2_REG
Bit	R/W	Default/Hex	Description
31:11	/	/	/
10:8	R/W	0x7	/
7	/	/	/
6:4	R/W	0x7	/
3	/	/	/
2:0	R/W	0x7	PC16_SELECT 000:Input 010:NAND_DQS 100:Reserved 110:Reserved
			001:Output 011:SDC2_RST 101:Reserved 111:IO Disable

3.21.2.13. PC Configure Register 3 (Default Value: 0x00000000)

Offset: 0x54			Register Name: PC_CFG3_REG
Bit	R/W	Default/Hex	Description
31:0	/	/	/

3.21.2.14. PC Data Register (Default Value: 0x00000000)

Offset: 0x58			Register Name: PC_DATA_REG
Bit	R/W	Default/Hex	Description
31:19	/	/	/
18:0	R/W	0x0	PC_DAT If the port is configured as input, the corresponding bit is the pin state. If the port is configured as output, the pin state is the same as the corresponding bit. The read bit value is the value setup by software. If the port is configured as functional pin, the undefined value will be read.

3.21.2.15. PC Multi-Driving Register 0 (Default Value: 0x55555555)

Offset: 0x5C			Register Name: PC_DRV0_REG
Bit	R/W	Default/Hex	Description
[2i+1:2i] (i=0~15)	R/W	0x1	PC_DRV PC[n] Multi-Driving SELECT (n = 0~15) 00: Level 0 01: Level 1 10: Level 2 11: Level 3

3.21.2.16. PC Multi-Driving Register 1 (Default Value: 0x00000015)

Offset: 0x60			Register Name: PC_DRV1_REG
Bit	R/W	Default/Hex	Description
31:6	/	/	/
[2i+1:2i] (i=0~2)	R/W	0x1	PC_DRV PC[n] Multi-Driving Select (n = 16~18) 00: Level 0 01: Level 1 10: Level 2 11: Level 3

3.21.2.17. PC PULL Register 0 (Default Value: 0x00005140)

Offset: 0x64			Register Name: PC_PULL0_REG
Bit	R/W	Default/Hex	Description
[2i+1:2i] (i=0~15)	R/W	0x5140	PC_PULL PC[n] Pull-up/down Select (n = 0~15) 00: Pull-up/down disable 01: Pull-up 10: Pull-down 11: Reserved

3.21.2.18. PC PULL Register 1 (Default Value: 0x00000014)

Offset: 0x68			Register Name: PC_PULL1_REG
Bit	R/W	Default/Hex	Description
31:6	/	/	Reserved
[2i+1:2i] (i=0~2)	R/W	0x14	PC_PULL PC[n] Pull-up/down Select (n = 16~18) 00: Pull-up/down disable 01: Pull-up 10: Pull-down 11: Reserved

3.21.2.19. PD Configure Register 0 (Default Value: 0x77777777)

Offset: 0x6C			Register Name: PD_CFG0_REG
Bit	R/W	Default/Hex	Description
31	/	/	/
30:28	R/W	0x7	PD7_SELECT 000: Input 001: Output 010: LCD_D11 011: Reserved 100: Reserved 101: CCIR_D3 110: Reserved 111: IO Disable
27	/	/	Reserved
26:24	R/W	0x7	PD6_SELECT 000: Input 001: Output 010: LCD_D10 011: Reserved 100: Reserved 101: CCIR_D2 110: Reserved 111: IO Disable
23	/	/	/
22:20	R/W	0x7	PD5_SELECT 000: Input 001: Output 010: LCD_D7 011: UART4_CTS 100: Reserved 101: CCIR_D1 110: Reserved 111: IO Disable

19	/	/	/
18:16	R/W	0x7	PD4_SELECT 000: Input 001: Output 010: LCD_D6 011: UART4_RTS 100: Reserved 101: CCIR_D0 110: Reserved 111: IO Disable
15	/	/	/
14:12	R/W	0x7	PD3_SELECT 000: Input 001: Output 010: LCD_D5 011: UART4_RX 100: SPI1_MISO 101: CCIR_VSYNC 110: Reserved 111: IO Disable
11	/	/	/
10:8	R/W	0x7	PD2_SELECT 000: Input 001: Output 010: LCD_D4 011: UART4_TX 100: SPI1_MOSI 101: CCIR_HSYNC 110: Reserved 111: IO Disable
7	/	/	/
6:4	R/W	0x7	PD1_SELECT 000: Input 001: Output 010: LCD_D3 011: UART3_RX 100: SPI1_CLK 101: CCIR_DE 110: Reserved 111: IO Disable
3	/	/	/
2:0	R/W	0x7	PD0_SELECT 000: Input 001: Output 010: LCD_D2 011: UART3_TX 100: SPI1_CS 101: CCIR_CLK 110: Reserved 111: IO Disable

3.21.2.20. PD Configure Register 1 (Default Value: 0x77777777)

Offset: 0x70			Register Name: PD_CFG1_REG
Bit	R/W	Default/Hex	Description
31	/	/	/
30:28	R/W	0x7	PD15_SELECT 000: Input 001: Output 010: LCD_D21 011: LVDS_VN1 100: RGMII_TXD3/MII_TXD3/RMII_NULL 101: CCIR_D6 110: Reserved 111: IO Disable
27	/	/	/

26:24	R/W	0x7	PD14_SELECT 000: Input 010: LCD_D20 100: RGMII_NULL/MII_RXERR/RMII_RXER 110: Reserved 001: Output 011: LVDS_VP1 101: Reserved 111: IO Disable
23	/	/	/
22:20	R/W	0x7	PD13_SELECT 000: Input 010: LCD_D19 100: RGMII_RXCTL/MII_RXDV/RMII_CRS_DV 110: Reserved 001: Output 011: LVDS_VN0 101: Reserved 111: IO Disable
19	/	/	/
18:16	R/W	0x7	PD12_SELECT 000: Input 010: LCD_D18 100: RGMII_RXCK/MII_RXCK/RMII_NULL 110: Reserved 001: Output 011: LVDS_VP0 101: Reserved 111: IO Disable
15	/	/	/
14:12	R/W	0x7	PD11_SELECT 000: Input 010: LCD_D15 100: RGMII_RXD0/MII_RXD0/RMII_RXD0 110: Reserved 001: Output 011: Reserved 101: Reserved 111: IO Disable
11	/	/	/
10:8	R/W	0x7	PD10_SELECT 000: Input 010: LCD_D14 100: RGMII_RXD1/MII_RXD1/RMII_RXD1 110: Reserved 001: Output 011: Reserved 101: Reserved 111: IO Disable
7	/	/	/
6:4	R/W	0x7	PD9_SELECT 000: Input 010: LCD_D13 100: RGMII_RXD2/MII_RXD2/RMII_NULL 110: Reserved 001: Output 011: Reserved 101: CCIR_D5 111: IO Disable
3	/	/	/
2:0	R/W	0x7	PD8_SELECT 000: Input 010: LCD_D12 100: RGMII_RXD3/MII_RXD3/RMII_NULL 110: Reserved 001: Output 011: Reserved 101: CCIR_D4 111: IO Disable

3.21.2.21. PD Configure Register 2 (Default Value: 0x77777777)

Offset: 0x74			Register Name: PD_CFG2_REG
Bit	R/W	Default/Hex	Description
31	/	/	/
30:28	R/W	0x7	PD23_SELECT 000: Input 001: Output 010: Reserved 011: Reserved 100: MDIO 101: Reserved 110: Reserved 111: IO Disable
27	/	/	/
26:24	R/W	0x7	PD22_SELECT 000: Input 001: Output 010: PWM0 011: Reserved 100: MDC 101: Reserved 110: Reserved 111: IO Disable
23	/	/	/
22:20	R/W	0x7	PD21_SELECT 000: Input 001: Output 010: LCD_VSYNC 011: LVDS_VN3 100: RGMII_CLKIN/MII_COL/RMII_NULL 101: Reserved 110: Reserved 111: IO Disable
19	/	/	/
18:16	R/W	0x7	PD20_SELECT 000: Input 001: Output 010: LCD_HSYNC 011: LVDS_VP3 100: RGMII_TXCTL/MII_TXEN/RMII_TXEN 101: Reserved 110: Reserved 111: IO Disable
15	/	/	/
14:12	R/W	0x7	PD19_SELECT 000: Input 001: Output 010: LCD_DE 011: LVDS_VNC 100: RGMII_TXCK/MII_TXCK/RMII_TXCK 101: Reserved 110: Reserved 111: IO Disable
11	/	/	/
10:8	R/W	0x7	PD18_SELECT 000: Input 001: Output 010: LCD_CLK 011: LVDS_VPC 100: RGMII_TXD0/MII_TXD0/RMII_TXD0 101: Reserved 110: Reserved 111: IO Disable
7	/	/	/
6:4	R/W	0x7	PD17_SELECT 000: Input 001: Output

			010: LCD_D23 100: RGMII_TXD1/MII_TXD1/RMII_TXD1 110: Reserved	011: LVDS_VN2 101: Reserved 111: IO Disable
3	/	/	/	
2:0	R/W	0x7	PD16_SELECT 000: Input 010: LCD_D22 100: RGMII_TXD2/MII_TXD2/RMII_NULL 110: Reserved	001: Output 011: LVDS_VP2 101: CCIR_D7 111: IO Disable

3.21.2.22. PD Configure Register 3 (Default Value: 0x00000007)

Offset: 0x78			Register Name: PD_CFG3_REG	
Bit	R/W	Default/Hex	Description	
31:3	/	/	/	
2:0	R/W	0x7	PD24_SELECT 000: Input 010: Reserved 100: Reserved 110: Reserved	001: Output 011: Reserved 101: Reserved 111: IO Disable

3.21.2.23. PD Data Register (Default Value: 0x00000000)

Offset: 0x7C			Register Name: PD_DATA_REG
Bit	R/W	Default/Hex	Description
31:25	/	/	/
24:0	R/W	0	PD_DAT If the port is configured as input, the corresponding bit is the pin state. If the port is configured as output, the pin state is the same as the corresponding bit. The read bit value is the value setup by software. If the port is configured as functional pin, the undefined value will be read.

3.21.2.24. PD Multi-Driving Register 0 (Default Value: 0x55555555)

Offset: 0x80			Register Name: PD_DRV0_REG
Bit	R/W	Default/Hex	Description
[2i+1:2i] (i=0~15)	R/W	0x1	PD_DRV PD[n] Multi-Driving SELECT (n = 0~15) 00: Level 0 01: Level 1 10: Level 2 11: Level 3

3.21.2.25. PD Multi-Driving Register 1 (Default Value: 0x00015555)

Offset: 0x84			Register Name: PD_DRV1_REG
Bit	R/W	Default/Hex	Description
31:18	/	/	/
[2i+1:2i] (i=0~8)	R/W	0x1	PD_DRV PD[n] Multi-Driving Select (n = 16~24) 00: Level 0 01: Level 1 10: Level 2 11: Level 3

3.21.2.26. PD PULL Register 0 (Default Value: 0x00000000)

Offset: 0x88			Register Name: PD_PULL0_REG
Bit	R/W	Default/Hex	Description
[2i+1:2i] (i=0~15)	R/W	0x0	PD_PULL PD[n] Pull-up/down Select (n = 0~15) 00: Pull-up/down disable 01: Pull-up 10: Pull-down 11: Reserved

3.21.2.27. PD PULL Register 1 (Default Value: 0x00000000)

Offset: 0x8C			Register Name: PD_PULL1_REG
Bit	R/W	Default/Hex	Description
31:18	/	/	Reserved
[2i+1:2i] (i=0~8)	R/W	0x0	PD_PULL PD[n] Pull-up/down Select (n = 16~24) 00: Pull-up/down disable 01: Pull-up 10: Pull-down 11: Reserved

3.21.2.28. PE Configure Register 0 (Default Value: 0x77777777)

Offset: 0x90			Register Name: PE_CFG0_REG
Bit	R/W	Default/Hex	Description
31	/	/	/
30:28	R/W	0x7	PE7_SELECT 000: Input 001: Output 010: CSI_D3 011: Reserved

			100: TS_D3 110: Reserved	101: Reserved 111: IO Disable
27	/	/	/	
26:24	R/W	0x7	PE6_SELECT 000: Input 010: CSI_D2 100: TS_D2 110: Reserved	001: Output 011: Reserved 101: Reserved 111: IO Disable
23	/	/	/	
22:20	R/W	0x7	PE5_SELECT 000: Input 010: CSI_D1 100: TS_D1 110: Reserved	001: Output 011: Reserved 101: Reserved 111: IO Disable
19	/	/	/	
18:16	R/W	0x7	PE4_SELECT 000: Input 010: CSI_D0 100: TS_D0 110: Reserved	001: Output 011: Reserved 101: Reserved 111: IO Disable
15	/	/	/	
14:12	R/W	0x7	PE3_SELECT 000: Input 010: CSI_VSYNC 100: TS_DVLD 110: Reserved	001: Output 011: Reserved 101: Reserved 111: IO Disable
11	/	/	/	
10:8	R/W	0x7	PE2_SELECT 000: Input 010: CSI_HSYNC 100: TS_SYNC 110: Reserved	001: Output 011: Reserved 101: Reserved 111: IO Disable
7	/	/	/	
6:4	R/W	0x7	PE1_SELECT 000: Input 010: CSI_MCLK 100: TS_ERR 110: Reserved	001: Output 011: Reserved 101: Reserved 111: IO Disable
3	/	/	/	
2:0	R/W	0x7	PE0_SELECT 000: Input 010: CSI_PCLK 100: TS_CLK 110: Reserved	001: Output 011: Reserved 101: Reserved 111: IO Disable

3.21.2.29. PE Configure Register 1 (Default Value: 0x77777777)

Offset: 0x94			Register Name: PE_CFG1_REG
Bit	R/W	Default/Hex	Description
31	/	/	/
30:28	R/W	0x7	PE15_SELECT 000: Input 001: Output 010: Reserved 011: TWI2_SDA 100: Reserved 101: Reserved 110: Reserved 111: IO Disable
27	/	/	/
26:24	R/W	0x7	PE14_SELECT 000: Input 001: Output 010: PLL_LOCK_DBG 011: TWI2_SCK 100: Reserved 101: Reserved 110: Reserved 111: IO Disable
23	/	/	/
22:20	R/W	0x7	PE13_SELECT 000: Input 001: Output 010: CSI_SDA 011: Reserved 100: Reserved 101: Reserved 110: Reserved 111: IO Disable
19	/	/	/
18:16	R/W	0x7	PE12_SELECT 000: Input 001: Output 010: CSI_SCK 011: Reserved 100: Reserved 101: Reserved 110: Reserved 111: IO Disable
15	/	/	/
14:12	R/W	0x7	PE11_SELECT 000: Input 001: Output 010: CSI_D7 011: Reserved 100: TS_D7 101: Reserved 110: Reserved 111: IO Disable
11	/	/	/
10:8	R/W	0x7	PE10_SELECT 000: Input 001: Output 010: CSI_D6 011: Reserved 100: TS_D6 101: Reserved 110: Reserved 111: IO Disable
7	/	/	/

6:4	R/W	0x7	PE9_SELECT 000: Input 010: CSI_D5 100: TS_D5 110: Reserved	001: Output 011: Reserved 101: Reserved 111: IO Disable
3	/	/	/	
2:0	R/W	0x7	PE8_SELECT 000: Input 010: CSI_D4 100: TS_D4 110: Reserved	001: Output 011: Reserved 101: Reserved 111: IO Disable

3.21.2.30. PE Configure Register 2 (Default Value: 0x00000077)

Offset: 0x98			Register Name: PE_CFG2_REG	
Bit	R/W	Default/Hex	Description	
31:7	/	/	/	
6:4	R/W	0x7	PE17_SELECT 000: Input 010: Reserved 100: Reserved 110: Reserved	001: Output 011: Reserved 101: Reserved 111: IO Disable
3	/	/	/	
2:0	R/W	0x7	PE16_SELECT 000: Input 010: Reserved 100: Reserved 110: Reserved	001: Output 011: Reserved 101: Reserved 111: IO Disable

3.21.2.31. PE Configure Register 3 (Default Value: 0x00000000)

Offset: 0x9C			Register Name: PE_CFG3_REG
Bit	R/W	Default/Hex	Description
31:0	/	/	/

3.21.2.32. PE Data Register (Default Value: 0x00000000)

Offset: 0xA0			Register Name: PE_DATA_REG
Bit	R/W	Default/Hex	Description
31:18	/	/	/

17:0	R/W	0x0	<p>PE_DAT</p> <p>If the port is configured as input, the corresponding bit is the pin state. If the port is configured as output, the pin state is the same as the corresponding bit. The read bit value is the value setup by software. If the port is configured as functional pin, the undefined value will be read.</p>
------	-----	-----	---

3.21.2.33. PE Multi-Driving Register 0 (Default Value: 0x55555555)

Offset: 0xA4			Register Name: PE_DRV0_REG
Bit	R/W	Default/Hex	Description
[2i+1:2i] (i=0~15)	R/W	0x1	<p>PE_DRV</p> <p>PE[n] Multi-Driving SELECT (n = 0~15)</p> <p>00: Level 0 01: Level 1</p> <p>10: Level 2 11: Level 3</p>

3.21.2.34. PE Multi-Driving Register 1 (Default Value: 0x00000005)

Offset: 0xA8			Register Name: PE_DRV1_REG
Bit	R/W	Default/Hex	Description
31:4	/	/	/
[2i+1:2i] (i=0~1)	R/W	0x1	<p>PE_DRV</p> <p>PE[n] Multi-Driving Select (n = 16~17)</p> <p>00: Level 0 01: Level 1</p> <p>10: Level 2 11: Level 3</p>

3.21.2.35. PE PULL Register 0 (Default Value: 0x00000000)

Offset: 0xAC			Register Name: PE_PULL0_REG
Bit	R/W	Default/Hex	Description
[2i+1:2i] (i=0~15)	R/W	0x0	<p>PE_PULL</p> <p>PE[n] Pull-up/down Select (n = 0~15)</p> <p>00: Pull-up/down disable 01: Pull-up</p> <p>10: Pull-down 11: Reserved</p>

3.21.2.36. PE PULL Register 1 (Default Value: 0x00000000)

Offset: 0xB0			Register Name: PE_PULL1_REG
Bit	R/W	Default/Hex	Description

31:4	/	/	/
[2i+1:2i] (i=0~1)	R/W	0x0	PE_PULL PE[n] Pull-up/down Select (n = 16~17) 00: Pull-up/down disable 01: Pull-up 10: Pull-down 11: Reserved

3.21.2.37. PF Configure Register 0 (Default Value: 0x07777777)

Offset: 0xB4			Register Name: PF_CFG0_REG
Bit	R/W	Default/Hex	Description
31:27	/	/	/
26:24	R/W	0x7	PF6_SELECT 000: Input 001: Output 010: Reserved 011: Reserved 100: Reserved 101: Reserved 110: Reserved 111: IO Disable
23	/	/	/
22:20	R/W	0x7	PF5_SELECT 000: Input 001: Output 010: SDC0_D2 011: JTAG_CK1 100: Reserved 101: Reserved 110: Reserved 111: IO Disable
19	/	/	/
18:16	R/W	0x7	PF4_SELECT 000: Input 001: Output 010: SDC0_D3 011: UART0_RX 100: Reserved 101: Reserved 110: Reserved 111: IO Disable
15	/	/	/
14:12	R/W	0x7	PF3_SELECT 000: Input 001: Output 010: SDC0_CMD 011: JTAG_DO1 100: Reserved 101: Reserved 110: Reserved 111: IO Disable
11	/	/	/
10:8	R/W	0x7	PF2_SELECT 000: Input 001: Output 010: SDC0_CLK 011: UART0_TX 100: Reserved 101: Reserved 110: Reserved 111: IO Disable
7	/	/	/
6:4	R/W	0x7	PF1_SELECT

			000: Input 010: SDC0_D0 100: Reserved 110: Reserved	001: Output 011: JTAG_DI1 101: Reserved 111: IO Disable
3	/	/	/	
2:0	R/W	0x7	PF0_SELECT 000: Input 010: SDC0_D1 100: Reserved 110: Reserved	001: Output 011: JTAG_MS1 101: Reserved 111: IO Disable

3.21.2.38. PF Configure Register 1 (Default Value: 0x00000000)

Offset: 0xB8			Register Name: PF_CFG1_REG
Bit	R/W	Default/Hex	Description
31:0	/	/	/

3.21.2.39. PF Configure Register 2(Default Value: 0x00000000)

Offset: 0xBC			Register Name: PF_CFG2_REG
Bit	R/W	Default/Hex	Description
31:0	/	/	/

3.21.2.40. PF Configure Register 3(Default Value: 0x00000000)

Offset: 0xC0			Register Name: PF_CFG3_REG
Bit	R/W	Default/Hex	Description
31:0	/	/	/

3.21.2.41. PF Data Register (Default Value: 0x00000000)

Offset: 0xC4			Register Name: PF_DATA_REG
Bit	R/W	Default/Hex	Description
31:7	/	/	/
6:0	R/W	0x0	PF_DAT If the port is configured as input, the corresponding bit is the pin state. If the port is configured as output, the pin state is the same as the corresponding bit. The read bit value is the value setup by software. If the

			port is configured as functional pin, the undefined value will be read.
--	--	--	---

3.21.2.42. PF Multi-Driving Register 0 (Default Value: 0x00001555)

Offset: 0xC8			Register Name: PF_DRV0_REG
Bit	R/W	Default/Hex	Description
31:14	/	/	/
[2i+1:2i] (i=0~6)	R/W	0x1	PF_DRV PF[n] Multi-Driving SELECT (n = 0~6) 00: Level 0 01: Level 1 10: Level 2 11: Level 3

3.21.2.43. PF Multi-Driving Register 1 (Default Value: 0x00000000)

Offset: 0xCC			Register Name: PF_DRV1_REG
Bit	R/W	Default/Hex	Description
31:0	/	/	/

3.21.2.44. PF PULL Register 0 (Default Value: 0x00000000)

Offset: 0xD0			Register Name: PF_PULL0_REG
Bit	R/W	Default/Hex	Description
31:14	/	/	/
[2i+1:2i] (i=0~6)	R/W	0x0	PF_PULL PF[n] Pull-up/down Select (n = 0~6) 00: Pull-up/down disable 01: Pull-up 10: Pull-down 11: Reserved

3.21.2.45. PF PULL Register 1 (Default Value: 0x00000000)

Offset: 0xD4			Register Name: PF_PULL1_REG
Bit	R/W	Default/Hex	Description
31:0	/	/	/

3.21.2.46. PG Configure Register 0 (Default Value: 0x77777777)

Offset: 0xD8			Register Name: PG_CFG0_REG
--------------	--	--	-----------------------------------

Bit	R/W	Default/Hex	Description
31	/	/	/
30:28	R/W	0x7	PG7_SELECT 000: Input 001: Output 010: UART1_RX 011: Reserved 100: Reserved 101: Reserved 110: PG_EINT7 111: IO Disable
27	/	/	/
26:24	R/W	0x7	PG6_SELECT 000: Input 001: Output 010: UART1_TX 011: Reserved 100: Reserved 101: Reserved 110: PG_EINT6 111: IO Disable
23	/	/	/
22:20	R/W	0x7	PG5_SELECT 000: Input 001: Output 010: SDC1_D3 011: Reserved 100: Reserved 101: Reserved 110: PG_EINT5 111: IO Disable
19	/	/	/
18:16	R/W	0x7	PG4_SELECT 000: Input 001: Output 010: SDC1_D2 011: Reserved 100: Reserved 101: Reserved 110: PG_EINT4 111: IO Disable
15	/	/	/
14:12	R/W	0x7	PG3_SELECT 000: Input 001: Output 010: SDC1_D1 011: Reserved 100: Reserved 101: Reserved 110: PG_EINT3 111: IO Disable
11	/	/	/
10:8	R/W	0x7	PG2_SELECT 000: Input 001: Output 010: SDC1_D0 011: Reserved 100: Reserved 101: Reserved 110: PG_EINT2 111: IO Disable
7	/	/	/
6:4	R/W	0x7	PG1_SELECT 000: Input 001: Output 010: SDC1_CMD 011: Reserved 100: Reserved 101: Reserved 110: PG_EINT1 111: IO Disable
3	/	/	/

2:0	R/W	0x7	PG0_SELECT 000: Input 010: SDC1_CLK 100: Reserved 110: PG_EINT0	001: Output 011: Reserved 101: Reserved 111: IO Disable
-----	-----	-----	---	--

3.21.2.47. PG Configure Register 1 (Default Value: 0x00777777)

Offset: 0xDC			Register Name: PG_CFG1_REG	
Bit	R/W	Default/Hex	Description	
31:23	/	/	/	
22:20	R/W	0x7	PG13_SELECT 000: Input 010: AIF3_DIN 100: Reserved 110: PG_EINT13	001: Output 011: PCM1_DIN 101: Reserved 111: IO Disable
19	/	/	/	
18:16	R/W	0x7	PG12_SELECT 000: Input 010: AIF3_DOUT 100: Reserved 110: PG_EINT12	001: Output 011: PCM1_DOUT 101: Reserved 111: IO Disable
15	/	/	/	
14:12	R/W	0x7	PG11_SELECT 000: Input 010: AIF3_BCLK 100: Reserved 110: PG_EINT11	001: Output 011: PCM1_BCLK 101: Reserved 111: IO Disable
11	/	/	/	
10:8	R/W	0x7	PG10_SELECT 000: Input 010: AIF3_SYNC 100: Reserved 110: PG_EINT10	001: Output 011: PCM1_SYNC 101: Reserved 111: IO Disable
7	/	/	/	
6:4	R/W	0x7	PG9_SELECT 000: Input 010: UART1_CTS 100: Reserved 110: PG_EINT9	001: Output 011: Reserved 101: Reserved 111: IO Disable
3	/	/	/	
2:0	R/W	0x7	PG8_SELECT	

			000: Input	001: Output
			010: UART1_RTS	011: Reserved
			100: Reserved	101: Reserved
			110: PG_EINT8	111: IO Disable

3.21.2.48. PG Configure Register 2 (Default Value: 0x00000000)

Offset: 0xE0			Register Name: PG_CFG2_REG
Bit	R/W	Default/Hex	Description
31:0	/	/	/

3.21.2.49. PG Configure Register 3 (Default Value: 0x00000000)

Offset: 0xE4			Register Name: PG_CFG3_REG
Bit	R/W	Default/Hex	Description
31:0	/	/	/

3.21.2.50. PG Data Register (Default Value: 0x00000000)

Offset: 0xE8			Register Name: PG_DATA_REG
Bit	R/W	Default/Hex	Description
31:14	/	/	/
13:0	R/W	0x0	PG_DAT If the port is configured as input, the corresponding bit is the pin state. If the port is configured as output, the pin state is the same as the corresponding bit. The read bit value is the value setup by software. If the port is configured as functional pin, the undefined value will be read.

3.21.2.51. PG Multi-Driving Register 0 (Default Value: 0x05555555)

Offset: 0xEC			Register Name: PG_DRV0_REG
Bit	R/W	Default/Hex	Description
31:28	/	/	/
[2i+1:2i] (i=0~13)	R/W	0x1	PG_DRV PG[n] Multi-Driving SELECT (n = 0~13) 00: Level 0 01: Level 1 10: Level 2 11: Level 3

3.21.2.52. PG Multi-Driving Register 1 (Default Value: 0x00000000)

Offset: 0xF0			Register Name: PG_DRV1_REG
Bit	R/W	Default/Hex	Description
31:0	/	/	/

3.21.2.53. PG PULL Register 0 (Default Value: 0x00000000)

Offset: 0xF4			Register Name: PG_PULL0_REG
Bit	R/W	Default/Hex	Description
31:28	/	/	/
[2i+1:2i] (i=0~13)	R/W	0x0	PF_PULL PF[n] Pull-up/down Select (n = 0~13) 00: Pull-up/down disable 01: Pull-up 10: Pull-down 11: Reserved

3.21.2.54. PG PULL Register 1 (Default Value: 0x00000000)

Offset: 0xF8			Register Name: PG_PULL1_REG
Bit	R/W	Default/Hex	Description
31:0	/	/	/

3.21.2.55. PH Configure Register 0 (Default Value: 0x77777777)

Offset: 0xFC			Register Name: PH_CFG0_REG
Bit	R/W	Default/Hex	Description
31	/	/	/
30:28	R/W	0x7	PH7_SELECT 000: Input 001: Output 010: UART3_CTS 011: Reserved 100: Reserved 101: Reserved 110: PH_EINT7 111: IO Disable
27	/	/	/
26:24	R/W	0x7	PH6_SELECT 000: Input 001: Output 010: UART3_RTS 011: Reserved 100: Reserved 101: Reserved 110: PH_EINT6 111: IO Disable
23	/	/	/

22:20	R/W	0x7	PH5_SELECT 000: Input 010: UART3_RX 100: Reserved 110: PH_EINT5	001: Output 011: Reserved 101: Reserved 111: IO Disable
19	/	/	/	/
18:16	R/W	0x7	PH4_SELECT 000: Input 010: UART3_TX 100: Reserved 110: PH_EINT4	001: Output 011: Reserved 101: Reserved 111: IO Disable
15	/	/	/	/
14:12	R/W	0x7	PH3_SELECT 000: Input 010: TWI1_SDA 100: Reserved 110: PH_EINT3	001: Output 011: Reserved 101: Reserved 111: IO Disable
11	/	/	/	/
10:8	R/W	0x7	PH2_SELECT 000: Input 010: TWI1_SCK 100: Reserved 110: PH_EINT2	001: Output 011: Reserved 101: Reserved 111: IO Disable
7	/	/	/	/
6:4	R/W	0x7	PH1_SELECT 000: Input 010: TWI0_SDA 100: Reserved 110: PH_EINT1	001: Output 011: Reserved 101: Reserved 111: IO Disable
3	/	/	/	/
2:0	R/W	0x7	PH0_SELECT 000: Input 010: TWI0_SCK 100: Reserved 110: PH_EINT0	001: Output 011: Reserved 101: Reserved 111: IO Disable

3.21.2.56. PH Configure Register 1 (Default Value: 0x00007777)

Offset: 0x100			Register Name: PH_CFG1_REG
Bit	R/W	Default/Hex	Description
31:15	/	/	/
14:12	R/W	0x7	PH11_SELECT

			000: Input 010: MIC_DATA 100: Reserved 110: PH_EINT11	001: Output 011: Reserved 101: Reserved 111: IO Disable
11	/	/	/	
10:8	R/W	0x7	PH10_SELECT 000: Input 010: MIC_CLK 100: Reserved 110: PH_EINT10	001: Output 011: Reserved 101: Reserved 111: IO Disable
7	/	/	/	
6:4	R/W	0x7	PH9_SELECT 000: Input 010: Reserved 100: Reserved 110: PH_EINT9	001: Output 011: Reserved 101: Reserved 111: IO Disable
3	/	/	/	
2:0	R/W	0x7	PH8_SELECT 000: Input 010: OWA_OUT 100: Reserved 110: PH_EINT8	001: Output 011: Reserved 101: Reserved 111: IO Disable

3.21.2.57. PH Configure Register 2 (Default Value: 0x00000000)

Offset: 0x104			Register Name: PH_CFG2_REG
Bit	R/W	Default/Hex	Description
31:0	/	/	/

3.21.2.58. PH Configure Register 3 (Default Value: 0x00000000)

Offset: 0x108			Register Name: PH_CFG3_REG
Bit	R/W	Default/Hex	Description
31:0	/	/	/

3.21.2.59. PH Data Register (Default Value: 0x00000000)

Offset: 0x10C			Register Name: PH_DATA_REG
Bit	R/W	Default/Hex	Description
31:12	/	/	/

11:0	R/W	0	PH_DAT If the port is configured as input, the corresponding bit is the pin state. If the port is configured as output, the pin state is the same as the corresponding bit. The read bit value is the value setup by software. If the port is configured as functional pin, the undefined value will be read.
------	-----	---	---

3.21.2.60. PH Multi-Driving Register 0 (Default Value: 0x00555555)

Offset: 0x110			Register Name: PH_DRV0_REG
Bit	R/W	Default/Hex	Description
31:24	/	/	/
[2i+1:2i] (i=0~11)	R/W	0x1	PH_DRV PH[n] Multi-Driving Select (n = 0~11) 00: Level 0 01: Level 1 10: Level 2 11: Level 3

3.21.2.61. PH Multi-Driving Register 1 (Default Value: 0x00000000)

Offset: 0x114			Register Name: PH_DRV1_REG
Bit	R/W	Default/Hex	Description
31:0	/	/	/

3.21.2.62. PH PULL Register 0 (Default Value: 0x00000000)

Offset: 0x118			Register Name: PH_PULL0_REG
Bit	R/W	Default/Hex	Description
31:24	/	/	/
[2i+1:2i] (i=0~11)	R/W	0	PH_PULL PH[n] Pull-up/down Select (n = 0~11) 00: Pull-up/down disable 01: Pull-up 10: Pull-down 11: Reserved

3.21.2.63. PH PULL Register 1 (Default Value: 0x00000000)

Offset: 0x11C			Register Name: PH_PULL1_REG
Bit	R/W	Default/Hex	Description
31:0	/	/	/

3.21.2.64. PB External Interrupt Configure Register 0 (Default Value: 0x00000000)

Offset: 0x200			Register Name: PB_EINT_CFG0_REG
Bit	R/W	Default/Hex	Description
[4i+3:4i] (i=0~7)	R/W	0	EINT_CFG External INTn Mode (n = 0~7) 0x0: Positive Edge 0x1: Negative Edge 0x2: High Level 0x3: Low Level 0x4: Double Edge (Positive/ Negative) Others: Reserved

3.21.2.65. PB External Interrupt Configure Register 1 (Default Value: 0x00000000)

Offset: 0x204			Register Name: PB_EINT_CFG1_REG
Bit	R/W	Default/Hex	Description
31:8	/	/	/
[4i+3:4i] (i=0~1)	R/W	0	EINT_CFG External INTn Mode (n = 8~9) 0x0: Positive Edge 0x1: Negative Edge 0x2: High Level 0x3: Low Level 0x4: Double Edge (Positive/ Negative) Others: Reserved

3.21.2.66. PB External Interrupt Configure Register 2 (Default Value: 0x00000000)

Offset: 0x208			Register Name: PB_EINT_CFG2_REG
Bit	R/W	Default/Hex	Description
31:0	/	/	/

3.21.2.67. PB External Interrupt Configure Register 3 (Default Value: 0x00000000)

Offset: 0x20C			Register Name: PB_EINT_CFG3_REG
Bit	R/W	Default/Hex	Description

31:0	/	/	/
------	---	---	---

3.21.2.68. PB External Interrupt Control Register (Default Value: 0x00000000)

Offset: 0x210			Register Name: PB_EINT_CTL_REG
Bit	R/W	Default/Hex	Description
31:10	/	/	/
[n] (n=0~9)	R/W	0	EINT_CTL External INTn Enable (n = 0~9) 0: Disable 1: Enable

3.21.2.69. PB External Interrupt Status Register (Default Value: 0x00000000)

Offset: 0x214			Register Name: PB_EINT_STATUS_REG
Bit	R/W	Default/Hex	Description
31:10	/	/	/
[n] (n=0~9)	R/W	0	EINT_STATUS External INTn Pending Bit (n = 0~9) 0: No IRQ pending 1: IRQ pending Write '1' to clear

3.21.2.70. PB External Interrupt Debounce Register (Default Value: 0x00000000)

Offset: 0x218			Register Name: PB_EINT_DEB_REG
Bit	R/W	Default/Hex	Description
31:7	/	/	/
6:4	R/W	0	DEB_CLK_PRE_SCALE Debounce Clock Pre-scale n The selected clock source is prescaled by 2^n.
3:1	/	/	/
0	R/W	0	PIO_INT_CLK_SELECT PIO Interrupt Clock Select 0: LOSC 32Khz 1: HOSC 24Mhz

3.21.2.71. PG External Interrupt Configure Register 0 (Default Value: 0x00000000)

Offset: 0x220			Register Name: PG_EINT_CFG0_REG
Bit	R/W	Default/Hex	Description
[4i+3:4i] (i=0~7)	R/W	0	EINT_CFG External INTn Mode (n = 0~7) 0x0: Positive Edge 0x1: Negative Edge 0x2: High Level 0x3: Low Level 0x4: Double Edge (Positive/ Negative) Others: Reserved

3.21.2.72. PG External Interrupt Configure Register 1 (Default Value: 0x00000000)

Offset: 0x224			Register Name: PG_EINT_CFG1_REG
Bit	R/W	Default/Hex	Description
31:24	/	/	/
[4i+3:4i] (i=0~5)	R/W	0	EINT_CFG External INTn Mode (n = 8~13) 0x0: Positive Edge 0x1: Negative Edge 0x2: High Level 0x3: Low Level 0x4: Double Edge (Positive/ Negative) Others: Reserved

3.21.2.73. PG External Interrupt Configure Register 2 (Default Value: 0x00000000)

Offset: 0x228			Register Name: PG_EINT_CFG2_REG
Bit	R/W	Default/Hex	Description
31:0	/	/	/

3.21.2.74. PG External Interrupt Configure Register 3 (Default Value: 0x00000000)

Offset: 0x22C			Register Name: PG_EINT_CFG3_REG
Bit	R/W	Default/Hex	Description
31:0	/	/	/

3.21.2.75. PG External Interrupt Control Register (Default Value: 0x00000000)

Offset: 0x230			Register Name: PG_EINT_CTL_REG
Bit	R/W	Default/Hex	Description
31:14	/	/	/
[n] (n=0~13)	R/W	0	EINT_CTL External INTn Enable (n = 0~13) 0: Disable 1: Enable

3.21.2.76. PG External Interrupt Status Register (Default Value: 0x00000000)

Offset: 0x234			Register Name: PG_EINT_STATUS_REG
Bit	R/W	Default/Hex	Description
31:14	/	/	/
[n] (n=0~13)	R/W	0	EINT_STATUS External INTn Pending Bit (n = 0~13) 0: No IRQ pending 1: IRQ pending Write '1' to clear

3.21.2.77. PG External Interrupt Debounce Register (Default Value: 0x00000000)

Offset: 0x238			Register Name: PG_EINT_DEB_REG
Bit	R/W	Default/Hex	Description
31:7	/	/	/
6:4	R/W	0	DEB_CLK_PRE_SCALE Debounce Clock Pre-scale n The selected clock source is prescaled by 2^n.
3:1	/	/	/
0	R/W	0	PIO_INT_CLK_SELECT PIO Interrupt Clock Select 0: LOSC 32Khz 1: HOSC 24Mhz

3.21.2.78. PH External Interrupt Configure Register 0 (Default Value: 0x00000000)

Offset: 0x240			Register Name: PH_EINT_CFG0_REG
Bit	R/W	Default/Hex	Description

[4i+3:4i] (i=0~7)	R/W	0	EINT_CFG External INTn Mode (n = 0~7) 0x0: Positive Edge 0x1: Negative Edge 0x2: High Level 0x3: Low Level 0x4: Double Edge (Positive/ Negative) Others: Reserved
----------------------	-----	---	--

3.21.2.79. PH External Interrupt Configure Register 1 (Default Value: 0x00000000)

Offset: 0x244			Register Name: PH_EINT_CFG1_REG
Bit	R/W	Default/Hex	Description
31:16	/	/	/
[4i+3:4i] (i=0~3)	R/W	0	ENT_CFG External INTn Mode (n = 8~11) 0x0: Positive Edge 0x1: Negative Edge 0x2: High Level 0x3: Low Level 0x4: Double Edge (Positive/ Negative) Others: Reserved

3.21.2.80. PH External Interrupt Configure Register2 (Default Value: 0x00000000)

Offset: 0x248			Register Name: PH_EINT_CFG2_REG
Bit	R/W	Default/Hex	Description
31:0	/	/	/

3.21.2.81. PH External Interrupt Configure Register3 (Default Value: 0x00000000)

Offset: 0x24C			Register Name: PH_EINT_CFG3_REG
Bit	R/W	Default/Hex	Description
31:0	/	/	/

3.21.2.82. PH External Interrupt Control Register (Default Value: 0x00000000)

Offset: 0x250	Register Name: PH_EINT_CTL_REG
---------------	---------------------------------------

Bit	R/W	Default/Hex	Description
31:14	/	/	/
[n] (n=0~11)	R/W	0	EINT_CTL External INTn Enable (n = 0~11) 0: Disable 1: Enable

3.21.2.83. PH External Interrupt Status Register (Default Value: 0x00000000)

Offset: 0x254			Register Name: PH_EINT_STATUS_REG
Bit	R/W	Default/Hex	Description
31:12	/	/	/
[n] (n=0~11)	R/W	0	EINT_STATUS External INTn Pending Bit (n = 0~11) 0: No IRQ pending 1: IRQ pending Write '1' to clear

3.21.2.84. PH External Interrupt Debounce Register (Default Value: 0x00000000)

Offset: 0x258			Register Name: PH_EINT_DEB_REG
Bit	R/W	Default/Hex	Description
31:7	/	/	/
6:4	R/W	0	DEB_CLK_PRE_SCALE Debounce Clock Pre-scale n The selected clock source is prescaled by 2^n.
3:1	/	/	/
0	R/W	0	PIO_INT_CLK_SELECT PIO Interrupt Clock Select 0: LOSC 32Khz 1: HOSC 24Mhz

3.22. Port Controller(CPUs-PORT)

The chip has 1 port for multi-functional input/out pins. They are shown below:

- Port L(PL):13 input/output port

For various system configurations, these ports can be easily configured by software. All these ports can be configured as GPIO if multiplexed functions not used. The one group external PIO interrupt sources are supported and interrupt mode can be configured by software.

3.22.1. Port Controller Register List

Module Name	Base Address
PIO	0x01F02C00

Register Name	Offset	Description
PL_CFG0	0*0x24+0x00	Port L Configure Register 0
PL_CFG1	0*0x24+0x04	Port L Configure Register 1
PL_CFG2	0*0x24+0x08	Port L Configure Register 2
PL_CFG3	0*0x24+0x0C	Port L Configure Register 3
PL_DAT	0*0x24+0x10	Port L Data Register
PL_DRV0	0*0x24+0x14	Port L Multi-Driving Register 0
PL_DRV1	0*0x24+0x18	Port L Multi-Driving Register 1
PL_PUL0	0*0x24+0x1C	Port L Pull Register 0
PL_PUL1	0*0x24+0x20	Port L Pull Register 1
PL_INT_CFG0	0x200+0*0x20+0x00	PIO Interrupt Configure Register 0
PL_INT_CFG1	0x200+0*0x20+0x04	PIO Interrupt Configure Register 1
PL_INT_CFG2	0x200+0*0x20+0x08	PIO Interrupt Configure Register 2
PL_INT_CFG3	0x200+0*0x20+0x0C	PIO Interrupt Configure Register 3
PL_INT_CTL	0x200+0*0x20+0x10	PIO Interrupt Control Register
PL_INT_STA	0x200+0*0x20+0x14	PIO Interrupt Status Register
PL_INT_DEB	0x200+0*0x20+0x18	PIO Interrupt Debounce Register

3.22.2. Port Controller Register Description

3.22.2.1. PL Configure Register 0 (Default Value: 0x77777777)

Offset: 0x00		Register Name: PL_CFG0_REG	
Bit	R/W	Default/Hex	Description

31	/	/	/
30:28	R/W	0x7	PL7_SELECT 000: Input 001: Output 010: S_JTAG_DI 011: Reserved 100: Reserved 101: Reserved 110: S_PL_EINT7 111: IO Disable
27	/	/	/
26:24	R/W	0x7	PL6_SELECT 000: Input 001: Output 010: S_JTAG_DO 011: Reserved 100: Reserved 101: Reserved 110: S_PL_EINT6 111: IO Disable
23	/	/	/
22:20	R/W	0x7	PL5_SELECT 000: Input 001: Output 010: S_JTAG_CK 011: Reserved 100: Reserved 101: Reserved 110: S_PL_EINT5 111: IO Disable
19	/	/	/
18:16	R/W	0x7	PL4_SELECT 000: Input 001: Output 010: S_JTAG_MS 011: Reserved 100: Reserved 101: Reserved 110: S_PL_EINT4 111: IO Disable
15	/	/	/
14:12	R/W	0x7	PL3_SELECT 000: Input 001: Output 010: S_UART_RX 011: Reserved 100: Reserved 101: Reserved 110: S_PL_EINT3 111: IO Disable
11	/	/	/
10:8	R/W	0x7	PL2_SELECT 000: Input 001: Output 010: S_UART_TX 011: Reserved 100: Reserved 101: Reserved 110: S_PL_EINT2 111: IO Disable
7	/	/	/
6:4	R/W	0x7	PL1_SELECT 000: Input 001: Output 010: S_RSB_SDA 011: S_TWI_SDA 100: Reserved 101: Reserved 110: S_PL_EINT1 111: IO Disable
3	/	/	/
2:0	R/W	0x7	PL0_SELECT

			000: Input 010: S_RSB_SCK 100: Reserved 110: S_PL_EINT0	001: Output 011: S_TWI_SCK 101: Reserved 111: IO Disable
--	--	--	--	---

3.22.2.2. PL Configure Register 1 (Default Value: 0x00077777)

Offset: 0x04			Register Name: PL_CFG1_REG
Bit	R/W	Default/Hex	Description
31:19	/	/	/
18:16	R/W	0x7	PL12_SELECT 000: Input 010: Reserved 100: Reserved 110: S_PL_EINT12 001: Output 011: Reserved 101: Reserved 111: IO Disable
15	/	/	/
14:12	R/W	0x7	PL11_SELECT 000: Input 010: S_CIR_RX 100: Reserved 110: S_PL_EINT11 001: Output 011: Reserved 101: Reserved 111: IO Disable
11	/	/	/
10:8	R/W	0x7	PL10_SELECT 000: Input 010: S_PWM 100: Reserved 110: S_PL_EINT10 001: Output 011: Reserved 101: Reserved 111: IO Disable
7	/	/	/
6:4	R/W	0x7	PL9_SELECT 000: Input 010: S_TWI_SDA 100: Reserved 110: S_PL_EINT9 001: Output 011: Reserved 101: Reserved 111: IO Disable
3	/	/	/
2:0	R/W	0x7	PL8_SELECT 000: Input 010: S_TWI_SCK 100: Reserved 110: S_PL_EINT8 001: Output 011: Reserved 101: Reserved 111: IO Disable

3.22.2.3. PL Configure Register 2 (Default Value: 0x00000000)

Offset: 0x08			Register Name: PL_CFG2_REG
Bit	R/W	Default/Hex	Description
31:0	/	/	/

3.22.2.4. PL Configure Register 3 (Default Value: 0x00000000)

Offset: 0x0C			Register Name: PL_CFG3_REG
Bit	R/W	Default/Hex	Description
31:0	/	/	/

3.22.2.5. PL Data Register (Default Value: 0x00000000)

Offset: 0x10			Register Name: PL_DATA_REG
Bit	R/W	Default/Hex	Description
31:13	/	/	/
12:0	R/W	0	PL_DAT If the port is configured as input, the corresponding bit is the pin state. If the port is configured as output, the pin state is the same as the corresponding bit. The read bit value is the value setup by software. If the port is configured as functional pin, the undefined value will be read.

3.22.2.6. PL Multi-Driving Register 0 (Default Value: 0x01555555)

Offset: 0x14			Register Name: PL_DRV0
Bit	R/W	Default/Hex	Description
31:26	/	/	/
$[2i+1:2i]$ (i=0~12)	R/W	0x1	PL_DRV PL[n] Multi-Driving Select (n = 0~12) 00: Level 0 01: Level 1 10: Level 2 11: Level 3

3.22.2.7. PL Multi-Driving Register 1 (Default Value: 0x00000000)

Offset: 0x18			Register Name: PL_DRV1
Bit	R/W	Default/Hex	Description
31:0	/	/	/

3.22.2.8. PL PULL Register 0 (Default Value: 0x00000005)

Offset: 0x1C			Register Name: PL_PULL0
Bit	R/W	Default/Hex	Description
31:26	/	/	/
[2i+1:2i] (i=0~12)	R/W	0x5	PL_PULL PL[n] Pull-up/down Select (n = 0~12) 00: Pull-up/down disable 01: Pull-up 10: Pull-down 11: Reserved

3.22.2.9. PL PULL Register 1 (Default Value: 0x00000000)

Offset: 0x20			Register Name: PL_PULL1
Bit	R/W	Default/Hex	Description
31:0	/	/	/

3.22.2.10. PL External Interrupt Configure Register 0 (Default Value: 0x00000000)

Offset: 0x200			Register Name: PL_EINT_CFG0
Bit	R/W	Default/Hex	Description
[4i+3:4i] (i=0~7)	R/W	0	EINT_CFG External INTn Mode (n = 0~7) 0x0: Positive Edge 0x1: Negative Edge 0x2: High Level 0x3: Low Level 0x4: Double Edge (Positive/ Negative) Others: Reserved

3.22.2.11. PL External Interrupt Configure Register 1 (Default Value: 0x00000000)

Offset: 0x204			Register Name: PL_EINT_CFG1
Bit	R/W	Default/Hex	Description
31:20	/	/	/
[4i+3:4i] (i=0~4)	R/W	0	EINT_CFG External INTn Mode (n = 8~12) 0x0: Positive Edge 0x1: Negative Edge 0x2: High Level

			0x3: Low Level 0x4: Double Edge (Positive/ Negative) Others: Reserved
--	--	--	---

3.22.2.12. PL External Interrupt Configure Register 2 (Default Value: 0x00000000)

Offset: 0x208			Register Name: PL_EINT_CFG2
Bit	R/W	Default/Hex	Description
31:0	/	/	/

3.22.2.13. PL External Interrupt Configure Register 3 (Default Value: 0x00000000)

Offset: 0x20C			Register Name: PL_EINT_CFG3
Bit	R/W	Default/Hex	Description
31:0	/	/	/

3.22.2.14. PL External Interrupt Control Register (Default Value: 0x00000000)

Offset: 0x210			Register Name: PL_EINT_CTL
Bit	R/W	Default/Hex	Description
31:13	/	/	/
[n] (n=0~12)	R/W	0	EINT_CTL External INTn Enable (n = 0~12) 0: Disable 1: Enable

3.22.2.15. PL External Interrupt Status Register (Default Value: 0x00000000)

Offset: 0x214			Register Name: PL_EINT_STATUS
Bit	R/W	Default/Hex	Description
31:13	/	/	/
[n] (n=0~12)	R/W	0	EINT_STATUS External INTn Pending Bit (n = 0~12) 0: No IRQ pending 1: IRQ pending Write '1' to clear

3.22.2.16. PL External Interrupt Debounce Register (Default Value: 0x00000000)

Offset: 0x218			Register Name: PL_EINT_DEB
Bit	R/W	Default/Hex	Description
31:7	/	/	/
6:4	R/W	0	DEB_CLK_PRE_SCALE Debounce Clock Pre-scale n The selected clock source is prescaled by 2 ⁿ .
3:1	/	/	/
0	R/W	0	PIO_INT_CLK_SELECT PIO Interrupt Clock Select 0: LOSC 32KHz 1: HOSC 24MHz

Chapter 4 Memory

This section describes the A64 memory from three aspects:

- [SDRAM](#)
- [NAND Flash](#)
- [SD-MMC Host Controller](#)

4.1. SDRAM

4.1.1. Overview

The SDRAM Controller (DRAMC) provides a simple, flexible, burst-optimized interface to all industry-standard SDRAM. It supports up to a 32G bits memory address space.

The DRAMC automatically handles memory management, initialization, and refresh operations. It gives the host CPU a simple command interface, hiding details of the required address, page, and burst handling procedures. All memory parameters are runtime-configurable, including timing, memory setting, SDRAM type, and Extended-Mode-Register settings. To simplify chip system integration, DDR controller works in half rate mode.

The DRAMC includes the following features:

- 32-bits data width
- Support 2 Chip Select
- Support DDR2/DDR3/DDR3L/LPDDR2/LPDDR3 SDRAM
- Support Different Memory Device's Power Voltage of 1.2V 1.35V 1.5V and 1.8V
- Support clock frequency up to 667 MHz(DDR3-1333)
- Support Memory Capacity up to 24G bits (3G Bytes)
- Support 16 address lines and three bank address lines per channel
- Automatically generates initialization and refresh sequences
- Runtime-configurable parameters setting for application flexibility
- Clock frequency can be chosen for different application(MDFS supported)
- Priority of transferring through multiple ports is programmable
- Random read or write operation is supported

4.2. NAND Flash Controller(NDFC)

4.2.1. Overview

The NDFC is the NAND Flash Controller which supports all NAND flash memory available in the market. New type flash can be supported by software re-configuration.

The On-the-fly error correction code (ECC) is built-in NDFC for enhancing reliability. BCH is implemented and it can detect and correct up to 64 bits error per 512 or 1024 bytes data. The on chip ECC and parity checking circuitry of NDFC frees CPU for other tasks. The ECC function can be disabled by software.

The data can be transferred by DMA or by CPU memory-mapped IO method. The NDFC provides automatic timing control for reading or writing external Flash. The NDFC maintains the proper relativity for CLE, CE# and ALE control signal lines. Three modes are supported for serial read access. The conventional serial access is mode 0 and mode 1 is for EDO type and mode 2 for extension EDO type. NDFC can monitor the status of R/B# signal line.

Block management and wear leveling management are implemented in software.

The NDFC includes the following features:

- Supports all SLC/MLC/TLC flash and EF-NAND memory available in the market
- Software configure seed for randomize engine
- Software configure method for adaptability to a variety of system and memory types
- Supports 8-bit Data Bus Width
- Supports 1024, 2048, 4096, 8192, 16384 bytes size per page
- Supports Conventional and EDO serial access method for serial reading Flash
- On-the-fly BCH error correction code which correcting up to 64 bits per 512 or 1024 bytes
- Corrected Error bits number information report
- ECC automatic disable function for all 0xff data
- NDFC status information is reported by its' registers and interrupt is supported
- One Command FIFO
- Embedded DMA to do data transfer
- External DMA is also supported for transferring data
- Two 256x32-bit RAM for Pipeline Procession
- Support SDR, ONFI DDR and Toggle DDR NAND
- Support self-debug for NDFC debug

4.2.2. Block Diagram

The NDFC system block diagram is shown below:

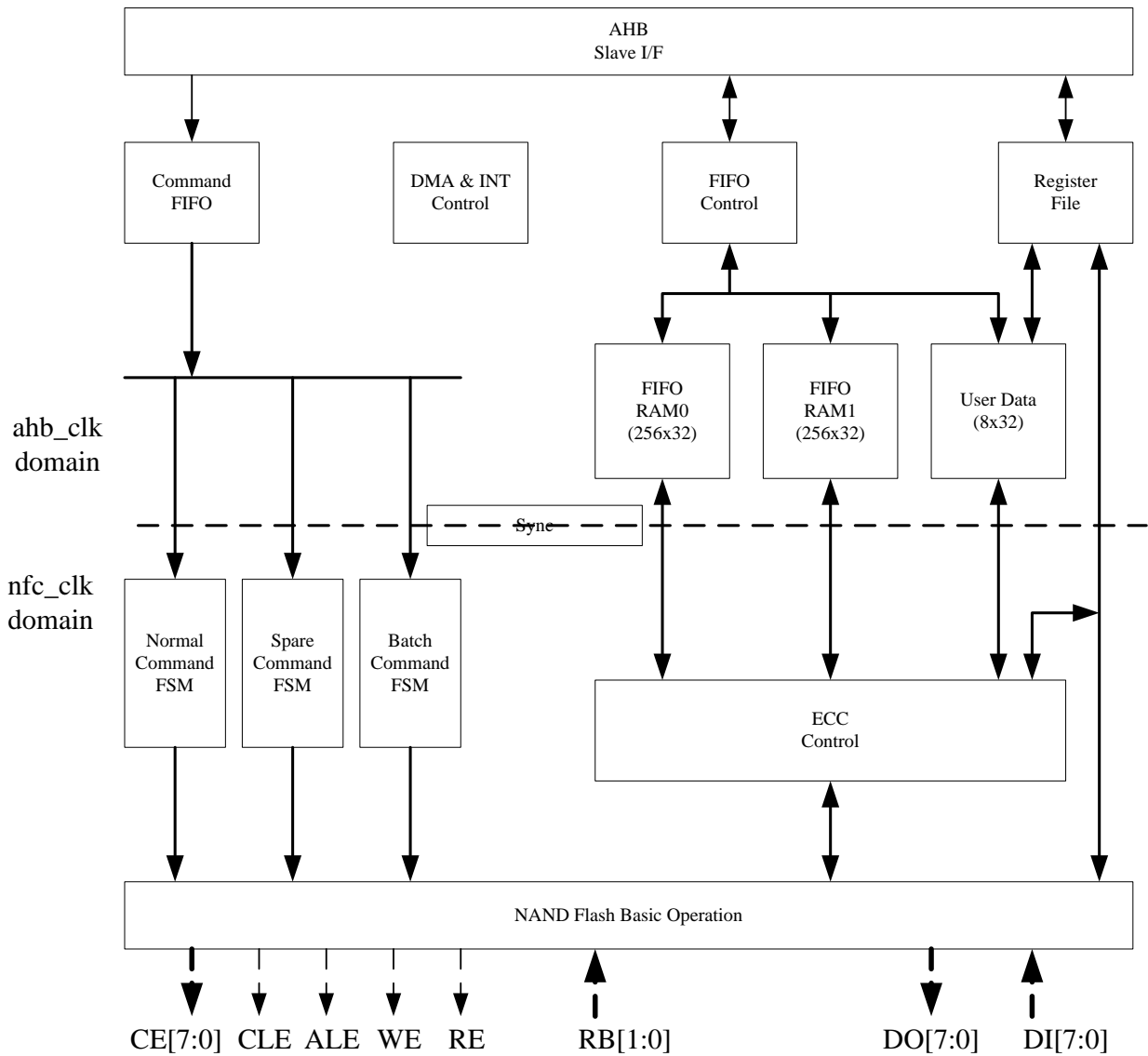

Figure 4-1. NDFC Block Diagram

4.2.3. NDFC Timing Diagram

Typically, there are two kinds of serial access method. One method is conventional method which fetching data at the rise edge of NDFC_RE# signal line. Another one is EDO type which fetching data at the next fall edge of NDFC_RE# signal line.

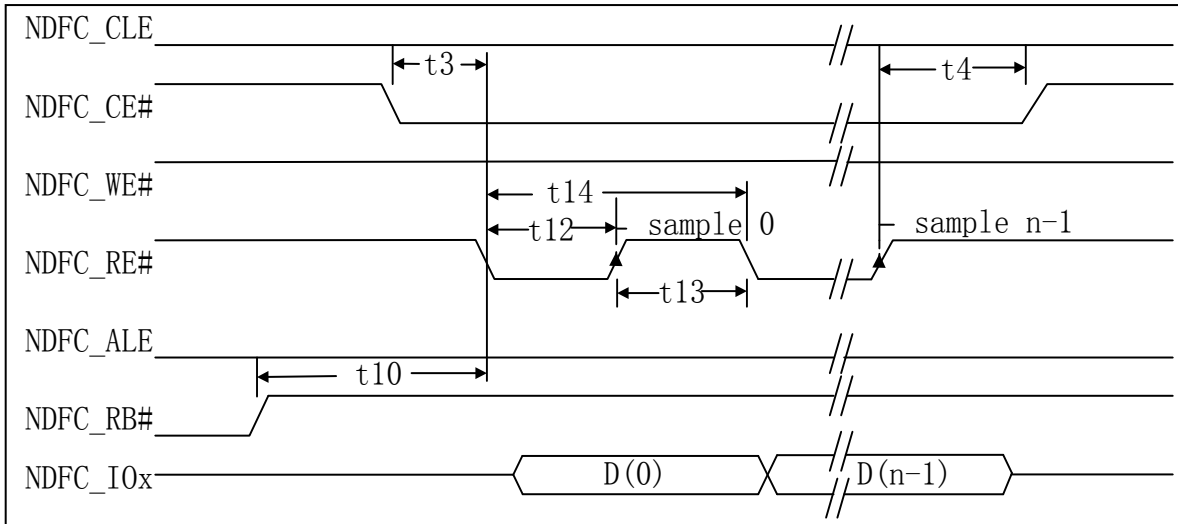

Figure 4-2. Conventional Serial Access Cycle Diagram (SAM0)

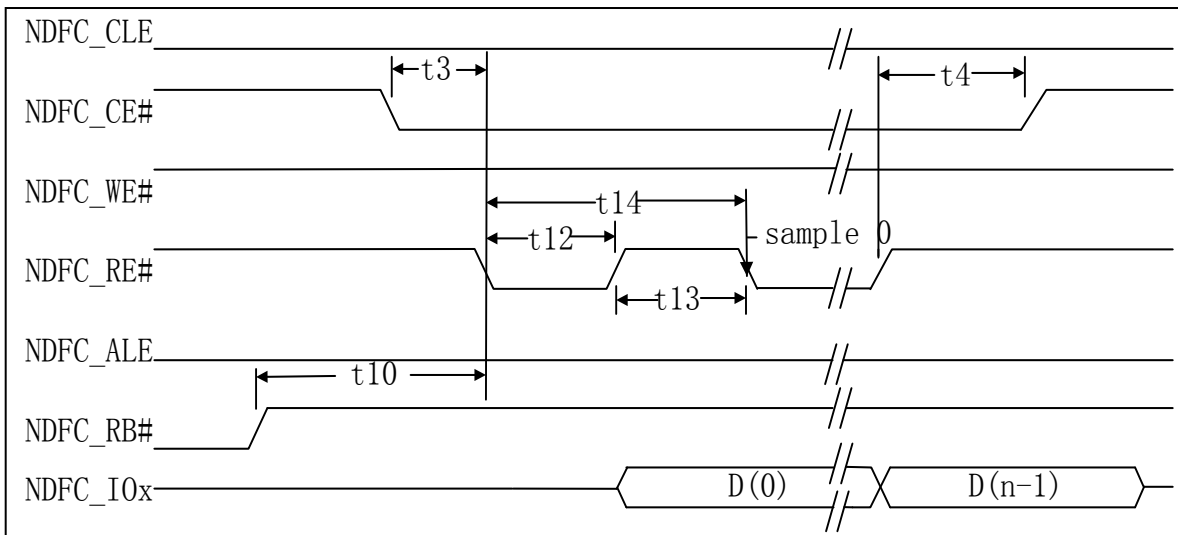

Figure 4-3. EDO type Serial Access after Read Cycle (SAM1)

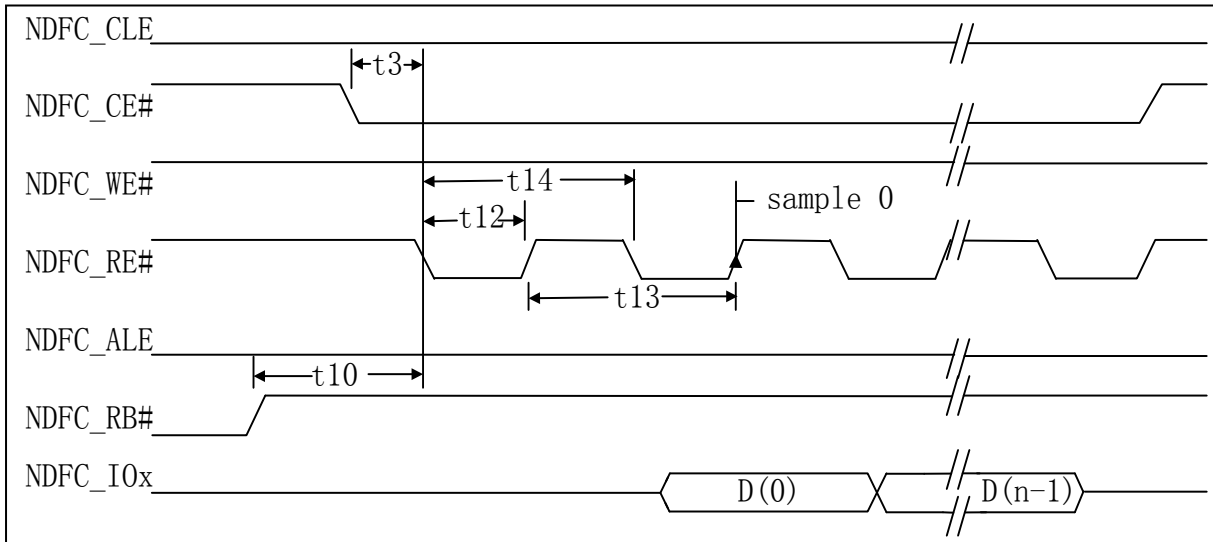

Figure 4-4. Extending EDO type Serial Access Mode (SAM2)

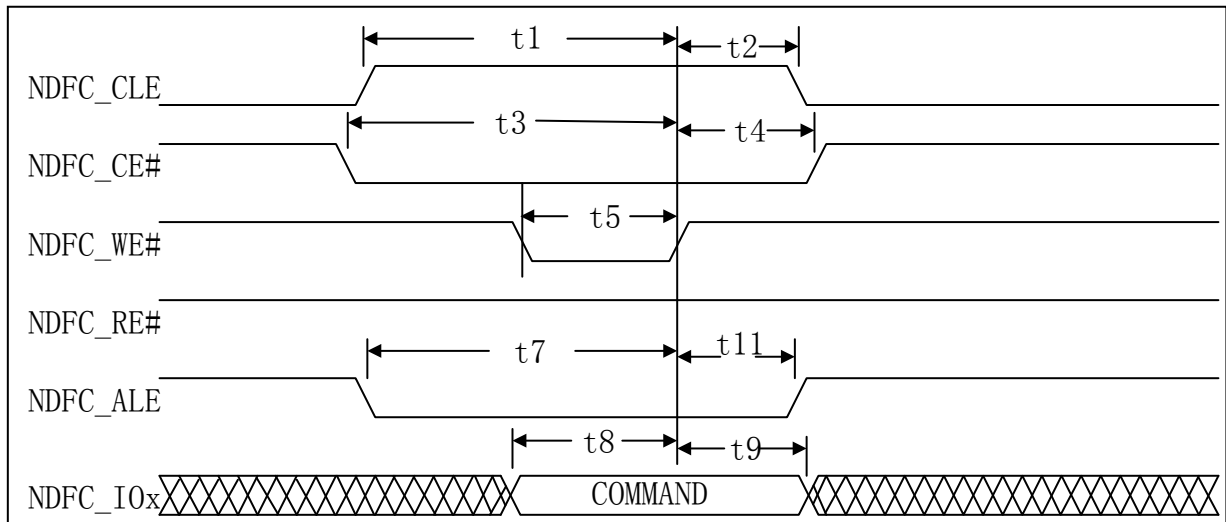

Figure 4-5. Command Latch Cycle

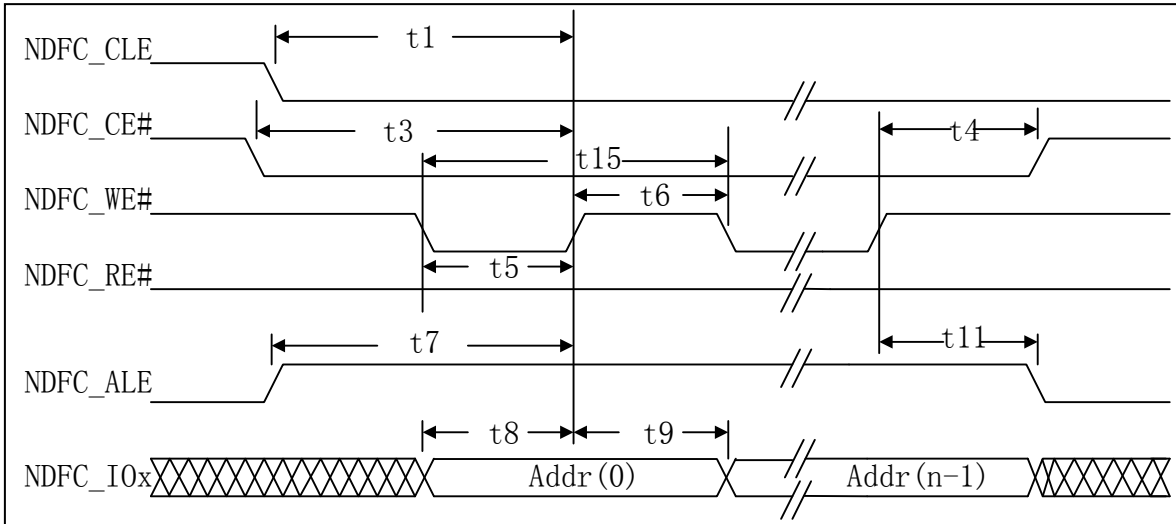

Figure 4-6. Address Latch Cycle

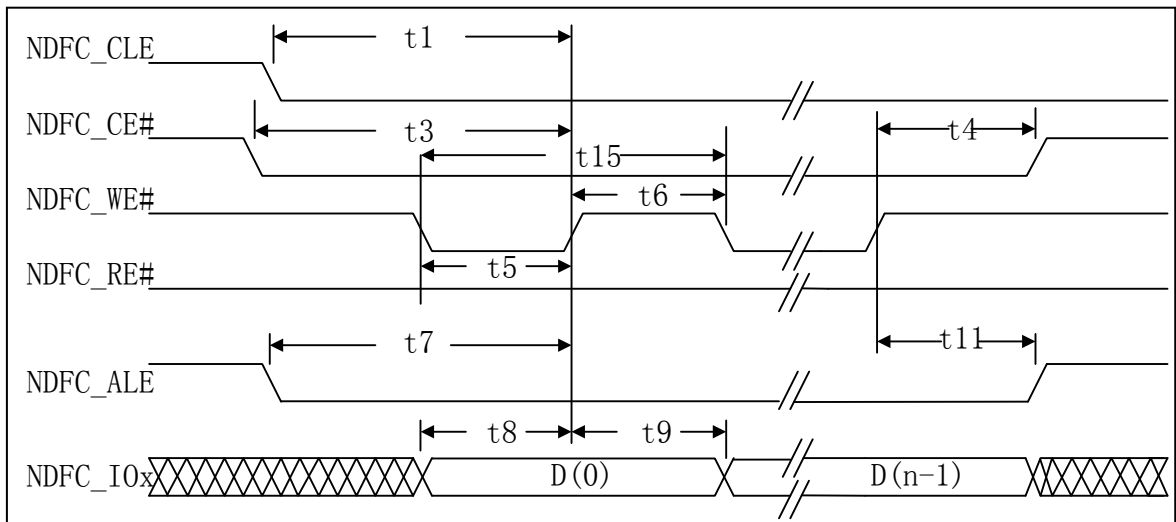

Figure 4-7. Write Data to Flash Cycle

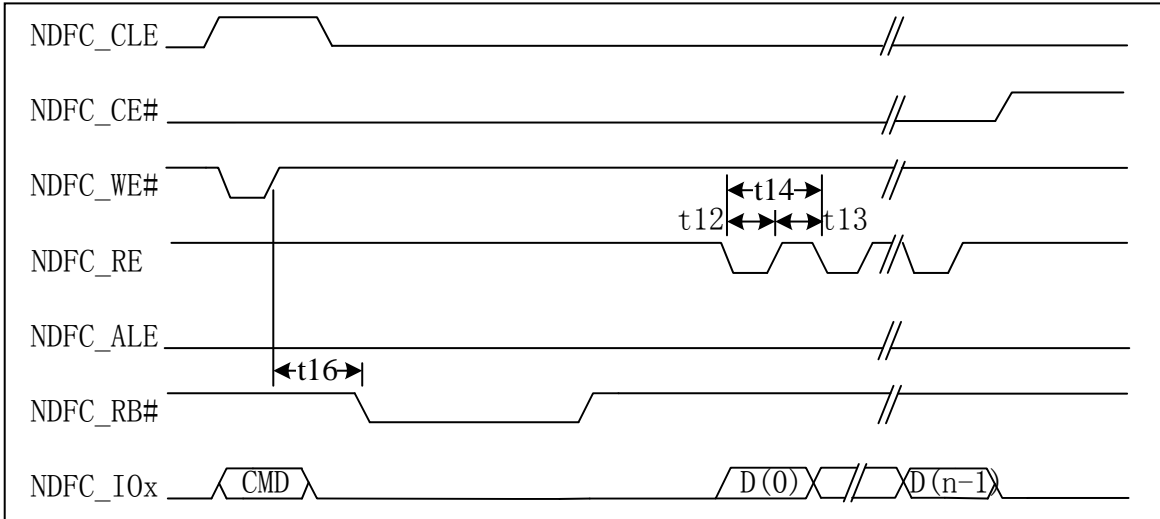

Figure 4-8. Waiting R/B# ready Diagram

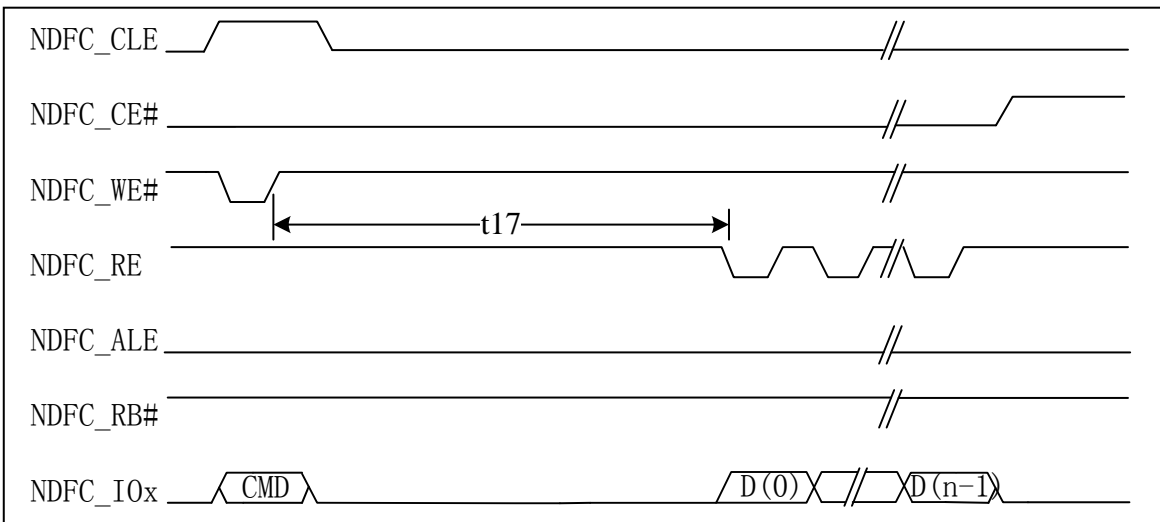

Figure 4-9. WE# high to RE# low Timing Diagram

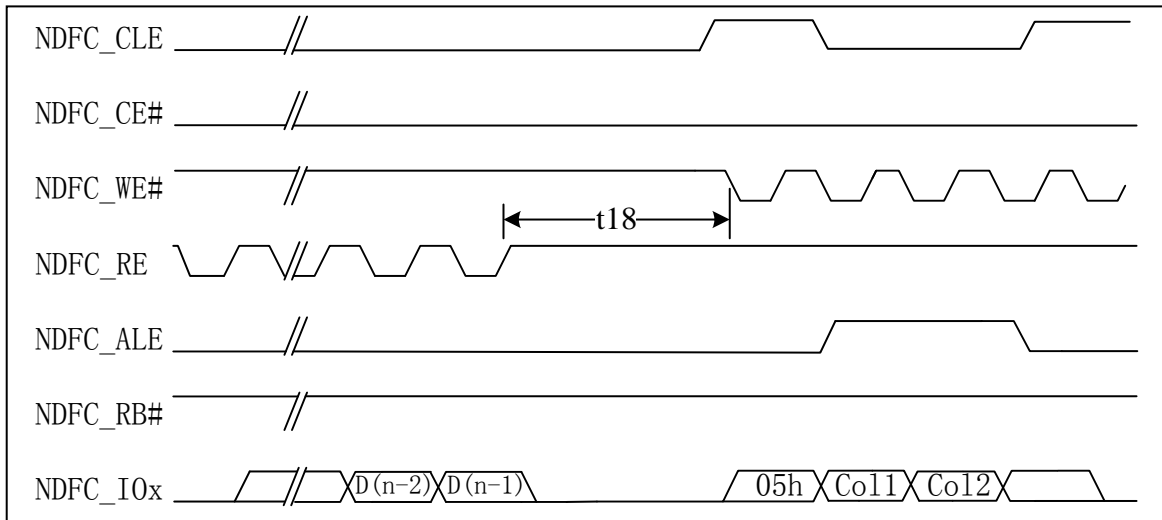

Figure 4-10. RE# high to WE# low Timing Diagram

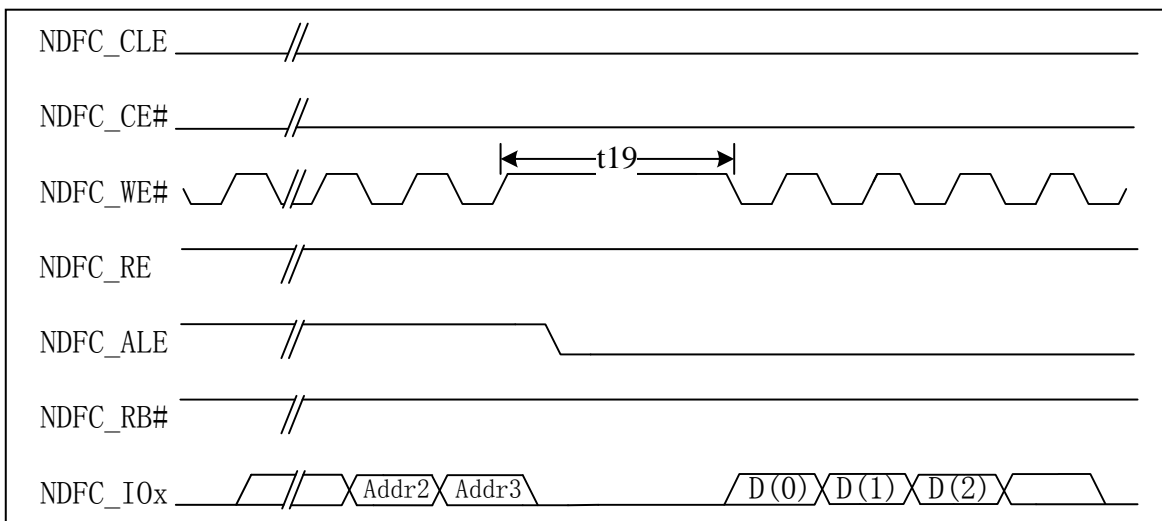

Figure 4-11. Address to Data Loading Timing Diagram

Timing cycle list:

ID	Parameter	Timing	Notes
t1	NDFC_CLE setup time	2T	
t2	NDFC_CLE hold time	2T	
t3	NDFC_CE setup time	2T	
t4	NDFC_CE hold time	2T	
t5	NDFC_WE# pulse width	T	
t6	NDFC_WE# hold time	T	
t7	NDFC_ALE setup time	2T	
t8	Data setup time	T	
t9	Data hold time	T	
t10	Ready to NDFC_RE# low	3T	
t11	NDFC_ALE hold time	2T	
t12	NDFC_RE# pulse width	T	
t13	NDFC_RE# hold time	T	
t14	Read cycle time	2T	
t15	Write cycle time	2T	
t16	NDFC_WE# high to R/B# busy	T_WB	Specified by timing configure register (NDFC_TIMING_CFG)
t17	NDFC_WE# high to NDFC_RE# low	T_WHR	Specified by timing configure register (NDFC_TIMING_CFG)
t18	NDFC_RE# high to NDFC_WE# low	T_RHW	Specified by timing configure register (NDFC_TIMING_CFG)
t19	Address to Data Loading time	T_ADL	Specified by timing configure register (NDFC_TIMING_CFG)

Notes: T is the clock period duration of NDFC_CLK (x1).

4.2.4. NDFC Operation Guide

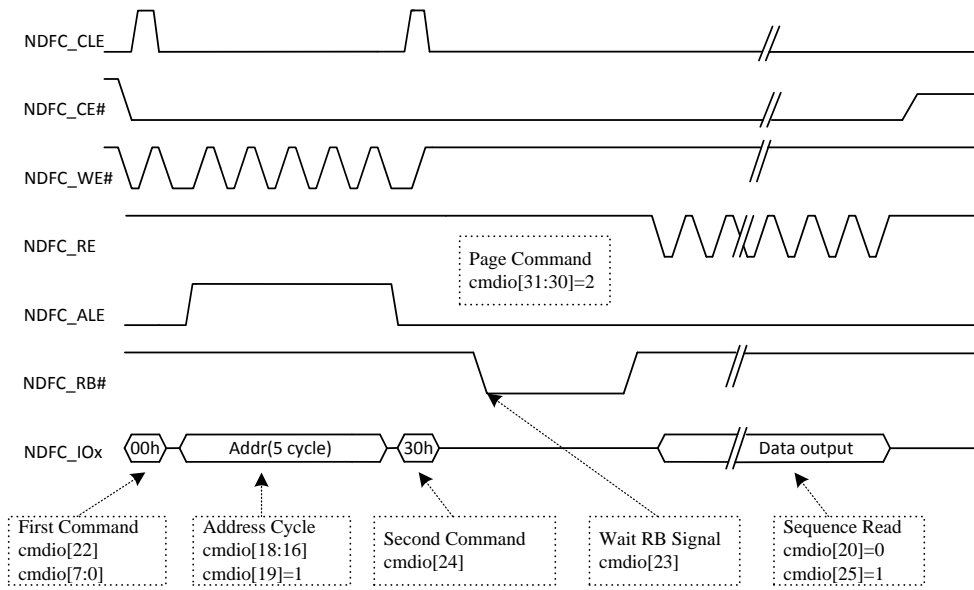

Figure 4-12. Page Read Command Diagram

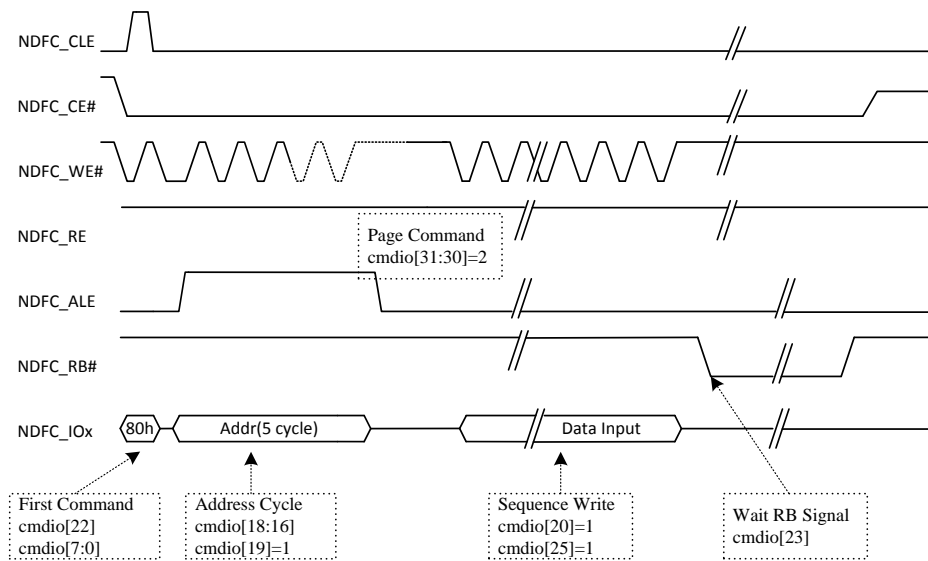

Figure 4-13. Page Program Diagram

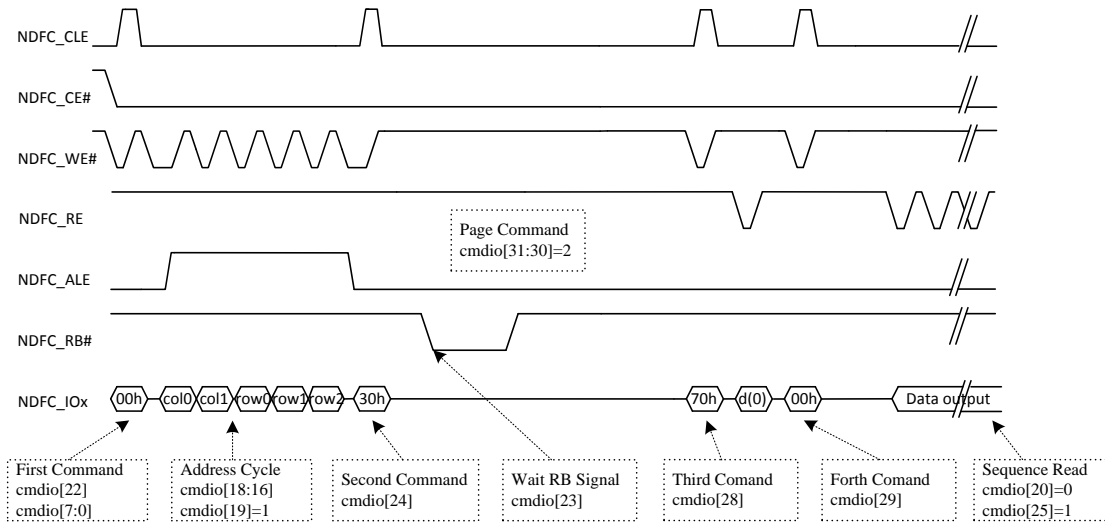

Figure 4-14. EF-NAND Page Read Diagram

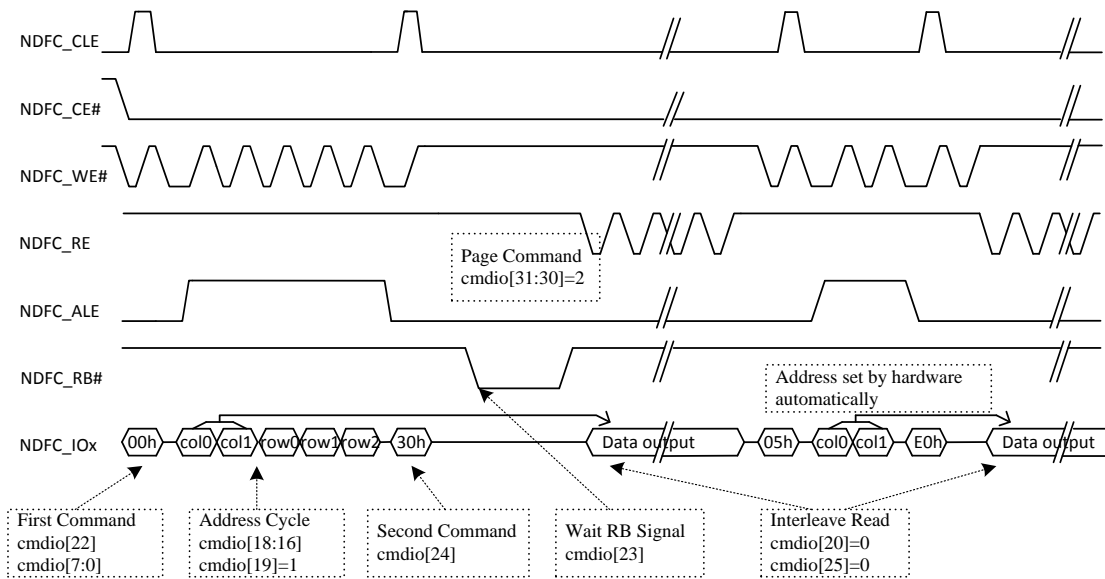

Figure 4-15. Interleave Page Read Diagram

4.2.5. NDFC Register List

Module Name	Base Address
NDFC	0x01C03000

Register Name	Offset	Description
NDFC_CTL	0x00	NDFC Configure and Control Register
NDFC_ST	0x04	NDFC Status Information Register
NDFC_INT	0x08	NDFC Interrupt Control Register

NDFC_TIMING_CTL	0x0C	NDFC Timing Control Register
NDFC_TIMING_CFG	0x10	NDFC Timing Configure Register
NDFC_ADDR_LOW	0x14	NDFC Low Word Address Register
NDFC_ADDR_HIGH	0x18	NDFC High Word Address Register
NDFC_BLOCK_NUM	0x1C	NDFC Data Block Number Register
NDFC_CNT	0x20	NDFC Data Counter for data transfer Register
NDFC_CMD	0x24	Set up NDFC commands Register
NDFC_RCMD_SET	0x28	Read Command Set Register for vendor's NAND memory
NDFC_WCMD_SET	0x2C	Write Command Set Register for vendor's NAND memory
NDFC_ECC_CTL	0x34	ECC Configure and Control Register
NDFC_ECC_ST	0x38	ECC Status and Operation information Register
NDFC_EFR	0x3C	Enhanced Feature Register
NDFC_ERR_CNT0	0x40	Corrected Error Bit Counter Register 0
NDFC_ERR_CNT1	0x44	Corrected Error Bit Counter Register 1
NDFC_USER_DATA _n	0x50+4*n	User Data Field Register n (n from 0 to 15)
NDFC_EFNAND_STA	0x90	EFNAND Status Register
NDFC_SPARE_AREA	0xA0	Spare Area Configure Register
NDFC_PAT_ID	0xA4	Pattern ID Register
NDFC_RDATA_STA_CTL	0xA8	Read Data Status Control Register
NDFC_RDATA_STA_0	0xAC	Read Data Status Register 0
NDFC_RDATA_STA_1	0xB0	Read Data Status Register 1
NDFC_MDMA_ADDR	0xC0	MBUS DMA Address Register
NDFC_MDMA_CNT	0xC4	MBUS DMA Data Counter Register
NDFC_NDMA_MODE_CTL	0xD0	NDFC Normal DMA Mode Control Register
NDFC_IO_DATA	0x300	Data Input/ Output Port Address Register
RAM0_BASE	0x400	1024 Bytes RAM0 base
RAM1_BASE	0x800	1024 Bytes RAM1 base

4.2.6. NDFC Register Description

4.2.6.1. NDFC Control Register(Default Value: 0x00000000)

Offset: 0x00			Register Name: NDFC_CTL
Bit	R/W	Default/Hex	Description
31:28	/	/	/
27:24	R/W	0	NDFC_CE_SEL Chip Select for 8 NAND Flash Chips 0 -7: NDFC Chip Select Signal 0-7 is selected 8-15: NDFC CS[7:0] not selected. GPIO pins can be used for CS.
23:22	/	/	/

21	R/W	0	<p>NDFC_DDR_RM</p> <p>DDR Repeat data mode</p> <p>0: Lower byte</p> <p>1: Higher byte</p>
20	R/W	0	<p>NDFC_DDR_REN</p> <p>DDR Repeat Enable</p> <p>0: Disable</p> <p>1: Enable</p>
19:18	R/W	0	<p>NF_TYPE</p> <p>NAND Flash Type</p> <p>0x0: Normal SDR NAND</p> <p>0x1: Reserved</p> <p>0x2: ONFI DDR NAND</p> <p>0x3: Toggle DDR NAND</p>
17	R/W	0	<p>NDFC_CLE_POL</p> <p>NDFC Command Latch Enable (CLE) Signal Polarity Select</p> <p>0: High active</p> <p>1: Low active</p>
16	R/W	0	<p>NDFC_ALE_POL</p> <p>NDFC Address Latch Enable (ALE) Signal Polarity Select</p> <p>0: High active</p> <p>1: Low active</p>
15	R/W	0	<p>NDFC_DMA_TYPE</p> <p>0: Dedicated DMA</p> <p>1: Normal DMA</p>
14	R/W	0	<p>NDFC_RAM_METHOD</p> <p>Access internal RAM method</p> <p>0: Access internal RAM by AHB bus</p> <p>1: Access internal RAM by DMA bus</p>
13:12	/	/	/
11:8	R/W	0	<p>NDFC_PAGE_SIZE</p> <p>0x0: 1024 bytes</p> <p>0x1: 2048 bytes</p> <p>0x2: 4096 bytes</p> <p>0x3: 8192 bytes</p> <p>0x4: 16384 bytes</p> <p>Notes: The page size is for main field data.</p>
7	/	/	/
6	R/W	0	<p>NDFC_CE_ACT</p> <p>Chip Select Signal CE# Control During NAND operation</p> <p>0: De-active Chip Select Signal NDFC_CE# during data loading, serial access and other no operation stage for power consumption. NDFC automatic control Chip Select Signals.</p> <p>1: Chip select signal NDFC_CE# is always active after NDFC is enabled</p>

5	/	/	/
4:3	R/W	0	<p>NDFC_RB_SEL NDFC external R/B Signal select The value 0-3 selects the external R/B signal. The same R/B signal can be used for multiple chip select flash.</p>
2	R/W	0	<p>NDFC_BUS_WIDTH 0: 8-bit bus 1: 16-bit bus</p>
1	R/W	0	<p>NDFC_RESET NDFC Reset Write 1 to reset NDFC and clear to 0 after reset</p>
0	R/W	0	<p>NDFC_EN NDFC Enable Control 0: Disable NDFC 1: Enable NDFC</p>

4.2.6.2. NDFC Status Register(Default Value: 0x00000000)

Offset: 0x04			Register Name: NDFC_ST
Bit	R/W	Default/Hex	Description
31:14	/	/	/
13	R	0	<p>NDFC_RDATA_STA_0 0: The number of bit 1 during current read operation is greater threshold value. 1: The number of bit 1 during current read operation is less than or equal to threshold value. This field only is valid when NDFC_RDATA_STA_EN is 1. The threshold value is configured in NDFC_RDATA_STA_TH.</p>
12	R	0	<p>NDFC_RDATA_STA_1 0: The number of bit 0 during current read operation is greater threshold value. 1: The number of bit 0 during current read operation is less than or equal to than threshold value. This field only is valid when NDFC_RDATA_STA_EN is 1. The threshold value is configured in NDFC_RDATA_STA_TH.</p>
11	R	0	<p>NDFC_RB_STATE3 NAND Flash R/B 3 Line State 0: NAND Flash in BUSY State 1: NAND Flash in READY State</p>
10	R	0	<p>NDFC_RB_STATE2 NAND Flash R/B 2 Line State 0: NAND Flash in BUSY State 1: NAND Flash in READY State</p>

9	R	0	<p>NDFC_RB_STATE1</p> <p>NAND Flash R/B 1 Line State</p> <p>0: NAND Flash in BUSY State</p> <p>1: NAND Flash in READY State</p>
8	R	0	<p>NDFC_RB_STATE0</p> <p>NAND Flash R/B 0 Line State</p> <p>0: NAND Flash in BUSY State</p> <p>1: NAND Flash in READY State</p>
7:5	/	/	/
4	R	0	<p>NDFC_STA</p> <p>0: NDFC FSM in IDLE state</p> <p>1: NDFC FSM in BUSY state</p> <p>When NDFC_STA is 0, NDFC can accept new command and process command.</p>
3	R	0	<p>NDFC_CMD_FIFO_STATUS</p> <p>0: Command FIFO not full and can receive new command</p> <p>1: Full and waiting NDFC to process commands in FIFO</p> <p>Since there is only one 32-bit FIFO for command. When NDFC latches one command, command FIFO is free and can accept another new command.</p>
2	R/W	0	<p>NDFC_DMA_INT_FLAG</p> <p>When it is 1, it means that a pending DMA is completed. It will be clear after writing 1 to this bit or it will be automatically clear before FSM processing an new command.</p>
1	R/W	0	<p>NDFC_CMD_INT_FLAG</p> <p>When it is 1, it means that NDFC has finished one Normal Command Mode or one Batch Command Work Mode. It will be clear after writing 1 to this bit or it will be automatically clear before FSM processing a new command.</p>
0	R/W	0	<p>NDFC_RB_B2R</p> <p>When it is 1, it means that NDFC_R/B# signal is transferred from BUSY state to READY state. It will be clear after writing 1 to this bit.</p>

4.2.6.3. NDFC Interrupt and DMA Enable Register(Default Value: 0x00000000)

Offset: 0x08			Register Name: NDFC_INT
Bit	R/W	Default/Hex	Description
31:3	/	/	/
2	R/W	0	<p>NDFC_DMA_INT_ENABLE</p> <p>Enable or disable interrupt when a pending DMA is completed.</p>
1	R/W	0	<p>NDFC_CMD_INT_ENABLE</p> <p>Enable or disable interrupt when NDFC has finished the procession of a single command in Normal Command Work Mode or one Batch</p>

			Command Work Mode. 0: Disable 1: Enable
0	R/W	0	NDFC_B2R_INT_ENABLE Enable or disable interrupt when NDFC_RB# signal is transferring from BUSY state to READY state 0: Disable 1: Enable

4.2.6.4. NDFC Timing Control Register(Default Value: 0x00000000)

Offset: 0x0C			Register Name: NDFC_TIMING_CTL
Bit	R/W	Default/Hex	Description
31:12	/	/	/
11:8	R/W	0	NDFC_READ_PIPE In SDR mode: 0: Normal 1: EDO 2: E-EDO Other : Reserved In DDR mode: 1~15 is valid.(These bits configure the number of clock when data is valid after RE#'s falling edge)
7:6	/	/	/
5:0	R/W	0	NDFC_DC_CTL NDFC Delay Chain Control. (These bits are only valid in DDR data interface, and configure the relative phase between DQS and DQ[0...7])

4.2.6.5. NDFC Timing Configure Register(Default Value: 0x00000095)

Offset: 0x10			Register Name: NDFC_TIMING_CFG
Bit	R/W	Default/Hex	Description
31:20	/	/	/
19:18	R/W	0	T_WC Write Cycle Time 0: 1*2T 1: 2*2T 2: 3*2T 3: 4*2T
17:16	R/W	0	T_CCS Change Column Setup Time

			0: 16*2T 1: 24*2T 2: 32*2T 3: 64*2T
15:14	R/W	0	T_CLHZ CLE High to Output Hi-z 0: 2*2T 1: 8*2T 2: 16*2T 3: 31*2T
13:12	R/W	0	T_CS CE Setup Time 0: 2*2T 1: 8*2T 2: 16*2T 3: 31*2T
11	R/W	0	T_CDQSS DQS Setup Time for data input start 0: 8*2T 1: 24*2T
10:8	R/W	0	T_CAD Command, Address, Data Delay 000: 4*2T 001: 8*2T 010: 12*2T 011: 16*2T 100: 24*2T 101: 32*2T 110/111: 64*2T
7:6	R/W	0x2	T_RHW RE# high to WE# low cycle number 00: 4*2T 01: 8*2T 10: 12*2T 11: 20*2T
5:4	R/W	0x1	T_WHR WE# high to RE# low cycle number 00: 8*2T 01: 16*2T 10: 24*2T 11: 32*2T
3:2	R/W	0x1	T_ADL Address to Data Loading cycle number 00: 0*2T

			01: 8*2T 10: 16*2T 11: 24*2T
1:0	R/W	0x1	T_WB WE# high to busy cycle number 00:14*2T 01:22*2T 10: 30*2T 11:38*2T

4.2.6.6. NDFC Address Low Word Register(Default Value: 0x00000000)

Offset: 0x14			Register Name: NDFC_ADDR_LOW
Bit	R/W	Default/Hex	Description
31:24	R/W	0	ADDR_DATA4 NAND Flash 4th Cycle Address Data
23:16	R/W	0	ADDR_DATA3 NAND Flash 3rd Cycle Address Data
15:8	R/W	0	ADDR_DATA2 NAND Flash 2nd Cycle Address Data
7:0	R/W	0	ADDR_DATA1 NAND Flash 1st Cycle Address Data

4.2.6.7. NDFC Address High Word Register(Default Value: 0x00000000)

Offset: 0x18			Register Name: NDFC_ADDR_HIGH
Bit	R/W	Default/Hex	Description
31:24	R/W	0	ADDR_DATA8 NAND Flash 8th Cycle Address Data
23:16	R/W	0	ADDR_DATA7 NAND Flash 7th Cycle Address Data
15:8	R/W	0	ADDR_DATA6 NAND Flash 6th Cycle Address Data
7:0	R/W	0	ADDR_DATA5 NAND Flash 5th Cycle Address Data

4.2.6.8. NDFC Data Block Number Register(Default Value: 0x00000000)

Offset: 0x1C			Register Name: NDFC_DATA_BLOCK_NUM
Bit	R/W	Default/Hex	Description

31:6	/	/	/
			<p>NDFC_DATA_BLOCK_NUM DATA BLOCK Number It is used for batch command procession. 0: no data 1: 1 data blocks 2: 2 data blocks ... 16: 16 data blocks Others: Reserved</p>
4:0	R/W	0	Notes: 1 data block = 512 or 1024 bytes main field data

4.2.6.9. NDFC Data Counter Register(Default Value: 0x00000000)

Offset: 0x20			Register Name: NDFC_CNT
Bit	R/W	Default/Hex	Description
31:10	/	/	/
			<p>NDFC_DATA_CNT Transfer Data Byte Counter The length can be set from 1 byte to 1024 bytes. However, 1024 bytes is set when it is zero.</p>
9:0	R/W	0	

4.2.6.10. NDFC Command IO Register(Default Value: 0x00000000)

Offset: 0x24			Register Name: NDFC_CMD
Bit	R/W	Default/Hex	Description
			<p>NDFC_CMD_TYPE 00: Common Command for normal operation 01: Special Command for Flash Spare Field Operation 10: Page Command for batch process operation 11: Reserved</p>
31:30	R/W	0	
			<p>NDFC_SEND_FOURTH_CMD 0: Don't send third set command 1: Send it on the external memory's bus Notes: It is used for EF-NAND page read.</p>
29	R/W	0	
			<p>NDFC_SEND_THIRD_CMD 0: Don't send third set command 1: Send it on the external memory's bus Notes: It is used for EF-NAND page read.</p>
28	R/W	0	
			<p>NDFC_ROW_ADDR_AUTO Row Address Auto Increase for Page Command</p>
27	R/W	0	

			<p>0: Normal operation 1: Row address increasing automatically</p>
26	R/W	0	<p>NDFC_DATA_METHOD Data swap method when the internal RAM and system memory It is only active for Common Command and Special Command. 0: No action 1: DMA transfer automatically It only is active when NDFC_RAM_METHOD is 1. If this bit is set to 1, NDFC should setup DRQ to fetching data before output to Flash or NDFC should setup DRQ to sending out to system memory after fetching data from Flash. If this bit is set to 0, NDFC output the data in internal RAM or do nothing after fetching data from Flash.</p>
25	R/W	0	<p>NDFC_SEQ User data & BCH check word position. It only is active for Page Command, don't care about this bit for other two commands 0: Interleave Method (on page spare area) 1: Sequence Method (following data block)</p>
24	R/W	0	<p>NDFC_SEND_SECOND_CMD 0: Don't send second set command 1: Send it on the external memory's bus</p>
23	R/W	0	<p>NDFC_WAIT_FLAG 0: NDFC can transfer data regardless of the internal NDFC_RB wire 1: NDFC can transfer data when the internal NDFC_RB wire is READY; otherwise it can't when the internal NDFC_RB wire is BUSY.</p>
22	R/W	0	<p>NDFC_SEND_FIRST_CMD 0: Don't send first set command 1: Send it on the external memory's bus</p>
21	R/W	0	<p>NDFC_DATA_TRANS 0: No data transfer on external memory bus 1: Data transfer and direction is decided by the field NDFC_ACCESS_DIR</p>
20	R/W	0	<p>NDFC_ACCESS_DIR 0: Read NAND Flash 1: Write NAND Flash</p>
19	R/W	0	<p>NDFC_SEND_ADR 0: Don't send ADDRESS 1: Send N cycles ADDRESS, the number N is specified by NDFC_ADR_NUM field</p>
18:16	R/W	0	<p>NDFC_ADR_NUM Address Cycles' Number 000: 1 cycle address field 001: 2 cycles address field 010: 3 cycles address field 011: 4 cycles address field</p>

			100: 5 cycles address field 101: 6 cycles address field 110: 7 cycles address field 111: 8 cycles address field
15:8	R/W	0	NDFC_CMD_HIGH_BYTE NDFC Command high byte data If 8-bit command is supported, the high byte should be zero for 16-bit bus width NAND Flash. For 8-bit bus width NAND Flash, high byte command is discarded.
7:0	R/W	0	NDFC_CMD_LOW_BYTE NDFC Command low byte data This command will be sent to external Flash by NDFC.

4.2.6.11. NDFC Command Set Register 0(Default Value: 0x00E00530)

Offset: 0x28			Register Name: NDFC_CMD_SET0
Bit	R/W	Default/Hex	Description
31:24	/	/	/
23:16	R/W	0xE0	NDFC_RANDOM_READ_CMD1 Used for Batch Read Operation
15:8	R/W	0x05	NDFC_RANDOM_READ_CMD0 Used for Batch Read Operation
7:0	R/W	0x30	NDFC_READ_CMD Used for Batch Read Operation

4.2.6.12. NDFC Command Set Register 1(Default Value: 0x70008510)

Offset: 0x2C			Register Name: NDFC_CMD_SET1
Bit	R/W	Default/Hex	Description
31:16	R/W	0x70	NDFC_READ_CMD0 Used for EF-NAND Page Read operation
23:16	R/W	0x00	NDFC_READ_CMD1 Used for EF-NAND Page Read operation
15:8	R/W	0x85	NDFC_RANDOM_WRITE_CMD Used for Batch Write Operation
7:0	R/W	0x10	NDFC_PROGRAM_CMD Used for Batch Write Operation

4.2.6.13. NDFC IO Data Register(Default Value: 0x00000000)

Offset: 0x30			Register Name: NDFC_IO_DATA
Bit	R/W	Default/Hex	Description
31:0	R/W	0	NDFC_IO_DATA Read/Write data into internal RAM Access unit is 32-bit.

4.2.6.14. NDFC ECC Control Register(Default Value: 0x4a800008)

Offset: 0x34			Register Name: NDFC_ECC_CTL
Bit	R/W	Default/Hex	Description
31	/	/	/
30:16	R/W	0x4a80	NDFC_RANDOM_SEED The seed value for randomize engine. It is only active when NDFC_RANDOM_EN is set to '1'.
15:12	R/W	0	NDFC_ECC_MODE 0x0: BCH-16 for one ECC Data Block 0x1: BCH-24 for one ECC Data Block 0x2 : BCH-28 for one ECC Data Block 0x3 : BCH-32 for one ECC Data Block 0x4 : BCH-40 for one ECC Data Block 0x5 : BCH-48 for one ECC Data Block 0x6 : BCH-56 for one ECC Data Block 0x7 : BCH-60 for one ECC Data Block 0x8 : BCH-64 for one ECC Data Block Others: Reserved
11	R/W	0	NDFC_RANDOM_SIZE 0: ECC block size 1: Page size
10	R/W	0	NDFC_RANDOM_DIRECTION 0: LSB first 1: MSB first
9	R/W	0	NDFC_RANDOM_EN 0: Disable Data Randomize 1: Enable Data Randomize
8:6	/	/	/
5	R/W	0	NDFC_ECC_BLOCK_SIZE 0: 1024 bytes of one ECC data block 1: 512 bytes of one ECC data block
4	R/W	0	NDFC_ECC_EXCEPTION 0: Normal ECC

			<p>1: For ECC, there is an exception. If all data is 0xff or 0x00 for the block. When reading this page, ECC assumes that it is right. For this case, no error information is reported.</p> <p>Notes: It only is active when ECC is ON</p>
3	R/W	0x1	<p>NDFC_ECC_PIPELINE</p> <p>Pipeline function enable or disable for batch command</p> <p>0: Error Correction function no pipeline with next block operation</p> <p>1: Error Correction pipeline</p>
2:1	/	/	/
0	R/W	0	<p>NDFC_ECC_EN</p> <p>0: ECC is OFF</p> <p>1: ECC is ON</p>

4.2.6.15. NDFC ECC Status Register(Default Value: 0x00000000)

Offset: 0x38			Register Name: NDFC_ECC_ST
Bit	R/W	Default/Hex	Description
31:16	R	0	<p>NDFC_PAT_FOUND</p> <p>Special pattern (all 0x00 or all x0ff) Found Flag for 16 Data Blocks</p> <p>0: No Found</p> <p>1: Special pattern is found</p> <p>When this field is '1', this means that the special data is found for reading external NAND flash. The register of NDFC_PAT_ID would indicate which pattern is found.</p>
15:0	R	0	<p>NDFC_ECC_ERR</p> <p>Error information bit of 16 Data Blocks</p> <p>0: ECC can correct these error bits or there is no error bit</p> <p>1: Error bits number beyond of ECC correction capability and can't correct them</p> <p>Notes: The LSB of this register is corresponding the 1st ECC data block. 1 ECC Data Block = 512 or 1024 bytes.</p>

4.2.6.16. NDFC Enhanced Feature Register(Default Value: 0x00000000)

Offset: 0x3C			Register Name: NDFC_EFR
Bit	R/W	Default/Hex	Description
31:9	R/W	0	/
8	R/W	0	<p>NDFC_WP_CTRL</p> <p>NAND Flash Write Protect Control Bit</p> <p>0: Write Protect is active</p> <p>1: Write Protect is not active</p>

			Notes: When this bit is '0', WP signal line is low level and external NAND flash is on protected state.
7	/	/	/
6:0	R/W	0	<p>NDFC_ECC_DEBUG</p> <p>For the purpose of debugging ECC engine, special bits error are inserted before writing external Flash Memory.</p> <p>0: No error is inserted (ECC Normal Operation)</p> <p>n: N bits error are inserted</p>

4.2.6.17. NDFC Error Counter Register 0(Default Value: 0x00000000)

Offset: 0x40			Register Name: NDFC_ERR_CNT0
Bit	R/W	Default/Hex	Description
[8i+7:8i] (i=0~3)	R	0	<p>ECC_COR_NUM</p> <p>ECC Corrected Bits Number for ECC Data Block[n] (n from 0 to 3)</p> <p>0: No corrected bits</p> <p>1: 1 corrected bit</p> <p>2: 2 corrected bits</p> <p>...</p> <p>64: 64 corrected bits</p> <p>Others: Reserved</p> <p>Notes: 1 ECC Data Block = 512 or 1024 bytes</p>

4.2.6.18. NDFC Error Counter Register 1(Default Value: 0x00000000)

Offset: 0x44			Register Name: NDFC_ERR_CNT1
Bit	R/W	Default/Hex	Description
[8i+7:8i] (i=0~3)	R	0	<p>ECC_COR_NUM</p> <p>ECC Corrected Bits Number for ECC Data Block[n] (n from 4 to 7)</p> <p>0: No corrected bits</p> <p>1: 1 corrected bit</p> <p>2: 2 corrected bits</p> <p>...</p> <p>64: 64 corrected bits</p> <p>Others: Reserved</p> <p>Notes: 1 ECC Data Block = 512 or 1024 bytes</p>

4.2.6.19. NDFC Error Counter Register 2(Default Value: 0x00000000)

Offset: 0x48			Register Name: NDFC_ERR_CNT2
--------------	--	--	-------------------------------------

Bit	R/W	Default/Hex	Description
[8i+7:8i] (i=0~3)	R	0	<p>ECC_COR_NUM ECC Corrected Bits Number for ECC Data Block[n] (n from 8 to 11)</p> <p>0: No corrected bits 1: 1 corrected bit 2: 2 corrected bits ... 64: 64 corrected bits Others: Reserved</p> <p>Notes: 1 ECC Data Block = 512 or 1024 bytes</p>

4.2.6.20. NDFC Error Counter Register 3(Default Value: 0x00000000)

Offset: 0x4C			Register Name: NDFC_ERR_CNT3
Bit	R/W	Default/Hex	Description
[8i+7:8i] (i=0~3)	R	0	<p>ECC_COR_NUM ECC Corrected Bits Number for ECC Data Block[n] (n from 12 to 15)</p> <p>0: No corrected bits 1: 1 corrected bit 2: 2 corrected bits ... 64: 64 corrected bits Others: Reserved</p> <p>Notes: 1 ECC Data Block = 512 or 1024 bytes</p>

4.2.6.21. NDFC User Data Register [n](Default Value: 0xffffffff)

Offset: 0x50 + 0x4*n			Register Name: NDFC_USER_DATA(n=0~15)
Bit	R/W	Default/Hex	Description
31:0	R/W	0xffffffff	<p>USER_DATA User Data for ECC Data Block[n] (n from 0 to 15)</p> <p>Notes: 1 ECC Data Block = 512 or 1024 bytes</p>

4.2.6.22. NDFC EFNAND STATUS Register(Default Value: 0x00000000)

Offset: 0x90			Register Name: NDFC_EFNAND_STATUS
Bit	R/W	Default/Hex	Description
31:8	/	/	/
7:0	R	0	<p>EF_NAND_STATUS The Status Value for EF-NAND Page Read operation</p>

4.2.6.23. NDFC Spare Area Register(Default Value: 0x00000400)

Offset: 0xA0			Register Name: NDFC_SPARE_AREA
Bit	R/W	Default/Hex	Description
31:16	/	/	/
15:0	R/W	0x400	NDFC_SPARE_ADR This value indicates the spare area first byte address for NDFC interleave page operation.

4.2.6.24. NDFC Pattern ID Register(Default Value: 0x00000000)

Offset: 0xA4			Register Name: NDFC_PAT_ID
Bit	R/W	Default/Hex	Description
[2i+1:2i] (i=0~15)	R	0	PAT_ID Special Pattern ID for 16 ECC data block 0: All 0x00 is found 1: All 0xFF is found Others: Reserved

4.2.6.25. NDFC Read Data Status Control Register(Default Value: 0x01000000)

Offset: 0xA8			Register Name: NDFC_RDATA_STA_CTL
Bit	R/W	Default/Hex	Description
31:25	/	/	/
24	R/W	1	NDFC_RDATA_STA_EN 0: Disable to count the number of bit 1 and bit 0 during current read operation; 1: Enable to count the number of bit 1 and bit 0 during current read operation; The number of bit 1 and bit 0 during current read operation can be used to check whether a page is blank or bad.
23:18	/	/	/
17:0	R/W	0	NDFC_RDATA_STA_TH The threshold value to generate data status. If the number of bit 1 during current read operation is less than or equal to threshold value, the bit 13 of NDFC_ST register will be set. If the number of bit 0 during current read operation is less than or equal to threshold value, the bit 12 of NDFC_ST register will be set.

4.2.6.26. NDFC Read Data Status Register 0(Default Value: 0x00000000)

Offset: 0xAC			Register Name: NDFC_RDATA_STA_0
Bit	R/W	Default/Hex	Description
31:0	R	0	BIT_CNT_1 The number of input bit 1 during current command. It will be cleared automatically when next command is executed.

4.2.6.27. NDFC Read Data Status Register 1(Default Value: 0x00000000)

Offset: 0xB0			Register Name: NDFC_RDATA_STA_1
Bit	R/W	Default/Hex	Description
31:0	R	0	BIT_CNT_0 The number of input bit 0 during current command. It will be cleared automatically when next command is executed.

4.2.6.28. NDFC MBUS DMA Address Register(Default Value: 0x00000000)

Offset: 0xC0			Register Name: NDFC_MDMA_ADDR
Bit	R/W	Default/Hex	Description
31:0	R/W	0	MDMA_ADDR MBUS DMA address

4.2.6.29. NDFC MBUS DMA Byte Counter Register(Default Value: 0x00000000)

Offset: 0xC4			Register Name: NDFC_MDMA_CNT
Bit	R/W	Default/Hex	Description
14:0	R/W	0	MDMA_CNT MBUS DMA data counter

4.2.6.30. NDFC Normal DMA Mode Control Register(Default Value: 0x000000A5)

Offset: 0xD0			Register Name: NDFC_NDMA_MODE_CTL
Bit	R/W	Default/Hex	Description
7:0	R/W	0xA5	NDMA_MODE_CTL 0xEA:NDMA handshake mode Note: NDMA wait mode don't care this value. 0xA5 can be used in handshake mode, but 0xEA is better.

4.3. SD-MMC Host Controller

4.3.1. Overview

The SD-MMC Host controller(SMHC) can be configured either as a Secure Digital Multimedia Card controller, which simultaneously supports Secure Digital memory (SD Memory), UHS-1 Card, Secure Digital I/O (SDIO), Multimedia Cards (MMC) and eMMC.

The SMHC controller includes the following features:

- Supports Secure Digital memory protocol commands (up to SD3.0)
- Supports Secure Digital I/O protocol commands(up to SDIO2.0)
- Supports Multimedia Card protocol commands (up to MMC5.0)
- Supports eMMC boot operation
- Supports Command Completion signal and interrupt to host processor and Command Completion Signal disable feature
- Supports one SD (Version1.0 to 3.0) or MMC (Version3.3 to 5.0)
- Supports hardware CRC generation and error detection
- Supports host pull-up control
- Supports SDIO interrupts in 1-bit and 4-bit modes
- Supports block size of 1 to 65535 bytes
- Supports descriptor-based internal DMA controller
- Internal 1024 bytes FIFO for data transfer
- Support 3.3 and 1.8V IO pad

4.3.2. Block Diagram

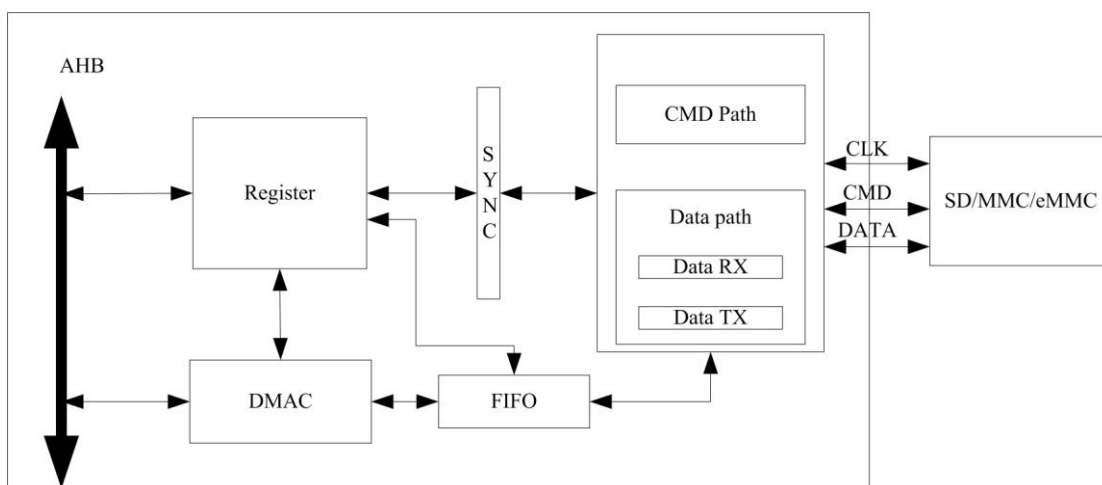

Figure 4-16. SD/MMC Controller Block Diagram

4.3.3. SMHC Controller Timing Diagram

Please refer to relative specifications:

- Physical Layer Specification Ver3.00 Final,2009.04.16
- SDIO Specification Ver2.00
- Multimedia Cards (MMC : version 4.2)
- JEDEC Standard – JESD84-B50, Embedded Multimedia Card (eMMC) Card Product Standard

4.3.4. SMHC Operation Description

4.3.4.1. External Signal List

Port Name	Width	Direction	Description
CLK	1	OUT	Clock signal for SD/SDIO/MMC card.
CMD	1	IN/OUT	CMD line.
DATA	4/8	IN/OUT	Data lines, 4bit for SMHC0 and SMHC1, 8bit for SMHC2.
DS	1	OUT	Data strobe signal for SMHC2.
RST	1	OUT	Reset signal for SMHC2.

Figure 4-17 shows a pin diagram of the SMHC.

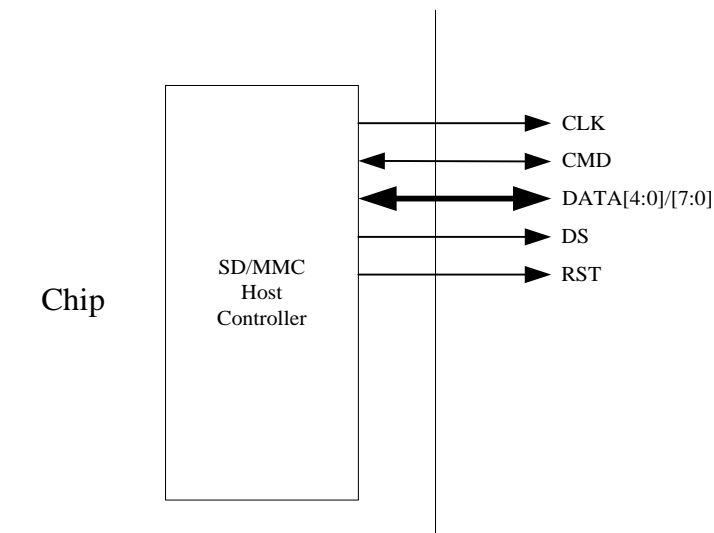

Figure 4-17. SD/MMC Pin Diagram

4.3.4.2. Calibrate Delay Chain

The sample clock delay chain and Data Strobe delay chain(only in SMHC2) are used to generate delay to make proper timing between sample clock/Data Strobe and data signals. Each delay chain is made up with 64 delay cells. The delay time of one delay cell can be estimated through delay chain calibration.

The steps to calibrate delay chain are as follows:

Step1: Enable SMHC. In order to calibrate delay chain by operation registers in SMHC, SMHC must be enabled through **Bus Software Reset Register 0** and **Bus Clock Gating Register0**.

Step2: Configure a proper clock for SMHC. Calibration delay chain is based on the clock for SMHC from Clock Control Unit(**CCU**). Calibration delay chain a internal function in SMHC and don't need device. So, it is unnecessary to open clock signal for device. The recommended clock frequency is 200MHz.

Step3: Set proper initial delay value. Writing 0xA0 to **delay control register** enables **Delay Software Enable (bit[7])** and sets initial delay value 0x20 to **Delay chain(bit[5:0])**. Then write 0x0 to **delay control register** to clear the value.

Step4: Write 0x8000 to **delay control register** to start calibrate delay chain.

Step5: Wait until the flag(Bit14 in **delay control register**) of calibration done is set. The number of delay cells is shown at Bit8~Bit13 in **delay control register**. The delay time generated by these delay cells is equal to the cycle of SMHC's clock nearly. This value is the result of calibration.

Step6: Calculate the delay time of one delay cell according to the cycle of SMHC's clock and the result of calibration.

Note: In the above descriptions,**delay control register** contains **SMHC Sample Delay Control Register** and **SMHC Data Strobe Delay Control Register**.**Delay Software Enable** contains **Sample Delay Software Enable** and **Data Strobe Delay Software Enable**. **Delay chain** contains **Sample Delay Software** and **Data Strobe Delay Software**.

4.3.5. SMHC DMA Controller Description

SMHC controller has an internal DMA controller (IDMAC) to transfer data between host memory and SDMMC port. With a descriptor, IDMAC can efficiently move data from source to destination by automatically loading next DMA transfer arguments, which need less CPU intervention. Before transfer data in IDMAC, host driver should construct a descriptor list, configure arguments of every DMA transfer, then launch the descriptor and start the DMA. IDMAC has an interrupt controller, when enabled, it can interrupt the HOST CPU in situations such as data transmission completed or some errors happened.

4.3.5.1. IDMAC Descriptor Structure

The IDMAC uses a descriptor with a chain structure, and each descriptor points to a unique buffer and the next descriptor.

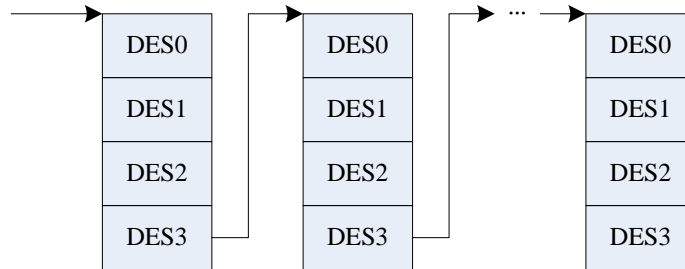

This figure illustrates the internal formats of a descriptor. The descriptor addresses must be aligned to the bus width used for 32-bit buses. Each descriptor contains 16 bytes of control and status information.

DES0 is a notation used to denote the [31:0] bits, **DES1** to denote [63:32] bits, **DES2** to denote [95:64]bits, and **DES3** to denote [127:96]bits in a descriptor.

4.3.5.2. DES0 definition

Bits	Name	Descriptor
31	HOLD	DES_OWN_FLAG When set, this bit indicates that the descriptor is owned by the IDMAC. When this bit is reset, it indicates that the descriptor is owned by the host. This bit is cleared when transfer is over.
30	ERROR	ERR_FLAG When some error happened in transfer, this bit will be set.
29:6	/	/
5	/	Not used
4	Chain Flag	CHAIN_MOD When set, this bit indicates that the second address in descriptor is the next descriptor address. Must be set 1.
3	First DES Flag	FIRST_FLAG When set, this bit indicates that this descriptor contains the first buffer of data. Must be set to 1 in first DES.
2	Last DES Flag	LAST_FLAG When set, this bit indicates that the buffers pointed to by this descriptor are the last data buffer
1	Disable Interrupt on completion	CUR_TXRX_OVER_INT_DIS When set, this bit will prevent the setting of the TX/RX interrupt bit of the IDMAC status register for data that ends in the buffer

		pointed to by this descriptor
0	/	/

4.3.5.3. DES1 definition

Bits	Name	Descriptor
31:16	/	/
15:0	Buffer size	<p>BUFF_SIZE</p> <p>These bits indicate the data buffer byte size, which must be a multiple of 4 bytes. If this field is 0, the DMA ignores this buffer and proceeds to the next descriptor.</p>

4.3.5.4. DES2 definition

Bits	Name	Descriptor
31:0	Buffer address pointer	<p>BUFF_ADDR</p> <p>These bits indicate the physical address of data buffer. The IDMAC ignores DES2[1:0], corresponding to the bus width of 32.</p>

4.3.5.5. DES3 definition

Bits	Name	Descriptor
31:0	Next descriptor address	<p>NEXT_DESP_ADDR</p> <p>These bits indicate the pointer to the physical memory where the next descriptor is present.</p>

4.3.6. SMHC Register List

Module Name	Base Address
SMHC0	0x01C0F000
SMHC1	0x01C10000
SMHC2	0x01C11000

Register Name	Offset	Description
SMHC_CTRL	0x00	Control register
SMHC_CLKDIV	0x04	Clock control register
SMHC_TMOU	0x08	Time out register
SMHC_CTYPE	0x0C	Bus width register

SMHC_BLKSIZE	0x10	Block size register
SMHC_BYTCNT	0x14	Byte count register
SMHC_CMD	0x18	Command register
SMHC_CMDARG	0x1C	Command argument register
SMHC_RESP0	0x20	Response 0 register
SMHC_RESP1	0x24	Response 1 register
SMHC_RESP2	0x28	Response 2 register
SMHC_RESP3	0x2C	Response 3 register
SMHC_INTMASK	0x30	Interrupt mask register
SMHC_MINTSTS	0x34	Masked interrupt status register
SMHC_RINTSTS	0x38	Raw interrupt status register
SMHC_STATUS	0x3C	Status register
SMHC_FIFOTH	0x40	FIFO water level register
SMHC_FUNS	0x44	FIFO function select register
SMHC_TBC0	0x48	Transferred byte count0 between controller and card
SMHC_TBC1	0x4C	Transferred byte count1 between host memory and internal FIFO
SMHC_CSDC	0x54	CRC status detect control register(only for SMHC2)
SMHC_A12A	0x58	Auto command 12 argument register
SMHC_NTSR	0x5C	SD new timing set register(only for SMHC0&1)
SMHC_HWRST	0x78	Hardware reset register
SMHC_DMAL	0x80	DMA control register
SMHC_DLBA	0x84	Descriptor list base address register
SMHC_IDST	0x88	DMAC status register
SMHC_IDIE	0x8C	DMAC interrupt enable register
SMHC_THLD	0x100	Card threshold control register
SMHC_EDSD	0x10C	eMMC4.5 DDR start bit detection control register
SMHC_RES_CRC	0x110	Response CRC from device(only for SMHC0&1)
SMHC_D7_CRC	0x114	CRC in data7 form device(only for SMHC0&1)
SMHC_D6_CRC	0x118	CRC in data6 form device(only for SMHC0&1)
SMHC_D5_CRC	0x11C	CRC in data5 form device(only for SMHC0&1)
SMHC_D4_CRC	0x120	CRC in data4 form device(only for SMHC0&1)
SMHC_D3_CRC	0x124	CRC in data3 form device(only for SMHC0&1)
SMHC_D2_CRC	0x128	CRC in data2 form device(only for SMHC0&1)
SMHC_D1_CRC	0x12C	CRC in data1 form device(only for SMHC0&1)
SMHC_D0_CRC	0x130	CRC in data0 form device(only for SMHC0&1)
SMHC_CRC_STA	0x134	CRC status from device in write operation(only for SMHC0&1)
SMHC_DRV_DL	0x140	Drive delay control register

SMHC_SMAP_DL	0x144	Sample delay control register
SMHC_DS_DL	0x148	Data strobe delay control register
SMHC_FIFO	0x200	Read/ Write FIFO

4.3.7. SMHC Register Description

4.3.7.1. SMHC Global Control Register(Default Value: 0x00000300)

Offset: 0x0000			Register Name: SD_CTRL
Bit	R/W	Default/Hex	Description
31	R/W	0	FIFO_AC_MOD FIFO Access Mode 1: AHB bus 0: DMA bus
30:13	/	/	/
12	R/W	0	TIME_UNIT_CMD Time unit for command line Time unit used to calculate command line time out value defined in RTO_LMT. 0: 1 card clock period 1: 256 card clock period
11	R/W	0	TIME_UNIT_DAT Time unit for data line Time unit used to calculate data line time out value defined in DTO_LMT. 0: 1 card clock period 1: 256 card clock period
10	R/W	0	DDR_MOD_SEL DDR Mode Select Although eMMC's HS400 speed mode is 8-bit DDR, this filed should be cleared when HS_MD_EN is set. 0: SDR mode 1: DDR mode
9	/	/	/
8	R/W	1	CD_DBC_ENB Card Detect (Data[3] status) De-bounce Enable 0: disable de-bounce 1: enable de-bounce
7:6	/	/	/
5	R/W	0	DMA_ENB DMA Global Enable 0: Disable DMA to transfer data, using AHB bus 1: Enable DMA to transfer data

4	R/W	0	INT_ENB Global Interrupt Enable 0: Disable interrupts 1: Enable interrupts
3	/	/	/
2	R/W	0	DMA_RST DMA Reset
1	R/W	0	FIFO_RST FIFO Reset 0: No change 1: Reset FIFO <i>This bit is auto-cleared after completion of reset operation.</i>
0	R/W	0	SOFT_RST Software Reset 0: No change 1: Reset SD/MMC controller <i>This bit is auto-cleared after completion of reset operation.</i>

4.3.7.2. SMHC Clock Control Register(Default Value: 0x00000000)

Offset: 0x0004			Register Name: SD_CLKDIV
Bit	R/W	Default/Hex	Description
31	R/W	0	MASK_DATA0 0 : Do not mask data0 when updata clock ; 1 : Mask data0 when updata clock; Default : 0;
30:18	/	/	/
17	R/W	0	CCLK_CTRL Card Clock Output Control 0 : Card clock always on 1 : Turn off card clock when FSM in IDLE state
16	R/W	0	CCLK_ENB Card Clock Enable 0 : Card Clock off 1 : Card Clock on
15:8	/	/	/
7:0	R/W	0	CCLK_DIV Card clock divider n : Source clock is divided by 2*n.(n=0~255) when HS_MD_EN is set, this field must be cleared.

4.3.7.3. SMHC Timeout Register (Default Value: 0xFFFFF40)

Offset: 0x0008			Register Name: SD_TMOUT
Bit	R/W	Default/Hex	Description
31:8	R/W	0xfffff	DTO_LMT Data Timeout Limit
7:0	R/W	0x40	RTO_LMT Response Timeout Limit

4.3.7.4. SMHC Bus Width Register (Default Value: 0x0000000)

Offset: 0x000c			Register Name: SD_CTYPE
Bit	R/W	Default/Hex	Description
31:2	/	/	/
1:0	R/W	0	CARD_WID Card width 2'b00 : 1-bit width 2'b01 : 4-bit width 2'b1x : 8-bit width

4.3.7.5. SMHC Block Size Register (Default Value: 0x0000200)

Offset: 0x0010			Register Name: SD_BLKSIZE
Bit	R/W	Default/Hex	Description
31:16	/	/	/
15:0	R/W	0x200	BLK_SZ Block size

4.3.7.6. SMHC Block Count Register (Default Value: 0x0000200)

Offset: 0x0014			Register Name: SD_BYTCNT
Bit	R/W	Default/Hex	Description
31:0	R/W	0x200	BYTE_CNT Byte counter Number of bytes to be transferred; should be integer multiple of Block Size(BLK_SZ) for block transfers.

4.3.7.7. SMHC Command Register (Default Value: 0x00000000)

Offset: 0x0018			Register Name: SD_CMD
Bit	R/W	Default/Hex	Description
31	R/W	0	<p>CMD_LOAD Start Command.</p> <p>This bit is auto cleared when current command is sent. If there is no any response error happened, a command complete interrupt bit (CMD_OVER) will be set in SMHC_RINTSTS register. You should not write any other command before this bit is cleared, or when a command busy interrupt bit (CMD_BUSY) will be set in SMHC_RINTSTS register.</p>
30:29	/	/	/
28	R/W	0	<p>VOL_SW Voltage Switch 0: normal command 1: Voltage switch command, set for CMD11 only</p>
27	R/W	0	<p>BOOT_ABT Boot Abort Setting this bit will terminate the boot operation.</p>
26	R/W	0	<p>EXP_BOOT_ACK Expect Boot Acknowledge. When Software sets this bit along in mandatory boot operation, controller expects a boot acknowledge start pattern of 0-1-0 from the selected card.</p>
25:24	R/W	0	<p>BOOT_MOD Boot Mode 2'b00: Normal command 2'b01: Mandatory Boot operation 2'b10: Alternate Boot operation 2'b11: Reserved</p>
23:22	/	/	/
21	R/W	0	<p>PRG_CLK Change Clock 0: Normal command 1: Change Card Clock; when this bit is set, controller will change clock domain and clock output. No command will be sent.</p>
20:16	/	/	/
15	R/W	0	<p>SEND_INIT_SEQ Send Initialization 0: normal command sending 1: Send initialization sequence before sending this command.</p>
14	R/W	0	<p>STOP_ABT_CMD Stop Abort Command</p>

			0: normal command sending 1: send Stop or abort command to stop current data transfer in progress.(CMD12, CMD52 for writing "I/O Abort" in SDIO CCCR)
13	R/W	0	WAIT_PRE_OVER Wait Data Transfer Over 0: Send command at once, do not care of data transferring 1: Wait for data transfer completion before sending current command
12	R/W	0	STOP_CMD_FLAG Send Stop CMD Automatically (CMD12) 0: Do not send stop command at end of data transfer 1: Send stop command automatically at end of data transfer
11	R/W	0	TRANS_MODE Transfer Mode 0: Block data transfer command 1: Stream data transfer command
10	R/W	0	TRANS_DIR Transfer Direction 0: Read operation 1: Write operation
9	R/W	0	DATA_TRANS Data Transfer 0: without data transfer 1: with data transfer
8	R/W	0	CHK_RESP_CRC Check Response CRC 0: Do not check response CRC 1: Check response CRC
7	R/W	0	LONG_RESP Response Type 0: Short Response (48 bits) 1: Long Response (136 bits)
6	R/W	0	RESP_RCV Response Receive 0: Command without Response 1: Command with Response
5:0	R/W	0	CMD_IDX CMD Index Command index value

4.3.7.8. SMHC Command Argument Register (Default Value: 0x00000000)

Offset: 0x001c			Register Name: SD_CMDARG
Bit	R/W	Default/Hex	Description

31:0	R/W	0	CMD_ARG Command argument
------	-----	---	-----------------------------

4.3.7.9. SMHC Response 0 Register (Default Value: 0x00000000)

Offset: 0x0020			Register Name: SD_RESP0
Bit	R/W	Default/Hex	Description
31:0	R	0	CMD_RESP0 response 0 Bit[31:0] of response

4.3.7.10. SMHC Response 1 Register (Default Value: 0x00000000)

Offset: 0x0024			Register Name: SD_RESP1
Bit	R/W	Default/Hex	Description
31:0	R	0	CMD_RESP1 response 1 Bit[63:31] of response

4.3.7.11. SMHC Response 2 Register (Default Value: 0x00000000)

Offset: 0x0028			Register Name: SD_RESP2
Bit	R/W	Default/Hex	Description
31:0	R	0	CMD_RESP2 response 2 Bit[95:64] of response

4.3.7.12. SMHC Response 3 Register (Default Value: 0x00000000)

Offset: 0x002C			Register Name: SD_RESP3
Bit	R/W	Default/Hex	Description
31:0	R	0	CMD_RESP3 response 3 Bit[127:96] of response

4.3.7.13. SMHC Interrupt Mask Register (Default Value: 0x00000000)

Offset: 0x0030			Register Name: SMHC_INTMASK
Bit	R/W	Default/Hex	Description
31	R/W	0	CARD_REMOVAL_INT_EN Card Removed Interrupt Enable
30	R/W	0	CARD_INSERT_INT_EN Card Inserted Interrupt Enable
29:17	/	/	/
16	R/W	0	SDIO_INT_EN SDIO Interrupt Enable
15	R/W	0	DEE_INT_EN Data End-bit Error Interrupt Enable
14	R/W	0	ACD_INT_EN Auto Command Done Interrupt Enable
13	R/W	0	DSE_BC_INT_EN Data Start Error Interrupt Enable
12	R/W	0	CB_IW_INT_EN Command Busy and Illegal Write Interrupt Enable
11	R/W	0	FU_FO_INT_EN FIFO Underrun/Overflow Interrupt Enable
10	R/W	0	DSTO_VSD_INT_EN Data Starvation Timeout/V1.8 Switch Done Interrupt Enable
9	R/W	0	DTO_BDS_INT_EN Data Timeout/Boot Data Start Interrupt Enable
8	R/W	0	RTO_BACK_INT_EN Response Timeout/Boot ACK Received Interrupt Enable
7	R/W	0	DCE_INT_EN Data CRC Error Interrupt Enable
6	R/W	0	RCE_INT_EN Response CRC Error Interrupt Enable
5	R/W	0	DRR_INT_EN Data Receive Request Interrupt Enable
4	R/W	0	DTR_INT_EN Data Transmit Request Interrupt Enable
3	R/W	0	DTC_INT_EN Data Transfer Complete Interrupt Enable
2	R/W	0	CC_INT_EN Command Complete Interrupt Enable
1	R/W	0	RE_INT_EN Response Error Interrupt Enable
0	/	/	/

4.3.7.14. SMHC Masked Interrupt Status Register (Default Value: 0x00000000)

Offset: 0x0034			Register Name: SMHC_MINTSTS
Bit	R/W	Default/Hex	Description
31	R/W	0	M_CARD_REMOVAL_INT Card Removed
30	R/W	0	M_CARD_INSERT Card Inserted
29:17	/	/	/
16	R/W	0	M_SDIO_INT SDIO Interrupt
15	R/W	0	M_DEE_INT Data End-bit Error When set during receiving data, it means that host controller does not receive valid data end bit. When set during transmitting data, it means that host controller does not receive CRC status taken or received CRC status taken is negative.
14	R/W	0	M_ACD_INT Auto Command Done When set, it means auto stop command(CMD12) completed.
13	R/W	0	M_DSE_BC_INT Data Start Error When set during receiving data, it means that host controller found a error start bit. When set during transmitting data, it means that busy signal is cleared.
12	R/W	0	M_CB_IW_INT Command Busy and Illegal Write
11	R/W	0	M_FU_FO_INT FIFO Underrun/Overflow
10	R/W	0	M_DSTO_VSD_INT Data Starvation Timeout/V1.8 Switch Done
9	R/W	0	M.DTO_BDS_INT Data Timeout/Boot Data Start
8	R/W	0	M_RTO_BACK_INT Response Timeout/Boot ACK Received
7	R/W	0	M_DCE_INT Data CRC Error When set during receiving data, it means that the received data have data CRC error. When set during transmitting data, it means that the received CRC status taken is negative.
6	R/W	0	M_RCE_INT Response CRC Error

5	R/W	0	M_DRR_INT Data Receive Request When set, it means that there are enough data in FIFO during receiving data.
4	R/W	0	M_DTR_INT Data Transmit Request When set, it means that there are enough space in FIFO during transmitting data.
3	R/W	0	M_DTC_INT Data Transfer Complete
2	R/W	0	M_CC_INT Command Complete
1	R/W	0	M_RE_INT Response Error (no response or response CRC error) When set, Transmit Bit error or End Bit error or CMD Index error may occurs.
0	/	/	/

4.3.7.15. SMHC Raw Interrupt Status Register (Default Value: 0x00000000)

Offset: 0x0038			Register Name: SMHC_RINTSTS
Bit	R/W	Default/Hex	Description
31	R/W	0	CARD_REMOVAL Card Removed <i>This is write-1-to-clear bits.</i>
30	R/W	0	CARD_INSERT Card Inserted <i>This is write-1-to-clear bits.</i>
29:17	/	/	/
16	R/W	0	SDIOI_INT SDIO Interrupt <i>This is write-1-to-clear bits.</i>
15	R/W	0	DEE Data End-bit Error When set during receiving data, it means that host controller does not receive valid data end bit. When set during transmitting data, it means that host controller does not receive CRC status taken. <i>This is write-1-to-clear bits.</i>
14	R/W	0	ACD Auto Command Done When set, it means auto stop command(CMD12) completed. <i>This is write-1-to-clear bits.</i>

13	R/W	0	<p>DSE_BC Data Start Error</p> <p>When set during receiving data, it means that host controller found a error start bit.</p> <p>When set during transmitting data, it means that busy signal is cleared.</p> <p><i>This is write-1-to-clear bits.</i></p>
12	R/W	0	<p>CB_IW Command Busy and Illegal Write</p> <p><i>This is write-1-to-clear bits.</i></p>
11	R/W	0	<p>FU_FO FIFO Underrun/Overflow</p> <p><i>This is write-1-to-clear bits.</i></p>
10	R/W	0	<p>DSTO_VSD Data Starvation Timeout/V1.8 Switch Done</p> <p><i>This is write-1-to-clear bits.</i></p>
9	R/W	0	<p>DTO_BDS Data Timeout/Boot Data Start</p> <p><i>This is write-1-to-clear bits.</i></p>
8	R/W	0	<p>RTO_BACK Response Timeout/Boot ACK Received</p> <p><i>This is write-1-to-clear bits.</i></p>
7	R/W	0	<p>DCE Data CRC Error</p> <p>When set during receiving data, it means that the received data have data CRC error.</p> <p>When set during transmitting data, it means that the received CRC status taken is negative.</p> <p><i>This is write-1-to-clear bits.</i></p>
6	R/W	0	<p>RCE Response CRC Error</p> <p><i>This is write-1-to-clear bits.</i></p>
5	R/W	0	<p>DRR Data Receive Request</p> <p>When set, it means that there are enough data in FIFO during receiving data.</p> <p><i>This is write-1-to-clear bits.</i></p>
4	R/W	0	<p>DTR Data Transmit Request</p> <p>When set, it means that there are enough space in FIFO during transmitting data.</p> <p><i>This is write-1-to-clear bits.</i></p>
3	R/W	0	<p>DTC Data Transfer Complete</p> <p><i>This is write-1-to-clear bits.</i></p>

2	R/W	0	CC Command Complete <i>This is write-1-to-clear bits.</i>
1	R/W	0	RE Response Error (no response or response CRC error) When set, Transmit Bit error or End Bit error or CMD Index error may occurs. <i>This is write-1-to-clear bits.</i>
0	/	/	/

4.3.7.16. SMHC Status Register (Default Value: 0x00000006)

Offset: 0x003C			Register Name: SMHC_STATUS
Bit	R/W	Default/Hex	Description
31	R	0	DMA_REQ DMA Request DMA request signal state
30:26	/	/	/
25:17	R	0	FIFO_LEVEL FIFO Level Number of filled locations in FIFO
16:11	R	0	RESP_IDX Response Index Index of previous response, including any auto-stop sent by controller
10	R	0	FSM_BUSY Data FSM Busy Data transmit or receive state-machine is busy
9	R	0	CARD_BUSY Card data busy Inverted version of DATA[0] 0: card data not busy 1: card data busy
8	R	0	CARD_PRESENT Data[3] status level of DATA[3]; checks whether card is present 0: card not present 1: card present
7:4	R	0	FSM_STA Command FSM states: 0: Idle 1: Send init sequence 2: TX CMD start bit 3: TX CMD TX bit

			4: TX CMD index + argument 5: TX CMD CRC7 6: TX CMD end bit 7: RX response start bit 8: RX response IRQ response 9: RX response TX bit 10: RX response CMD index 11: RX response data 12: RX response CRC7 13: RX response end bit 14: CMD path wait NCC 15: Wait; CMD-to-response turnaround
3	R	0	FIFO_FULL FIFO full 1: FIFO full 0: FIFO not full
2	R	1	FIFO_EMPTY FIFO Empty 1 - FIFO Empty 0 - FIFO not Empty
1	R	1	FIFO_TX_LEVEL FIFO TX Water Level flag 0: FIFO didn't reach transmit trigger level 1: FIFO reached transmit trigger level
0	R	0	FIFO_RX_LEVEL FIFO RX Water Level flag 0: FIFO didn't reach receive trigger level 1: FIFO reached receive trigger level

4.3.7.17. SMHC FIFO Water Level Register (Default Value: 0x000F0000)

Offset: 0x0040			Register Name: SMHC_FIFOTH
Bit	R/W	Default/Hex	Description
31	/	/	/
30:28	R/W	0	BSIZE_OF_TRANS Burst size of multiple transaction 3'b000: 1 transfers 3'b001: 4 3'b010: 8 3'b011: 16 (<i>SMHCO don't support</i>) Others: Reserved Should be programmed same as DMA controller multiple transaction size. The units for transfers are the DWORD. A single transfer would be

			<p>signaled based on this value. Value should be sub-multiple of (RX_TL + 1) and (FIFO_DEPTH - TX_TL)</p> <p>Recommended: MSize = 16, TX_TL = 240, RX_TL = 15(for SMHC1 and SMHC2) MSize = 8, TX_TL = 248, RX_TL = 7(for SMHC0)</p>
27:24	R	0	/
23:16	R/W	0xF	<p>RX_TL RX Trigger Level 0x0~0xFE: RX Trigger Level is 0~254 0xFF reserved</p> <p>FIFO threshold when FIFO request host to receive data from FIFO. When FIFO data level is greater than this value, DMA is request is raised if DMA enabled, or RX interrupt bit is set if interrupt enabled. At the end of packet, if the last transfer is less than this level, the value is ignored and relative request will be raised as usual.</p> <p>Recommended: 15 (means greater than 15, for SMHC1 and SMHC2) 7 (means greater than 7, for SMHC0)</p>
15:8	R	0	/
7:0	R/W	0	<p>TX_TL TX Trigger Level 0x1~0xFF: TX Trigger Level is 1~255 0x0: no trigger</p> <p>FIFO threshold when FIFO requests host to transmit data to FIFO. When FIFO data level is less than or equal to this value, DMA TX request is raised if DMA enabled, or TX request interrupt bit is set if interrupt enabled. At the end of packet, if the last transfer is less than this level, the value is ignored and relative request will be raised as usual.</p> <p>Recommended: 240(means less than or equal to 240, for SMHC1 and SMHC2) 248(means less than or equal to 248,for SMHC0)</p>

4.3.7.18. SMHC Function Select Register (Default Value: 0x00000000)

Offset: 0x0044			Register Name: SMHC_CTRL
Bit	R/W	Default/Hex	Description
31:3	/	/	/
2	R/W	0	<p>ABT_RDATA Abort Read Data 0: Ignored 1: After suspend command is issued during read-transfer, software polls card to find when suspend happened. Once suspend occurs, software sets bit to reset data state-machine, which is waiting for next block of data.</p>

			Used in SDIO card suspends sequence. <i>This bit is auto-cleared once controller reset to idle state.</i>
1	R/W	0	READ_WAIT Read Wait 0: Clear SDIO read wait 1: Assert SDIO read wait
0	R/W	0	HOST_SEND_MMC_IRQRESQ Host Send MMC IRQ Response 0: Ignored 1: Send auto IRQ response When host is waiting MMC card interrupt response, setting this bit will make controller cancel wait state and return to idle state, at which time, controller will receive IRQ response sent by itself. <i>This bit is auto-cleared after response is sent.</i>

4.3.7.19. SMHC Transferred Byte Count Register0 (Default Value: 0x00000000)

Offset: 0x0048			Register Name: SMHC_TBC0
Bit	R/W	Default/Hex	Description
31:0	R	0	TBC0 Transferred Count 0 Number of bytes transferred between card and internal FIFO. The register should be accessed in full to avoid read-coherency problems and read only after data transfer completes.

4.3.7.20. SMHC Transferred Byte Count Register1 (Default Value: 0x00000000)

Offset: 0x004C			Register Name: SMHC_TBC1
Bit	R/W	Default/Hex	Description
31:0	R	0	TBC1 Transferred Count 1 Number of bytes transferred between Host/DMA memory and internal FIFO. The register should be accessed in full to avoid read-coherency problems and read only after data transfer completes.

4.3.7.21. SMHC CRC Status Detect Control Register (Default Value: 0x00000003)

Offset: 0x0054			Register Name: SMHC_CSDC
Bit	R/W	Default/Hex	Description

31:4	/	/	/
3:0	R/W	0x3	CRC_DET_PARA 0x6:HS400 speed mode 0x3:Other speed mode

Note: The register is for SMHC2 only.

4.3.7.22. SMHC Auto Command 12 Register (Default Value: 0x0000ffff)

Offset: 0x0058			Register Name: SMHC_A12A
Bit	R/W	Default/Hex	Description
31:16	/	/	/
0:15	R/W	0xffff	SD_A12A. SD_A12A set the argument of command 12 automatically send by controller

4.3.7.23. SMHC NewTiming Set Register (Default Value: 0x00000000)

Offset: 0x005C			Register Name: SMHC_NTSR_REG
Bit	R/W	Default/Hex	Description
31	R/W	0	MODE_SELEC 0: Old mode of Sample/Output Timing ; 1: New mode of Sample/Output Timing; Default value : 0;
30:6	/	/	/
5:4	R/W	0x00	SAMPLE_TIMING_PHASE(RX) 00: Sample timing phase offset 90° ; 01: Sample timing phase offset 180° ; 10: Sample timing phase offset 270° ; 11: Ignore; Default value: 00;
3:0	/	/	/

Note: The register is for SMHC0 and SMHC1 only.

4.3.7.24. SMHC Hardware Reset Register (Default Value: 0x00000001)

Offset: 0x0078			Register Name: SMHC_HWRST
Bit	R/W	Default/Hex	Description
31:1	/	/	/
0	R/W	1	HW_RESET. 1 : Active mode

			<p>0 : Reset</p> <p>These bits cause the cards to enter pre-idle state, which requires them to be re-initialized.</p>
--	--	--	---

4.3.7.25. SMHC DMAC Control Register (Default Value: 0x00000000)

Offset: 0x0080			Register Name: SMHC_BUS_MODE
Bit	R/W	Default/Hex	Description
31	W	0	<p>DES_LOAD_CTRL</p> <p>When DMAC fetches a descriptor, if the valid bit of a descriptor is not set, DMAC FSM will go to the suspend state. Setting this bit will make DMAC re-fetch descriptor again and do the transfer normally.</p>
30:11	/	/	/
10:8	R	0	/
7	R/W	0	<p>IDMAC_ENB</p> <p>IDMAC Enable.</p> <p>When set, the IDMAC is enabled. DE is read/write.</p>
6:2	R/W	0	/
1	R/W	0	<p>FIX_BUST_CTRL</p> <p>Fixed Burst.</p> <p>Controls whether the AHB Master interface performs fixed burst transfers or not. When set, the AHB will use only SINGLE, INCR4, INCR8 during start of normal burst transfers. When reset, the AHB will use SINGLE and INCR burst transfer operations.</p>
0	R/W	0	<p>IDMAC_RST</p> <p>DMA Reset.</p> <p>When set, the DMA Controller resets all its internal registers. SWR is read/write. It is automatically cleared after 1 clock cycle.</p>

4.3.7.26. SMHC Descriptor List Base Address Register (Default Value: 0x00000000)

Offset: 0x0084			Register Name: SMHC_DLBA_REG
Bit	R/W	Default/Hex	Description
31:0	R/W	0	<p>DES_BASE_ADDR</p> <p>Start of Descriptor List.</p> <p>Contains the base address of the First Descriptor. The LSB bits [1:0] are ignored and taken as all-zero by the IDMAC internally. Hence these LSB bits are read-only.</p>

4.3.7.27. SMHC DMAC Status Register (Default Value: 0x0000_0000)

Offset: 0x0088			Register Name: SMHC_IDST
Bit	R/W	Default/Hex	Description
31:17	/	/	/
16:13	R	0	/
12:10	R	0	<p>DMAC_ERR_STA Error Bits. Indicates the type of error that caused a Bus Error. Valid only with Fatal Bus Error Interrupt (SMHC_IDST[2]) set. This field does not generate an interrupt.</p> <p>3'b001: Host Abort received during transmission 3'b010: Host Abort received during reception Others: Reserved EB is read-only.</p>
9	R/W	0	<p>ABN_INT_SUM Abnormal Interrupt Summary. Logical OR of the following: SMHC_IDST[2]: Fatal Bus Interrupt SMHC_IDST[4]: DU bit Interrupt SMHC_IDST[5]: Card Error Summary Interrupt Only unmasked bits affect this bit. This is a sticky bit and must be cleared each time a corresponding bit that causes AIS to be set is cleared. Writing a 1 clears this bit.</p>
8	R/W	0	<p>NOR_INT_SUM Normal Interrupt Summary. Logical OR of the following: SMHC_IDST[0]: Transmit Interrupt SMHC_IDST[1]: Receive Interrupt Only unmasked bits affect this bit. This is a sticky bit and must be cleared each time a corresponding bit that causes NIS to be set is cleared. Writing a 1 clears this bit.</p>
7:6	/	/	/
5	R/W	0	<p>ERR_FLAG_SUM Card Error Summary. Indicates the status of the transaction to/from the card; also present in RINTSTS. Indicates the logical OR of the following bits: EBE: End Bit Error RTO: Response Timeout/Boot ACK Timeout RCRC: Response CRC SBE: Start Bit Error DRTO: Data Read Timeout/BDS timeout DCRC: Data CRC for Receive RE: Response Error Writing a 1 clears this bit.</p>

4	R/W	0	DES_UNAVL_INT Descriptor Unavailable Interrupt. This bit is set when the descriptor is unavailable due to OWN bit = 0 (DES0[31] =0). Writing a 1 clears this bit.
3	/	/	/
2	R/W	0	FATAL_BERR_INT Fatal Bus Error Interrupt. Indicates that a Bus Error occurred (SMHC_IDST[12:10]). When this bit is set, the DMA disables all its bus accesses. Writing a 1 clears this bit.
1	R/W	0	RX_INT Receive Interrupt. Indicates the completion of data reception for a descriptor. Writing a 1 clears this bit.
0	R/W	0	TX_INT Transmit Interrupt. Indicates that data transmission is finished for a descriptor. Writing a '1' clears this bit.

4.3.7.28. SMHC DMAC Interrupt Enable Register (Default Value: 0x00000000)

Offset: 0x008C			Register Name: SD_IDIE_REG
Bit	R/W	Default/Hex	Description
31:10	/	/	/
9	R/W	0	/
8	R/W	0	/
7:6	/	/	/
5	R/W	0	ERR_SUM_INT_ENB Card Error summary Interrupt Enable. When set, it enables the Card Interrupt summary.
4	R/W	0	DES_UNAVL_INT_ENB Descriptor Unavailable Interrupt. When set along with Abnormal Interrupt Summary Enable, the DU interrupt is enabled.
3	/	/	/
2	R/W	0	FERR_INT_ENB Fatal Bus Error Enable. When set with Abnormal Interrupt Summary Enable, the Fatal Bus Error Interrupt is enabled. When reset, Fatal Bus Error Enable Interrupt is disabled.
1	R/W	0	RX_INT_ENB Receive Interrupt Enable. When set with Normal Interrupt Summary Enable, Receive Interrupt is

			enabled. When reset, Receive Interrupt is disabled.
0	R/W	0	TX_INT_ENB Transmit Interrupt Enable. When set with Normal Interrupt Summary Enable, Transmit Interrupt is enabled. When reset, Transmit Interrupt is disabled.

4.3.7.29. SMHC Card Threshold Control Register (Default Value: 0x00000000)

Offset: 0x0100			Register Name: SMHC_THLD_REG
Bit	R/W	Default/Hex	Description
31:28	/	/	/
27:16	R/W	0	CARD_RD_THLD Card Read Threshold Size
15:3	/	/	/
2	R/W	0	CARD_WR_THLD_ENB(for SMHC2 only) Card Write Threshold Enable(HS400) 0: Card write threshold disable 1: Card write threshold enabled Host controller initiates write transfer only if card threshold amount of data is available in transmit FIFO.
1	R/W	0	BCIG(for SMHC2 only) Busy Clear Interrupt Generation 0: Busy Clear Interrupt disabled 1: Busy Clear Interrupt Enabled The application can disable this feature if it does not want to wait for a Busy Clear Interrupt.
0	R/W	0	CARD_RD_THLD_ENB Card Read Threshold Enable 0 : Card Read Threshold Disable 1 : Card Read Threshold Enable Host controller initiates Read Transfer only if CARD_RD_THLD amount of space is available in receive FIFO.

4.3.7.30. SMHC eMMC4.5 DDR Start Bit Detection Control Register (Default Value: 0x00000000)

Offset: 0x010C			Register Name: EMMC_DDR_SBIT_DET_REG
Bit	R/W	Default/Hex	Description
31	R/W	0	HS_MD_EN HS400 Mode Enable 0:Disable

			1:Enable It is required to set this bit to '1' before initiating any data transfer CMD in HS400 mode.
30:1	/	/	/
0	R/W	0	HALF_START_BIT Control for start bit detection mechanism inside mstorage based on duration of start bit. For eMMC 4.5, start bit can be: 0 : Full cycle 1 : Less than one full cycle Set HALF_START_BIT=1 for eMMC 4.5 and above; set to 0 for SD applications.

4.3.7.31. SMHC Response CRC Register (Default Value: 0x00000000)

Offset: 0x0110			Register Name: RESP_CRC_REG
Bit	R/W	Default/Hex	Description
31:7	/	/	/
6:0	R	0	RESP_CRC Response CRC Response CRC from device.

Note: The register is for SMHC0 and SMHC1 only.

4.3.7.32. SMHC Data7 CRC Register (Default Value: 0x00000000)

Offset: 0x0114			Register Name: DATA7_CRC_REG
Bit	R/W	Default/Hex	Description
31:0	R	0	DAT7_CRC Data[7] CRC CRC in data[7] form device. In 8bit DDR mode, the higher 16 bits indicate the CRC of even data, and the lower 16 bits indicate the CRC of odd data. In 4 bit DDR mode,it is not used. In SDR mode, the higher 16 bits indicate the CRC of all data.

Note: The register is for SMHC0 and SMHC1 only.

4.3.7.33. SMHC Data6 CRC Register (Default Value: 0x00000000)

Offset: 0x0118			Register Name: DATA6_CRC_REG
Bit	R/W	Default/Hex	Description

31:0	R	0	<p>DAT6_CRC Data[6] CRC CRC in data[6] form device. In 8bit DDR mode, the higher 16 bits indicate the CRC of even data, and the lower 16 bits indicate the CRC of odd data. In 4 bit DDR mode,it is not used. In SDR mode, the higher 16 bits indicate the CRC of all data.</p>
------	---	---	---

Note: The register is for SMHC0 and SMHC1 only.

4.3.7.34. SMHC Data5 CRC Register (Default Value: 0x00000000)

Offset: 0x011c			Register Name: DATA5_CRC_REG
Bit	R/W	Default/Hex	Description
31:0	R	0	<p>DAT5_CRC Data[5] CRC CRC in data[5] form device. In 8bit DDR mode, the higher 16 bits indicate the CRC of even data, and the lower 16 bits indicate the CRC of odd data. In 4 bit DDR mode,it is not used. In SDR mode, the higher 16 bits indicate the CRC of all data.</p>

Note: The register is for SMHC0 and SMHC1 only.

4.3.7.35. SMHC Data4 CRC Register (Default Value: 0x00000000)

Offset: 0x0120			Register Name: DATA4_CRC_REG
Bit	R/W	Default/Hex	Description
31:0	R	0	<p>DAT4_CRC Data[4] CRC CRC in data[4] form device. In 8 bit DDR mode, the higher 16 bits indicate the CRC of even data, and the lower 16 bits indicate the CRC of odd data. In 4 bit DDR mode, the higher 16 bits indicate the CRC of odd data, and the lower 16 bits indicate the CRC of even data. In SDR mode, the higher 16 bits indicate the CRC of all data.</p>

Note: The register is for SMHC0 and SMHC1 only.

4.3.7.36. SMHC Data3 CRC Register (Default Value: 0x00000000)

Offset: 0x0124			Register Name: DATA3_CRC_REG
Bit	R/W	Default/Hex	Description

31:0	R	0	<p>DATA3_CRC Data[3] CRC CRC in data[3] from card/eMMC.</p> <p>In 8bit DDR mode,the higher 16 bits indicate the CRC of even data,and the lower 16bits indicate the CRC of odd data.</p> <p>In 4 bit DDR mode,the higher of 16 bits indicate the CRC of odd data ,and the lower 16bits indicate the CRC of even data.</p> <p>In SDR mode,the higher of 16 bits indicate the CRC of all data.</p>
------	---	---	---

Note: The register is for SMHC0 and SMHC1 only.

4.3.7.37. SMHC Data2 CRC Register (Default Value: 0x00000000)

Offset: 0x0128			Register Name: DATA2_CRC_REG
Bit	R/W	Default/Hex	Description
31:0	R	0	<p>DATA2_CRC Data[2] CRC CRC in data[2] from card/eMMC.</p> <p>In 8bit DDR mode,the higher 16 bits indicate the CRC of even data,and the lower 16bits indicate the CRC of odd data.</p> <p>In 4 bit DDR mode,the higher of 16 bits indicate the CRC of odd data ,and the lower 16bits indicate the CRC of even data.</p> <p>In SDR mode,the higher of 16 bits indicate the CRC of all data.</p>

Note: The register is for SMHC0 and SMHC1 only.

4.3.7.38. SMHC Data1 CRC Register (Default Value: 0x00000000)

Offset: 0x012c			Register Name: DATA1_CRC_REG
Bit	R/W	Default/Hex	Description
31:0	R	0	<p>DATA1_CRC Data[1] CRC CRC in data[1] from card/eMMC.</p> <p>In 8bit DDR mode,the higher 16 bits indicate the CRC of even data,and the lower 16bits indicate the CRC of odd data.</p> <p>In 4 bit DDR mode,the higher of 16 bits indicate the CRC of odd data ,and the lower 16bits indicate the CRC of even data.</p> <p>In SDR mode,the higher of 16 bits indicate the CRC of all data.</p>

Note: The register is for SMHC0 and SMHC1 only.

4.3.7.39. SMHC Data0 CRC Register (Default Value: 0x00000000)

Offset: 0x0130			Register Name: DATA0_CRC_REG
----------------	--	--	-------------------------------------

Bit	R/W	Default/Hex	Description
31:0	R	0	<p>DATA0_CRC Data[0] CRC CRC in data[0] from card/eMMC.</p> <p>In 8bit DDR mode,the higher 16 bits indicate the CRC of even data,and the lower 16bits indicate the CRC of odd data.</p> <p>In 4 bit DDR mode,the higher of 16 bits indicate the CRC of odd data, ,and the lower 16bits indicate the CRC of even data.</p> <p>In SDR mode,the higher of 16 bits indicate the CRC of all data.</p>

Note: The register is for SMHC0 and SMHC1 only.

4.3.7.40. SMHC CRC Status Register (Default Value: 0x00000000)

Offset: 0x0134			Register Name: CRC_STA_REG
Bit	R/W	Default/Hex	Description
31:3	/	/	/
2:0	R	0	<p>CRC_STA CRC Status CRC status from card/eMMC in write operation Positive CRC status token:3'b010 Negative CRC status token:3'b101</p>

Note: The register is for SMHC0 and SMHC1 only.

4.3.7.41. SMHC Drive Delay Control Register (Default Value: 0x00000000)

Offset: 0x0140			Register Name: SMHC_DDC_REG
Bit	R/W	Default/Hex	Description
31:18	/	/	/
17	R/W	0	<p>DAT_DRV_PH_SEL Data Drive Phase Select 0: Drive phase offset is 90⁰ 1: Drive phase select is 180⁰ In DDR mode, only 90⁰ phase offset is valid.</p>
16	R/W	1	<p>CMD_DRV_PH_SEL Command Drive Phase Select 0: Drive phase offset is 90⁰ 1: Drive phase select is 180⁰</p>
15:0	/	/	/

4.3.7.42. SMHC Sample Delay Control Register (Default Value: 0x00002000)

Offset: 0x0144			Register Name: SMHC_SAMP_DL_REG
Bit	R/W	Default/Hex	Description
31:16	/	/	/
15	R/W	0	SAMP_DL_CAL_START Sample Delay Calibration Start When set, start sample delay chain calibration.
14	R	0	SAMP_DL_CAL_DONE Sample Delay Calibration Done When set, it means that sample delay chain calibration is done and the result of calibration is shown in SAMP_DL .
13:8	R	0x20	SAMP_DL Sample Delay It indicates the number of delay cells corresponding to current card clock. The delay time generated by these delay cells is equal to the cycle of card clock nearly. Generally, it is necessary to do drive delay calibration when card clock is changed. This bit is valid only when SAMP_DL_CAL_DONE is set.
7	R/W	0	SAMP_DL_SW_EN Sample Delay Software Enable When set, enable sample delay specified at SAMP_DL_SW .
6	/	/	/
5:0	R/W	0	SAMP_DL_SW Sample Delay Software The relative delay between clock line and command line, data lines. It can be determined according to the value of SAMP_DL , the cycle of card clock and device's input timing requirement.

4.3.7.43. SMHC Data Strobe Delay Control Register (Default Value: 0x00002000)

Offset: 0x0148			Register Name: SMHC_DS_DL_REG
Bit	R/W	Default/Hex	Description
31:16	/	/	/
15	R/W	0	DS_DL_CAL_START Data Strobe Delay Calibration Start When set, start sample delay chain calibration.
14	R	0	DS_DL_CAL_DONE Data Strobe Delay Calibration Done When set, it means that sample delay chain calibration is done.
13:8	R	0x20	DS_DL

			Data Strobe Delay
7	R/W	0	DS_DL_SW_EN Data Strobe Delay Software Enable
6	/	/	/
5:0	R/W	0	DS_DL_SW Data Strobe Delay Software

Note: The register is for SMHC2 only.

4.3.7.44. SMHC FIFO Register (Default Value: 0x00000000)

Offset: 0x0200			Register Name: SMHC_FIFO_REG
Bit	R/W	Default/Hex	Description
31:0	R/W	0	TX/RX_FIFO Data FIFO

Chapter 5 Image

This section describes the image input of A64:

- [CSI](#)

5.1. CSI

5.1.1. Overview

The CSI includes the following feature:

CSI

- Support 8bit yuv422 CMOS sensor interface
- Support CCIR656 protocol for NTSC and PAL
- Maximum still capture resolution to 5M
- Maximum video capture resolution to 1080@30fps

CCI

- Compatible with i2c transmission in 7 bit slave ID + 1 bit R/W
- Automatic transmission
- 0/8/16/32 bit register address supported
- 8/16/32 bit data supported
- 64bytes-FIFO input CCI data supported
- Synchronized with CSI signal and delay trigger supported
- Repeated transmission with sync signal supported

5.1.2. Functionalities Description

5.1.2.1. Block Diagram

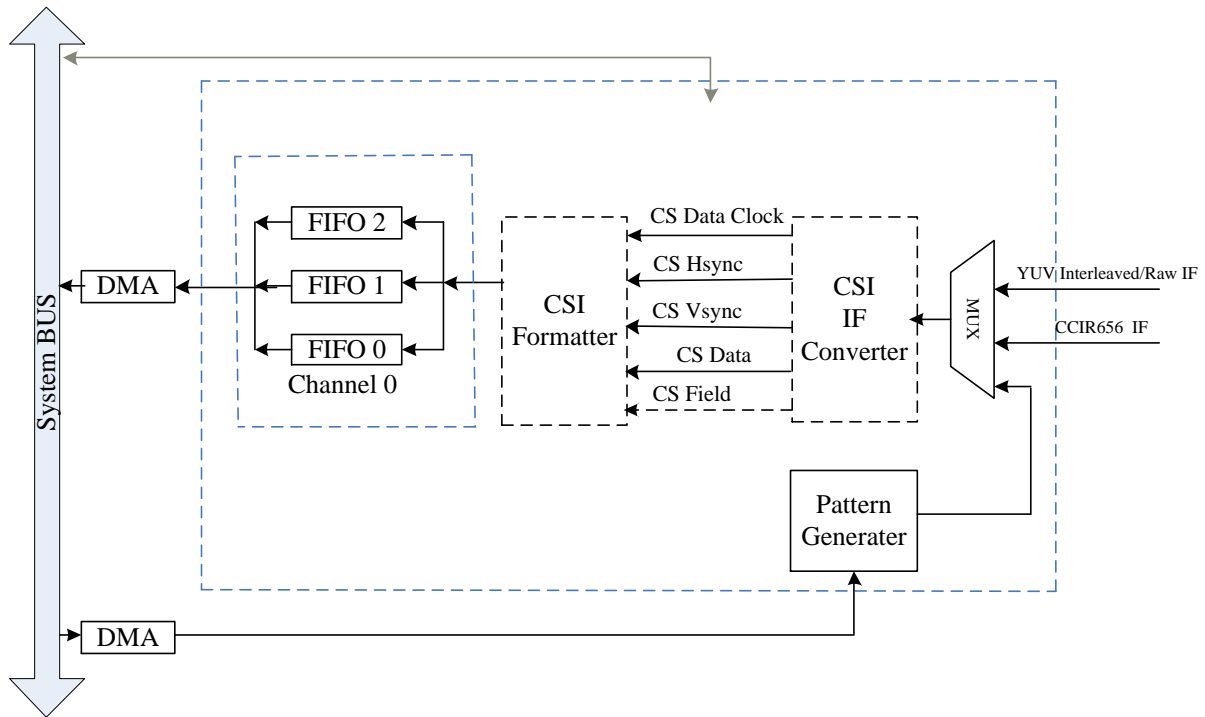

Figure 5-1. CSI Block Diagram

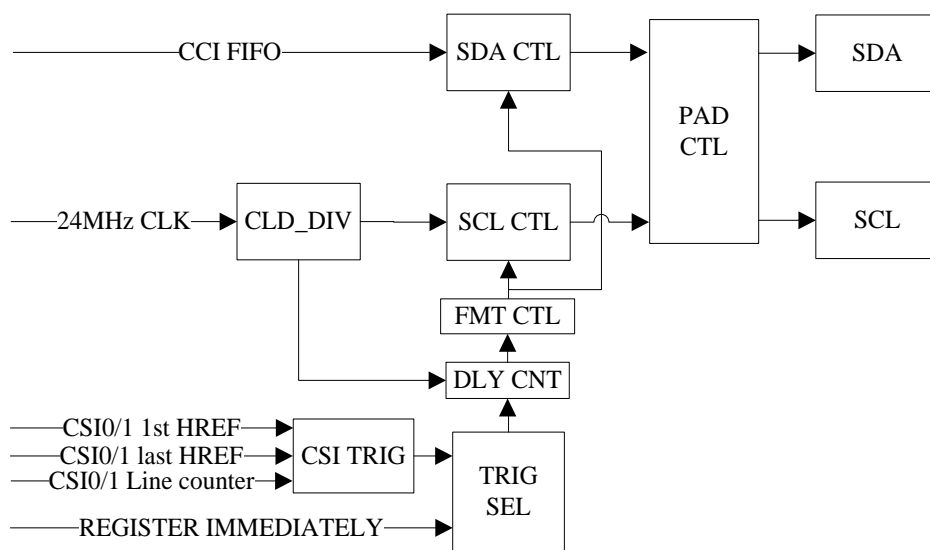

Figure 5-2. CCI Block Diagram

5.1.2.2. CSI FIFO Distribution

Interface	YUYV422 Interleaved/Raw			BT656 Interface	
Input format	YUV422		Raw	YUV422	
Output format	Planar	UV combined/MB	Raw/RGB/PRGB	Planar	UV combined/MB
CHO_FIFO0	Y pixel data	Y pixel data	All pixels data	Y	Y
CHO_FIFO1	Cb (U) pixel data	Cb (U) Cr (V) pixel data	-	Cb (U)	CbCr (UV)
CHO_FIFO2	Cr (V) pixel data	-	-	Cr (V)	

5.1.2.3. CSI Timing

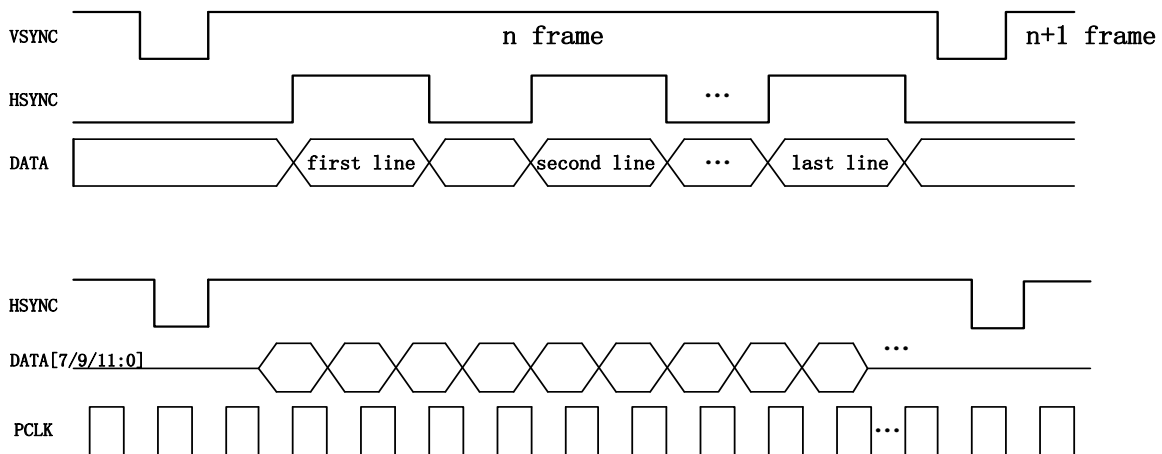

Figure 5-3. 8-bit CMOS Sensor Interface Timing
(clock rising edge sample.vsync valid = positive,hsync valid = positive)

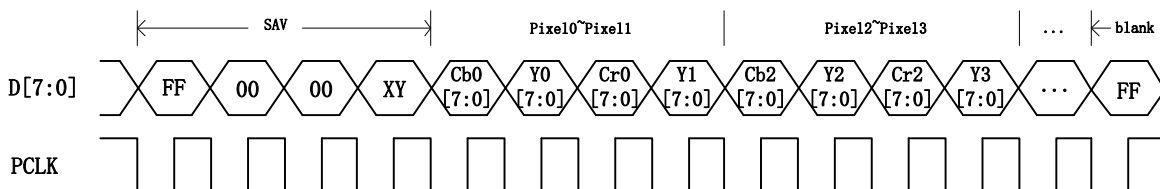

Figure 5-4. 8-bit YCbCr4:2:2 with embedded syncs(BT656) Timing

5.1.2.4. CCIR656 Header Code

The following table shows the data bit definition of CCIR656 Header.

Table 5-1. CCIR656 Header Data Bit definition

Data Bit	First Word(0xFF)	Second Word(0x00)	Third Word(0x00)	Fourth Word
CS D[9] (MSB)	1	0	0	1
CS D[8]	1	0	0	F
CS D[7]	1	0	0	V
CS D[6]	1	0	0	H
CS D[5]	1	0	0	P3
CS D[4]	1	0	0	P2
CS D[3]	1	0	0	P1
CS D[2]	1	0	0	P0
CS D[1]	x	x	x	x
CS D[0]	x	x	x	x

Note: For compatibility with 8-bit interface, CS D[1] and CS D[0] are not defined.

Decode	F	V	H	P3	P2	P1	P0
Field 1 start of active video (SAV)	0	0	0	0	0	0	0
Field 1 end of active video (EAV)	0	0	1	1	1	0	1
Field 1 SAV (digital blanking)	0	1	0	1	0	1	1
Field 1 EAV (digital blanking)	0	1	1	0	1	1	0
Field 2 SAV	1	0	0	0	1	1	1
Field 2 EAV	1	0	1	1	0	1	0
Field 2 SAV (digital blanking)	1	1	0	1	1	0	0
Field 2 EAV (digital blanking)	1	1	1	0	0	0	1

5.1.2.5. Camera Communication Interface

The CCI module support master mode i2c-compatible single read and write access to camera and related devices.

It reads a series of packet from FIFO (accessed by registers) and transmit with the format defined in specific register(or packet data).

In compact mode, format register define the slave ID, R/W flag, register address width(0/8/16/32...bit), data width(8/16/32...bit) and access counter.

In complete mode, all data and format will be loaded from memory packet.

The access counter should be set to N(N> 0), and it will read N packets from FIFO. The total bytes should not

exceed 64 for FIFO input mode.

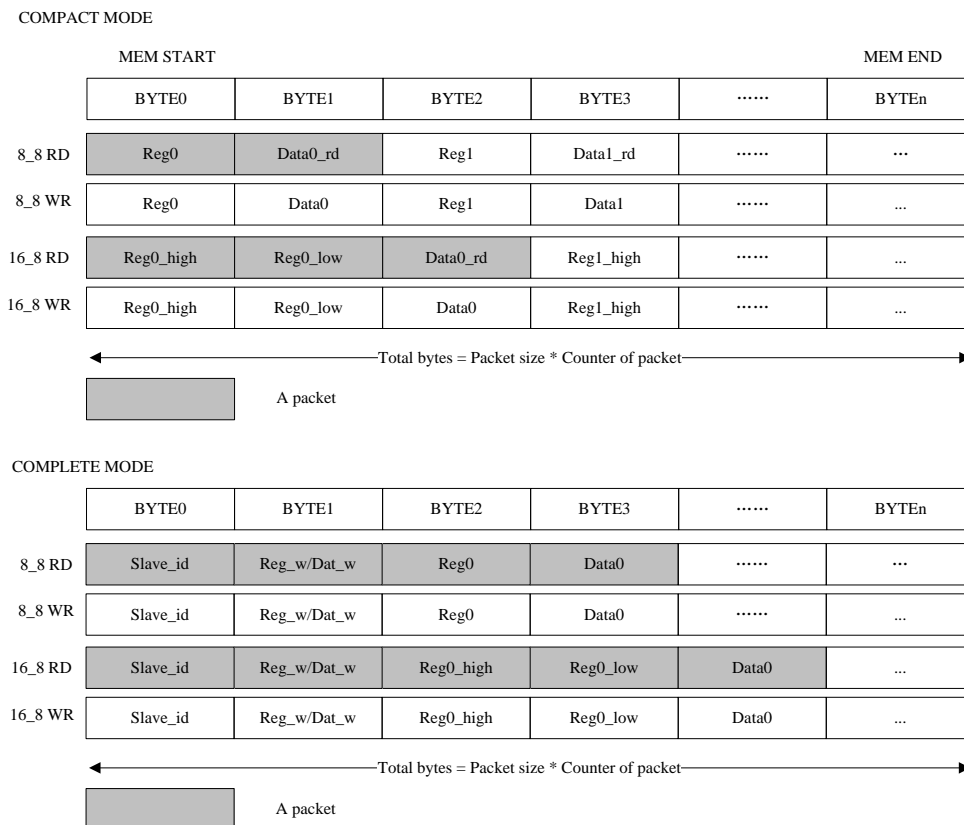

A packet is several bytes filled with register address and data(if in complete mode, slave id and width should be filled too) as the i2c access sequence defined. That is, the low address byte will be transmitted/received first. Bytes will be sent in write access, while some address will be written back with the data received in read access.

Single Access protocol supported by CCI

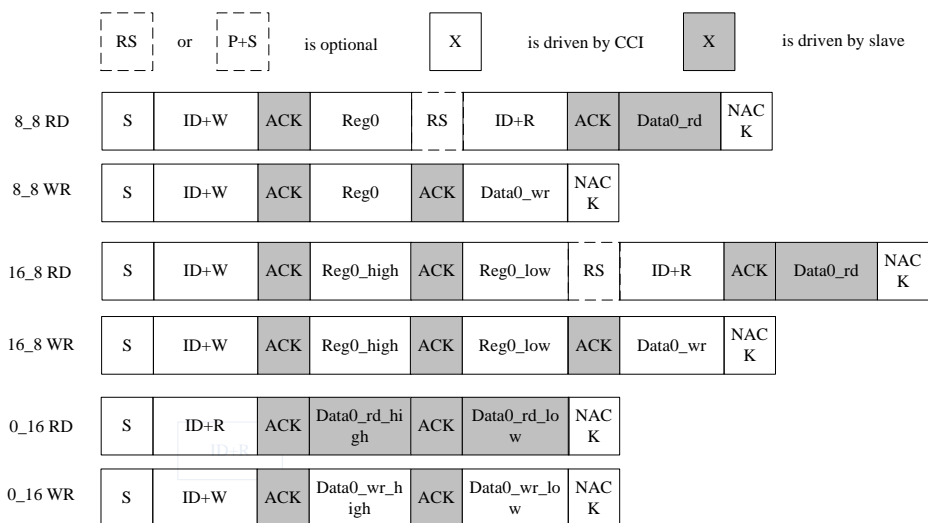

After set the execution bit, the module will do the transmission automatically and return the result - success or fail. If any access fail, the whole transmission will be stopped and returns the number when it fail in the access

counter.

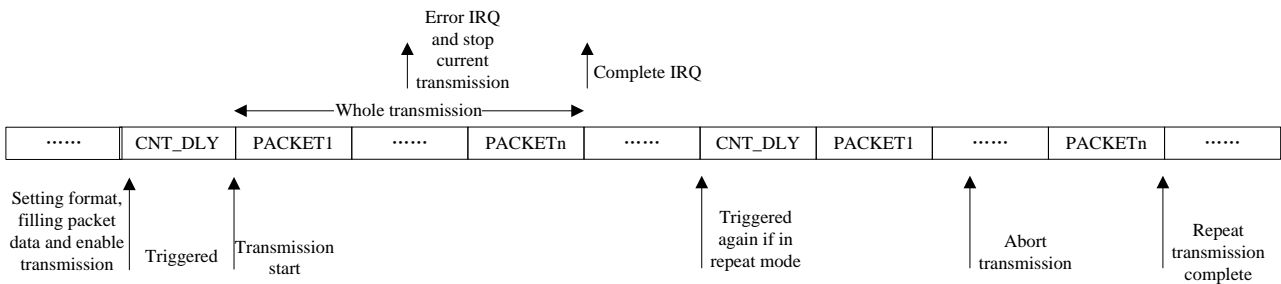

5.1.3. CSI Register list

Module Name	Base Address
CSIO	0x01CB0000

Register Name	Offset	Register name
CSIO_EN_REG	0x0000	CSI Enable register
CSIO_IF_CFG_REG	0x0004	CSI Interface Configuration Register
CSIO_CAP_REG	0x0008	CSI Capture Register
CSIO_SYNC_CNT_REG	0x000C	CSI Synchronization Counter Register
CSIO_FIFO_THRS_REG	0x0010	CSI FIFO Threshold Register
CSIO_PTN_LEN_REG	0x0030	CSI Pattern Generation Length register
CSIO_PTN_ADDR_REG	0x0034	CSI Pattern Generation Address register
CSIO_VER_REG	0x003C	CSI Version Register
CSIO_CO_CFG_REG	0x0044	CSI Channel_0 configuration register
CSIO_CO_SCALE_REG	0x004C	CSI Channel_0 scale register
CSIO_CO_F0_BUFA_REG	0x0050	CSI Channel_0 FIFO 0 output buffer-A address register
CSIO_CO_F1_BUFA_REG	0x0058	CSI Channel_0 FIFO 1 output buffer-A address register
CSIO_CO_F2_BUFA_REG	0x0060	CSI Channel_0 FIFO 2 output buffer-A address register
CSIO_CO_CAP_STA_REG	0x006C	CSI Channel_0 status register
CSIO_CO_INT_EN_REG	0x0070	CSI Channel_0 interrupt enable register
CSIO_CO_INT_STA_REG	0x0074	CSI Channel_0 interrupt status register
CSIO_CO_HSIZE_REG	0x0080	CSI Channel_0 horizontal size register
CSIO_CO_VSIZE_REG	0x0084	CSI Channel_0 vertical size register
CSIO_CO_BUF_LEN_REG	0x0088	CSI Channel_0 line buffer length register
CSIO_CO_FLIP_SIZE_REG	0x008C	CSI Channel_0 flip size register
CSIO_CO_FRM_CLK_CNT_REG	0x0090	CSI Channel_0 frame clock counter register
CSIO_CO_ACC_ITNL_CLK_CNT_REG	0x0094	CSI Channel_0 accumulated and internal clock counter register
CSIO_CO_FIFO_STAT_REG	0x0098	CSI Channel_0 FIFO Statistic Register
CSIO_CO_PCLK_STAT_REG	0x009C	CSI Channel_0 PCLK Statistic Register
CCI_CTRL	0x3000	CCI control register
CCI_CFG	0x3004	CCI transmission config register

CCI_FMT	0x3008	CCI packet format register
CCI_BUS_CTRL	0x300C	CCI bus control register
CCI_INT_CTRL	0x3014	CCI interrupt control register
CCI_LC_TRIG	0x3018	CCI line counter trigger register
CCI_FIFO_ACC	0x3100	CCI FIFO access register
CCI_RSV_REG	0x3200	CCI reserved register

5.1.4. CSI Register Description

5.1.4.1. CSI Enable Register (Default Value: 0x00000000)

Offset: 0x0000			Register Name: CSI0_EN_REG
Bit	R/W	Default/Hex	Description
31	/	/	/
30	R/W	0x0	VER_EN CSI Version Register Read Enable: 0: Disable 1: Enable
29:24	/	/	/
23:16	R/W	0x00	PTN_CYCLE Pattern generating cycle counter. The pattern in dram will be generated in cycles of PTN_CYCLE+1.
15:9	/	/	/
8	R/W	0x0	SRAM_PWDN 0: SRAM in normal 1: SRAM in power down
7:5	/	/	/
4	R/W	0x0	PTN_START CSI Pattern Generating Start 0: Finish other: Start Software write this bit to“1” to start pattern generating from DRAM. When finished, the hardware will clear this bit to“0”automatically. Generating cycles depends on PTN_CYCLE.
3	R/W	0	CLK_CNT_SPL Sampling time for clk counter per frame 0: Sampling clock counter every frame done 1: Sampling clock counter every vsync
2	R/W	0	CLK_CNT_EN clk count per frame enable
1	R/W	0	PTN_GEN_EN

			Pattern Generation Enable
0	R/W	0	CSI_EN Enable 0: Reset and disable the CSI module 1: Enable the CSI module

5.1.4.2. CSI Interface Configuration Register (Default Value: 0x00000000)

Offset: 0x0004			Register Name: CSIO_IF_CFG_REG
Bit	R/W	Default/Hex	Description
31:22	/	/	/
21	R/W	0	SRC_TYPE Source type 0: Progressed 1: Interlaced
20	R/W	0	FPS_DS Fps down sample 0: no down sample 1: 1/2 fps, only receives the first frame every 2 frames
19	R/W	0	FIELD For YUV HV timing, Field polarity 0: negative(field=0 indicate odd, field=1 indicate even) 1: positive(field=1 indicate odd, field=0 indicate even) For BT656 timing, Field sequence 0: Normal sequence (field 0 first) 1: Inverse sequence (field 1 first)
18	R/W	1	VREF_POL Vref polarity 0: negative 1: positive This register is not apply to CCIR656 interface.
17	R/W	0	HEREF_POL Href polarity 0: negative 1: positive This register is not apply to CCIR656 interface.
16	R/W	1	CLK_POL Data clock type 0: active in rising edge 1: active in falling edge
15:12	/	/	/
11:10	R/W	0	SEQ_8PLUS2 When select IF_DATA_WIDTH to be 8+2bit, odd/even pixel byte at

			CSI-D[11:4] will be rearranged to D[11:2]+2'b0 at the actual csi data bus according to these sequences: 00: 6'bx+D[9:8], D[7:0] 01: D[9:2], 6'bx+D[1:0] 10: D[7:0], D[9:8]+6'bx 11: D[7:0], 6'bx+D[9:8]
9:8	R/W	0	IF_DATA_WIDTH 00: 8 bit data bus 01: 10 bit data bus 10: 12 bit data bus 11: 8+2bit data bus
7:5	/	/	/
4:0	R/W	0	CSI_IF YUV: 00000: YUYV422 Interleaved or RAW (All data in one data bus) CCIR656: 00100: YUYV422 Interleaved or RAW (All data in one data bus) Others: Reserved

5.1.4.3. CSI Capture Register (Default Value: 0x00000000)

Offset: 0x0008			Register Name: CSIO_CAP_REG
Bit	R/W	Default/Hex	Description
31:6	/	/	/
5:2	R/W	0x0	CHO_CAP_MASK Vsync number masked before capture.
1	R/W	0x0	CHO_VCAP_ON Video capture control: Capture the video image data stream on channel 0. 0: Disable video capture If video capture is in progress, the CSI stops capturing image data at the end of the current frame, and all of the current frame data is wrote to output FIFO. 1: Enable video capture The CSI starts capturing image data at the start of the next frame.
0	R/W	0x0	CHO_SCAP_ON Still capture control: Capture a single still image frame on channel 0. 0: Disable still capture. 1: Enable still capture The CSI module starts capturing image data at the start of the next frame. The CSI module captures only one frame of image data. This bit is self clearing and always reads as a 0.

5.1.4.4. CSI Synchronization Counter Register (Default Value: 0x00000000)

Offset: 0x000C			Register Name: CSIO_SYNC_CNT_REG
Bit	R/W	Default/Hex	Description
31:24	/	/	/
23:0	R	0	SYNC_CNT The counter value between vsync of CSIO channel 0 and vsync of CSI1 channel 0 , using 24MHz.

5.1.4.5. CSI FIFO Threshold Register (Default Value: 0x040f0400)

Offset: 0x0010			Register Name: CSIO_FIFO_THRS_REG
Bit	R/W	Default/Hex	Description
31:29	/	/	/
28:26	R/W	0x1	FIFO_NEARLY_FULL_TH The threshold of FIFO being nearly full. Indicates that the ISP should stop writing. Only valid when ISP is enabled. 0~7: The smaller the value, the flag of FIFO being nearly full is easier to reach.
25:24	R/W	0x0	PTN_GEN_CLK_DIV Packet generator clock divider
23:16	R/W	0x0f	PTN_GEN_DLY Clocks delayed before pattern generating start.
15:12	/	/	/
11:00	R/W	0x400	FIFO_THRS When CSIO FIFO occupied memory exceed the threshold, dram frequency can not change.

5.1.4.6. CSI Pattern Generation Length Register (Default Value: 0x00000000)

Offset: 0x0030			Register Name: CSIO_PTN_LEN_REG
Bit	R/W	Default/Hex	Description
31:0	R/W	0x0	PTN_LEN The pattern length in byte when generating pattern.

5.1.4.7. CSI Pattern Generation Address Register (Default Value: 0x00000000)

Offset: 0x0034			Register Name: CSIO_PTN_ADDR_REG
Bit	R/W	Default/Hex	Description

31:0	R/W	0x0	PTN_ADDR The pattern DRAM address when generating pattern.
------	-----	-----	---

5.1.4.8. CSI Version Register (Default Value: 0x00000000)

Offset: 0x003C			Register Name: CSIO_VER_REG
Bit	R/W	Default/Hex	Description
31:0	R	0x0	VER Version of hardware circuit. Only can be read when version register read enable is on.

5.1.4.9. CSI Channel_0 configuration Register (Default Value: 0x00300200)

Offset: 0x0044			Register Name: CSIO_CO_CFG_REG
Bit	R/W	Default/Hex	Description
31:24	R/W	0	PAD_VAL Padding value when OUTPUT_FMT is prgb888 0x00~0xff
23:20	R/W	3	INPUT_FMT Input data format 0000: RAW stream 0001: reserved 0010: reserved 0011: YUV422 0100: YUV420 Others: reserved
19:16	R/W	0	OUTPUT_FMT Output data format When the input format is set RAW stream 0000: field-raw-8 0001: field-raw-10 0010: field-raw-12 0011: reserved 0100: field-rgb565 0101: field-rgb888 0110: field-prgb888 1000: frame-raw-8 1001: frame-raw-10 1010: frame-raw-12 1011: reserved 1100: frame-rgb565

			<p>1101: frame-rgb888 1110: frame-prgb888</p> <p>When the input format is set YUV422</p> <p>0000: field planar YCbCr 422 0001: field planar YCbCr 420 0010: frame planar YCbCr 420 0011: frame planar YCbCr 422 0100: field planar YCbCr 422 UV combined 0101: field planar YCbCr 420 UV combined 0110: frame planar YCbCr 420 UV combined 0111: frame planar YCbCr 422 UV combined 1000: field MB YCbCr 422 1001: field MB YCbCr 420 1010: frame MB YCbCr 420 1011: frame MB YCbCr 422 1100: field planar YCbCr 422 10bit UV combined 1101: field planar YCbCr 420 10bit UV combined 1110: Reserved 1111: Reserved</p> <p>When the input format is set YUV420</p> <p>0000: Reserved 0001: field planar YCbCr 420 0010: frame planar YCbCr 420 0011: Reserved 0100: Reserved 0101: field planar YCbCr 420 UV combined 0110: frame planar YCbCr 420 UV combined 0111: Reserved 1000: Reserved 1001: field MB YCbCr 420 1010: frame MB YCbCr 420 1011: Reserved 1100: Reserved 1101: field planar YCbCr 420 10bit UV combined 1110: Reserved 1111: Reserved</p> <p>Others: reserved</p>
15:14	/	/	/
13	R/W	0	<p>VFLIP_EN Vertical flip enable When enabled, the received data will be arranged in vertical flip.</p>

			0:Disable 1:Enable
12	R/W	0	HFLIP_EN Horizontal flip enable When enabled, the received data will be arranged in horizontal flip. 0:Disable 1:Enable
11:10	R/W	0	FIELD_SEL Field selection. 00: capturing with field 1. 01: capturing with field 2. 10: capturing with either field. 11: reserved
09:08	R/W	2	INPUT_SEQ Input data sequence, only valid for YUV422 and YUV420 input format. All data interleaved in one channel: 00: YUYV 01: YVYU 10: UYVY 11: VYUY Y and UV in separated channel: x0: UV x1: VU
07:02	/	/	/
01:00	R/W	0	MIN_SDR_WR_SIZE Minimum size of SDRAM block write 0: 256 bytes (if hflip is enable, always select 256 bytes) 1: 512 bytes 2: 1k bytes 3: 2k bytes

5.1.4.10. CSI Channel_0 scale Register (Default Value: 0x00000000)

Offset: 0x004C			Register Name: CSIO_CO_SCALE_REG
Bit	R/W	Default/Hex	Description
31:01	/	/	/
00	R/W	0	QUART_EN When this bit is set to 1, input image will be decimated to quarter size. All input format are supported.

5.1.4.11. CSI Channel_0 FIFO 0 output buffer-A address Register (Default Value: 0x00000000)

Offset: 0x0050			Register Name: CSIO_CO_F0_BUFA_REG
Bit	R/W	Default/Hex	Description
31:00	R/W	0	COF0_BUFA FIFO 0 output buffer-A address

5.1.4.12. CSI Channel_0 FIFO 1 output buffer-A address Register (Default Value: 0x00000000)

Offset: 0x0058			Register Name: CSIO_CO_F1_BUFA_REG
Bit	R/W	Default/Hex	Description
31:00	R/W	0	COF1_BUFA FIFO 1 output buffer-A address

5.1.4.13. CSI Channel_0 FIFO 2 output buffer-A address Register (Default Value: 0x00000000)

Offset: 0x0060			Register Name: CSIO_CO_F2_BUFA_REG
Bit	R/W	Default/Hex	Description
31:00	R/W	0	COF2_BUFA FIFO 2 output buffer-A address

5.1.4.14. CSI Channel_0 status Register (Default Value: 0x00000000)

Offset: 0x006C			Register Name: CSIO_CO_CAP_STA_REG
Bit	R/W	Default/Hex	Description
31:03	/	/	/
02	R	0	FIELD_STA The status of the received field 0: Field 0 1: Field 1
01	R	0	VCAP_STA Video capture in progress Indicates the CSI is capturing video image data (multiple frames). The bit is set at the start of the first frame after enabling video capture. When software disables video capture, it clears itself after the last pixel of the current frame is captured.
00	R	0	SCAP_STA Still capture in progress Indicates the CSI is capturing still image data (single frame). The bit is set

			<p>at the start of the first frame after enabling still frame capture. It clears itself after the last pixel of the first frame is captured.</p> <p>For CCIR656 interface, if the output format is frame planar YCbCr 420 mode, the frame end means the field2 end, the other frame end means filed end.</p>
--	--	--	--

5.1.4.15. CSI Channel_0 interrupt enable Register (Default Value: 0x00000000)

Offset: 0x0070			Register Name: CSIO_CO_INT_EN_REG
Bit	R/W	Default/Hex	Description
31:08	/	/	/
07	R/W	0	<p>VS_INT_EN vsync flag The bit is set when vsync come. And at this time load the buffer address for the coming frame. So after this irq come, change the buffer address could only effect next frame</p>
06	R/W	0	<p>HB_OF_INT_EN Hblank FIFO overflow The bit is set when 3 FIFOs still overflow after the hblank.</p>
05	R/W	0	<p>MUL_ERR_INT_EN Multi-channel writing error Indicates error has been detected for writing data to a wrong channel.</p>
04	R/W	0	<p>FIFO2_OF_INT_EN FIFO 2 overflow The bit is set when the FIFO 2 become overflow.</p>
03	R/W	0	<p>FIFO1_OF_INT_EN FIFO 1 overflow The bit is set when the FIFO 1 become overflow.</p>
02	R/W	0	<p>FIFO0_OF_INT_EN FIFO 0 overflow The bit is set when the FIFO 0 become overflow.</p>
01	R/W	0	<p>FD_INT_EN Frame done Indicates the CSI has finished capturing an image frame. Applies to video capture mode. The bit is set after each completed frame capturing data is wrote to buffer as long as video capture remains enabled.</p>
00	R/W	0	<p>CD_INT_EN Capture done Indicates the CSI has completed capturing the image data. For still capture, the bit is set when one frame data has been wrote to buffer. For video capture, the bit is set when the last frame has been wrote to buffer after video capture has been disabled.</p>

			For CCIR656 interface, if the output format is frame planar YCbCr 420 mode, the frame end means the field2 end, the other frame end means field end.
--	--	--	--

5.1.4.16. CSI Channel_0 interrupt status Register (Default Value: 0x00000000)

Offset: 0x0074			Register Name: CSIO_CO_INT_STA_REG
Bit	R/W	Default/Hex	Description
31:08	/	/	/
07	R/W	0	VS_PD vsync flag
06	R/W	0	HB_OF_PD Hblank FIFO overflow
05	R/W	0	MUL_ERR_PD Multi-channel writing error
04	R/W	0	FIFO2_OF_PD FIFO 2 overflow
03	R/W	0	FIFO1_OF_PD FIFO 1 overflow
02	R/W	0	FIFO0_OF_PD FIFO 0 overflow
01	R/W	0	FD_PD Frame done
00	R/W	0	CD_PD Capture done

5.1.4.17. CSI Channel_0 horizontal size Register (Default Value: 0x05000000)

Offset: 0x0080			Register Name: CSIO_CO_INT_STA_REG
Bit	R/W	Default/Hex	Description
31:29	/	/	/
28:16	R/W	500	HOR_LEN Horizontal pixel unit length. Valid pixel of a line.
15:13	/	/	/
12:00	R/W	0	HOR_START Horizontal pixel unit start. Pixel is valid from this pixel.

5.1.4.18. CSI Channel_0 vertical size Register (Default Value: 0x01E00000)

Offset: 0x0084	Register Name: CSIO_CO_VSIZE_REG
----------------	---

Bit	R/W	Default/Hex	Description
31:29	/	/	/
28:16	R/W	1E0	VER_LEN Vertical line length. Valid line number of a frame.
15:13	/	/	/
12:00	R/W	0	VER_START Vertical line start. data is valid from this line.

5.1.4.19. CSI Channel_0 buffer length Register (Default Value: 0x01400280)

Offset: 0x0088			Register Name: CSIO_CO_BUF_LEN_REG
Bit	R/W	Default/Hex	Description
31:30	/	/	/
29:16	R/W	140	BUF_LEN_C Buffer length of chroma C in a line. Unit is byte.
15:14	/	/	/
13:00	R/W	280	BUF_LEN Buffer length of luminance Y in a line. Unit is byte.

5.1.4.20. CSI Channel_0 flip size Register (Default Value: 0x01E00280)

Offset: 0x008C			Register Name: CSIO_CO_FLIP_SIZE_REG
Bit	R/W	Default/Hex	Description
31:29	/	/	/
28:16	R/W	1E0	VER_LEN Vertical line number when in vflip mode.
15:13	/	/	/
12:00	R/W	280	VALID_LEN Valid components of a line when in flip mode.

5.1.4.21. CSI Channel_0 frame clock counter Register (Default Value: 0x00000000)

Offset: 0x0090			Register Name: CSIO_CO_FRM_CLK_CNT_REG
Bit	R/W	Default/Hex	Description
31:24	/	/	/
23:00	R	0	FRM_CLK_CNT Counter value between every frame. For instant hardware frame rate statics. The internal counter is added by one every 24MHz clock cycle. When

			frame done or vsync comes, the internal counter value is sampled to FRM_CLK_CNT, and cleared to 0.
--	--	--	--

5.1.4.22. CSI Channel_0 accumulated and internal clock counter Register (Default Value: 0x00000000)

Offset: 0x0094			Register Name: CSIO_CO_ACC_ITNL_CLK_CNT_REG
Bit	R/W	Default/Hex	Description
31:24	R	0	<p>ACC_CLK_CNT</p> <p>The accumulated value of FRM_CLK_CNT for software frame rate statics. Every interrupt of frame done, the software check this accumulated value and clear it to 0. If the ACC_CLK_CNT is larger than 1, the software has lost frame.</p> <p>When frame done or vsync comes, ACC_CLK_CNT = ACC_CLK_CNT + 1, and cleared to 0 when writing 0 to this register.</p>
23:00	R	0	<p>ITNL_CLK_CNT</p> <p>The instant value of internal frame clock counter.</p> <p>When frame done interrupt comes, the software can query this counter for judging whether it is the time for updating the double buffer address registers.</p>

5.1.4.23. CSI Channel_0 FIFO Statistic Register (Default Value: 0x00000000)

Offset: 0x0098			Register Name: CSIO_CO_FIFO_STAT_REG
Bit	R/W	Default/Hex	Description
31:12	/	/	/
11:00	R	0	<p>FIFO_FRM_MAX</p> <p>Indicates the maximum depth of FIFO being occupied for whole frame. Update at every vsync or framedone.</p>

5.1.4.24. CSI Channel_0 PCLK Statistic Register (Default Value: 0x00007FFF)

Offset: 0x009C			Register Name: CSIO_CO_PCLK_STAT_REG
Bit	R/W	Default/Hex	Description
31	/	/	/
30:16	R	0	<p>PCLK_CNT_LINE_MAX</p> <p>Indicates maximum pixel clock counter value for each line. Update at every vsync or framedone.</p>
15	/	/	/
14:00	R	0x7fff	<p>PCLK_CNT_LINE_MIN</p> <p>Indicates minimum pixel clock counter value for each line.</p>

			Update at every vsync or framedone.
--	--	--	-------------------------------------

5.1.4.25. CCI Control Register (Default Value: 0x00000000)

Offset: 0x3000			Register Name: CCI_CTRL_REG
Bit	R/W	Default/Hex	Description
31	R/W	0	<p>SINGLE_TRAN</p> <p>0: Transmission idle</p> <p>1: Start single transmission</p> <p>Automatically cleared to '0' when finished. Abort current transmission immediately if changing from '1' to '0'. If slave not respond for the expected status over the time defined by TIMEOUT, current transmission will stop. PACKET_CNT will return the sequence number when transmission fail. All format setting and data will be loaded from registers and FIFO when transmission start.</p>
30	R/W	0	<p>REPEAT_TRAN</p> <p>0: transmission idle</p> <p>1: repeated transmission</p> <p>When this bit is set to 1, transmission repeats when trigger signal (such as VSYNC/ VCAP done) repeats.</p> <p>If changing this bit from '1' to '0' during transmission, the current transmission will be guaranteed then stop.</p>
29	R/W	0	<p>RESTART_MODE</p> <p>0: RESTART</p> <p>1: STOP+START</p> <p>Define the CCI action after sending register address.</p>
28	R/W	0	<p>READ_TRAN_MODE</p> <p>0: send slave_id+W</p> <p>1: do not send slave_id+W</p> <p>Note:Setting this bit to 1 if reading from a slave which register width is equal to 0.</p>
27:24	R	0	<p>TRAN_RESULT</p> <p>000: OK</p> <p>001: FAIL</p> <p>Other: Reserved</p>
23:16	R	/	<p>CCI_STA</p> <p>0x00: bus error</p> <p>0x08: START condition transmitted</p> <p>0x10: Repeated START condition transmitted</p> <p>0x18: Address + Write bit transmitted, ACK received</p> <p>0x20: Address + Write bit transmitted, ACK not received</p> <p>0x28: Data byte transmitted in master mode, ACK received</p> <p>0x30: Data byte transmitted in master mode, ACK not received</p>

			<p>0x38: Arbitration lost in address or data byte</p> <p>0x40: Address + Read bit transmitted, ACK received</p> <p>0x48: Address + Read bit transmitted, ACK not received</p> <p>0x50: Data byte received in master mode, ACK received</p> <p>0x58: Data byte received in master mode, ACK not received</p> <p>0x01: Timeout when sending 9th SCL clk</p> <p>Other: Reserved</p>
15:2	/	/	/
1	R/W	0	<p>SOFT_RESET</p> <p>0: normal</p> <p>1: reset</p>
0	R/W	0	<p>CCI_EN</p> <p>0: Module disable</p> <p>1: Module enable</p>

5.1.4.26. CCI Transmission Configuration Register (Default Value: 0x1000000)

Offset: 0x3004			Register Name: CCI_CFG_REG
Bit	R/W	Default/Hex	Description
31:24	R/W	0x10	<p>TIMEOUT_N</p> <p>When sending the 9th clock, assert fail signal when slave device did not response after N*FSCL cycles. And software must do a reset to CCI module and send a stop condition to slave.</p>
23:16	R/W	0x00	<p>INTERVAL</p> <p>Define the interval between each packet in 40*FSCL cycles. 0~255</p>
15	R/W	0	<p>PACKET_MODE</p> <p>Select where to load slave id / data width</p> <p>0: Compact mode</p> <p>1: Complete mode</p> <p>In compact mode, slave id/register width / data width will be loaded from CCI_FMT register, only address and data read from memory.</p> <p>In complete mode, they will be loaded from packet memory.</p>
14:7	/	/	/
6:4	R/W	0	<p>TRIG_MODE</p> <p>Transmit mode:</p> <p>000: Immediately, no trigger</p> <p>001: Reserved</p> <p>010: CSIO int trigger</p> <p>011: CSI1 int trigger</p>
3:0	R/W	0	<p>CSI_TRIG</p> <p>CSI Int trig signal select:</p> <p>0000: First HREF start</p> <p>0001: Last HREF done</p>

			0010: Line counter trigger other: Reserved
--	--	--	---

5.1.4.27. CCI Packet Format Register (Default Value: 0x00110001)

Offset: 0x3008			Register Name: CCI_FMT_REG
Bit	R/W	Default/Hex	Description
31:25	R/W	0	SLV_ID 7bit address
24	R/W	0	CMD 0: write 1: read
23:20	R/W	1	ADDR_BYTE How many bytes be sent as address 0~15
19:16	R/W	1	DATA_BYTE How many bytes be sent/received as data 1~15 Normally use ADDR_DATA with 0_2, 1_1, 1_2, 2_1, 2_2 access mode. If DATA bytes is 0, transmission will not start. In complete mode, the ADDR_BYTE and DATA_BYTE is defined in a byte's high/low 4bit.
15:0	R/W	1	PACKET_CNT FIFO data be transmitted as PACKET_CNT packets in current format. Total bytes not exceed 32bytes.

5.1.4.28. CCI Bus Control Register (Default Value: 0x00002500)

Offset: 0x300C			Register Name: CCI_BUS_REG
Bit	R/W	Default/Hex	Description
31:16	R/W	0	DLY_CYC 0~65535 FSCL cycles between each transmission
15	R/W	0	DLY_TRIG 0: disable 1: execute transmission after internal counter delay when triggered
14:12	R/W	0x2	CLK_N CCI bus sampling clock $F_0=24\text{MHz}/2^{\text{CLK_N}}$
11:8	R/W	0x5	CLK_M CCI output SCL frequency is $\text{FSCL}=F_1/10=(F_0/(\text{CLK_M}+1))/10$
7	R	/	SCL_STA SCL current status
6	R	/	SDA_STA

			SDA current status
5	R/W	0	SCL_PEN SCL PAD enable
4	R/W	0	SDA_PEN SDA PAD enable
3	R/W	0	SCL_MOV SCL manual output value
2	R/W	0	SDA_MOV SDA manual output value
1	R/W	0	SCL_MOE SCL manual output en
0	R/W	0	SDA_MOE SDA manual output en

5.1.4.29. CCI Interrupt Control Register (Default Value: 0x00000000)

Offset: 0x3014			Register Name: CCI_INT_CTRL_REG
Bit	R/W	Default/Hex	Description
31:18	/	/	/
17	R/W	0	S_TRAN_ERR_INT_EN
16	R/W	0	S_TRAN_COM_INT_EN
15:2	/	/	/
1	R/W	0	S_TRAN_ERR_PD
0	R/W	0	S_TRAN_COM_PD

5.1.4.30. CCI Line Counter Trigger Control Register (Default Value: 0x00000000)

Offset: 0x3018			Register Name: CCI_LC_REG
Bit	R/W	Default/Hex	Description
31:13	/	/	/
12:0	R/W	0	LN_CNT 0~8191: line counter send trigger when 1st~8192th line is received.

5.1.4.31. CCI FIFO Access Register (Default Value: 0x00000000)

Offset: 0x3100~0x313f			Register Name: CCI_FIFO_ACC_REG
Bit	R/W	Default/Hex	Description
31:0	R/W	0	DATA_FIFO From 0x100 to 0x13f, CCI data fifo is 64bytes, used in fifo input mode. CCI

			transmission read/write data from/to fifo in byte.
--	--	--	--

Chapter 6 Display

This chapter describes the A64 display system from following perspectives:

- DE2.0
- TCON

The following figure shows the block diagram of display system:

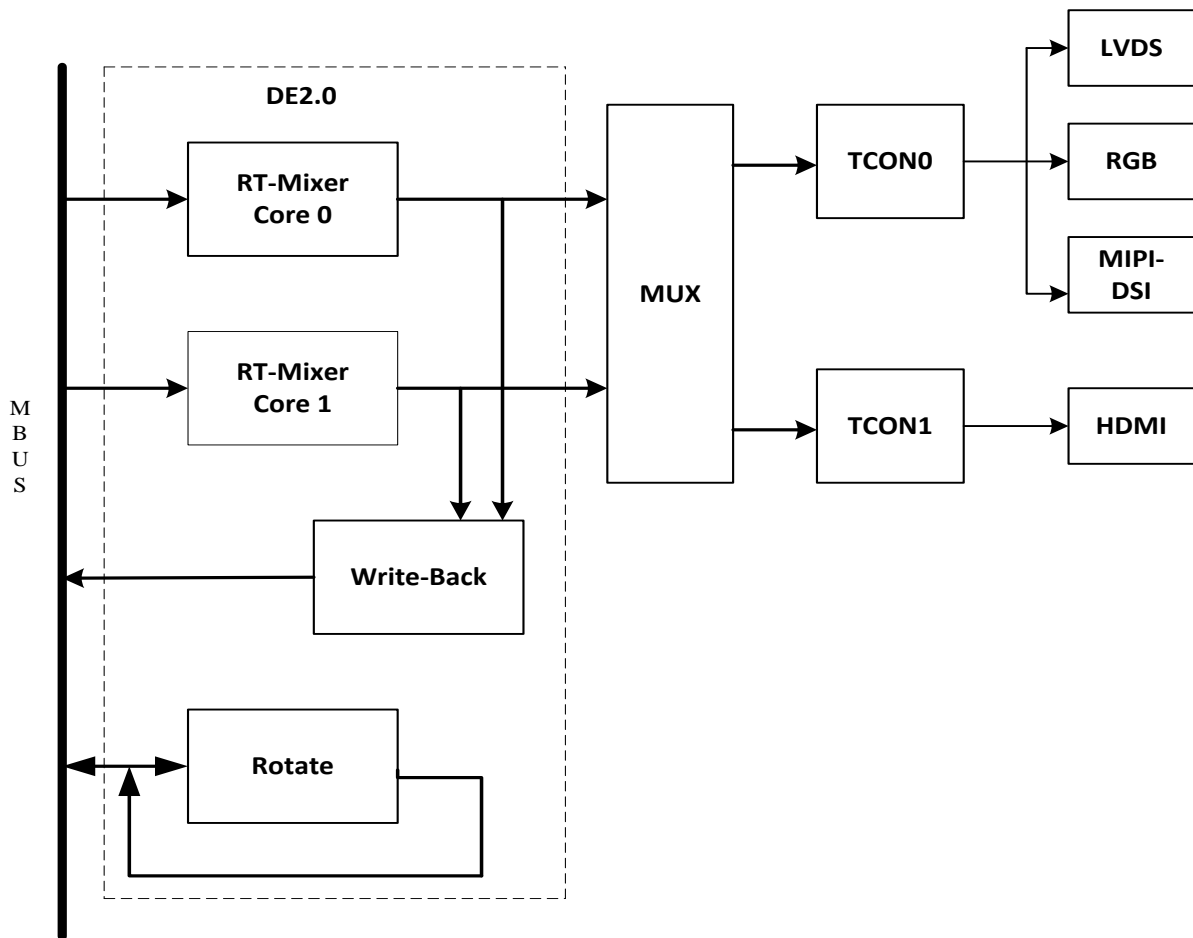

Figure 6-1. Display System Block Diagram

6.1. DE2.0

6.1.1. Overview

- Output size up to 4096x4096
- Support four alpha blending channel for main display, two channel for aux display
- Support four overlay layers in each channel, and has a independent scaler
- Support potter-duff compatible blending operation
- Support input format YUV422/YUV420/YUV411/ARGB8888/XRGB8888/RGB888/ARGB4444/ARGB1555 and RGB565
- Support Frame Packing/Top-and-Bottom/Side-by-side Full/Side-by-Side Half 3D format data
- Support SmartColor 2.0 for excellent display experience
 - Adaptive edge sharpening
 - Adaptive color enhancement
 - Adaptive contrast enhancement and fresh tone rectify
- Support writeback and rotation for high effieient dual display and miracast

6.2. TCON

6.2.1. Overview

- Support LVDS interface with single link, up to 1366x768@60fps
- Support RGB interface with DE/SYNC mode, up to 1920x1200@60fps
- Support serial RGB/dummy RGB/CCIR656 interface, up to 800x480@60fps
- Support i80 interface with 18/16/9/8 bit, support TE, up to 800x480@60fps
- Support 4-lanes MIPI DSI up to 1920x1200@60fps
- Support HDMI1.4 with HDCP1.2 up to 4K@30fps
- Support pixel format: RGB888, RGB666 and RGB565
- Dither function from RGB666/RGB565 to RGB888
- Gamma correction with R/G/B channel independence
- 4 interrupts for programmer LCD output
- 2 input source: DE sources

6.2.2. Block Diagram

The following figure shows the block diagram of dual TCON controller.

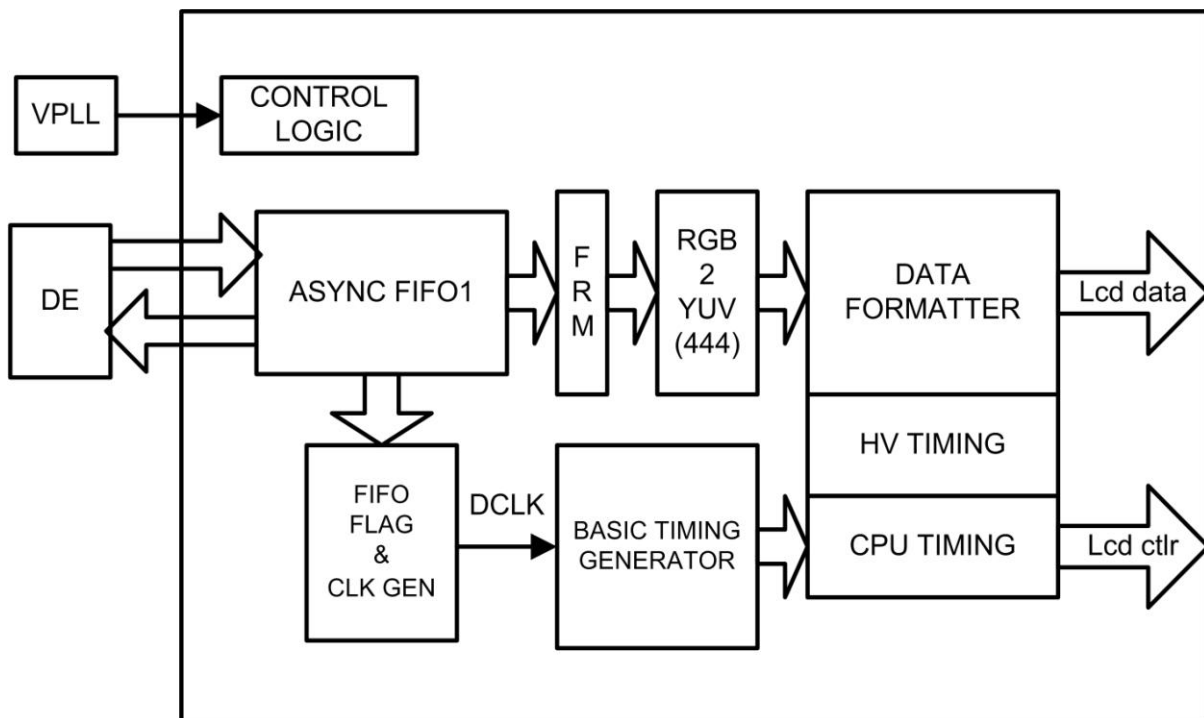

Figure 6-1. TCON0 Block Diagram

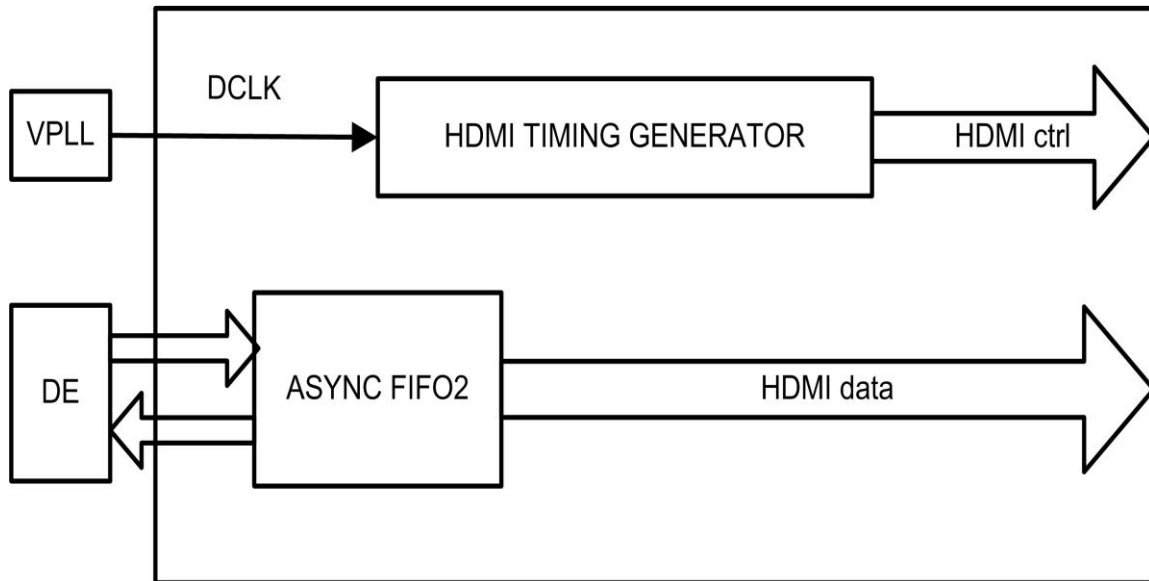

Figure 6-2. TCON1 Block Diagram

6.2.3. Functionalities Description

6.2.3.1. Panel Interface

HV_I/F(Sync+DE mode)

HV I/F is also known as Sync + DE mode, which is widely used in TFT LCD module for PMP/MP4 applications.

Its signals are define as:

Main Signal	I/O type	Definition And Description
Vsync	O	Vertical sync, indicates one new frame
Hsync	O	Horizontal sync, indicate one new scan line
DCLK	O	Dot clock, pixel data are sync by this clock
LDE	O	LCD data enable
LD[23..0]	O	18Bit RGB/YUV output from input FIFO for panel

HV control signals are active low.

The following figures show the Panel interface timing ,Parallel mode and serial mode timing of TCON0.

Vertical Timing

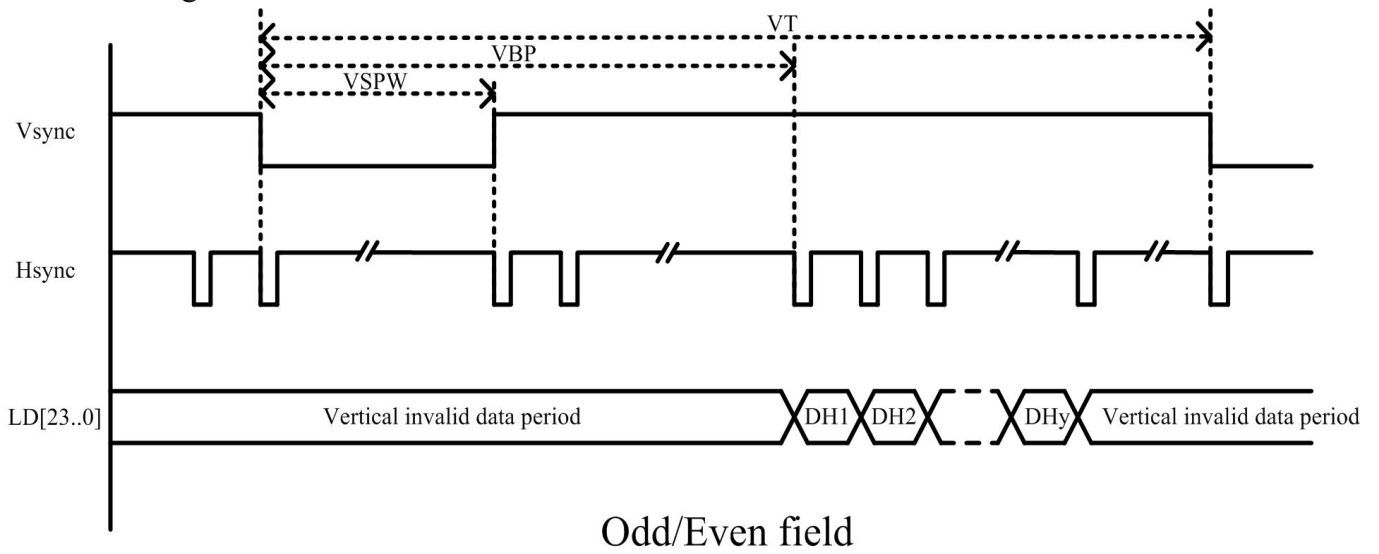

Figure 6-3. Panel Interface Timing of Odd/Even field

Vertical Timing

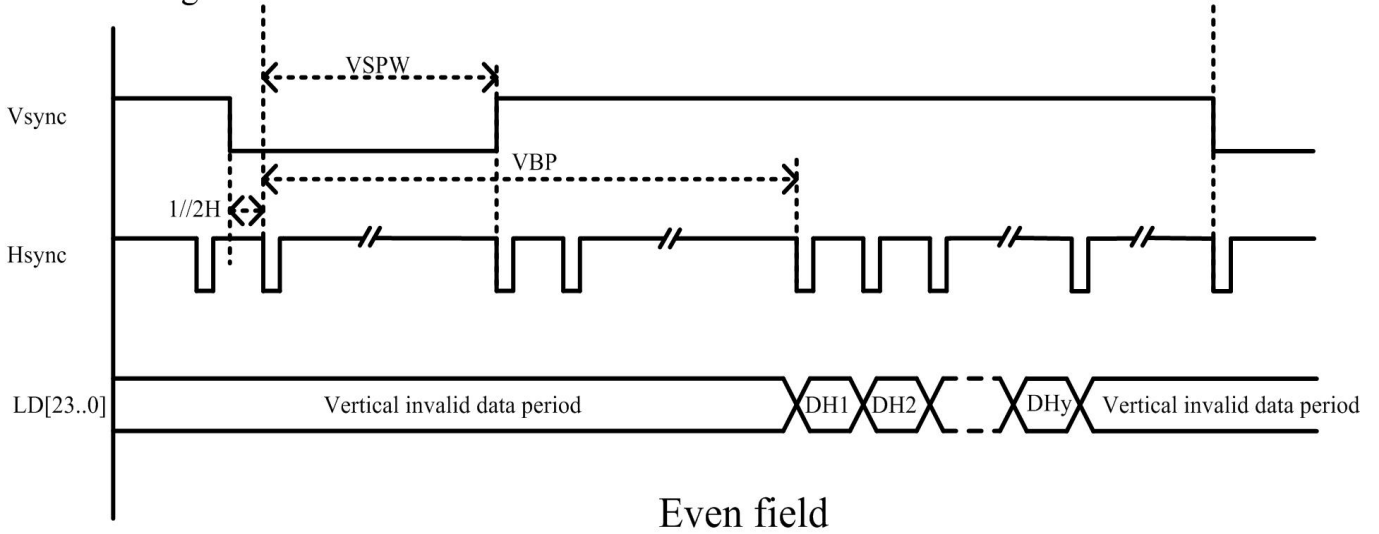

Figure 6-4. Panel Interface Timing of Even field

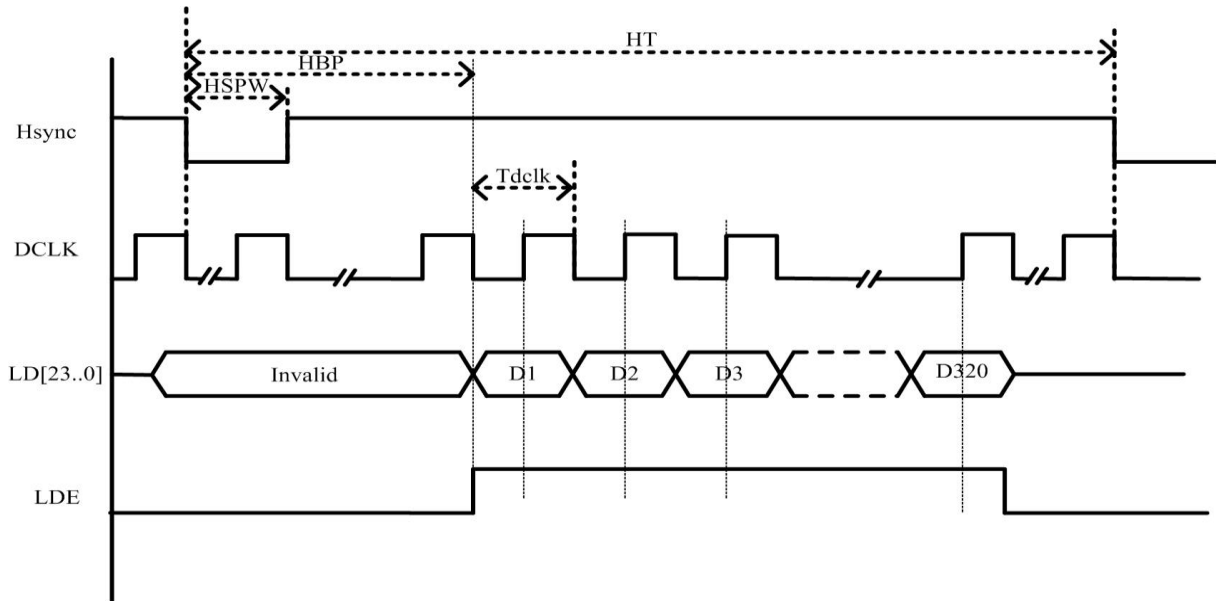

Figure 6-5.Parallel Mode Horizontal Timing

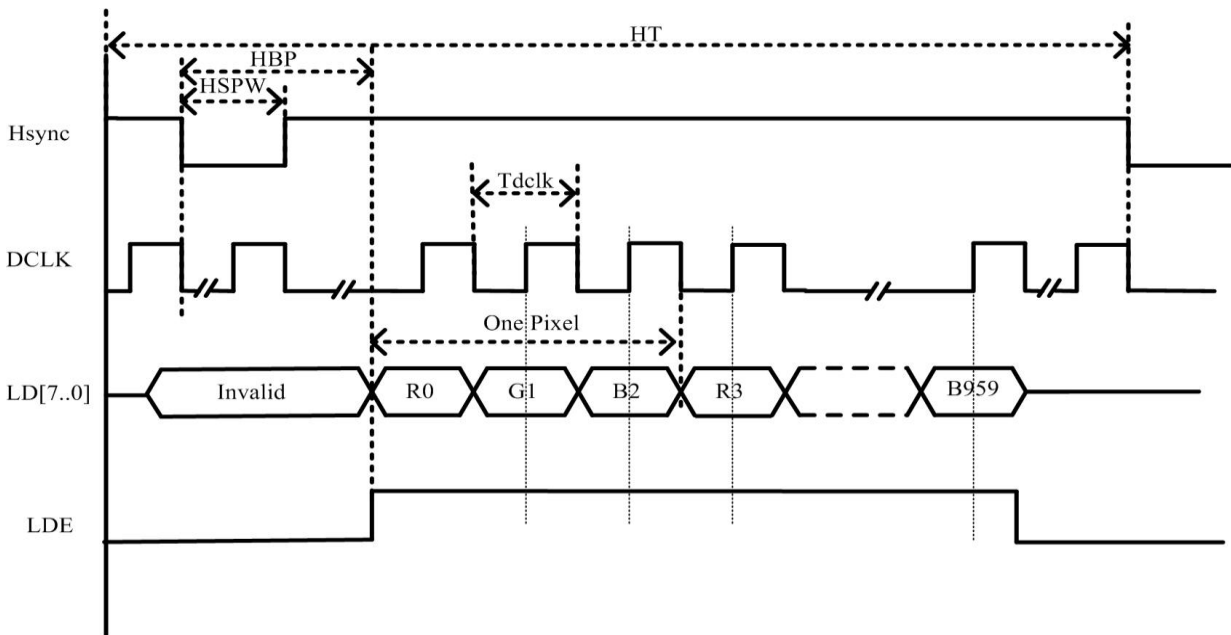

Figure 6-6. Serial Mode Horizontal Timing

CCIR output SAV/EAV sync signal

When in HV serial YUV output mode, it's timing is CCIR656/601 compatible. SAV add right before active area every line; EAV add right after active area every line.

It logic are:

F = "0" for Field 1 F = "1" for Field 2

V = "1" during vertical blanking

H = "0" at SAV H = "1" at EAV

P3–P0 = protection bits

$$P3 = V \oplus H$$

$$P2 = F \oplus H$$

$$P1 = F \oplus V$$

$$P0 = F \oplus V \oplus H$$

Where \oplus represents the exclusive-OR function

The 4 byte SAV/EAV sequences are:

	8-bit Data								10-bit Data	
	D9 (MSB)	D8	D7	D6	D5	D4	D3	D2	D1	D0
preamble	1	1	1	1	1	1	1	1	1	1
	0	0	0	0	0	0	0	0	0	0
	0	0	0	0	0	0	0	0	0	0
Status word	1	F	V	H	P3	P2	P1	P0	0	0

CPU_I/F

CPU I/F LCD panel is most common interface for small size, low resolution LCD panels.

CPU control signals are active low.

Main Signal	I/O type	Definition And Description
CS	O	Chip select, active low
WR	O	Write strobe, active low
RD	O	Read strobe, active low
A1	O	Address bit, controlled by "LCD_CPU I/F" BIT26/25
D[23..0]	I/O	Digital RGB output signal

The following figure relationship between basic timing and CPU timing. WR is 180 degree delay of DCLK; CS is active when pixel data are valid; RD is always set to 1; A1 are set by "Lcd_CPU I/F". When CPU I/F is in IDLE state, it can generate WR/RD timing by setting "Lcd_CPU I/F". CS strobe is one DCLK width, WR/RD strobe is half DCLK width.

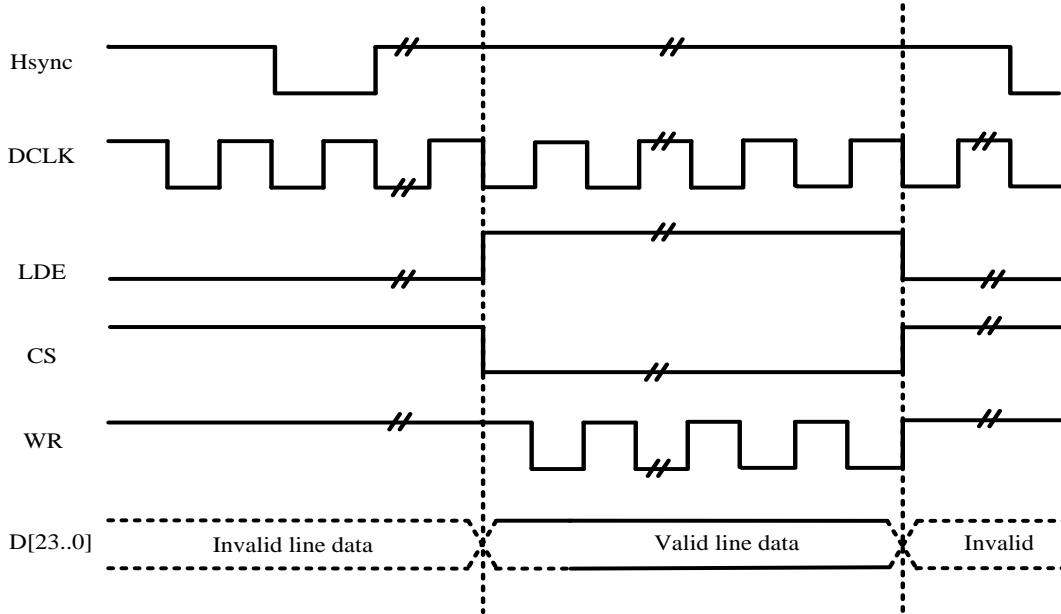

Figure 6-7. CPU I/F LCD panel

LVDS_IF

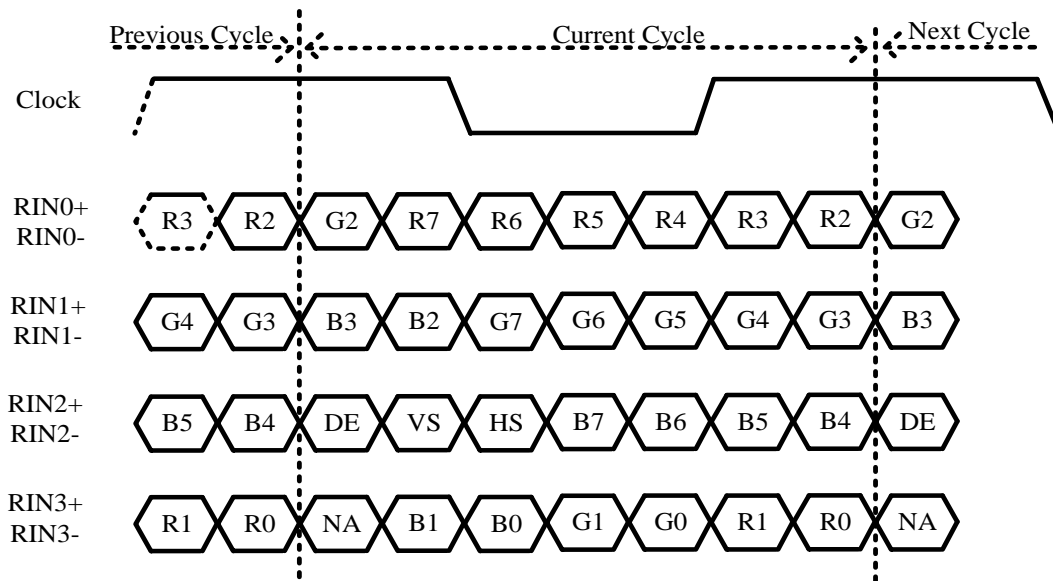

Figure 6-8. LVDS_IF JEDIA mode

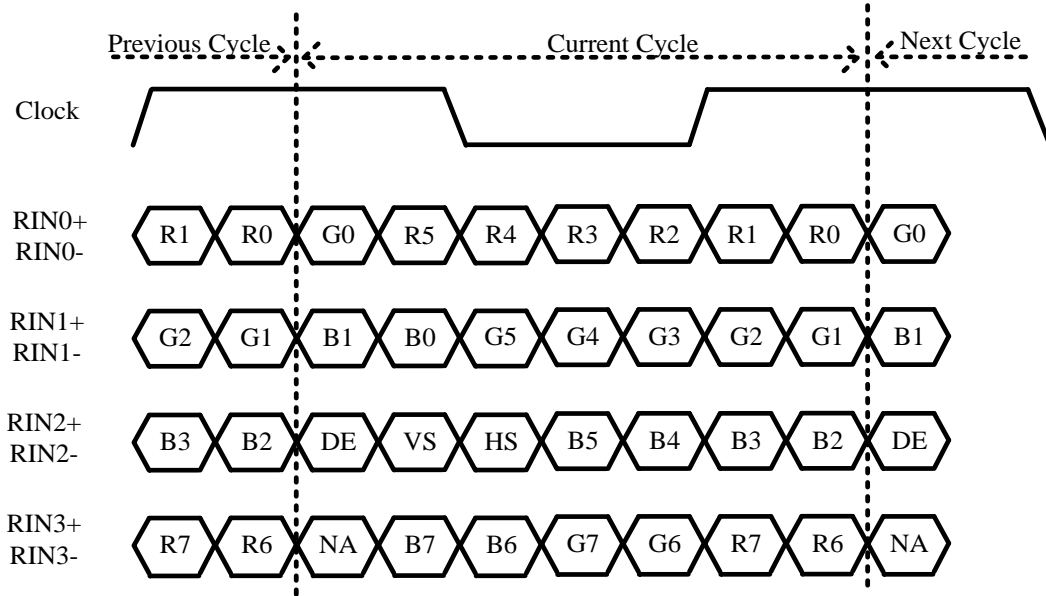

Figure 6-9. LVDS_IF NS mode

6.2.3.2. RGB gamma correction

Function: This module correct the RGB input data of DE0 .

A 256*8*3 Byte register file is used to store the gamma table. The following is the layout:

Offset	Value
0x400, 0x401, 0x402	{ B0[7:0], G0[7:0], R0[7:0] }
0x404,	{ B1[7:0], G1[7:0], R1[7:0] }
.....
0x4FC	{ B255[7:0], G255[7:0], R255[7:0] }

6.2.3.3. CEU module

Function: This module enhance color data from DE0 .

$$R' = R_r * R + R_g * G + R_b * B + R_c$$

$$G' = G_r * R + G_g * G + G_b * B + G_c$$

$$B' = B_r * R + B_g * G + B_b * B + B_c$$

Note:

$R_r, R_g, R_b, G_r, G_g, G_b, B_r, B_g, B_b$ s13 (-16,16)

R_c, G_c, B_c s19 (-16384, 16384)

R, G, B u8 [0-255]

R' have the range of [Rmin ,Rmax]

G' have the range of [Rmin ,Rmax]

B' have the range of [Rmin ,Rmax]

6.2.3.4. CMAP module

Function: This module map color data from DE

Every 4 input pixels are as a unit. A unit is divided into 12 bytes. Output byte can select one of those 12 bytes. Note that even line and odd line can be different, and output can be 12 bytes(4 pixels) or reduce to 6 bytes(2 pixels).

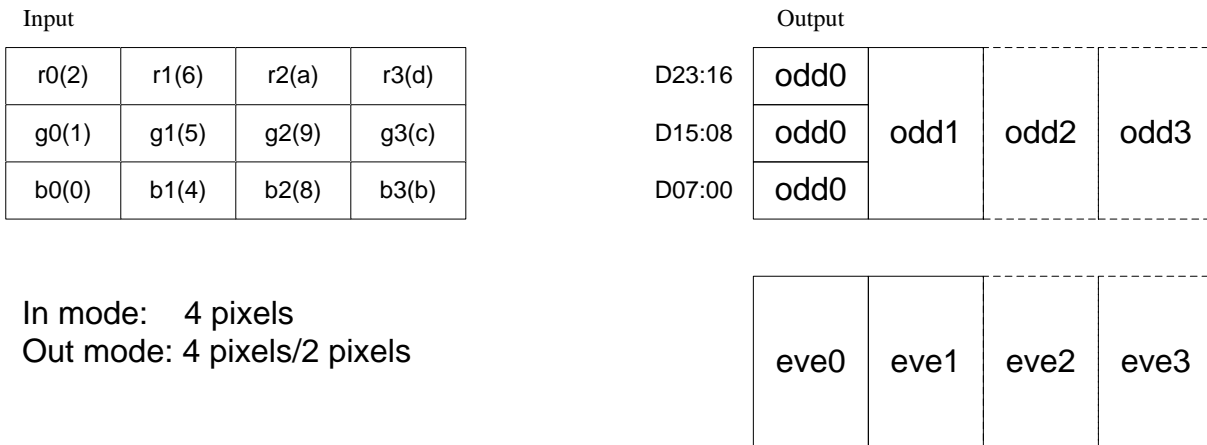

6.2.4. TCON0 Module Register List

Module Name	Base Address
TCON0	0x01C0C000

Register Name	Offset	Description
TCON_GCTL_REG	0x000	TCON global control register
TCON_GINT0_REG	0x004	TCON global interrupt register0
TCON_GINT1_REG	0x008	TCON global interrupt register1
TCON0_FRM_CTL_REG	0x010	TCON FRM control register
TCON0_FRM_SEED_REG	0x014+N*0x04	TCON FRM seed register (N=0,1,2,3,4,5)
TCON0_FRM_TAB_REG	0x02C+N*0x04	TCON FRM table register (N=0,1,2,3)
TCON0_3D_FIFO_REG	0x03C	TCON0 3D fifo register
TCON0_CTL_REG	0x040	TCON0 control register
TCON0_DCLK_REG	0x044	TCON0 data clock register
TCON0_BASIC0_REG	0x048	TCON0 basic timing register0
TCON0_BASIC1_REG	0x04C	TCON0 basic timing register1

TCONO_BASIC2_REG	0x050	TCONO basic timing register2
TCONO_BASIC3_REG	0x054	TCONO basic timing register3
TCONO_HV_IF_REG	0x058	TCONO hv panel interface register
TCONO_CPU_IF_REG	0x060	TCONO cpu panel interface register
TCONO_CPU_WR_REG	0x064	TCONO cpu panel write data register
TCONO_CPU_RD0_REG	0x068	TCONO cpu panel read data register0
TCONO_CPU_RD1_REG	0x06C	TCONO cpu panel read data register1
TCONO_LVDS_IF_REG	0x084	TCONO lvds panel interface register
TCONO_IO_POL_REG	0x088	TCONO IO polarity register
TCONO_IO_TRI_REG	0x08C	TCONO IO trigger register
TCON_CEU_CTL_REG	0x100	TCON CEU control register
TCON_CEU_COEF_MUL_REG	0x110+N*0x04	TCON CEU coefficient register0 (N=0,1,2,4,5,6,8,9,10)
TCON_CEU_COEF_ADD_REG	0x11C+N*0x10	TCON CEU coefficient register1 (N=0,1,2)
TCON_CEU_COEF_RANG_REG	0x140+N*0x04	TCON CEU coefficient register2 (N=0,1,2)
TCONO_CPU_TRIO_REG	0x160	TCONO cpu panel trigger register0
TCONO_CPU_TRI1_REG	0x164	TCONO cpu panel trigger register1
TCONO_CPU_TRI2_REG	0x168	TCONO cpu panel trigger register2
TCONO_CPU_TRI3_REG	0x16C	TCONO cpu panel trigger register3
TCONO_CPU_TRI4_REG	0x170	TCONO cpu panel trigger register4
TCONO_CPU_TRI5_REG	0x174	TCONO cpu panel trigger register5
TCON_CMAP_CTL_REG	0x180	TCON color map control register
TCON_CMAP_ODD0_REG	0x190	TCON color map odd line register0
TCON_CMAP_ODD1_REG	0x194	TCON color map odd line register1
TCON_CMAP_EVEN0_REG	0x198	TCON color map even line register0
TCON_CMAP_EVEN1_REG	0x19C	TCON color map even line register1
TCON_SAFE_PERIOD_REG	0x1F0	TCON safe period register
TCONO_LVDS_ANA0_REG	0x220	TCON LVDS analog register0
TCONO_GAMMA_TABLE_REG	0x400-0x7FF	
TCONO_3D_FIFO_BIST_REG	0xFF4	
TCON_TRI_FIFO_BIST_REG	0xFF8	

6.2.5. TCON0 Module Register Description

6.2.5.1. TCON Global Control Register (Default Value: 0x00000000)

Offset: 0x0000			Register Name: TCON_GCTL_REG
Bit	R/W	Default/Hex	Description

31	R/W	0	TCON_En 0: disable 1: enable When it's disabled, the module will be reset to idle state.
30	R/W	0	TCON_Gamma_En 0: disable 1: enable
29:1	/	/	/
0	R/W	0	IO_Map_Sel 0: TCON0 1: TCON1 Note: this bit determined which IO_INV/IO_TRI are valid

6.2.5.2. TCON Global Interrupt Register0 (Default Value: 0x00000000)

Offset: 0x0004			Register Name: TCON_GINT0_REG
Bit	R/W	Default/Hex	Description
31	R/W	0	TCON0_Vb_Int_En 0: disable 1: enable
30	R/W	0	TCON1_Vb_Int_En 0: disable 1: enable
29	R/W	0	TCON0_Line_Int_En 0: disable 1: enable
28	R/W	0	TCON1_Line_Int_En 0: disable 1: enable
27	R/W	0	TCON0_Tri_Finish_Int_En 0: disable 1: enable
26:	R/W	0	TCON0_Tri_Counter_Int_En 0: disable 1: enable
25:16	/	/	/
15	R/W	0	TCON0_Vb_Int_Flag Asserted during vertical no-display period every frame. Write 0 to clear it.
14	R/W	0	TCON1_Vb_Int_Flag Asserted during vertical no-display period every frame. Write 0 to clear it.

13	R/W	0	TCON0_Line_Int_Flag Trigger when SY0 match the current TCON0 scan line Write 0 to clear it.
12	R/W	0	TCON1_Line_Int_Flag Trigger when SY1 match the current TCON1 scan line Write 0 to clear it.
11	R/W	0	TCON0_Tri_Finish_Int_Flag Trigger when cpu trigger mode finish Write 0 to clear it.
10	R/W	0	TCON0_Tri_Counter_Int_Flag Trigger when tri counter reache this value Write 0 to clear it.
9	R/W	0	TCON0_Tri_Underflow_Flag Only used in dsi video mode, tri when sync by dsi but not finish Write 0 to clear it.
8:0	/	/	/

6.2.5.3. TCON Global Interrupt Register1 (Default Value: 0x00000000)

Offset: 0x0008			Register Name: TCON_GINT1_REG
Bit	R/W	Default/Hex	Description
31:28	/	/	/
27:16	R/W	0	TCON0_Line_Int_Num scan line for TCON0 line trigger(including inactive lines) Setting it for the specified line for trigger0. Note: SY0 is writable only when LINE_TRG0 disable.
15:12	/	/	/
11:0	R/W	0	TCON1_Line_Int_Num scan line for TCON1 line trigger(including inactive lines) Setting it for the specified line for trigger 1. Note: SY1 is writable only when LINE_TRG1 disable.

6.2.5.4. TCON FRM Control Register0 (Default Value: 0x00000000)

Offset: 0x0010			Register Name: TCON0_FRM_CTL_REG
Bit	R/W	Default/Hex	Description
31	R/W	0	TCON0_Frm_En 0:disable 1:enable
30:7	/	/	/
6	R/W	0	TCON0_Frm_Mode_R

			0: 6bit frm output 1: 5bit frm output
5	R/W	0	TCON0_Frm_Mode_G 0: 6bit frm output 1: 5bit frm output
4	R/W	0	TCON0_Frm_Mode_B 0: 6bit frm output 1: 5bit frm output
3:2	/	/	/
1:0	R/W	0	TCON0_Frm_Test 00: FRM 01: half 5/6bit, half FRM 10: half 8bit, half FRM 11: half 8bit, half 5/6bit

6.2.5.5. TCON FRM Seed Register0 (Default Value: 0x00000000)

Offset: 0x0014+N*0x04 (N=0,1,2,3,4,5)			Register Name: TCON0_FRM_SEED_REG
Bit	R/W	Default/Hex	Description
31:25	/	/	/
24:0	R/W	0	Seed_Value N=0: Pixel_Seed_R N=1: Pixel_Seed_G N=2: Pixel_Seed_B N=3: Line_Seed_R N=4: Line_Seed_G N=5: Line_Seed_B Note: avoid set it to 0

6.2.5.6. TCON FRM Table Register0 (Default Value: 0x00000000)

Offset: 0x002C+N*0x04 (N=0,1,2,3)			Register Name: TCON0_FRM_TAB_REG
Bit	R/W	Default/Hex	Description
31:0	R/W	0	Frm_Table_Value

6.2.5.7. TCON 3D FIFO Register0 (Default Value: 0x00000000)

Offset: 0x003C			Register Name: TCON0_3D_FIFO_REG
Bit	R/W	Default/Hex	Description
31	R/W	0	3D_FIFO_BIST_EN 0: disable 1: enable
30:14	/	/	/
13:4	R/W	0	3D_FIFO_HALF_LINE_SIZE Note: The number of data in half line=3D_FIFO_HALF_LINE_SIZE+1 only valid when 3D_FIFO_SETTING set as 2
3:2	/	/	/
1:0	R/W	0	3D_FIFO_SETTING 0: by pass 1: used as normal FIFO 2: used as 3D interlace FIFO 3: reserved

6.2.5.8. TCON0 Control Register (Default Value: 0x00000000)

Offset: 0x040			Register Name: TCON0_CTL_REG
Bit	R/W	Default/Hex	Description
31	R/W	0	TCON0_En 0: disable 1: enable Note: It executes at the beginning of the first blank line of TCON0 timing.
30:29	/	/	/
28	R/W	0	TCON0_Work_Mode 0: normal 1: dynamic freq
27:26	/	/	/
25:24	R/W	0	TCON0_IF 00: HV(Sync+DE) 01: 8080 I/F 1x:reserved
23	R/W	0	TCON0_RB_Swap 0: default 1: swap RED and BLUE data at FIFO1
22	/	/	/
21	R/W	0	TCON0_FIFO1_Rst Write 1 and then 0 at this bit will reset FIFO 1

			Note: 1 holding time must more than 1 DCLK
20	/	/	/
19:9	/	/	/
8:4	R/W	0	TCONO_Start_Delay STA delay NOTE: valid only when TCON0_EN == 1
3	/	/	/
2:0	R/W	0	TCONO_SRC_SEL: 000: DE0 001: reserved 010: reserved 011: reserved 100: Test Data all 0 101: Test Data all 1 11x: reserved

6.2.5.9. TCON0 Data Clock Register (Default Value: 0x00000000)

Offset: 0x044			Register Name: TCONO_DCLK_REG
Bit	R/W	Default/Hex	Description
31:28	R/W	0	TCONO_Dclk_En LCLK_EN[3:0] :TCON0 clock enable 4'h0, 'h4,4'h6,4'ha7:dclk_en=0;dclk1_en=0;dclk2_en=0;dclkm2_en=0; 4'h1: dclk_en = 1; dclk1_en = 0; dclk2_en = 0; dclkm2_en = 0; 4'h2: dclk_en = 1; dclk1_en = 0; dclk2_en = 0; dclkm2_en = 1; 4'h3: dclk_en = 1; dclk1_en = 1; dclk2_en = 0; dclkm2_en = 0; 4'h5: dclk_en = 1; dclk1_en = 0; dclk2_en = 1; dclkm2_en = 0; 4'h8,4'h9,4'ha,4'hb,4'hc,4'hd,4'he,4'hf: dclk_en = 1; dclk1_en = 1; dclk2_en = 1; dclkm2_en = 1;
27:7	/	/	/
6:0	R/W	0	TCONO_Dclk_Div Tdclk = Tsclk * DCLKDIV Note: 1.if dclk1&dclk2 used, DCLKDIV >=6 2.if dclk only, DCLKDIV >=1

6.2.5.10. TCON0 Basic0 Register (Default Value: 0x00000000)

Offset: 0x048			Register Name: TCON0_BASIC0_REG
Bit	R/W	Default/Hex	Description
31:28	/	/	/
27:16	R/W	0	TCON0_X Panel width is X+1
15:12	/	/	/
11:0	R/W	0	TCON0_Y Panel height is Y+1

6.2.5.11. TCON0 Basic1 Register (Default Value: 0x00000000)

Offset: 0x04C			Register Name: TCON0_BASIC1_REG
Bit	R/W	Default/Hex	Description
31	R/W	0	Reservd
30:29	/	/	/
28:16	R/W	0	HT Thcycle = (HT+1) * Tdclk Computation 1) parallel:HT = X + BLANK Limitation: 1) parallel :HT >= (HBP +1) + (X+1) +2 2) serial 1: HT >= (HBP +1) + (X+1) *3+2 3) serial 2: HT >= (HBP +1) + (X+1) *3/2+2
15:12	/	/	/
11:0	R/W	0	HBP horizontal back porch (in dclk) Thbp = (HBP +1) * Tdclk

6.2.5.12. TCON0 Basic2 Register (Default Value: 0x00000000)

Offset: 0x050			Register Name: TCON0_BASIC2_REG
Bit	R/W	Default/Hex	Description
31:29	/	/	/
28:16	R/W	0	VT TVT = (VT)/2 * Thsync Note: VT/2 >= (VBP+1) + (Y+1) +2
15:12	/	/	/
11:0	R/W	0	VBP

			$Tvbp = (VBP + 1) * Thsync$
--	--	--	-----------------------------

6.2.5.13. TCON0 Basic3 Register (Default Value: 0x00000000)

Offset: 0x054			Register Name: TCON0_BASIC3_REG
Bit	R/W	Default/Hex	Description
31:26	/	/	/
25:16	R/W	0	HSPW $Thspw = (HSPW+1) * Tdclk$ Note: $HT > (HSPW+1)$
15:10	/	/	/
9:0	R/W	0	VSPW $Tvspw = (VSPW+1) * Thsync$ Note: $VT/2 > (VSPW+1)$

6.2.5.14. TCON0 HV Panel Interface Register (Default Value: 0x00000000)

Offset: 0x058			Register Name: TCON0_HV_IF_REG
Bit	R/W	Default/Hex	Description
31:28	R/W	0	HV_Mode 0000: 24bit/1cycle parallel mode 1000: 8bit/3cycle RGB serial mode(RGB888) 1010: 8bit/4cycle Dummy RGB(DRGB) 1011: 8bit/4cycle RGB Dummy(RGBD) 1100: 8bit/2cycle YUV serial mode(CCIR656)
27:26	R/W	0	RGB888_SM0 serial RGB888 mode Output sequence at odd lines of the panel (line 1, 3, 5, 7...) 00: R→G→B 01: B→R→G 10: G→B→R 11: R→G→B
25:24	R/W	0	RGB888_SM1 serial RGB888 mode Output sequence at even lines of the panel (line 2, 4, 6, 8...) 00: R→G→B 01: B→R→G 10: G→B→R 11: R→G→B
23:22	R/W	0	YUV_SM serial YUV mode Output sequence 2-pixel-pair of every scan line

			00: YUYV 01: VYU 10: UYVY 11: VYUY
21:20	R/W	0	YUV EAV/SAV F line delay 0:F toggle right after active video line 1:delay 2 line(CCIR PAL) 2:delay 3 line(CCIR NTSC) 3:reserved
19	R/W	0	CCIR_CSC_Dis 0: enable 1: disable Only valid when HV mode is "1100", select '0' TCON convert source from RGB to YUV
18:0	/	/	/

6.2.5.15. TCON0 CPU Panel Interface Register (Default Value: 0x00000000)

Offset: 0x060			Register Name: TCON0_CPU_IF_REG
Bit	R/W	Default/Hex	Description
31:28	R/W	0	CPU_Mode 0000: 18bit/256K mode 0010: 16bit mode0 0100: 16bit mode1 0110: 16bit mode2 1000: 16bit mode3 1010: 9bit mode 1100: 8bit 256K mode 1110: 8bit 65K mode xxx1: 24bit for DSI
27	/	/	/
26	R/W	0	DA pin A1 value in 8080 mode auto/flash states
25	R/W	0	CA pin A1 value in 8080 mode WR/RD execute
24	/	/	/
23	R	0	Wr_Flag 0:write operation is finishing 1:write operation is pending
22	R	0	Rd_Flag 0:read operation is finishing 1:read operation is pending
21:18	/	/	/

17	R/W	0	AUTO auto Transfer Mode: If it's 1, all the valid data during this frame are write to panel. Note: This bit is sampled by Vsync
16	R/W	0	FLUSH direct transfer mode: If it's enabled, FIFO1 is regardless of the HV timing, pixels data keep being transferred unless the input FIFO was empty. Data output rate control by DCLK.
15:6	/	/	/
5:4	R/W	0	/
3	R/W	0	Trigger_FIFO_Bist_En 0: disable 1: enable Entry addr is 0xFF8
2	R/W	0	Trigger_FIFO_En 0:enable 1:disable
1	R/W	0	Trigger_Start write '1' to start a frame flush, write'0' has no effect. this flag indicated frame flush is running software must make sure write '1' only when this flag is '0'.
0	R/W	0	Trigger_En 0: trigger mode disable 1: trigger mode enable

6.2.5.16. TCON0 CPU Panel Write Data Register (Default Value: 0x00000000)

Offset: 0x064			Register Name: TCON0_CPU_WR_REG
Bit	R/W	Default/Hex	Description
31:24	/	/	/
23:0	W	0	Data_Wr data write on 8080 bus, launch a write operation on 8080 bus

6.2.5.17. TCON0 CPU Panel Read Data 0 Register (Default Value: 0x00000000)

Offset: 0x068			Register Name: TCON0_CPU_RD0_REG
Bit	R/W	Default/Hex	Description
31:24	/	/	/
23:0	R	/	Data_Rd0 data read on 8080 bus, launch a new read operation on 8080 bus

6.2.5.18. TCON0 CPU Panel Read Data 1 Register (Default Value: 0x00000000)

Offset: 0x06C			Register Name: TCON0_CPU_RD1_REG
Bit	R/W	Default/Hex	Description
31:24	/	/	/
23:0	R	/	Data_Rd1 data read on 8080 bus, without a new read operation on 8080 bus

6.2.5.19. TCON0 LVDS Panel Interface Register (Default Value: 0x00000000)

Offset: 0x084			Register Name: TCON0_LVDS_IF_REG
Bit	R/W	Default/Hex	Description
31	R/W	0	TCON0_LVDS_En 0: disable 1: enable
30	/	/	/
29	R/W	0	TCON0_LVDS_Even_Odd_Dir 0: normal 1: reverse
28	R/W	0	TCON0_LVDS_Dir 1: normal 2: reverse NOTE: LVDS direction
27	R/W	0	TCON0_LVDS_Mode 0: NS mode 1: JEIDA mode
26	R/W	0	TCON0_LVDS_BitWidth 0: 24bit 1: 18bit
25	R/W	0	TCON0_LVDS_DeBug_En 0: disable 1: enable
24	R/W	0	TCON0_LVDS_DeBug_Mode 0: mode0 RANDOM DATA 1: mode1 output CLK period=7/2 LVDS CLK period
23	R/W	0	TCON0_LVDS_Correct_Mode 0: mode0 1: mode1
22:21	/	/	/
20	R/W	0	TCON0_LVDS_Clk_Sel

			0: MIPI PLL 1: TCON0 CLK
19:5	/	/	/
4	R/W	0	TCON0_LVDS_CLK_Polarity 0: reverse 1: normal
3:0	R/W	0	TCON0_LVDS_Data_Polarity 0: reverse 1: normal

6.2.5.20. TCON0 IO Polarity Register (Default Value: 0x00000000)

Offset: 0x088			Register Name: TCON0_IO_POL_REG
Bit	R/W	Default/Hex	Description
31	R/W	0	IO_Output_Sel 0: normal output 1: register output when set as '1', d[23:0], io0, io1,io3 sync to dclk
30:28	R/W	0	DCLK_Sel 000: used DCLK0(normal phase offset) 001: used DCLK1(1/3 phase offset) 010: used DCLK2(2/3 phase offset) 101: DCLK0/2 phase 0 100: DCLK0/2 phase 90 reserved
27	R/W	0	IO3_Inv 0: not invert 1: invert
26	R/W	0	IO2_Inv 0: not invert 1: invert
25	R/W	0	IO1_Inv 0: not invert 1: invert
24	R/W	0	IO0_Inv 0: not invert 1: invert
23:0	R/W	0	Data_Inv TCON0 output port D[23:0] polarity control, with independent bit control: 0s: normal polarity 1s: invert the specify output

6.2.5.21. TCON0 IO Trigger Register (Default Value: 0x00000000)

Offset: 0x08C			Register Name: TCON0_IO_TRI_REG
Bit	R/W	Default/Hex	Description
31:29	/	/	/
28	/	/	RGB_Endian 0: normal 1: bits_invert
27	R/W	1	IO3_Output_Tri_En 1: disable 0: enable
26	R/W	1	IO2_Output_Tri_En 1: disable 0: enable
25	R/W	1	IO1_Output_Tri_En 1: disable 0: enable
24	R/W	1	IO0_Output_Tri_En 1: disable 0: enable
23:0	R/W	0xFFFFFFFF	Data_Output_Tri_En TCON0 output port D[23:0] output enable, with independent bit control: 1s: disable 0s: enable

6.2.5.22. TCON CEU Control Register (Default Value: 0x00000000)

Offset: 0x100			Register Name: TCON_CEU_CTL_REG
Bit	R/W	Default/Hex	Description
31	R/W	0	CEU_en 0: bypass 1: enable
30:0	/	/	/

6.2.5.23. TCON CEU Coefficient Mul Register (Default Value: 0x00000000)

Offset: 0x110+N*0x04 (N=0,1,2,4,5,6,8,9,10)			Register Name: TCON_CEU_COEF_MUL_REG
Bit	R/W	Default/Hex	Description
31:13	/	/	/
12:0	R/W	0	CEU_Coef_Mul_Value

			signed 13bit value, range of (-16,16) N=0: Rr N=1: Rg N=2: Rb N=4: Gr N=5: Gg N=6: Gb N=8: Br N=9: Bg N=10: Bb
--	--	--	---

6.2.5.24. TCON CEU Coefficient Add Register (Default Value: 0x00000000)

Offset: 0x11C+N*0x10 (N=0,1,2)			Register Name: TCON_CEU_COEF_ADD_REG
Bit	R/W	Default/Hex	Description
31:19	/	/	/
18:0	R/W	0	CEU_Coef_Add_Value signed 19bit value, range of (-16384, 16384) N=0: Rc N=1: Gc N=2: Bc

6.2.5.25. TCON CEU Coefficient Range Register (Default Value: 0x00000000)

Offset: 0x140+N*0x04 (N=0,1,2)			Register Name: TCON_CEU_COEF_RANGE_REG
Bit	R/W	Default/Hex	Description
31:24	/	/	/
23:16	R/W	0	CEU_Coef_Range_Min unsigned 8bit value, range of [0,255]
15:8	/	/	/
7:0	R/W	0	CEU Coef_Range_Max unsigned 8bit value, range of [0,255]

6.2.5.26. TCON0 CPU Panel Trigger0 Register (Default Value: 0x00000000)

Offset: 0x160			Register Name: TCON0_CPU_TRIO_REG
Bit	R/W	Default/Hex	Description
31:28	/	/	/

27:16	R/W	0	Block_Space should be set >20*pixel_cycle
15:12	/	/	/
11:0	R/W	0	Block_Size

6.2.5.27. TCON0 CPU Panel Trigger1 Register (Default Value: 0x00000000)

Offset: 0x164			Register Name: TCON0_CPU_TRI1_REG
Bit	R/W	Default/Hex	Description
31:16	R	0	Block_Current_Num
15:0	R/W	0	Block_Num

6.2.5.28. TCON0 CPU Panel Trigger2 Register (Default Value: 0x00000000)

Offset: 0x168			Register Name: TCON0_CPU_TRI2_REG
Bit	R/W	Default/Hex	Description
31:16	R/W	0x20	Start_Delay Tdly = (Start_Delay +1) * be_clk*8
15	R/W	0	Trans_Start_Mode 0: ecc_fifo+tri_fifo 1: tri_fifo
14:13	R/W	0	Sync_Mode 0x: auto 10: 0 11: 1
12:0	R/W	0	Trans_Start_Set

6.2.5.29. TCON0 CPU Panel Trigger3 Register (Default Value: 0x00000000)

Offset: 0x16C			Register Name: TCON0_CPU_TRI3_REG
Bit	R/W	Default/Hex	Description
31:30	/	/	/
29:28	R/W	0	Tri_Int_Mode 00: disable 01: counter mode 10: te rising mode 11: te falling mode when set as 01, Tri_Counter_Int occur in cycle of (Count_N+1) × (Count_M+1) × 4 dclk. when set as 10 or 11, io0 is map as TE input.

27:24	/	/	/
23:8	R/W	0	Counter_N
7:0	R/W	0	Counter_M

6.2.5.30. TCON0 CPU Panel Trigger4 Register (Default Value: 0x00000000)

Offset: 0x170			Register Name: TCON0_CPU_TRI4_REG
Bit	R/W	Default/Hex	Description
31:29	/	/	/
28	R/W	0	Plug_Mode_En 0: disable 1:enable
27:25	/	/	/
24	R/W	0	A1 Valid in first Block
23:0	R/W	0	D23-D0 Valid in first Block

6.2.5.31. TCON0 CPU Panel Trigger5 Register (Default Value: 0x00000000)

Offset: 0x174			Register Name: TCON0_CPU_TRI5_REG
Bit	R/W	Default/Hex	Description
31:25	/	/	/
24	R/W	0	A1 Valid in Block except first
23:0	R/W	0	D23-D0 Valid in Block except first

6.2.5.32. TCON Color Map Control Register (Default Value: 0x00000000)

Offset: 0x180			Register Name: TCON0_CMAP_CTL_REG
Bit	R/W	Default/Hex	Description
31	R/W	0	Color_Map_En 0: bypass 1: enable This module only work when X is divided by 4
30:1	/	/	/
0	R/W	0	Out_Format 0: 4 pixel output mode: Out0 -> Out1 -> Out2 -> Out3 1: 2 pixel output mode: Out0 -> Out1

6.2.5.33. TCON Color Map Odd Line0 Register (Default Value: 0x00000000)

Offset: 0x190			Register Name: TCON0_CMAP_ODD0_REG
Bit	R/W	Default/Hex	Description
31:16	R/W	0	Out_Odd1
15:0	R/W	0	Out_Odd0 bit15-12: Reservd bit11-08: Out_Odd0[23:16] bit07-04: Out_Odd0[15:8] bit03-00: Out_Odd0[7:0] 0x0: in_b0 0x1: in_g0 0x2: in_r0 0x3: reservd 0x4: in_b1 0x5: in_g1 0x6: in_r1 0x7: reservd 0x8: in_b2 0x9: in_g2 0xa: in_r2 0xb: reservd 0xc: in_b3 0xd: in_g3 0xe: in_r3 0xf: reservd

6.2.5.34. TCON Color Map Odd Line1 Register (Default Value: 0x00000000)

Offset: 0x194			Register Name: TCON0_CMAP_ODD1_REG
Bit	R/W	Default/Hex	Description
31:16	R/W	0	Out_Odd3
15:0	R/W	0	Out_Odd2

6.2.5.35. TCON Color Map Even0 Register (Default Value: 0x00000000)

Offset: 0x198			Register Name: TCON0_CMAP_EVEN0_REG
Bit	R/W	Default/Hex	Description
31:16	R/W	0	Out_Even1

15:0	R/W	0	Out_Even0
------	-----	---	-----------

6.2.5.36. TCON Color Map Even1 Register (Default Value: 0x00000000)

Offset: 0x19C			Register Name: TCON_CMAP_EVEN1_REG
Bit	R/W	Default/Hex	Description
31:16	R/W	0	Out_Even3
15:0	R/W	0	Out_Even2

6.2.5.37. TCON Safe Period Register (Default Value: 0x00000000)

Offset: 0x1F0			Register Name: TCON_SAFE_PERIOD_REG
Bit	R/W	Default/Hex	Description
31:29	/	/	/
28:16	R/W	0	Safe_Period_FIFO_Num
15:4	R/W	0	Safe_Period_Line
3	/	/	/
2:0	R/W	0	Safe_Period_Mode 0: unsafe 1: safe 2: safe at ecc_fifo_curr_num > safe_period_fifo_num 3: safe at 2 and safe at sync active 4: safe at line

6.2.5.38. TCON0 LVDS ANA0 Register (Default Value: 0x00000000)

Offset: 0x220			Register Name: TCON0_LVDS_ANA0_REG
Bit	R/W	Default/Hex	Description
31	R/W	0	lvds0_en_mb enable the bias circuit of the LVDS_Ana module
30	R/W	0	lvds0_en_ldo
29:25	/	/	/
24	R/W	0	lvds0_en_drvc enable all circuits working when transmitting the data in channel clock of LVDS_tx0
23:20	R/W	0	lvds0_en_drv enable all circuits working when transmitting the data in channel<3:0> of LVDS_tx0
19	R/W	0	Lvds0_reg_dram_test 0:dram test clk disable

			1:dram test clk enable
18:17	R/W	0	lvds0_reg_c adjust current flowing through Rload of Rx to change the differential signals amplitude 0:250mV 1:300mV 2:350mV 3:400mV
16	R/W	0	lvds0_reg_denc choose data output or PLL test clock output in LVDS_tx
15:12	R/W	0	lvds0_reg_den choose data output or PLL test clock output in LVDS_tx
11:10	/	/	/
9:8	R/W	0	lvds0_reg_v adjust common mode voltage of the differential signals in five channels single signal high level: 0:1.1V 1:1.19V 2:1.3V 3:1.43V
7:6	/	/	/
5:4	R/W	0	lvds0_reg_pd fine adjust the slew rate of output data
3:2	/	/	/
1	R/W	0	lvds0_reg_pwslv adjust voltage amplitude of low power in LVDS_Ana
0	R/W	0	lvds0_reg_pwsmb adjust voltage amplitude of mbias voltage reference in LVDS_Ana

6.2.6. TCON1 Module Register List

Module Name	Base Address
TCON1	0x01C0D000

Register Name	Offset	Description
TCON_GCTL_REG	0x000	TCON global control register
TCON_GINT0_REG	0x004	TCON global interrupt register0
TCON_GINT1_REG	0x008	TCON global interrupt register1
TCON1_CTL_REG	0x090	TCON1 control register
TCON1_BASIC0_REG	0x094	TCON1 basic timing register0
TCON1_BASIC1_REG	0x098	TCON1 basic timing register1
TCON1_BASIC2_REG	0x09C	TCON1 basic timing register2
TCON1_BASIC3_REG	0x0A0	TCON1 basic timing register3
TCON1_BASIC4_REG	0x0A4	TCON1 basic timing register4
TCON1_BASIC5_REG	0x0A8	TCON1 basic timing register5
TCON1_PS_SYNC_REG	0x0B0	TCON1 sync register

TCON1_IO_POL_REG	0x0F0	TCON1 IO polarity register
TCON1_IO_TRI_REG	0x0F4	TCON1 IO trigger register
TCON_CEU_CTL_REG	0x100	TCON CEU control register
TCON_CEU_COEF_MUL_REG	0x110+N*0x04	TCON CEU coefficient register0 (N=0,1,2,4,5,6,8,9,10)
TCON_CEU_COEF_ADD_REG	0x11C+N*0x10	TCON CEU coefficient register1 (N=0,1,2)
TCON_CEU_COEF_RANG_REG	0x140+N*0x04	TCON CEU coefficient register2 (N=0,1,2)
TCON_SAFE_PERIOD_REG	0x1F0	TCON safe period register
TCON1_FILL_CTL_REG	0x300	TCON1 fill data control register
TCON1_FILL_BEGIN_REG	0x304+N*0x0C	TCON1 fill data begin register (N=0,1,2)
TCON1_FILL_END_REG	0x308+N*0x0C	TCON1 fill data end register (N=0,1,2)
TCON1_FILL_DATA0_REG	0x30C+N*0x0C	TCON1 fill data value register (N=0,1,2)
TCON1_GAMMA_TABLE_REG	0x400-0x7FF	
TCON_ECC_FIFO_BIST_REG	0xFFC	

6.2.7. TCON1 Module Register Description

6.2.7.1. TCON Global Control Register (Default Value: 0x00000000)

Offset: 0x0000			Register Name: TCON_GCTL_REG
Bit	R/W	Default/Hex	Description
31	R/W	0	TCON_En 0: disable 1: enable When it's disabled, the module will be reset to idle state.
30	R/W	0	TCON_Gamma_En 0: disable 1: enable
29:0	/	/	/

6.2.7.2. TCON Global Interrupt Register0 (Default Value: 0x00000000)

Offset: 0x0004			Register Name: TCON_GINT0_REG
Bit	R/W	Default/Hex	Description

31	/	/	/
30	R/W	0	TCON1_Vb_Int_En 0: disable 1: enable
29	/	/	/
28	R/W	0	TCON1_Line_Int_En 0: disable 1: enable
27:15	/	/	/
14	R/W	0	TCON1_Vb_Int_Flag Asserted during vertical no-display period every frame. Write 0 to clear it.
13	/	/	/
12	R/W	0	TCON1_Line_Int_Flag trigger when SY1 match the current TCON1 scan line Write 0 to clear it.
11:0	/	0	/

6.2.7.3. TCON Global Interrupt Register1 (Default Value: 0x00000000)

Offset: 0x0008			Register Name: TCON_GINT1_REG
Bit	R/W	Default/Hex	Description
31:12	/	/	/
11:0	R/W	0	TCON1_Line_Int_Num scan line for TCON1 line trigger(including inactive lines) Setting it for the specified line for trigger 1. Note: SY1 is writable only when LINE_TRG1 disable.

6.2.7.4. TCON1 Control Register (Default Value: 0x00000000)

Offset: 0x0090			Register Name: TCON1_CTL_REG
Bit	R/W	Default/Hex	Description
31	R/W	0	TCON1_En 0: disable 1: enable
30:9	/	/	/
8:4	R/W	0	Start_Delay This is for DE1 and DE2
3:2	/	/	/
1	R/W	0	TCON1_Src_Sel 00: reserved

			01: BLUE data(FIFO2 disable,RGB = 0000FF)
0	/	/	/

6.2.7.5. TCON1 Basic Timing 0 Register (Default Value: 0x00000000)

Offset: 0x0094			Register Name: TCON1_BASIC0_REG
Bit	R/W	Default/Hex	Description
31:28	/	/	/
27:16	R/W	0	TCON1_XI source width is X+1
15:12	/	/	/
11:0	R/W	0	TCON1_YI source height is Y+1

6.2.7.6. TCON1 Basic Timing 1 Register (Default Value: 0x00000000)

Offset: 0x0098			Register Name: TCON1_BASIC1_REG
Bit	R/W	Default/Hex	Description
31:28	/	/	/
27:16	R/W	0	LS_XO width is LS_XO+1
15:12	/	/	/
11:0	R/W	0	LS_YO width is LS_YO+1 NOTE: this version LS_YO = TCON1_YI

6.2.7.7. TCON1 Basic Timing 2 Register (Default Value: 0x00000000)

Offset: 0x009C			Register Name: TCON1_BASIC2_REG
Bit	R/W	Default/Hex	Description
31:28	/	/	/
27:16	R/W	0	TCON1_XO width is TCON1_XO+1
15:12	/	/	/
11:0	R/W	0	TCON1_YO height is TCON1_YO+1

6.2.7.8. TCON1 Basic Timing 3 Register (Default Value: 0x00000000)

Offset: 0x00A0			Register Name: TCON1_BASIC3_REG
Bit	R/W	Default/Hex	Description
31:29	/	/	/
28:16	R/W	0	HT horizontal total time $T_{hcycle} = (HT+1) * Thdclk$
15:12	/	/	/
11:0	R/W	0	HBP horizontal back porch $T_{hbp} = (HBP +1) * Thdclk$

6.2.7.9. TCON1 Basic Timing Register (Default Value: 0x00000000)

Offset: 0x00A4			Register Name: TCON1_BASIC4_REG
Bit	R/W	Default/Hex	Description
31:29	/	/	/
28:16	R/W	0	VT horizontal total time (in HD line) $T_{vt} = VT/2 * Th$
15:12	/	/	/
11:0	R/W	0	VBP horizontal back porch (in HD line) $T_{vbp} = (VBP +1) * Th$

6.2.7.10. TCON1 Basic Timing 5 Register (Default Value: 0x00000000)

Offset: 0x00A8			Register Name: TCON1_BASIC5_REG
Bit	R/W	Default/Hex	Description
31:29	/	/	/
25:16	R/W	0	HSPW horizontal Sync Pulse Width (in dclk) $T_{hspw} = (HSPW+1) * Tdclk$ Note: $HT > (HSPW+1)$
15:10	/	/	/
9:0	R/W	0	VSPW vertical Sync Pulse Width (in lines) $T_{vspw} = (VSPW+1) * Th$ Note: $VT/2 > (VSPW+1)$

6.2.7.11. TCON1 PS SYNC Register (Default Value: 0x00000000)

Offset: 0x00B0			Register Name: TCON1_PS_SYNC_REG
Bit	R/W	Default/Hex	Description
31:16	R/W	0	SYNC_X
15:0	R/W	0	SYNC_Y

6.2.7.12. TCON1 IO Polarity Register (Default Value: 0x00000000)

Offset: 0x00F0			Register Name: TCON1_IO_POL_REG
Bit	R/W	Default/Hex	Description
31:28	/	/	/
27	R/W	0	IO3_Inv 0: not invert 1: invert
26	R/W	0	IO2_Inv 0: not invert 1: invert
25	R/W	0	IO1_Inv 0: not invert 1: invert
24	R/W	0	IO0_Inv 0: not invert 1: invert
23:0	R/W	0	Data_Inv TCON1 output port D[23:0] polarity control, with independent bit control: 0s: normal polarity 1s: invert the specify output

6.2.7.13. TCON1 IO Polarity Register (Default Value: 0x0FFFFFFF)

Offset: 0x00F4			Register Name: TCON1_IO_POL_REG
Bit	R/W	Default/Hex	Description
31:28	/	/	/
27	R/W	1	IO3_Output_Tri_En 1: disable 0: enable
26	R/W	1	IO2_Output_Tri_En 1: disable 0: enable

25	R/W	1	IO1_Output_Tri_En 1: disable 0: enable
24	R/W	1	IO0_Output_Tri_En 1: disable 0: enable
23:0	R/W	0xFFFFFFFF	Data_Output_Tri_En TCON1 output port D[23:0] output enable, with independent bit control: 1s: disable 0s: enable

6.2.7.14. TCON CEU Control Register (Default Value: 0x00000000)

Offset: 0x0100			Register Name: TCON_CEU_CTL_REG
Bit	R/W	Default/Hex	Description
31	R/W	0	CEU_en 0: bypass 1: enable
30:0	/	/	/

6.2.7.15. TCON CEU Coefficient Mul Register (Default Value: 0x00000000)

Offset: 0x0110+N*0x04 (N=0,1,2,4,5,6,8,9,10)			Register Name: TCON_CEU_COEF_MUL_REG
Bit	R/W	Default/Hex	Description
31:13	/	/	/
12:0	R/W	0	CEU_Coef_Mul_Value signed 13bit value, range of (-16,16) N=0: Rr N=1: Rg N=2: Rb N=4: Gr N=5: Gg N=6: Gb N=8: Br N=9: Bg N=10: Bb

6.2.7.16. TCON CEU Coefficient Add Register (Default Value: 0x00000000)

Offset: 0x011C+N*0x10 (N=0,1,2)			Register Name: TCON_CEU_COEF_ADD_REG
Bit	R/W	Default/Hex	Description
31:19	/	/	/
18:0	R/W	0	CEU_Coef_Add_Value signed 19bit value, range of (-16384, 16384) N=0: Rc N=1: Gc N=2: Bc

6.2.7.17. TCON CEU Coefficient Rang Register (Default Value: 0x00000000)

Offset: 0x0140+N*0x4 (N=0,1,2)			Register Name: TCON_CEU_COEF_RANG_REG
Bit	R/W	Default/Hex	Description
31:24	/	/	/
23:16	R/W	0	CEU_Coef_Range_Min unsigned 8bit value, range of [0,255]
15:8	/	/	/
7:0	R/W	0	CEU_Coef_Range_Max unsigned 8bit value, range of [0,255]

6.2.7.18. TCON Safe Period Register (Default Value: 0x00000000)

Offset: 0x01F0			Register Name: TCON_SAFE_PERIOD_REG
Bit	R/W	Default/Hex	Description
31:29	/	/	/
28:16	R/W	0	Safe_Period_FIFO_Num
15:4	R/W	0	Safe_Period_Line
3	/	/	/
2:0	R/W	0	Safe_Period_Mode 0: unsafe 1: safe 2: safe at ecc_fifo_curr_num > safe_period_fifo_num 3: safe at 2 and safe at sync active 4: safe at line

6.2.7.19. TCON1 Fill Control Register (Default Value: 0x00000000)

Offset: 0x0300			Register Name: TCON1_FILL_CTL_REG
Bit	R/W	Default/Hex	Description
31	R/W	0	TCON1_Fill_En 0: bypass 1: enable
30:0	/	/	/

6.2.7.20. TCON1 Fill Begin Register (Default Value: 0x00000000)

Offset: 0x0304+N*0x0C(N=0,1,2)			Register Name: TCON1_FILL_BEGIN_REG
Bit	R/W	Default/Hex	Description
31:24	/	/	/
23:0	R/W	0	Fill_Begin

6.2.7.21. TCON1 Fill End Register (Default Value: 0x00000000)

Offset: 0x0308+N*0x0C(N=0,1,2)			Register Name: TCON1_FILL_END_REG
Bit	R/W	Default/Hex	Description
31:24	/	/	/
23:0	R/W	0	Fill_End

6.2.7.22. TCON1 Fill Data Register (Default Value: 0x00000000)

Offset: 0x030C+N*0x0C(N=0,1,2)			Register Name: TCON1_FILL_DATA_REG
Bit	R/W	Default/Hex	Description
31:24	/	/	/
23:0	R/W	0	Fill_Value

Chapter 7 Interfaces

This chapter describes the A64 interfaces, including:

- TWI
- SPI
- UART
- CIR Receiver
- USB
- I2S/PCM
- OWA
- SCR
- EMAC
- TSC

7.1. TWI

7.1.1. Overview

This TWI Controller is designed to be used as an interface between CPU host and the serial TWI bus. It can support all the standard TWI transfer, including Slave and Master. The communication to the TWI bus is carried out on a byte-wise basis using interrupt or polled handshaking. This TWI Controller can be operated in standard mode (100K bps) or fast-mode, supporting data rate up to 400K bps. Multiple Masters and 10-bit addressing Mode are supported for this specified application. General Call Addressing is also supported in Slave mode.

The TWI Controller includes the following features:

- Software-programmable for Slave or Master
- Support Repeated START signal
- Multi-master systems supported
- Allow 10-bit addressing with TWI bus
- Performs arbitration and clock synchronization
- Own address and General Call address detection
- Interrupt on address detection
- Support speeds up to 400Kbits/s ('fast mode')
- Allow operation from a wide range of input clock frequencies

7.1.2. Timing Diagram

Data transferred are always in a unit of 8-bit (byte), followed by an acknowledge bit. The number of bytes that can be transmitted per transfer is unrestricted. Data is transferred in serial with the MSB first. Between each byte of data transfer, a receiver device will hold the clock line SCL low to force the transmitter into a wait state while waiting the response from microprocessor.

Data transfer with acknowledge is obligatory. The clock line is driven by the master all the time, including the acknowledge-related clock cycle, except for the SCL holding between each bytes. After sending each byte, the transmitter releases the SDA line to allow the receiver to pull down the SDA line and send an acknowledge signal (or leave it high to send a "not acknowledge") to the transmitter.

When a slave receiver doesn't acknowledge the slave address (unable to receive because of no resource available), the data line must be left high by the slave so that the master can then generate a STOP condition to abort the transfer. Slave receiver can also indicate not to want to send more data during a transfer by leave the acknowledge signal high. And the master should generate the STOP condition to abort the transfer.

Below diagram provides an illustration the relation of SDA signal line and SCL signal line on the TWI serial bus.

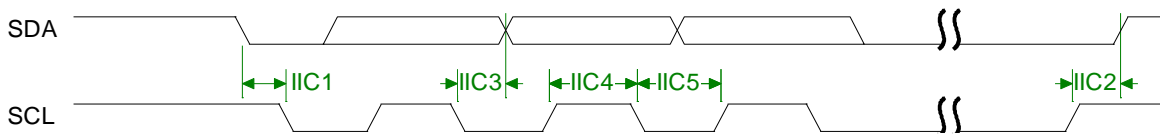

Figure 7-1. TWI Timing Diagram

7.1.3. TWI Controller Special Requirement

7.1.3.1. TWI Pin List

Port Name	Width	Direction	Description
TWI_SCL	1	IN/OUT	TWI Clock line
TWI_SDA	1	IN/OUT	TWI Serial Data line

7.1.3.2. TWI Controller Operation

There are four operation modes on the TWI bus which dictates the communications method. They are Master Transmit, Master Receive, Slave Transmit and Slave Receive. In general, CPU host controls TWI by writing commands and data to its registers. The TWI interrupts the CPU host for the attention each time a byte transfer is done or a START/STOP conditions is detected. The CPU host can also poll the status register for current status if the interrupt mechanism is not disabled by the CPU host.

When the CPU host wants to start a bus transfer, it initiates a bus START to enter the master mode by setting IM_STA bit in the 2WIRE_CNTR register to high (before it must be low). The TWI will assert INT line and INT_FLAG to indicate a completion for the START condition and each consequent byte transfer. At each interrupt, the micro-processor needs to check the 2WIRE_STAT register for current status. A transfer has to be concluded with STOP condition by setting M_STP bit high.

In Slave Mode, the TWI also constantly samples the bus and look for its own slave address during addressing cycles. Once a match is found, it is addressed and interrupted the CPU host with the corresponding status. Upon request, the CPU host should read the status, read/write 2WIRE_DATA data register, and set the 2WIRE_CNTR control register. After each byte transfer, a slave device always halt the operation of remote master by holding the next low pulse on SCL line until the microprocessor responds to the status of previous byte transfer or START condition.

7.1.4. TWI Controller Register List

Module Name	Base Address
R_TWI	0x01F02400
TWI0	0x01C2AC00
TWI1	0x01C2B000
TWI2	0x01C2B400

Register Name	Offset	Description
TWI_ADDR	0x0000	TWI Slave address
TWI_XADDR	0x0004	TWI Extended slave address
TWI_DATA	0x0008	TWI Data byte
TWI_CNTR	0x000C	TWI Control register
TWI_STAT	0x0010	TWI Status register
TWI_CCR	0x0014	TWI Clock control register
TWI_SRST	0x0018	TWI Software reset
TWI_EFR	0x001C	TWI Enhance Feature register
TWI_LCR	0x0020	TWI Line Control register

7.1.5. TWI Controller Register Description

7.1.5.1. TWI Slave Address Register(Default Value: 0x00000000)

Offset: 0x00			Register Name: TWI_ADDR
Bit	R/W	Default/Hex	Description
31:8	/	/	/
7:1	R/W	0	SLA Slave address <ul style="list-style-type: none"> 7-bit addressing SLA6, SLA5, SLA4, SLA3, SLA2, SLA1, SLA0 10-bit addressing 1, 1, 1, 1, 0, SLAX[9:8]
0	R/W	0	GCE General call address enable 0: Disable 1: Enable

Notes:

For 7-bit addressing:

SLA6 – SLA0 is the 7-bit address of the TWI when in slave mode. When the TWI receives this address after a START condition, it will generate an interrupt and enter slave mode. (SLA6 corresponds to the first bit received

from the TWI bus.) If GCE is set to '1', the TWI will also recognize the general call address (00h).

For 10-bit addressing:

When the address received starts with 11110b, the TWI recognizes this as the first part of a 10-bit address and if the next two bits match ADDR[2:1] (i.e. SLAX9 and SLAX8 of the device's extended address), it sends an ACK. (The device does not generate an interrupt at this point.) If the next byte of the address matches the XADDR register (SLAX7 – SLAX0), the TWI generates an interrupt and goes into slave mode.

7.1.5.2. TWI Extend Address Register(Default Value: 0x00000000)

Offset: 0x04			Register Name: TWI_XADDR
Bit	R/W	Default/Hex	Description
31:8	/	/	/
7:0	R/W	0	SLAX Extend Slave Address SLAX[7:0]

7.1.5.3. TWI Data Register(Default Value: 0x00000000)

Offset: 0x08			Register Name: TWI_DATA
Bit	R/W	Default/Hex	Description
31:8	/	/	/
7:0	R/W	0	TWI_DATA Data byte for transmitting or received

7.1.5.4. TWI Control Register(Default Value: 0x00000000)

Offset: 0x0C			Register Name: TWI_CNTR
Bit	R/W	Default/Hex	Description
31:8	/	/	/
7	R/W	0	INT_EN Interrupt Enable 1'b0: The interrupt line always low 1'b1: The interrupt line will go high when INT_FLAG is set.
6	R/W	0	BUS_EN TWI Bus Enable 1'b0: The TWI bus inputs ISDA/ISCL are ignored and the TWI Controller will not respond to any address on the bus 1'b1: The TWI will respond to calls to its slave address – and to the

			<p>general call address if the GCE bit in the ADDR register is set.</p> <p>Notes: In master operation mode, this bit should be set to '1'</p>
5	R/W	0	<p>M_STA Master Mode Start</p> <p>When M_STA is set to '1', TWI Controller enters master mode and will transmit a START condition on the bus when the bus is free. If the M_STA bit is set to '1' when the TWI Controller is already in master mode and one or more bytes have been transmitted, then a repeated START condition will be sent. If the M_STA bit is set to '1' when the TWI is being accessed in slave mode, the TWI will complete the data transfer in slave mode then enter master mode when the bus has been released.</p> <p>The M_STA bit is cleared automatically after a START condition has been sent, writing a '0' to this bit has no effect.</p>
4	R/W	0	<p>M_STP Master Mode Stop</p> <p>If M_STP is set to '1' in master mode, a STOP condition is transmitted on the TWI bus. If the M_STP bit is set to '1' in slave mode, the TWI will behave as if a STOP condition has been received, but no STOP condition will be transmitted on the TWI bus. If both M_STA and M_STP bits are set, the TWI will first transmit the STOP condition (if in master mode) then transmit the START condition.</p> <p>The M_STP bit is cleared automatically, writing a '0' to this bit has no effect.</p>
3	R/W	0	<p>INT_FLAG Interrupt Flag</p> <p>INT_FLAG is automatically set to '1' when any of 28 (out of the possible 29) states is entered (see 'STAT Register' below). The only state that does not set INT_FLAG is state F8h. If the INT_EN bit is set, the interrupt line goes high when IFLG is set to '1'. If the TWI is operating in slave mode, data transfer is suspended when INT_FLAG is set and the low period of the TWI bus clock line (SCL) is stretched until '1' is written to INT_FLAG. The TWI clock line is then released and the interrupt line goes low.</p>
2	R/W	0	<p>A_ACK Assert Acknowledge</p> <p>When A_ACK is set to '1', an Acknowledge (low level on SDA) will be sent during the acknowledge clock pulse on the TWI bus if:</p> <ol style="list-style-type: none"> 1. Either the whole of a matching 7-bit slave address or the first or the second byte of a matching 10-bit slave address has been received. 2. The general call address has been received and the GCE bit in the ADDR register is set to '1'. 3. A data byte has been received in master or slave mode. <p>When A_ACK is '0', a Not Acknowledge (high level on SDA) will be sent when a data byte is received in master or slave mode.</p> <p>If A_ACK is cleared to '0' in slave transmitter mode, the byte in the DATA</p>

			register is assumed to be the 'last byte'. After this byte has been transmitted, the TWI will enter state C8h then return to the idle state (status code F8h) when INT_FLAG is cleared. The TWI will not respond as a slave unless A_ACK is set.
1:0	R/W	0	/

7.1.5.5. TWI Status Register(Default Value: 0x00000F8)

Offset: 0x10			Register Name: TWI_STAT
Bit	R/W	Default/Hex	Description
31:8	/	/	/
7:0	R	0xF8	STA Status Information Byte Code Status 0x00: Bus error 0x08: START condition transmitted 0x10: Repeated START condition transmitted 0x18: Address + Write bit transmitted, ACK received 0x20: Address + Write bit transmitted, ACK not received 0x28: Data byte transmitted in master mode, ACK received 0x30: Data byte transmitted in master mode, ACK not received 0x38: Arbitration lost in address or data byte 0x40: Address + Read bit transmitted, ACK received 0x48: Address + Read bit transmitted, ACK not received 0x50: Data byte received in master mode, ACK transmitted 0x58: Data byte received in master mode, not ACK transmitted 0x60: Slave address + Write bit received, ACK transmitted 0x68: Arbitration lost in address as master, slave address + Write bit received, ACK transmitted 0x70: General Call address received, ACK transmitted 0x78: Arbitration lost in address as master, General Call address received, ACK transmitted 0x80: Data byte received after slave address received, ACK transmitted 0x88: Data byte received after slave address received, not ACK transmitted 0x90: Data byte received after General Call received, ACK transmitted 0x98: Data byte received after General Call received, not ACK transmitted 0xA0: STOP or repeated START condition received in slave mode 0xA8: Slave address + Read bit received, ACK transmitted 0xB0: Arbitration lost in address as master, slave address + Read bit received, ACK transmitted 0xB8: Data byte transmitted in slave mode, ACK received 0xC0: Data byte transmitted in slave mode, ACK not received

			<p>0xC8: Last byte transmitted in slave mode, ACK received</p> <p>0xD0: Second Address byte + Write bit transmitted, ACK received</p> <p>0xD8: Second Address byte + Write bit transmitted, ACK not received</p> <p>0xF8: No relevant status information, INT_FLAG=0</p> <p>Others: Reserved</p>
--	--	--	--

7.1.5.6. TWI Clock Register(Default Value: 0x00000000)

Offset: 0x14			Register Name: TWI_CCR
Bit	R/W	Default/Hex	Description
31:7	/	/	/
6:3	R/W	0	CLK_M
2:0	R/W	0	<p>CLK_N</p> <p>The TWI bus is sampled by the TWI at the frequency defined by F0: $F_{\text{samp}} = F_0 = F_{\text{in}} / 2^{\text{CLK_N}}$</p> <p>The TWI OSCL output frequency, in master mode, is F1 / 10: $F_1 = F_0 / (\text{CLK_M} + 1)$ $F_{\text{oscl}} = F_1 / 10 = F_{\text{in}} / (2^{\text{CLK_N}} * (\text{CLK_M} + 1) * 10)$</p> <p>For Example: $F_{\text{in}} = 48\text{Mhz}$ (APB clock input) For 400kHz full speed 2Wire, CLK_N = 2, CLK_M=2 $F_0 = 48\text{M} / 2^2 = 12\text{Mhz}$, $F_1 = F_0 / (10 * (2+1)) = 0.4\text{Mhz}$ For 100Khz standard speed 2Wire, CLK_N=2, CLK_M=11 $F_0 = 48\text{M} / 2^2 = 12\text{Mhz}$, $F_1 = F_0 / (10 * (11+1)) = 0.1\text{Mhz}$</p>

7.1.5.7. TWI Soft Reset Register(Default Value: 0x00000000)

Offset: 0x18			Register Name: TWI_SRST
Bit	R/W	Default/Hex	Description
31:1	/	/	/
0	R/W	0	<p>SOFT_RST</p> <p>Soft Reset</p> <p>Write '1' to this bit to reset the TWI and clear to '0' when completing Soft Reset operation.</p>

7.1.5.8. TWI Enhance Feature Register(Default Value: 0x00000000)

Offset: 0x1C			Register Name: TWI_EFR
Bit	R/W	Default/Hex	Description
31:2	/	/	/

0:1	R/W	0	<p>DBN</p> <p>Data Byte number follow Read Command Control</p> <p>0— No Data Byte to be written after read command</p> <p>1— Only 1 byte data to be written after read command</p> <p>2— 2 bytes data can be written after read command</p> <p>3— 3 bytes data can be written after read command</p>
-----	-----	---	--

7.1.5.9. TWI Line Control Register(Default Value: 0x0000003A)

Offset: 0x20			Register Name: TWI_LCR
Bit	R/W	Default/Hex	Description
31:6	/	/	/
5	R	1	<p>SCL_STATE</p> <p>Current state of TWI_SCL</p> <p>0 – low</p> <p>1 - high</p>
4	R	1	<p>SDA_STATE</p> <p>Current state of TWI_SDA</p> <p>0 – low</p> <p>1 - high</p>
3	R/W	1	<p>SCL_CTL</p> <p>TWI_SCL line state control bit</p> <p>When line control mode is enabled (bit[2] set), value of this bit decide the output level of TWI_SCL</p> <p>0 – output low level</p> <p>1 – output high level</p>
2	R/W	0	<p>SCL_CTL_EN</p> <p>TWI_SCL line state control enable</p> <p>When this bit is set, the state of TWI_SCL is control by the value of bit[3].</p> <p>0-disable TWI_SCL line control mode</p> <p>1-enable TWI_SCL line control mode</p>
1	R/W	1	<p>SDA_CTL</p> <p>TWI_SDA line state control bit</p> <p>When line control mode is enabled (bit[0] set), value of this bit decide the output level of TWI_SDA</p> <p>0 – output low level</p> <p>1 – output high level</p>
0	R/W	0	<p>SDA_CTL_EN</p> <p>TWI_SDA line state control enable</p> <p>When this bit is set, the state of TWI_SDA is control by the value of bit[1].</p> <p>0-disable TWI_SDA line control mode</p> <p>1-enable TWI_SDA line control mode</p>

7.1.5.10. TWI DVFS Register(Default Value: 0x00000000)

Offset: 0x24			Register Name: TWI_DVFSR
Bit	R/W	Default/Hex	Description
31:3	/	/	/
2	R/W	0	MS_PRIORITY CPU and DVFS BUSY set priority select 0: CPU has higher priority 1: DVFS has higher priority
1	R/W	0	CPU_BUSY_SET CPU Busy set
0	R/W	0	DVFC_BUSY_SET DVFS Busy set

Notes:This register is only implemented in TWI0.

7.2. SPI

7.2.1. Overview

The SPI is the Serial Peripheral Interface which allows rapid data communication with fewer software interrupts. It can interface with up to four slave external devices or one single external master. The SPI module contains one 64x8 receiver buffer (RXFIFO) and one 64x8 transmit buffer (TXFIFO). It can work at two modes: Master mode and Slave mode.

The SPI includes the following features:

- Full-duplex synchronous serial interface
- Master/Slave configurable
- Programmable clock granularity
- Four chip selects to support multiple peripherals
- 8-bit wide by 64-entry FIFO for both transmit and receive data
- Polarity and phase of the Chip Select (SPI_SS) and SPI Clock (SPI_SCLK) are configurable
- Interrupt or DMA supported
- Support single and dual read mode

7.2.2. SPI Block Diagram

Figure 7-2 shows a block diagram of the SPI.

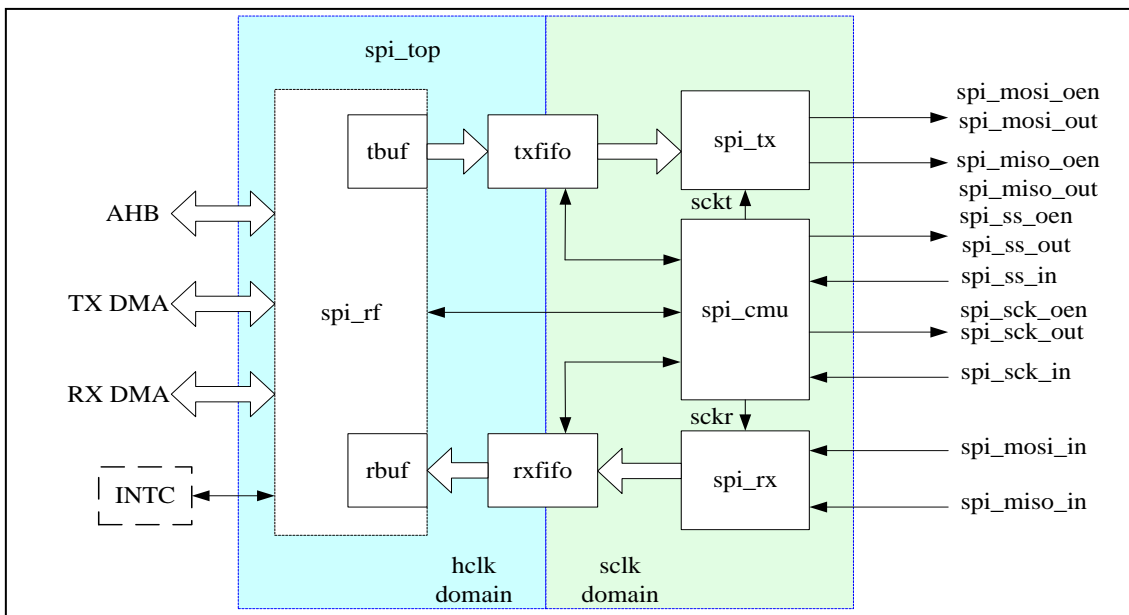

Figure 7-2. SPI Block Diagram

The SPI comprises with:

spi_rf: Responsible for implementing the internal register,interrupt and DMA Request.

spi_tbuf: The data length transmitted from AHB to txfifo is converted into 8bits,then the data is written into the rxfifo.

spi_rbuf: The block is used as converted the rxfifo data into read data length of AHB.

txfifo,rxfifo: For transmit and receive transfers,data transmitted from the SPI to the external serial device is written into the txfifo;data received from the external serial device into SPI is pushed into the rxfifo.

spi_cmu: Responsible for implementing SPI bus clock,chip select,internal sample and the generation of transfer clock.

spi_tx: Responsible for implementing SPI data transfer ,the interface of the internal txfifo and status register.

spi_rx: Responsible for implementing SPI data receive, the interface of the internal rxfifo and status register.

7.2.3. SPI Timing Diagram

The serial peripheral interface master uses the SPI_SCLK signal to transfer data in and out of the shift register. Data is clocked using any one of four programmable clock phase and polarity combinations.

During Phase 0, Polarity 0 and Phase 1, Polarity 1 operations, output data changes on the falling clock edge and input data is shifted in on the rising edge.

During Phase 1, Polarity 0 and Phase 0, Polarity 1 operations, output data changes on the rising edges of the clock and is shifted in on falling edges.

The POL defines the signal polarity when SPI_SCLK is in idle state. The SPI_SCLK is high level when POL is '1' and it is low level when POL is '0'. The PHA decides whether the leading edge of SPI_SCLK is used for setup or sample data. The leading edge is used for setup data when PHA is '1' and for sample data when PHA is '0'. The four kind of modes are listed below:

SPI Mode	POL	PHA	Leading Edge	Trailing Edge
0	0	0	Rising, Sample	Falling, Setup
1	0	1	Rising, Setup	Falling, Sample
2	1	0	Falling, Sample	Rising, Setup
3	1	1	Falling, Setup	Rising, Sample

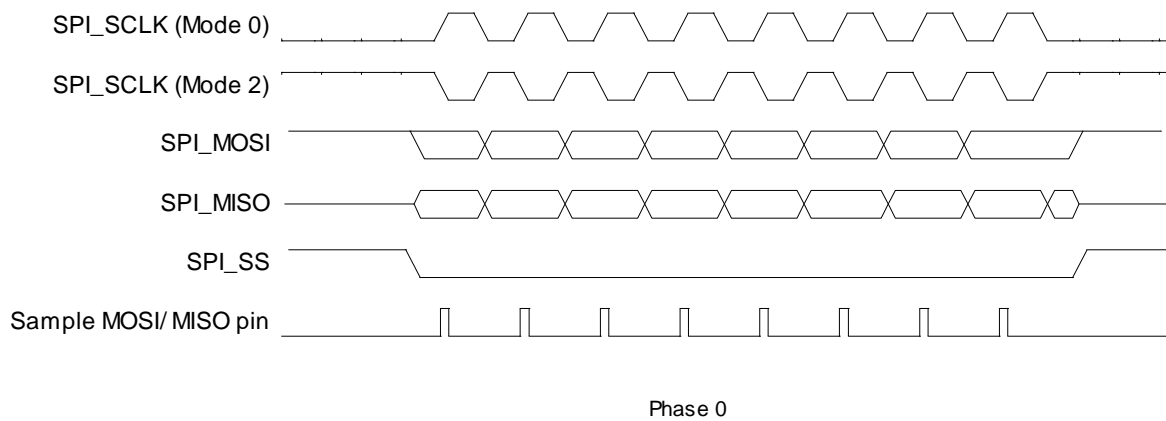

Figure 7-3. SPI Phase 0 Timing Diagram

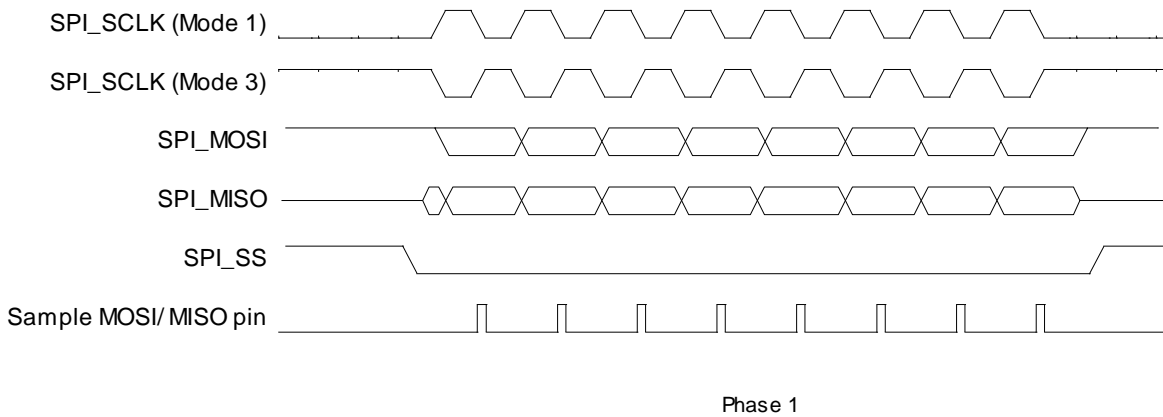

Figure 7-4. SPI Phase 1 Timing Diagram

7.2.4. SPI Pin Lists

The direction of SPI pin is different in two work modes: Master Mode and Slave Mode. The following table describes the external pins of SPI. SPI_MOSI and SPI_MISO are bidirectional I/O. When SPI is configured as Master device, CLK and CS is output pin; when SPI is configurable as Slave device, CLK and CS is input pin. The unused SPI ports are used as General Purpose I/O ports. For information about General Purpose I/O ports, see [Port Controller\(CPUx-PORT\)](#) in chapter 3.

Port Name	Width	Direction(M)	Direction(S)	Description
SPI_CLK	1	OUT	IN	SPI Clock
SPI_MOSI	1	OUT	IN	SPI Master Output Slave Input Data Signal
SPI_MISO	1	IN	OUT	SPI Master Input Slave Output Data Signal
SPI_CS	1	OUT	IN	SPI Chip Select Signal

7.2.5. SPI Register List

Module Name	Base Address
SPI0	0x01C68000
SPI1	0x01C69000

Register Name	Offset	Description
SPI_GCR	0x04	SPI Global Control Register
SPI_TCR	0x08	SPI Transfer Control register
/	0x0c	reserved
SPI_IER	0x10	SPI Interrupt Control register
SPI_ISR	0x14	SPI Interrupt Status register
SPI_FCR	0x18	SPI FIFO Control register
SPI_FSR	0x1C	SPI FIFO Status register
SPI_WCR	0x20	SPI Wait Clock Counter register
SPI_CCR	0x24	SPI Clock Rate Control register
/	0x28	reserved
/	0x2c	reserved
SPI_MBC	0x30	SPI Burst Counter register
SPI_MTC	0x34	SPI Transmit Counter Register
SPI_BCC	0x38	SPI Burst Control register
SPI_NDMA_MODE_CTL	0x88	SPI Normal DMA Mode Control Register
SPI_TXD	0x200	SPI TX Data register
SPI_RXD	0x300	SPI RX Data register

7.2.6. SPI Register Description

7.2.6.1. SPI Global Control Register(Default Value: 0x00000080)

Offset: 0x04			Register Name: SPI_CTL
Bit	R/W	Default/Hex	Description
31	R/W	0	SRST Soft reset Write '1' to this bit will clear the SPI controller, and auto clear to '0' when reset operation completes Write '0' has no effect.
30:8	/	/	/
7	R/W	1	TP_EN Transmit Pause Enable In master mode, it is used to control transmit state machine to stop smart burst sending when RX FIFO is full.

			1 – stop transmit data when RXFIFO full 0 – normal operation, ignore RXFIFO status Note: Can't be written when XCH=1
6:2	/	/	/
1	R/W	0	MODE SPI Function Mode Select 0: Slave Mode 1: Master Mode Note: Can't be written when XCH=1
0	R/W	0	EN SPI Module Enable Control 0: Disable 1: Enable

7.2.6.2. SPI Transfer Control Register(Default Value: 0x00000087)

Offset: 0x08			Register Name: SPI_INTCTL
Bit	R/W	Default/Hex	Description
31	R/W	0x0	XCH Exchange Burst In master mode it is used to start SPI burst 0: Idle 1: Initiates exchange. Write "1" to this bit will start the SPI burst, and will auto clear after finishing the bursts transfer specified by BC. Write "1" to SRST will also clear this bit. Write '0' to this bit has no effect. Note: Can't be written when XCH=1.
30:15	/	/	/
14	R/W	0x0	SDDM Sending Data Delay Mode 0:normal sending 1:delay sending Set the bit to"1" to make the data that should be sent with a delay of half cycle of SPI_CLK in dual io mode for SPI mode 0.
13	R/W	0x0	SDM Master Sample Data Mode 0 - Delay Sample Mode 1 - Normal Sample Mode In Normal Sample Mode, SPI master samples the data at the correct edge for each SPI mode; In Delay Sample Mode, SPI master samples data at the edge that is half cycle delayed by the correct edge defined in respective SPI mode.
12	R/W	0x0	FBS

			<p>First Transmit Bit Select</p> <p>0: MSB first</p> <p>1: LSB first</p> <p>Note: Can't be written when XCH=1.</p>
11	R/W	0x0	<p>SDC</p> <p>Master Sample Data Control</p> <p>Set this bit to '1' to make the internal read sample point with a delay of half cycle of SPI_CLK. It is used in high speed read operation to reduce the error caused by the time delay of SPI_CLK propagating between master and slave.</p> <p>0 – normal operation, do not delay internal read sample point</p> <p>1 – delay internal read sample point</p> <p>Note: Can't be written when XCH=1.</p>
10	R/W	0x0	<p>RPSM</p> <p>Rapids mode select</p> <p>Select Rapids mode for high speed write.</p> <p>0: normal write mode</p> <p>1: rapids write mode</p> <p>Note: Can't be written when XCH=1.</p>
9	R/W	0x0	<p>DDB</p> <p>Dummy Burst Type</p> <p>0: The bit value of dummy SPI burst is zero</p> <p>1: The bit value of dummy SPI burst is one</p> <p>Note: Can't be written when XCH=1.</p>
8	R/W	0x0	<p>DHB</p> <p>Discard Hash Burst</p> <p>In master mode it controls whether discarding unused SPI bursts</p> <p>0: Receiving all SPI bursts in BC period</p> <p>1: Discard unused SPI bursts, only fetching the SPI bursts during dummy burst period. The bursts number is specified by TC.</p> <p>Note: Can't be written when XCH=1.</p>
7	R/W	0x1	<p>SS_LEVEL</p> <p>When control SS signal manually (SPI_CTRL_REG.SS_CTRL==1), set this bit to '1' or '0' to control the level of SS signal.</p> <p>0: set SS to low</p> <p>1: set SS to high</p> <p>Note: Can't be written when XCH=1.</p>
6	R/W	0x0	<p>SS_OWNER</p> <p>SS Output Owner Select</p> <p>Usually, controller sends SS signal automatically with data together. When this bit is set to 1, software must manually write SPI_CTL_REG.SS_LEVEL to 1 or 0 to control the level of SS signal.</p> <p>0: SPI controller</p> <p>1: Software</p>

			Note: Can't be written when XCH=1.
5:4	R/W	0x0	<p>SS_SEL SPI Chip Select Select one of four external SPI Master/Slave Devices 00: SPI_SS0 will be asserted 01: SPI_SS1 will be asserted 10: SPI_SS2 will be asserted 11: SPI_SS3 will be asserted Note: Can't be written when XCH=1.</p>
3	R/W	0x0	<p>SSCTL In master mode, this bit selects the output wave form for the SPI_SSx signal. Only valid when SS_OWNER = 0. 0: SPI_SSx remains asserted between SPI bursts 1: Negate SPI_SSx between SPI bursts Note: Can't be written when XCH=1.</p>
2	R/W	0x1	<p>SPOL SPI Chip Select Signal Polarity Control 0: Active high polarity (0 = Idle) 1: Active low polarity (1 = Idle) Note: Can't be written when XCH=1.</p>
1	R/W	0x1	<p>CPOL SPI Clock Polarity Control 0: Active high polarity (0 = Idle) 1: Active low polarity (1 = Idle) Note: Can't be written when XCH=1.</p>
0	R/W	0x1	<p>CPHA SPI Clock/Data Phase Control 0: Phase 0 (Leading edge for sample data) 1: Phase 1 (Leading edge for setup data) Note: Can't be written when XCH=1.</p>

7.2.6.3. SPI Interrupt Control Register(Default Value: 0x00000000)

Offset: 0x10			Register Name: SPI_IER
Bit	R/W	Default/Hex	Description
31:14	R	0x0	Reserved.
13	R/W	0x0	<p>SS_INT_EN SSI Interrupt Enable Chip Select Signal (SSx) from valid state to invalid state 0: Disable 1: Enable</p>
12	R/W	0x0	<p>TC_INT_EN Transfer Completed Interrupt Enable</p>

			0: Disable 1: Enable
11	R/W	0x0	TF_UDR_INT_EN TXFIFO under run Interrupt Enable 0: Disable 1: Enable
10	R/W	0x0	TF_OVF_INT_EN TX FIFO Overflow Interrupt Enable 0: Disable 1: Enable
9	R/W	0x0	RF_UDR_INT_EN RXFIFO under run Interrupt Enable 0: Disable 1: Enable
8	R/W	0x0	RF_OVF_INT_EN RX FIFO Overflow Interrupt Enable 0: Disable 1: Enable
7	R	0x0	Reserved.
6	R/W	0x0	TF_FUL_INT_EN TX FIFO Full Interrupt Enable 0: Disable 1: Enable
5	R/W	0x0	TX_EMP_INT_EN TX FIFO Empty Interrupt Enable 0: Disable 1: Enable
4	R/W	0x0	TX_ERQ_INT_EN TX FIFO Empty Request Interrupt Enable 0: Disable 1: Enable
3	R	0x0	Reserved
2	R/W	0x0	RF_FUL_INT_EN RX FIFO Full Interrupt Enable 0: Disable 1: Enable
1	R/W	0x0	RX_EMP_INT_EN RX FIFO Empty Interrupt Enable 0: Disable 1: Enable
0	R/W	0x0	RF_RDY_INT_EN RX FIFO Ready Request Interrupt Enable 0: Disable 1: Enable

7.2.6.4. SPI Interrupt Status Register(Default Value: 0x0000022)

Offset: 0x14			Register Name: SPI_INT_STA
Bit	R/W	Default/Hex	Description
31:14	/	0x0	/
13	R/W	0	SSI SS Invalid Interrupt When SSI is 1, it indicates that SS has changed from valid state to invalid state. Writing 1 to this bit clears it.
12	R/W	0	TC Transfer Completed In master mode, it indicates that all bursts specified by BC has been exchanged. In other condition, When set, this bit indicates that all the data in TXFIFO has been loaded in the Shift register, and the Shift register has shifted out all the bits. Writing 1 to this bit clears it. 0: Busy 1: Transfer Completed
11	R/W	0	TF_UDF TXFIFO Underrun This bit is set when if the TXFIFO is underrun. Writing 1 to this bit clears it. 0: TXFIFO is not underrun 1: TXFIFO is underrun
10	R/W	0	TF_OVF TXFIFO Overflow This bit is set when if the TXFIFO is overflow. Writing 1 to this bit clears it. 0: TXFIFO is not overflow 1: TXFIFO is overflowed
9	R/W	0	RX_UDF RXFIFO Underrun When set, this bit indicates that RXFIFO has underrun. Writing 1 to this bit clears it.
8	R/W	0	RX_OVF RXFIFO Overflow When set, this bit indicates that RXFIFO has overflowed. Writing 1 to this bit clears it. 0: RXFIFO is available. 1: RXFIFO has overflowed.
7	/	/	/
6	R/W	0	TX_FULL TXFIFO Full This bit is set when if the TXFIFO is full . Writing 1 to this bit clears it.

			0: TXFIFO is not Full 1: TXFIFO is Full
5	R/W	1	TX_EMP TXFIFO Empty This bit is set if the TXFIFO is empty. Writing 1 to this bit clears it. 0: TXFIFO contains one or more words. 1: TXFIFO is empty
4	R/W	0	TX_READY TXFIFO Ready 0: TX_WL > TX_TRIG_LEVEL 1: TX_WL <= TX_TRIG_LEVEL This bit is set any time if TX_WL <= TX_TRIG_LEVEL. Writing "1" to this bit clears it. Where TX_WL is the water level of RXFIFO
3	/	/	reserved
2	R/W	0	RX_FULL RXFIFO Full This bit is set when the RXFIFO is full . Writing 1 to this bit clears it. 0: Not Full 1: Full
1	R/W	1	RX_EMP RXFIFO Empty This bit is set when the RXFIFO is empty . Writing 1 to this bit clears it. 0: Not empty 1: empty
0	R/W	0	RX_RDY RXFIFO Ready 0: RX_WL < RX_TRIG_LEVEL 1: RX_WL >= RX_TRIG_LEVEL This bit is set any time if RX_WL >= RX_TRIG_LEVEL. Writing "1" to this bit clears it. Where RX_WL is the water level of RXFIFO.

7.2.6.5. SPI FIFO Control Register(Default Value: 0x00400001)

Offset: 0x18			Register Name: SPI_FCR
Bit	R/W	Default/Hex	Description
31	R/W	0	TX_FIFO_RST TX FIFO Reset Write '1' to this bit will reset the control portion of the TX FIFO and auto clear to '0' when completing reset operation, write to '0' has no effect.
30	R/W	0	TF_TEST_ENB TX Test Mode Enable 0: disable 1: enable

			Note: In normal mode, TX FIFO can only be read by SPI controller, write '1' to this bit will switch TX FIFO read and write function to AHB bus. This bit is used to test the TX FIFO, don't set in normal operation and don't set RF_TEST and TF_TEST at the same time.
29:26	/	/	/
25	/	/	/
24	R/W	0x0	TF_DRQ_EN TX FIFO DMA Request Enable 0: Disable 1: Enable
23:16	R/W	0x40	TX_TRIG_LEVEL TX FIFO Empty Request Trigger Level
15	R/W	0x0	RF_RST RXFIFO Reset Write '1' to this bit will reset the control portion of the receiver FIFO, and auto clear to '0' when completing reset operation, write '0' to this bit has no effect.
14	R/W	0x0	RF_TEST RX Test Mode Enable 0: Disable 1: Enable Note: In normal mode, RX FIFO can only be written by SPI controller, write '1' to this bit will switch RX FIFO read and write function to AHB bus. This bit is used to test the RX FIFO, don't set in normal operation and don't set RF_TEST and TF_TEST at the same time.
13:10	R	0x0	Reserved
9	R/W	0x0	RX_DMA_MODE SPI RX DMA Mode Control 0: Normal DMA mode 1: Dedicate DMA mode
8	R/W	0x0	RF_DRQ_EN RX FIFO DMA Request Enable 0: Disable 1: Enable
7:0	R/W	0x1	RX_TRIG_LEVEL RX FIFO Ready Request Trigger Level

7.2.6.6. SPI FIFO Status Register(Default Value: 0x00000000)

Offset: 0x1C			Register Name: SPI_FSR
Bit	R/W	Default/Hex	Description
31	R	0x0	TB_WR TX FIFO Write Buffer Write Enable

30:28	R	0x0	TB_CNT TX FIFO Write Buffer Counter These bits indicate the number of words in TX FIFO Write Buffer
27:24	R	0x0	Reserved
23:16	R	0x0	TF_CNT TX FIFO Counter These bits indicate the number of words in TX FIFO 0: 0 byte in TX FIFO 1: 1 byte in TX FIFO ... 64: 64 bytes in TX FIFO
15	R	0x0	RB_WR RX FIFO Read Buffer Write Enable
14:12	R	0x0	RB_CNT RX FIFO Read Buffer Counter These bits indicate the number of words in RX FIFO Read Buffer
11:8	R	0x0	Reserved
7:0	R	0x0	RF_CNT RX FIFO Counter These bits indicate the number of words in RX FIFO 0: 0 byte in RX FIFO 1: 1 byte in RX FIFO ... 64:64 bytes in RX FIFO

7.2.6.7. SPI Wait Clock Register(Default Value: 0x00000000)

Offset: 0x20			Register Name: SPI_WAIT
Bit	R/W	Default/Hex	Description
31:20	/	/	/
19:16	R/W	0x0	SWC Dual mode direction switch wait clock counter (for master mode only). 0: No wait states inserted n: n SPI_SCLK wait states inserted Note: These bits control the number of wait states to be inserted before start dual data transfer in dual SPI mode. The SPI module counts SPI_SCLK by SWC for delaying next word data transfer. Note: Can't be written when XCH=1.
15:0	R/W	0	WCC Wait Clock Counter (In Master mode) These bits control the number of wait states to be inserted in data transfers. The SPI module counts SPI_SCLK by WCC for delaying next word data transfer.

			0: No wait states inserted N: N SPI_SCLK wait states inserted
--	--	--	--

7.2.6.8. SPI Clock Control Register(Default Value: 0x00000002)

Offset: 0x24			Register Name: SPI_CCTL
Bit	R/W	Default/Hex	Description
31:13	/	/	/
12	R/W	0	DRS Divide Rate Select (Master Mode Only) 0: Select Clock Divide Rate 1 1: Select Clock Divide Rate 2
11:8	R/W	0	CDR1 Clock Divide Rate 1 (Master Mode Only) The SPI_SCLK is determined according to the following equation: SPI_CLK = Source_CLK / 2^n.
7:0	R/W	0x2	CDR2 Clock Divide Rate 2 (Master Mode Only) The SPI_SCLK is determined according to the following equation: SPI_CLK = Source_CLK / (2*(n + 1)).

7.2.6.9. SPI Master Burst Counter Register(Default Value: 0x00000000)

Offset: 0x30			Register Name: SPI_BC
Bit	R/W	Default/Hex	Description
31:24	/	/	/
23:0	R/W	0	MBC Master Burst Counter In master mode, this field specifies the total burst number. 0: 0 burst 1: 1 burst ... N: N bursts

7.2.6.10. SPI Master Transmit Counter Register(Default Value: 0x00000000)

Offset: 0x34			Register Name: SPI_TC
Bit	R/W	Default/Hex	Description
31:24	/	/	/
23:0	R/W	0	MWTC

			<p>Master Write Transmit Counter</p> <p>In master mode, this field specifies the burst number that should be sent to TXFIFO before automatically sending dummy burst. For saving bus bandwidth, the dummy burst (all zero bits or all one bits) is sent by SPI Controller automatically.</p> <p>0: 0 burst 1: 1 burst ... N: N bursts</p>
--	--	--	---

7.2.6.11. SPI Master Burst Control Counter Register(Default Value: 0x00000000)

Offset: 0x38			Register Name: SPI_BCC
Bit	R/W	Default/Hex	Description
31:29	R	0x0	Reserved
28	R/W	0x0	<p>DRM</p> <p>Master Dual Mode RX Enable</p> <p>0: RX use single-bit mode 1: RX use dual mode</p> <p>Note: Can't be written when XCH=1.</p>
27:24	R/W	0x0	<p>DBC</p> <p>Master Dummy Burst Counter</p> <p>In master mode, this field specifies the burst number that should be sent before receive in dual SPI mode. The data is don't care by the device.</p> <p>0: 0 burst 1: 1 burst ... N: N bursts</p> <p>Note: Can't be written when XCH=1.</p>
23:0	R/W	0x0	<p>STC</p> <p>Master Single Mode Transmit Counter</p> <p>In master mode, this field specifies the burst number that should be sent in single mode before automatically sending dummy burst. This is the first transmit counter in all bursts.</p> <p>0: 0 burst 1: 1 burst ... N: N bursts</p> <p>Note: Can't be written when XCH=1.</p>

7.2.6.12. SPI Normal DMA Mode Control Register(Default Value: 0x000000A5)

Offset: 0x88			Register Name: SPI_NDMA_MODE_CTL
Bit	R/W	Default/Hex	Description
7:0	R/W	0xA5	NDMA_MODE_CTL 0xEA:NDMA handshake mode Note:NDMA wait mode don't care this value.0xA5 can be used in handshake mode, but 0xEA is better.

7.2.6.13. SPI TX Data Register(Default Value: 0x00000000)

Offset: 0x200			Register Name: SPI_TXD
Bit	R/W	Default/Hex	Description
31:0	W/R	0x0	TDATA Transmit Data This register can be accessed in byte, half-word or word unit by AHB. In byte accessing method, if there are rooms in RXFIFO, one burst data is written to RXFIFO and the depth is increased by 1. In half-word accessing method, two SPI burst data are written and the TXFIFO depth is increase by 2. In word accessing method, four SPI burst data are written and the TXFIFO depth is increased by 4. Note: This address is writing-only if TF_TEST is '0', and if TF_TEST is set to '1', this address is readable and writable to test the TX FIFO through the AHB bus.

7.2.6.14. SPI RX Data Register(Default Value: 0x00000000)

Offset: 0x300			Register Name: SPI_RXD
Bit	R/W	Default/Hex	Description
31:0	R	0	RDATA Receive Data This register can be accessed in byte, half-word or word unit by AHB. In byte accessing method, if there are data in RXFIFO, the top word is returned and the RXFIFO depth is decreased by 1. In half-word accessing method, two SPI bursts are returned and the RXFIFO depth is decrease by 2. In word accessing method, the four SPI bursts are returned and the RXFIFO depth is decreased by 4. Note: This address is read-only if RF_TEST is '0', and if RF_TEST is set to '1', this address is readable and writable to test the RX FIFO through the AHB bus.

7.3. UART

7.3.1. Overview

The UART is used for serial communication with a peripheral, modem (data carrier equipment, DCE) or data set. Data is written from a master (CPU) over the APB bus to the UART and it is converted to serial form and transmitted to the destination device. Serial data is also received by the UART and stored for the master (CPU) to read back.

The UART contains registers to control the character length, baud rate, parity generation/checking, and interrupt generation. Although there is only one interrupt output signal from the UART, there are several prioritized interrupt types that can be responsible for its assertion. Each of the interrupt types can be separately enabled/disabled with the control registers.

The UART has 16450 and 16550 modes of operation, which are compatible with a range of standard software drivers. In 16550 mode, transmit and receive operations are both buffered by FIFOs. In 16450 mode, these FIFOs are disabled.

The UART supports data lengths from five to eight bits, an optional parity bit and 1, 1 ½ or 2 stop bits, and is fully programmable by an AMBA APB CPU interface. A 16-bit programmable baud rate generator and an 8-bit scratch register are included, together with separate transmit and receive FIFOs. Eight modem control lines and a diagnostic loop-back mode are provided.

Interrupts can be generated for a range of TX Buffer/FIFO, RX Buffer/FIFO, Modem Status and Line Status conditions.

For integration in system where Infrared SIR serial data format is required, the UART can be configured to have a software-programmable IrDA SIR Mode. If this mode is not selected, only the UART (RS232 standard) serial data format is available.

The UART includes the following features:

- Compatible with industry-standard 16550 UARTs
- 64-Bytes Transmit and receive data FIFOs
- DMA controller interface
- Software/ Hardware Flow Control
- Programmable Transmit Holding Register Empty interrupt
- Interrupt support for FIFOs, Status Change
- Support IrDA 1.0 SIR

7.3.2. UART Timing Diagram

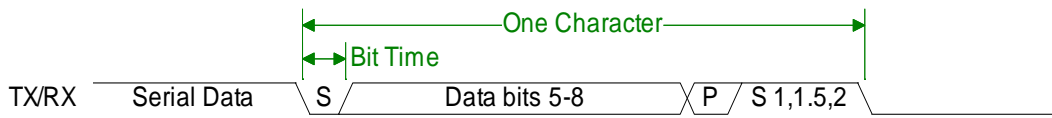

Figure 7-5. UART Serial Data Format

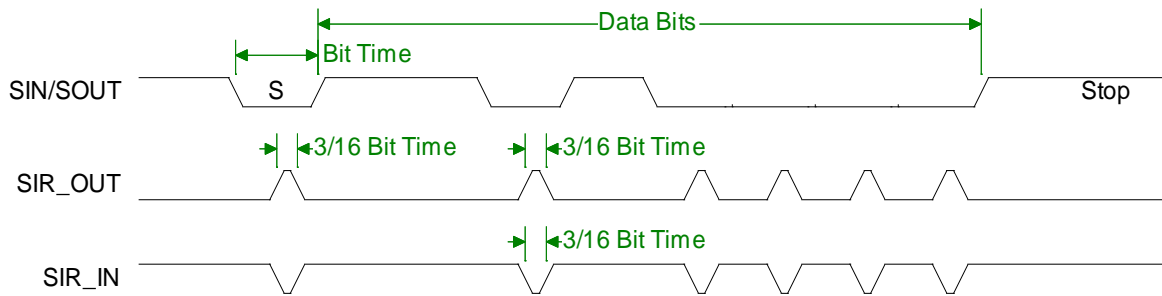

Figure 7-6. Serial IrDA Data Format

7.3.3. UART Pin List

Port Name	Width	Direction	Description
UART0_TX	1	OUT	UART Serial Bit output
UART0_RX	1	IN	UART Serial Bit input
UART1_TX	1	OUT	UART Serial Bit output
UART1_RX	1	IN	UART Serial Bit input
UART1_RTS	1	OUT	UART Request To Send This active low output signal informs Modem that the UART is ready to send data
UART1_CTS	1	IN	UART Clear To End This active low signal is an input showing when Modem is ready to accept data
UART2_TX	1	OUT	UART Serial Bit output
UART2_RX	1	IN	UART Serial Bit input
UART2_RTS	1	OUT	UART Request To Send This active low output signal informs Modem that the UART is ready to send data
UART2_CTS	1	IN	UART Clear To End This active low signal is an input showing when Modem is ready to accept data
UART3_TX	1	OUT	UART Serial Bit output

UART3_RX	1	IN	UART Serial Bit input
UART3_RTS	1	OUT	UART Request To Send This active low output signal informs Modem that the UART is ready to send data
UART3_CTS	1	IN	UART Clear To End This active low signal is an input showing when Modem is ready to accept data
UART4_TX	1	OUT	UART Serial Bit output
UART4_RX	1	IN	UART Serial Bit input
UART4_RTS	1	OUT	UART Request To Send This active low output signal informs Modem that the UART is ready to send data
UART4_CTS	1	IN	UART Clear To End This active low signal is an input showing when Modem is ready to accept data
S_UART_TX	1	OUT	UART Serial Bit output
S_UART_RX	1	IN	UART Serial Bit input

7.3.4. UART Controller Register List

There are 6 UART controllers. All UART controllers can be configured as Serial IrDA.

Module Name	Base Address
UART0	0x01C28000
UART1	0x01C28400
UART2	0x01C28800
UART3	0x01C28C00
UART4	0x01C29000
R-UART	0x01F02800

Register Name	Offset	Description
UART_RBR	0x00	UART Receive Buffer Register
UART_THR	0x00	UART Transmit Holding Register
UART_DLL	0x00	UART Divisor Latch Low Register
UART_DLH	0x04	UART Divisor Latch High Register
UART_IER	0x04	UART Interrupt Enable Register
UART_IIR	0x08	UART Interrupt Identity Register
UART_FCR	0x08	UART FIFO Control Register
UART_LCR	0x0C	UART Line Control Register
UART_MCR	0x10	UART Modem Control Register
UART_LSR	0x14	UART Line Status Register
UART_MSR	0x18	UART Modem Status Register

UART_SCH	0x1C	UART Scratch Register
UART_USR	0x7C	UART Status Register
UART_TFL	0x80	UART Transmit FIFO Level
UART_RFL	0x84	UART_RFL
UART_HALT	0xA4	UART Halt TX Register

7.3.5. UART Register Description

7.3.5.1. UART Receiver Buffer Register(Default Value: 0x00000000)

Offset: 0x0000			Register Name: UART_RBR
Bit	R/W	Default/Hex	Description
31:8	/	/	/
			<p>RBR Receiver Buffer Register Data byte received on the serial input port . The data in this register is valid only if the Data Ready (DR) bit in the UART Line Status Register (UART_LCR) is set.</p> <p>If in FIFO mode and FIFOs are enabled (UART_FCR[0] set to one), this register accesses the head of the receive FIFO. If the receive FIFO is full and this register is not read before the next data character arrives, then the data already in the FIFO is preserved, but any incoming data are lost and an overrun error occurs.</p>
7:0	R	0	

7.3.5.2. UART Transmit Holding Register(Default Value: 0x00000000)

Offset: 0x0000			Register Name: UART_THR
Bit	R/W	Default/Hex	Description
31:8	/	/	/
			<p>THR Transmit Holding Register Data to be transmitted on the serial output port . Data should only be written to the THR when the THR Empty (THRE) bit (UART_LSR[5]) is set. If in FIFO mode and FIFOs are enabled (UART_FCR[0] = 1) and THRE is set, 16 number of characters of data may be written to the THR before the FIFO is full. Any attempt to write data when the FIFO is full results in the write data being lost.</p>
7:0	W	0	

7.3.5.3. UART Divisor Latch Low Register(Default Value: 0x00000000)

Offset: 0x0000			Register Name: UART_DLL
Bit	R/W	Default/Hex	Description
31:8	/	/	/
7:0	R/W	0	<p>DLL Divisor Latch Low</p> <p>Lower 8 bits of a 16-bit, read/write, Divisor Latch register that contains the baud rate divisor for the UART. This register may only be accessed when the DLAB bit (UART_LCR[7]) is set and the UART is not busy (UART_USR[0] is zero).</p> <p>The output baud rate is equal to the serial clock (sclk) frequency divided by sixteen times the value of the baud rate divisor, as follows: baud rate = (serial clock freq) / (16 * divisor).</p> <p>Note that with the Divisor Latch Registers (DLL and DLH) set to zero, the baud clock is disabled and no serial communications occur. Also, once the DLL is set, at least 8 clock cycles of the slowest UART clock should be allowed to pass before transmitting or receiving data.</p>

7.3.5.4. UART Divisor Latch High Register(Default Value: 0x00000000)

Offset: 0x0004			Register Name: UART_DLH
Bit	R/W	Default/Hex	Description
31:8	/	/	/
7:0	R/W	0	<p>DLH Divisor Latch High</p> <p>Upper 8 bits of a 16-bit, read/write, Divisor Latch register that contains the baud rate divisor for the UART. This register may only be accessed when the DLAB bit (UART_LCR[7]) is set and the UART is not busy (UART_USR [0] is zero).</p> <p>The output baud rate is equal to the serial clock (sclk) frequency divided by sixteen times the value of the baud rate divisor, as follows: baud rate = (serial clock freq) / (16 * divisor).</p> <p>Note that with the Divisor Latch Registers (DLL and DLH) set to zero, the baud clock is disabled and no serial communications occur. Also, once the DLH is set, at least 8 clock cycles of the slowest UART clock should be allowed to pass before transmitting or receiving data.</p>

7.3.5.5. UART Interrupt Enable Register(Default Value: 0x00000000)

Offset: 0x0004			Register Name: UART_IER
Bit	R/W	Default/Hex	Description
31:8	/	/	/
7	R/W		PTIME Programmable THRE Interrupt Mode Enable This is used to enable/disable the generation of THRE Interrupt. 0: Disable 1: Enable
6:4	/	/	/
3	R/W	0	EDSSI Enable Modem Status Interrupt This is used to enable/disable the generation of Modem Status Interrupt. This is the fourth highest priority interrupt. 0: Disable 1: Enable
2	R/W	0	ELSI Enable Receiver Line Status Interrupt This is used to enable/disable the generation of Receiver Line Status Interrupt. This is the highest priority interrupt. 0: Disable 1: Enable
1	R/W	0	ETBEI Enable Transmit Holding Register Empty Interrupt This is used to enable/disable the generation of Transmitter Holding Register Empty Interrupt. This is the third highest priority interrupt. 0: Disable 1: Enable
0	R/W	0	ERBFI Enable Received Data Available Interrupt This is used to enable/disable the generation of Received Data Available Interrupt and the Character Timeout Interrupt (if in FIFO mode and FIFOs enabled). These are the second highest priority interrupts. 0: Disable 1: Enable

7.3.5.6. UART Interrupt Identity Register(Default Value: 0x00000000)

Offset: 0x0008			Register Name: UART_IIR
Bit	R/W	Default/Hex	Description
31:8	/	/	/

7:6	R	0	FEFLAG FIFOs Enable Flag This is used to indicate whether the FIFOs are enabled or disabled. 00: Disable 11: Enable
5:4	/	/	/
3:0	R	0x1	IID Interrupt ID This indicates the highest priority pending interrupt which can be one of the following types: 0000: modem status 0001: no interrupt pending 0010: THR empty 0100: received data available 0110: receiver line status 0111: busy detect 1100: character timeout Bit 3 indicates an interrupt can only occur when the FIFOs are enabled and used to distinguish a Character Timeout condition interrupt.

Interrupt ID	Priority Level	Interrupt Type	Interrupt Source	Interrupt Reset
0001	-	None	None	-
0110	Highest	Receiver line status	Overrun/parity/framing errors or break interrupt	Reading UART Line Status Register
0100	Second	Received data available	Receiver data available (non-FIFO mode or FIFOs disabled) or RCVR FIFO trigger level reached (FIFO mode and FIFOs enabled)	Reading UART Receiver Buffer Register (non-FIFO mode or FIFOs disabled) or the FIFO drops below the trigger level (FIFO mode and FIFOs enabled)
1100	Second	Character timeout indication	No characters in or out of the RCVR FIFO during the last 4 character times and there is at least 1 character in it during This time	Reading UART Receiver Buffer Register
0010	Third	Transmit holding register empty	Transmitter holding register empty (Program THRE Mode disabled) or XMIT FIFO at or below threshold (Program THRE Mode enabled)	Reading UART Interrupt Identity Register (if source of interrupt); or, writing into THR (FIFOs or THRE Mode not selected or disabled) or XMIT FIFO above threshold (FIFOs and THRE Mode selected and enabled).
0000	Fourth	Modem status	Clear to send or data set	Reading the Modem status Register

			ready or ring indicator or data carrier detect. Note that if auto flow control mode is enabled, a change in CTS (that is, DCTS set) does not cause an interrupt.	
0111	Fifth	Busy detect indication	UART_16550_COMPATIBLE = NO and master has tried to write to the Line Control Register while the UART is busy (UART_USR[0] is set to one).	Reading the UART status register

7.3.5.7. UART FIFO Control Register(Default Value: 0x00000000)

Offset: 0x0008			Register Name: UART_FCR
Bit	R/W	Default/Hex	Description
31:8	/	/	/
7:6	W	0	<p>RT RCVR Trigger</p> <p>This is used to select the trigger level in the receiver FIFO at which the Received Data Available Interrupt is generated. In auto flow control mode it is used to determine when the rts_n signal is de-asserted. It also determines when the dma_rx_req_n signal is asserted in certain modes of operation.</p> <p>00: 1 character in the FIFO 01: FIFO ¼ full 10: FIFO ½ full 11: FIFO-2 less than full</p>
5:4	W	0	<p>TFT TX Empty Trigger</p> <p>Writes have no effect when THRE_MODE_USER = Disabled. This is used to select the empty threshold level at which the THRE Interrupts are generated when the mode is active. It also determines when the dma_tx_req_n signal is asserted when in certain modes of operation.</p> <p>00: FIFO empty 01: 2 characters in the FIFO 10: FIFO ¼ full 11: FIFO ½ full</p>
3	W	0	<p>DMAM DMA Mode</p> <p>0: Mode 0 1: Mode 1</p>

2	W	0	<p>XFIFOR XMIT FIFO Reset</p> <p>This resets the control portion of the transmit FIFO and treats the FIFO as empty. This also de-asserts the DMA TX request. It is 'self-clearing'. It is not necessary to clear this bit.</p>
1	W	0	<p>RFIFOR RCVR FIFO Reset</p> <p>This resets the control portion of the receive FIFO and treats the FIFO as empty. This also de-asserts the DMA RX request. It is 'self-clearing'. It is not necessary to clear this bit.</p>
0	W	0	<p>FIFOE Enable FIFOs</p> <p>This enables/disables the transmit (XMIT) and receive (RCVR) FIFOs. Whenever the value of this bit is changed both the XMIT and RCVR controller portion of FIFOs is reset.</p>

7.3.5.8. UART Line Control Register(Default Value: 0x0000000)

Offset: 0x000C			Register Name: UART_LCR
Bit	R/W	Default/Hex	Description
31:8	/	/	/
7	R/W	0	<p>DLAB Divisor Latch Access Bit</p> <p>It is writeable only when UART is not busy (UART_USR[0] is zero) and always readable. This bit is used to enable reading and writing of the Divisor Latch register (UART_DLL and UART_DLH) to set the baud rate of the UART. This bit must be cleared after initial baud rate setup in order to access other registers.</p> <p>0: Select UART Receiver Buffer Register(UART_RBR) / UART Transmit Holding Register (UART_THR) and UART Interrupt Enable Register(UART_IER)</p> <p>1: Select UART Divisor Latch Low Register(UART_DLL) and UART Divisor Latch High Register (UART_DLH)</p>
6	R/W	0	<p>BC Break Control Bit</p> <p>This is used to cause a break condition to be transmitted to the receiving device. If set to one the serial output is forced to the spacing (logic 0) state. When not in Loop Back Mode, as determined by UART_MCR[4], the sout line is forced low until the Break bit is cleared. If SIR_MODE = Enabled and active (UART_MCR[6] set to one) the sir_out_n line is continuously pulsed. When in Loop Back Mode, the break condition is internally looped back to the receiver and the sir_out_n line is forced low.</p>
5:4	R/W	0	EPS

			<p>Even Parity Select</p> <p>It is writeable only when UART is not busy (UART_USR[0] is zero) and always writable readable. This is used to select between even and odd parity, when parity is enabled (PEN set to one). Setting the UART_LCR[5] is to reverse the UART_LCR[4].</p> <p>00: Odd Parity 01: Even Parity 1X: Reverse LCR[4]</p>
3	R/W	0	<p>PEN</p> <p>Parity Enable</p> <p>It is writeable only when UART is not busy (UART_USR[0] is zero) and always readable. This bit is used to enable and disable parity generation and detection in transmitted and received serial character respectively.</p> <p>0: parity disabled 1: parity enabled</p>
2	R/W	0	<p>STOP</p> <p>Number of stop bits</p> <p>It is writeable only when UART is not busy (UART_USR[0] is zero) and always readable. This is used to select the number of stop bits per character that the peripheral transmits and receives. If set to zero, one stop bit is transmitted in the serial data. If set to one and the data bits are set to 5 (UART_LCR[1:0] set to zero) one and a half stop bits is transmitted. Otherwise, two stop bits are transmitted. Note that regardless of the number of stop bits selected, the receiver checks only the first stop bit.</p> <p>0: 1 stop bit 1: 1.5 stop bits when DLS (UART_LCR[1:0]) is zero, else 2 stop bit</p>
1:0	R/W	0	<p>DLS</p> <p>Data Length Select</p> <p>It is writeable only when UART is not busy (UART_USR[0] is zero) and always readable. This is used to select the number of data bits per character that the peripheral transmits and receives. The number of bit that may be selected areas follows:</p> <p>00: 5 bits 01: 6 bits 10: 7 bits 11: 8 bits</p>

7.3.5.9. UART Modem Control Register(Default Value: 0x00000000)

Offset: 0x0010			Register Name: UART_MCR
Bit	R/W	Default/Hex	Description
31:7	/	/	/

6	R/W	0	<p>SIRE</p> <p>SIR Mode Enable</p> <p>0:IrDA SIR Mode disable</p> <p>1:IrDA SIR Mode enable</p>
5	R/W	0	<p>AFCE</p> <p>Auto Flow Control Enable</p> <p>When FIFOs are enabled and the Auto Flow Control Enable (AFCE) bit is set, Auto Flow Control features are enabled.</p> <p>0: Auto Flow Control Mode disabled</p> <p>1: Auto Flow Control Mode enabled</p>
4	R/W	0	<p>LOOP</p> <p>Loop Back Mode</p> <p>0: Normal Mode</p> <p>1: Loop Back Mode</p> <p>This is used to put the UART into a diagnostic mode for test purposes. If operating in UART mode (SIR_MODE != Enabled or not active, UART_MCR[6] set to zero), data on the sout line is held high, while serial data output is looped back to the sin line, internally. In this mode all the interrupts are fully functional. Also, in Loop Back Mode, the modem control inputs (dsr_n, cts_n, ri_n, dcd_n) are disconnected and the modem control outputs (dtr_n, rts_n, out1_n, out2_n) are looped back to the inputs, internally. If operating in infrared mode (SIR_MODE == Enabled AND active, UART_MCR[6] set to one), data on the sir_out_n line is held low, while serial data output is inverted and looped back to the sir_in line.</p>
3:2	/	/	/
1	R/W	0	<p>RTS</p> <p>Request to Send</p> <p>This is used to directly control the Request to Send (rts_n) output. The Request To Send (rts_n) output is used to inform the modem or data set that the UART is ready to exchange data. When Auto RTS Flow Control is not enabled (UART_MCR[5] set to zero), the rts_n signal is set low by programming UART_MCR[1] (RTS) to a high. In Auto Flow Control, AFCE_MODE == Enabled and active (UART_MCR[5] set to one) and FIFOs enable (FCR[0] set to one), the rts_n output is controlled in the same way, but is also gated with the receiver FIFO threshold trigger (rts_n is inactive high when above the threshold). The rts_n signal is de-asserted when UART_MCR[1] is set low.</p> <p>0: rts_n de-asserted (logic 1)</p> <p>1: rts_n asserted (logic 0)</p> <p>Note that in Loop Back Mode (UART_MCR[4] set to one), the rts_n output is held inactive high while the value of this location is internally looped back to an input.</p>
0	R/W	0	DTR

			<p>Data Terminal Ready</p> <p>This is used to directly control the Data Terminal Ready (dtr_n) output. The value written to this location is inverted and driven out on dtr_n.</p> <p>0: dtr_n de-asserted (logic 1) 1: dtr_n asserted (logic 0)</p> <p>The Data Terminal Ready output is used to inform the modem or data set that the UART is ready to establish communications.</p> <p>Note that in Loop Back Mode(UART_MCR[4] set to one), the dtr_n output is held inactive high while the value of this location is internally looped back to an input.</p>
--	--	--	---

7.3.5.10. UART Line Status Register(Default Value: 0x00000060)

Offset: 0x0014			Register Name: UART_LSR
Bit	R/W	Default/Hex	Description
31:8	/	/	/
7	R	0	<p>FIFOERR RX Data Error in FIFO</p> <p>When FIFOs are disabled, this bit is always 0. When FIFOs are enabled, this bit is set to 1 when there is at least one PE, FE, or BI in the RX FIFO. It is cleared by a read from the LSR register provided there are no subsequent errors in the FIFO.</p>
6	R	1	<p>TEMT Transmitter Empty</p> <p>If the FIFOs are disabled, this bit is set to "1" whenever the TX Holding Register and the TX Shift Register are empty. If the FIFOs are enabled, this bit is set whenever the TX FIFO and the TX Shift Register are empty. In both cases, this bit is cleared when a byte is written to the TX data channel.</p>
5	R	1	<p>THRE TX Holding Register Empty</p> <p>If the FIFOs are disabled, this bit is set to "1" whenever the TX Holding Register is empty and ready to accept new data and it is cleared when the CPU writes to the TX Holding Register.</p> <p>If the FIFOs are enabled, this bit is set to "1" whenever the TX FIFO is empty and it is cleared when at least one byte is written to the TX FIFO.</p>
4	R	0	<p>BI Break Interrupt</p> <p>This is used to indicate the detection of a break sequence on the serial input data.</p> <p>If in UART mode(SIR_MODE=Disable),it is set whenever the serial input,</p>

			<p>sin, is held in a logic '0' state for longer than the sum of <i>start time + data bits + parity + stop</i> bits.</p> <p>If in infrared mode(SIR_MODE=Enable),it is set whenever the serial input, sir_in,is continuously pulsed to logic '0' for longer than the sum of <i>start time + data bits + parity + stop</i> bits.Abreak condition on serial input causes one and only one character,consisting of all zeros,to be received by the UART.</p> <p>In the FIFO mode, the character associated with the break condition is carried through the FIFO and is revealed when the character is at the top of the FIFO. Reading the LSR clears the BI bit. In the non-FIFO mode, the BI indication occurs immediately and persists until the LSR is read.</p>
3	R	0	<p>FE Framing Error</p> <p>This is used to indicate the occurrence of a framing error in the receiver. A framing error occurs when the receiver does not detect a valid STOP bit in the received data.</p> <p>In the FIFO mode, since the framing error is associated with a character received, it is revealed when the character with the framing error is at the top of the FIFO. When a framing error occurs, the UART tries to resynchronize. It does this by assuming that the error was due to the start bit of the next character and then continues receiving the other bit i.e. data, and/or parity and stop. It should be noted that the Framing Error (FE) bit (UART_LSR[3]) is set if a break interrupt has occurred, as indicated by Break Interrupt (BI) bit (UART_LSR[4]).</p> <p>0: no framing error 1:framing error</p> <p>Reading the LSR clears the FE bit.</p>
2	R	0	<p>PE Parity Error</p> <p>This is used to indicate the occurrence of a parity error in the receiver if the Parity Enable (PEN) bit (UART_LCR[3]) is set. In the FIFO mode, since the parity error is associated with a character received, it is revealed when the character with the parity error arrives at the top of the FIFO. It should be noted that the Parity Error (PE) bit (UART_LSR[2]) is set if a break interrupt has occurred, as indicated by Break Interrupt(BI) bit (UART_LSR[4]).</p> <p>0: no parity error 1: parity error</p> <p>Reading the LSR clears the PE bit.</p>
1	R	0	<p>OE Overrun Error</p>

			<p>This occurs if a new data character was received before the previous data was read. In the non-FIFO mode, the OE bit is set when a new character arrives in the receiver before the previous character was read from the RBR. When this happens, the data in the RBR is overwritten. In the FIFO mode, an overrun error occurs when the FIFO is full and a new character arrives at the receiver. The data in the FIFO is retained and the data in the receive shift register is lost.</p> <p>0: no overrun error 1: overrun error Reading the LSR clears the OE bit.</p>
0	R	0	<p>DR Data Ready This is used to indicate that the receiver contains at least one character in the RBR or the receiver FIFO.</p> <p>0: no data ready 1: data ready This bit is cleared when the RBR is read in non-FIFO mode, or when the receiver FIFO is empty, in FIFO mode.</p>

7.3.5.11. UART Modem Status Register(Default Value: 0x00000000)

Offset: 0x0018			Register Name: UART_MSR
Bit	R/W	Default/Hex	Description
31:8	/	/	/
7	R	0	<p>DCD Line State of Data Carrier Detect This is used to indicate the current state of the modem control line dcd_n. This bit is the complement of dcd_n. When the Data Carrier Detect input (dcd_n) is asserted it is an indication that the carrier has been detected by the modem or data set.</p> <p>0: dcd_n input is de-asserted (logic 1) 1: dcd_n input is asserted (logic 0)</p>
6	R	0	<p>RI Line State of Ring Indicator This is used to indicate the current state of the modem control line ri_n. This bit is the complement of ri_n. When the Ring Indicator input (ri_n) is asserted it is an indication that a telephone ringing signal has been received by the modem or data set.</p> <p>0: ri_n input is de-asserted (logic 1) 1: ri_n input is asserted (logic 0)</p>
5	R	0	<p>DSR Line State of Data Set Ready This is used to indicate the current state of the modem control line dsr_n.</p>

			<p>This bit is the complement of dsr_n. When the Data Set Ready input (dsr_n) is asserted it is an indication that the modem or data set is ready to establish communications with UART.</p> <p>0: dsr_n input is de-asserted (logic 1) 1: dsr_n input is asserted (logic 0)</p> <p>In Loop Back Mode (UART_MCR[4] set to one), DSR is the same as UART_MCR[0] (DTR).</p>
4	R	0	<p>CTS Line State of Clear To Send</p> <p>This is used to indicate the current state of the modem control line cts_n. This bit is the complement of cts_n. When the Clear to Send input (cts_n) is asserted it is an indication that the modem or data set is ready to exchange data with UART.</p> <p>0: cts_n input is de-asserted (logic 1) 1: cts_n input is asserted (logic 0)</p> <p>In Loop Back Mode (UART_MCR[4] = 1), CTS is the same as UART_MCR[1] (RTS).</p>
3	R	0	<p>DDCD Delta Data Carrier Detect</p> <p>This is used to indicate that the modem control line dcd_n has changed since the last time the MSR was read.</p> <p>0: no change on dcd_n since last read of MSR 1: change on dcd_n since last read of MSR</p> <p>Reading the MSR clears the DDCD bit.</p> <p>Note: If the DDCD bit is not set and the dcd_n signal is asserted (low) and a reset occurs (software or otherwise), then the DDCD bit is set when the reset is removed if the dcd_n signal remains asserted.</p>
2	R	0	<p>TERI Trailing Edge Ring Indicator</p> <p>This is used to indicate that a change on the input ri_n (from an active-low to an inactive-high state) has occurred since the last time the MSR was read.</p> <p>0: no change on ri_n since last read of MSR 1: change on ri_n since last read of MSR</p> <p>Reading the MSR clears the TERI bit.</p>
1	R	0	<p>DDSR Delta Data Set Ready</p> <p>This is used to indicate that the modem control line dsr_n has changed since the last time the MSR was read.</p> <p>0: no change on dsr_n since last read of MSR 1: change on dsr_n since last read of MSR</p> <p>Reading the MSR clears the DDSR bit. In Loop Back Mode (UART_MCR[4] = 1), DDSR reflects changes on UART_MCR[0] (DTR).</p> <p>Note: If the DDSR bit is not set and the dsr_n signal is asserted (low) and</p>

			a reset occurs (software or otherwise), then the DDSR bit is set when the reset is removed if the dsr_n signal remains asserted.
0	R	0	<p>DCTS Delta Clear to Send</p> <p>This is used to indicate that the modem control line cts_n has changed since the last time the MSR was read.</p> <p>0: no change on ctsdsr_n since last read of MSR 1: change on ctsdsr_n since last read of MSR</p> <p>Reading the MSR clears the DCTS bit. In Loop Back Mode (UART_MCR[4] = 1), DCTS reflects changes on UART_MCR[1] (RTS).</p> <p>Note: If the DCTS bit is not set and the cts_n signal is asserted (low) and a reset occurs (software or otherwise), then the DCTS bit is set when the reset is removed if the cts_n signal remains asserted.</p>

7.3.5.12. UART Scratch Register(Default Value: 0x00000000)

Offset: 0x001C			Register Name: UART_SCH
Bit	R/W	Default/Hex	Description
31:8	/	/	/
7:0	R/W	0	<p>SCRATCH_REG Scratch Register</p> <p>This register is for programmers to use as a temporary storage space. It has no defined purpose in the UART.</p>

7.3.5.13. UART Status Register(Default Value: 0x00000006)

Offset: 0x007C			Register Name: UART_USR
Bit	R/W	Default/Hex	Description
31:5	/	/	/
4	R	0	<p>RFF Receive FIFO Full</p> <p>This is used to indicate that the receive FIFO is completely full.</p> <p>0: Receive FIFO not full 1: Receive FIFO Full</p> <p>This bit is cleared when the RX FIFO is no longer full.</p>
3	R	0	<p>RFNE Receive FIFO Not Empty</p> <p>This is used to indicate that the receive FIFO contains one or more entries.</p> <p>0: Receive FIFO is empty 1: Receive FIFO is not empty</p>

			This bit is cleared when the RX FIFO is empty.
2	R	1	TFE Transmit FIFO Empty This is used to indicate that the transmit FIFO is completely empty. 0: Transmit FIFO is not empty 1: Transmit FIFO is empty This bit is cleared when the TX FIFO is no longer empty.
1	R	1	TFNF Transmit FIFO Not Full This is used to indicate that the transmit FIFO is not full. 0: Transmit FIFO is full 1: Transmit FIFO is not full This bit is cleared when the TX FIFO is full.
0	R	0	BUSY UART Busy Bit 0: Idle or inactive 1: Busy

7.3.5.14. UART Transmit FIFO Level Register(Default Value: 0x00000000)

Offset: 0x0080			Register Name: UART_TFL
Bit	R/W	Default/Hex	Description
31:7	/	/	/
6:0	R	0	TFL Transmit FIFO Level This indicates the number of data entries in the transmit FIFO.

7.3.5.15. UART Receive FIFO Level Register(Default Value: 0x00000000)

Offset: 0x0084			Register Name: UART_RFL
Bit	R/W	Default/Hex	Description
31:7	/	/	/
6:0	R	0	RFL Receive FIFO Level This indicates the number of data entries in the receive FIFO.

7.3.5.16. UART Halt TX Register(Default Value: 0x00000000)

Offset: 0x00A4			Register Name: UART_HALT
Bit	R/W	Default/Hex	Description

31:4	/	/	/
5	R/W	0	<p>SIR_RX_INVERT SIR Receiver Pulse Polarity Invert 0: Not invert receiver signal 1: Invert receiver signal</p>
4	R/W	0	<p>SIR_TX_INVERT SIR Transmit Pulse Polarity Invert 0: Not invert transmit pulse 1: Invert transmit pulse</p>
3	/	/	/
2	R/W	0	<p>CHANGE_UPDATE After the user using HALT[1] to change the baudrate or LCR configuration, write 1 to update the configuration and waiting this bit self clear to 0 to finish update process. Write 0 to this bit has no effect. 1: Update trigger, Self clear to 0 when finish update.</p>
1	R/W	0	<p>CHCFG_AT_BUSY This is an enable bit for the user to change LCR register configuration (except for the DLAB bit) and baudrate register (DLH and DLL) when the UART is busy (UART_USR[0] is 1). 1: Enable change when busy</p>
0	R/W	0	<p>HALT_TX Halt TX This register is use to halt transmissions for testing, so that the transmit FIFO can be filled by the master when FIFOs are implemented and enabled. 0 : Halt TX disabled 1 : Halt TX enabled Note: If FIFOs are not enabled, the setting of the halt TX register has no effect on operation.</p>

7.4. CIR Receiver

7.4.1. Overview

The CIR includes the following features:

- Full physical layer implementation
- Support CIR for remote control
- 64x8 bits FIFO for data buffer
- Programmable FIFO thresholds

For saving CPU resource, CIR receiver is implemented in hardware. The CIR receiver samples the input signal on the programmable frequency and records these samples into RX FIFO when one CIR signal is found on the air. The CIR receiver uses Run-Length Code (RLC) to encode pulse width. The encoded data is buffered in a 64 levels and 8-bit width RX FIFO; the MSB bit is used to record the polarity of the receiving CIR signal. The high level is represented as '1' and the low level is represented as '0'. The rest 7 bits are used for the length of RLC. The maximum length is 128. If the duration of one level (high or low level) is more than 128, another byte is used.

In the air, there is always some noise. One threshold can be set to filter the noise to reduce system loading and improve the system stability.

7.4.2. CIR Receiver Register List

Module Name	Base Address
CIR	0x01F02000

Register Name	Offset	Description
CIR_CTL	0x00	CIR Control Register
CIR_RXCTL	0x10	CIR Receiver Configure Register
CIR_RXFIFO	0x20	CIR Receiver FIFO Register
CIR_RXINT	0x2C	CIR Receiver Interrupt Control Register
CIR_RXSTA	0x30	CIR Receiver Status Register
CIR_CONFIG	0x34	CIR Configure Register

7.4.3. CIR Receiver Register Description

7.4.3.1. CIR Receiver Control Register(Default Value: 0x00000000)

Offset: 0x0000			Register Name: CIR_CTL
Bit	R/W	Default/Hex	Description
31:9	/	/	/
8	R/W	0	CGPO General Program Output (GPO) Control in CIR mode for TX Pin 0: Low level 1: High level
7:6	/	/	/
5:4	R/W	0	CIR ENABLE 00~10: Reserved 11: CIR mode enable
3:2	/	/	/
1	R/W	0	RXEN Receiver Block Enable 0: Disable 1: Enable
0	R/W	0	GEN Global Enable A disable on this bit overrides any other block or channel enables and flushes all FIFOs. 0: Disable 1: Enable

7.4.3.2. CIR Receiver Configure Register(Default Value: 0x00000004)

Offset: 0x0010			Register Name: CIR_RXCTL
Bit	R/W	Default/Hex	Description
31:3	/	/	/
2	R/W	1	RPPI Receiver Pulse Polarity Invert 0: Not invert receiver signal 1: Invert receiver signal
1:0	/	/	/

7.4.3.3. CIR Receiver FIFO Register(Default Value: 0x00000000)

Offset: 0x0020			Register Name: CIR_RXFIFO
Bit	R/W	Default/Hex	Description
31:8	/	/	/
7:0	R	0	Receiver Byte FIFO

7.4.3.4. CIR Receiver Interrupt Control Register(Default Value: 0x00000000)

Offset: 0x002C			Register Name: CIR_RXINT
Bit	R/W	Default/Hex	Description
31:14	/	/	/
13:8	R/W	0	RAL RX FIFO Available Received Byte Level for interrupt and DMA request TRIGGER_LEVEL = RAL + 1
5	R/W	0	DRQ_EN RX FIFO DMA Enable 0: Disable 1: Enable When set to '1', the Receiver FIFO DRQ is asserted if reaching RAL. The DRQ is de-asserted when condition fails.
4	R/W	0	RAI_EN RX FIFO Available Interrupt Enable 0: Disable 1: Enable When set to '1', the Receiver FIFO IRQ is asserted if reaching RAL. The IRQ is de-asserted when condition fails.
3:2	/	/	/
1	R/W	0	RPEI_EN Receiver Packet End Interrupt Enable 0: Disable 1: Enable
0	R/W	0	ROI_EN Receiver FIFO Overrun Interrupt Enable 0: Disable 1: Enable

7.4.3.5. CIR Receiver Status Register(Default Value: 0x00000000)

Offset: 0x0030			Register Name: CIR_RXSTA
Bit	R/W	Default/Hex	Description

31:15	/	/	/
			RAC RX FIFO Available Counter 0: No available data in RX FIFO 1: 1 byte available data in RX FIFO 2: 2 byte available data in RX FIFO ... 64: 64 byte available data in RX FIFO
14:8	R	0	
			STAT Status of CIR 0x0 – Idle 0x1 – busy
7	R	0x0	
6:5	/	/	/
			RA RX FIFO Available 0: RX FIFO not available according its level 1: RX FIFO available according its level This bit is cleared by writing a ‘1’.
4	R/W	0	
3:2	/	/	/
			RPE Receiver Packet End Flag 0: STO was not detected. In CIR mode, one CIR symbol is receiving or not detected. 1: STO field or packet abort symbol (7'b0000,000 and 8'b0000,0000 for MIR and FIR) is detected. In CIR mode, one CIR symbol is received. This bit is cleared by writing a ‘1’.
1	R/W	0	
			ROI Receiver FIFO Overrun 0: Receiver FIFO not overrun 1: Receiver FIFO overrun This bit is cleared by writing a ‘1’.
0	R/W	0	

7.4.3.6. CIR Receiver Configure Register(Default Value: 0x00000000)

Offset: 0x0034			Register Name: CIR_RCR
Bit	R/W	Default/Hex	Description
31	/	/	/
30:25	/	/	/
			SCS2 Bit2 of Sample Clock Select for CIR This bit is defined by SCS bits below.
24	R/W	0x0	
			ATHC Active Threshold Control for CIR
23	R/W	0x0	

			<p>0x0 –ATHR in Unit of (Sample Clock) 0x1 –ATHR in Unit of (128*Sample Clocks)</p>																																				
22:16	R/W	0x0	<p>ATHR Active Threshold for CIR These bits control the duration of CIR from Idle to Active State. The duration can be calculated by ((ATHR + 1)*(ATHC? Sample Clock: 128*Sample Clock)).</p>																																				
15:8	R/W	0x18	<p>ITHR Idle Threshold for CIR The Receiver uses it to decide whether the CIR command has been received. If there is no CIR signal on the air, the receiver is staying in IDLE status. One active pulse will bring the receiver from IDLE status to Receiving status. After the CIR is end, the inputting signal will keep the specified level (high or low level) for a long time. The receiver can use this idle signal duration to decide that it has received the CIR command. The corresponding flag is asserted. If the corresponding interrupt is enable, the interrupt line is asserted to CPU. When the duration of signal keeps one status (high or low level) for the specified duration ((ITHR + 1)*128 sample_clk), this means that the previous CIR command has been finished.</p>																																				
7:2	R/W	0xa	<p>NTHR Noise Threshold for CIR When the duration of signal pulse (high or low level) is less than NTHR, the pulse is taken as noise and should be discarded by hardware. 0: all samples are recorded into RX FIFO 1: If the signal is only one sample duration, it is taken as noise and discarded. 2: If the signal is less than (<=) two sample duration, it is taken as noise and discarded. ... 61: if the signal is less than (<=) sixty-one sample duration, it is taken as noise and discarded.</p>																																				
1:0	R/W	0	<p>SCS Sample Clock Select for CIR</p> <table border="1"> <thead> <tr> <th>SCS2</th> <th>SCS[1]</th> <th>SCS[0]</th> <th>Sample Clock</th> </tr> </thead> <tbody> <tr> <td>0</td> <td>0</td> <td>0</td> <td>ir_clk/64</td> </tr> <tr> <td>0</td> <td>0</td> <td>1</td> <td>ir_clk/128</td> </tr> <tr> <td>0</td> <td>1</td> <td>0</td> <td>ir_clk/256</td> </tr> <tr> <td>0</td> <td>1</td> <td>1</td> <td>ir_clk/512</td> </tr> <tr> <td>1</td> <td>0</td> <td>0</td> <td>ir_clk</td> </tr> <tr> <td>1</td> <td>0</td> <td>1</td> <td>Reserved</td> </tr> <tr> <td>1</td> <td>1</td> <td>0</td> <td>Reserved</td> </tr> <tr> <td>1</td> <td>1</td> <td>1</td> <td>Reserved</td> </tr> </tbody> </table>	SCS2	SCS[1]	SCS[0]	Sample Clock	0	0	0	ir_clk/64	0	0	1	ir_clk/128	0	1	0	ir_clk/256	0	1	1	ir_clk/512	1	0	0	ir_clk	1	0	1	Reserved	1	1	0	Reserved	1	1	1	Reserved
SCS2	SCS[1]	SCS[0]	Sample Clock																																				
0	0	0	ir_clk/64																																				
0	0	1	ir_clk/128																																				
0	1	0	ir_clk/256																																				
0	1	1	ir_clk/512																																				
1	0	0	ir_clk																																				
1	0	1	Reserved																																				
1	1	0	Reserved																																				
1	1	1	Reserved																																				

7.5. USB

7.5.1. USB Controller Block Diagram

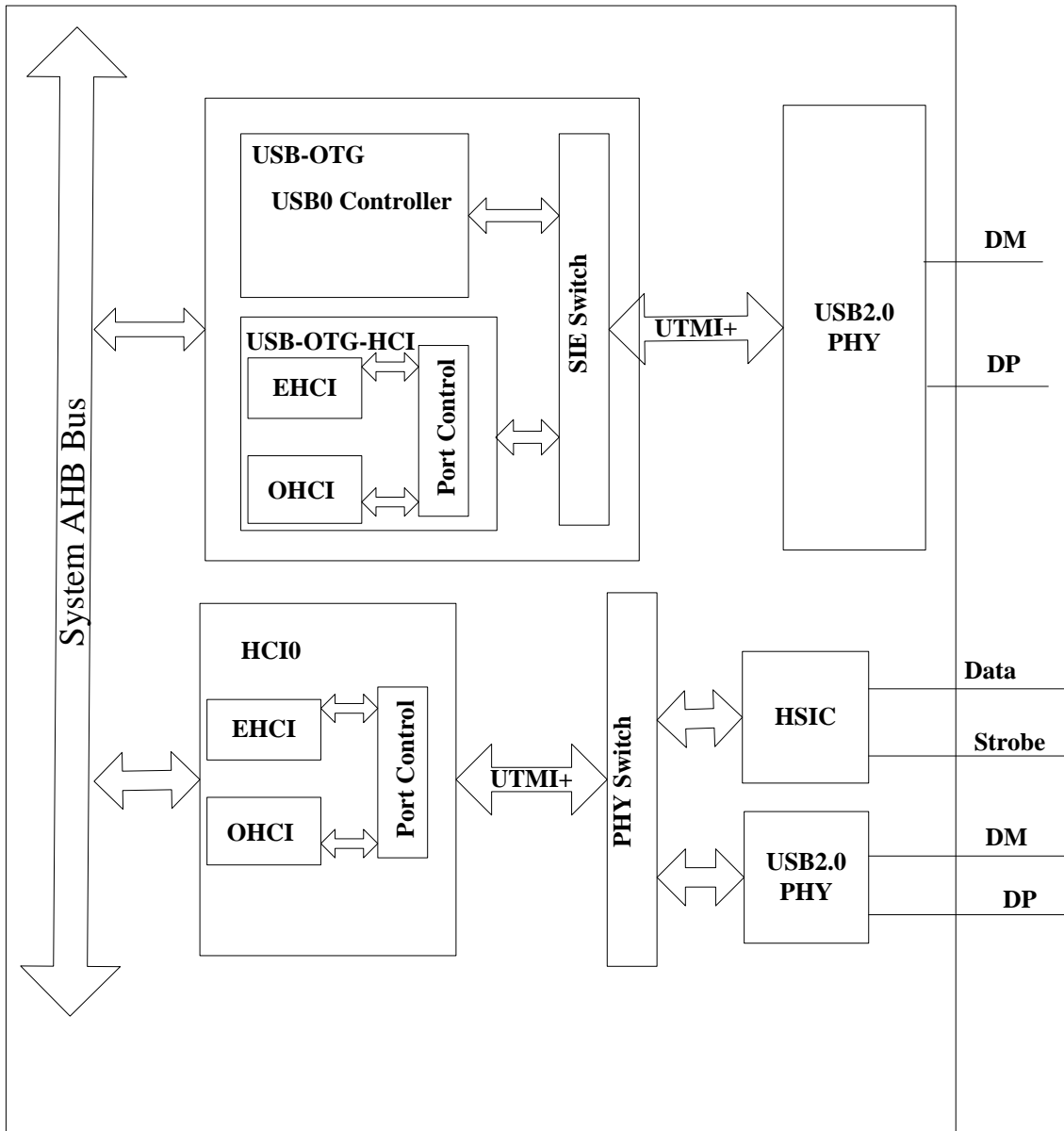

Figure 7-7. USB Controller Block Diagram

7.5.2. USB OTG

7.5.2.1. Overview

The USB OTG is a Dual-Role Device controller, which supports both device and host functions which can also be configured as a Host-only or Device-only controller, fully compliant with the USB 2.0 Specification. It can support high-speed (HS, 480-Mbps), full-speed (FS, 12-Mbps), and low-speed (LS, 1.5-Mbps) transfers in Host mode. It can support high-speed (HS, 480-Mbps), and full-speed (FS, 12-Mbps) in Device mode. Standard USB transceiver can be used through its UTMI+PHY Level3 interface. The UTMI+PHY interface is bidirectional with 8-bit data bus. For saving CPU bandwidth, USB-OTG DMA interface can support external DMA controller to take care of the data transfer between the memory and USB-OTG FIFO. The USB-OTG core also supports USB power saving functions.

The USB2.0 OTG controller has following features:

- Complies with USB 2.0 Specification
- Support High-Speed (HS, 480-Mbps), Full-Speed (FS, 12-Mbps),and Low-Speed(LS,1.5-Mbps) in Host mode and support High-Speed(HS,480-Mbps),Full-Speed(FS,12-Mbps) in device mode
- Supports bi-directional endpoint0 for Control transfer
- Supports up to 10 User-Configurable Endpoints for Bulk , Isochronous and Interrupt bi-directional transfers (Endpoint1, Endpoint2, Endpoint3, Endpoint4, Endpoint5)
- Supports up to 8KB FIFO for EPs
- Support High-bandwidth Isochronous & Interrupt transfers
- Automated splitting/combining of packets for Bulk transfers
- Supports point-to-point and point-to-multipoint transfer in both Host and Peripheral mode
- Include automatic ping capabilities
- Soft connect/disconnect function
- Performs all transaction scheduling in hardware
- Supports the UTMI+ Level 3 interface . The 8-bit bidirectional data buses are used
- Supports point-to-point and point-to-multipoint transfer in both Host and Peripheral mode
- Power Optimization and Power Management capabilities
- Include interface to an external Normal DMA controller for every EPs

7.5.3. USB Host

7.5.3.1. Overview

USB Host Controller is fully compliant with the USB 2.0 specification, Enhanced Host Controller Interface (EHCI) Specification, Revision 1.0, and the Open Host Controller Interface (OHCI) Specification Release 1.0a. The controller supports high-speed, 480-Mbps transfers (40 times faster than USB 1.1 full-speed mode) using an EHCI Host Controller, as well as full and low speeds through one or more integrated OHCI Host Controllers.

The USB host controller includes the following features:

- Supports industry-standard AMBA High-Performance Bus (AHB) and it is fully compliant with the AMBA Specification, Revision 2.0.
- Supports 32-bit Little Endian AMBA AHB Slave Bus for Register Access.
- Supports 32-bit Little Endian AMBA AHB Master Bus for Memory Access.
- Including an internal DMA Controller for data transfer with memory.
- Complies with Enhanced Host Controller Interface (EHCI) Specification, Version 1.0, and the Open Host Controller Interface (OHCI) Specification, Version 1.0a.
- Supports High-Speed (HS, 480-Mbps), Full-Speed (FS, 12-Mbps), and Low-Speed (LS, 1.5-Mbps) Device.
- Supports the UTMI+ Level 3 interface . The 8-bit bidirectional data buses are used.
- Supports only 1 USB Root Port shared between EHCI and OHCI.

7.5.3.2. USB Host Timing Diagram

Please refer USB2.0 Specification, Enhanced Host Controller Interface (EHCI) Specification, Version 1.0, and the Open Host Controller Interface (OHCI) Specification, Version 1.0a.

7.5.3.3. USB Host Register List

Module Name	Base Address
USB_HCI1	0x01C1B000

Register Name	Offset	Description
EHCI Capability Register		
E_CAPLENGTH	0x000	EHCI Capability register Length Register
E_HCIVERSION	0x002	EHCI Host Interface Version Number Register
E_HCSPARAMS	0x004	EHCI Host Control Structural Parameter Register
E_HCCPARAMS	0x008	EHCI Host Control Capability Parameter Register
E_HCSPPORTROUTE	0x00c	EHCI Companion Port Route Description
EHCI Operational Register		
E_USBCMD	0x010	EHCI USB Command Register
E_USBSTS	0x014	EHCI USB Status Register
E_USBINTR	0x018	EHCI USB Interrupt Enable Register
E_FRINDEX	0x01c	EHCI USB Frame Index Register
E_CTRLDSSEGMENT	0x020	EHCI 4G Segment Selector Register
E_PERIODICLISTBASE	0x024	EHCI Frame List Base Address Register
E_ASYNC_LISTADDR	0x028	EHCI Next Asynchronous List Address Register
E_CONFIGFLAG	0x050	EHCI Configured Flag Register
E_PORTSC	0x054	EHCI Port Status/Control Register
OHCI Control and Status Partition Register		
O_HcRevision	0x400	OHCI Revision Register

O_HcControl	0x404	OHCI Control Register
O_HcCommandStatus	0x408	OHCI Command Status Register
O_HcInterruptStatus	0x40c	OHCI Interrupt Status Register
O_HcInterruptEnable	0x410	OHCI Interrupt Enable Register
O_HcInterruptDisable	0x414	OHCI Interrupt Disable Register
OHCI Memory Pointer Partition Register		
O_HcHCCA	0x418	OHCI HCCA Base
O_HcPeriodCurrentED	0x41c	OHCI Period Current ED Base
O_HcControlHeadED	0x420	OHCI Control Head ED Base
O_HcControlCurrentED	0x424	OHCI Control Current ED Base
O_HcBulkHeadED	0x428	OHCI Bulk Head ED Base
O_HcBulkCurrentED	0x42c	OHCI Bulk Current ED Base
O_HcDoneHead	0x430	OHCI Done Head Base
OHCI Frame Counter Partition Register		
O_HcFmInterval	0x434	OHCI Frame Interval Register
O_HcFmRemaining	0x438	OHCI Frame Remaining Register
O_HcFmNumber	0x43c	OHCI Frame Number Register
O_HcPeriodicStart	0x440	OHCI Periodic Start Register
O_HcLSThreshold	0x444	OHCI LS Threshold Register
OHCI Root Hub Partition Register		
O_HcRhDescriptorA	0x448	OHCI Root Hub Descriptor Register A
O_HcRhDescriptorB	0x44c	OHCI Root Hub Descriptor Register B
O_HcRhStatus	0x450	OHCI Root Hub Status Register
O_HcRhPortStatus	0x454	OHCI Root Hub Port Status Register

7.5.3.4. EHCI Register Description

7.5.3.4.1. EHCI Identification Register(Default Value: Implementation Dependent)

Offset: 0x0000			Register Name: CAPLENGTH
Bit	R/W	Default/Hex	Description
7:0	R	0x10	CAPLENGTH The value in these bits indicates an offset to add to register base to find the beginning of the Operational Register Space.

7.5.3.4.2. EHCI Host Interface Version Number Register(Default Value: 0x0100)

Offset: 0x0002			Register Name: HCIVERSION
Bit	R/W	Default/Hex	Description
15:0	R	0x0100	HCIVERSION

			This is a 16-bits register containing a BCD encoding of the EHCI revision number supported by this host controller. The most significant byte of this register represents a major revision and the least significant byte is the minor revision.
--	--	--	--

7.5.3.4.3. EHCI Host Control Structural Parameter Register(Default Value: Implementation Dependent)

Offset: 0x0004			Register Name: HCSPARAMS						
Bit	R/W	Default/Hex	Description						
31:24	/	0	Reserved. These bits are reserved and should be set to zero.						
23:20	R	0	Debug Port Number This register identifies which of the host controller ports is the debug port. The value is the port number (one based) of the debug port. This field will always be '0'.						
19:16	/	0	Reserved. These bits are reserved and should be set to zero.						
15:12	R	0	Number of Companion Controller (N_CC) This field indicates the number of companion controllers associated with this USB2.0 host controller. A zero in this field indicates there are no companion host controllers. And a value larger than zero in this field indicates there are companion USB1.1 host controller(s). This field will always be '0'.						
11:8	R	0	Number of Port per Companion Controller(N_PCC) This field indicates the number of ports supported per companion host controller host controller. It is used to indicate the port routing configuration to system software. This field will always fix with '0'.						
7	R	0	Port Routing Rules This field indicates the method used by this implementation for how all ports are mapped to companion controllers. The value of this field has the following interpretation: <table border="1" data-bbox="603 1585 1398 1883"> <thead> <tr> <th>Value</th> <th>Meaning</th> </tr> </thead> <tbody> <tr> <td>0</td> <td>The first N_PCC ports are routed to the lowest numbered function companion host controller, the next N_PCC port are routed to the next lowest function companion controller, and so on.</td> </tr> <tr> <td>1</td> <td>The port routing is explicitly enumerated by the first N_PORTS elements of the HCSP-PORTTOUTE array.</td> </tr> </tbody> </table> This field will always be '0'.	Value	Meaning	0	The first N_PCC ports are routed to the lowest numbered function companion host controller, the next N_PCC port are routed to the next lowest function companion controller, and so on.	1	The port routing is explicitly enumerated by the first N_PORTS elements of the HCSP-PORTTOUTE array.
Value	Meaning								
0	The first N_PCC ports are routed to the lowest numbered function companion host controller, the next N_PCC port are routed to the next lowest function companion controller, and so on.								
1	The port routing is explicitly enumerated by the first N_PORTS elements of the HCSP-PORTTOUTE array.								
6:4	/	0	Reserved. These bits are reserved and should be set to zero.						

3:0	R	1	<p>N_PORTS This field specifies the number of physical downstream ports implemented on this host controller. The value of this field determines how many port registers are addressable in the Operational Register Space. Valid values are in the range of 0x1 to 0x0f. This field is always 1.</p>
-----	---	---	---

7.5.3.4.4. EHCI Host Control Capability Parameter Register(Default Value: Implementation Dependent)

Offset: 0x0008			Register Name: HCCPARAMS
Bit	R/W	Default/Hex	Description
31:16	/	0	<p>Reserved These bits are reserved and should be set to zero.</p>
15:18	R	0	<p>EHCI Extended Capabilities Pointer (EECP) This optional field indicates the existence of a capabilities list. A value of 00b indicates no extended capabilities are implemented. A non-zero value in this register indicates the offset in PCI configuration space of the first EHCI extended capability. The pointer value must be 40h or greater if implemented to maintain consistency of the PCI header defined for this class of device. The value of this field is always '00b'.</p>
7:4	R		<p>Isochronous Scheduling Threshold This field indicates, relative to the current position of the executing host controller, where software can reliably update the isochronous schedule. When bit[7] is zero, the value of the least significant 3 bits indicates the number of micro-frames a host controller can hold a set of isochronous data structures(one or more) before flushing the state. When bit[7] is a one, then host software assumes the host controller may cache an isochronous data structure for an entire frame.</p>
3	R	0	<p>Reserved These bits are reserved and should be set to zero.</p>
2	R		<p>Asynchronous Schedule Park Capability If this bit is set to a one, then the host controller supports the park feature for high-speed queue heads in the Asynchronous Schedule. The feature can be disabled or enabled and set to a specific level by using the Asynchronous Schedule Park Mode Enable and Asynchronous Schedule Park Mode Count fields in the USBCMD register.</p>
1	R		<p>Programmable Frame List Flag If this bit is set to a zero, then system software must use a frame list length of 1024 elements with this host controller.The USBCMD register Frame List Size field is a read-only register and should be set to zero. If set to 1,then system software can specify and use the frame list in the USBCMD register Frame List Size field to configure the host controller.</p>

			The frame list must always aligned on a 4K page boundary.This requirement ensures that the frame list is always physically contiguous.
0	R	0	Reserved These bits are reserved for future use and should return a value of zero when read.

7.5.3.4.5. EHCI Companion Port Route Description (Default Value: UNDEFINED)

Offset: 0x000C			Register Name: HCSP-PORTROUTE
Bit	R/W	Default/Hex	Description
31:0	R		<p>HCSP-PORTROUTE</p> <p>This optional field is valid only if Port Routing Rules field in HCSPARAMS register is set to a one.</p> <p>This field is used to allow a host controller implementation to explicitly describe to which companion host controller each implemented port is mapped. This field is a 15-element nibble array (each 4 bit is one array element). Each array location corresponds one-to-one with a physical port provided by the host controller (e.g. PORTROUTE [0] corresponds to the first PORTSC port, PORTROUTE [1] to the second PORTSC port, etc.). The value of each element indicates to which of the companion host controllers this port is routed. Only the first N_PORTS elements have valid information. A value of zero indicates that the port is routed to the lowest numbered function companion host controller. A value of one indicates that the port is routed to the next lowest numbered function companion host controller, and so on.</p>

7.5.3.4.6. EHCI USB Command Register (Default Value: 0x00080000,0x00080B00 if Asynchronous Schedule Park Capability is a one)

Offset: 0x0010			Register Name: USBCMD						
Bit	R/W	Default/Hex	Description						
31:24	/	0	Reserved These bits are reserved and should be set to zero.						
23:16	R/W	0x08	<p>Interrupt Threshold Control</p> <p>The value in this field is used by system software to select the maximum rate at which the host controller will issue interrupts. The only valid values are defined below:</p> <table border="1" data-bbox="598 1870 1428 2004"> <tr> <th>Value</th> <th>Minimum Interrupt Interval</th> </tr> <tr> <td>0x00</td> <td>Reserved</td> </tr> <tr> <td>0x01</td> <td>1 micro-frame</td> </tr> </table>	Value	Minimum Interrupt Interval	0x00	Reserved	0x01	1 micro-frame
Value	Minimum Interrupt Interval								
0x00	Reserved								
0x01	1 micro-frame								

			<table border="1"> <tr> <td>0x02</td> <td>2 micro-frame</td> </tr> <tr> <td>0x04</td> <td>4 micro-frame</td> </tr> <tr> <td>0x08</td> <td>8 micro-frame(default, equates to 1 ms)</td> </tr> <tr> <td>0x10</td> <td>16 micro-frame(2ms)</td> </tr> <tr> <td>0x20</td> <td>32 micro-frame(4ms)</td> </tr> <tr> <td>0x40</td> <td>64 micro-frame(8ms)</td> </tr> </table> <p>Any other value in this register yields undefined results. The default value in this field is 0x08 . Software modifications to this bit while HC Halted bit is equal to zero results in undefined behavior.</p>	0x02	2 micro-frame	0x04	4 micro-frame	0x08	8 micro-frame(default, equates to 1 ms)	0x10	16 micro-frame(2ms)	0x20	32 micro-frame(4ms)	0x40	64 micro-frame(8ms)
0x02	2 micro-frame														
0x04	4 micro-frame														
0x08	8 micro-frame(default, equates to 1 ms)														
0x10	16 micro-frame(2ms)														
0x20	32 micro-frame(4ms)														
0x40	64 micro-frame(8ms)														
15:12	/	0	Reserved These bits are reserved and should be set to zero.												
11	R/W or R	0	Asynchronous Schedule Park Mode Enable(OPTIONAL) If the Asynchronous Park Capability bit in the HCCPARAMS register is a one, then this bit defaults to a 1 and is R/W. Otherwise the bit must be a zero and is Read Only. Software uses this bit to enable or disable Park mode. When this bit is one, Park mode is enabled. When this bit is zero, Park mode is disabled.												
10	/	0	Reserved These bits are reserved and should be set to zero.												
9:8	R/W or R	0	Asynchronous Schedule Park Mode Count(OPTIONAL) Asynchronous Park Capability bit in the HCCPARAMS register is a one, Then this field defaults to 0x3 and is W/R. Otherwise it defaults to zero and is R. It contains a count of the number of successive transactions the host controller is allowed to execute from a high-speed queue head on the Asynchronous schedule before continuing traversal of the Asynchronous schedule. Valid value are 0x1 to 0x3. Software must not write a zero to this bit when Park Mode Enable is a one as it will result in undefined behavior.												
7	R/W	0	Light Host Controller Reset(OPTIONAL) This control bit is not required. If implemented, it allows the driver to reset the EHCI controller without affecting the state of the ports or relationship to the companion host controllers. For example, the PORSTC registers should not be reset to their default values and the CF bit setting should not go to zero (retaining port ownership relationships). A host software read of this bit as zero indicates the Light Host Controller Reset has completed and it is safe for software to re-initialize the host controller. A host software read of this bit as a one indicates the Light Host												
6	R/W	0	Interrupt on Async Advance Doorbell This bit is used as a doorbell by software to tell the host controller to issue an interrupt the next time it advances asynchronous schedule. Software must write a 1 to this bit to ring the doorbell.												

			<p>When the host controller has evicted all appropriate cached schedule state, it sets the Interrupt on Async Advance status bit in the USBSTS. if the Interrupt on Async Advance Enable bit in the USBINTR register is a one then the host controller will assert an interrupt at the next interrupt threshold.</p> <p>The host controller sets this bit to a zero after it has set the Interrupt on Async Advance status bit in the USBSTS register to a one.</p> <p>Software should not write a one to this bit when the asynchronous schedule is disabled. Doing so will yield undefined results.</p>										
5	R/W	0	<p>Asynchronous Schedule Enable</p> <p>This bit controls whether the host controller skips processing the Asynchronous Schedule. Values mean:</p> <table border="1"> <thead> <tr> <th>Bit Value</th> <th>Meaning</th> </tr> </thead> <tbody> <tr> <td>0</td> <td>Do not process the Asynchronous Schedule.</td> </tr> <tr> <td>1</td> <td>Use the ASYNLISTADDR register to access the Asynchronous Schedule.</td> </tr> </tbody> </table> <p>The default value of this field is '0b'.</p>	Bit Value	Meaning	0	Do not process the Asynchronous Schedule.	1	Use the ASYNLISTADDR register to access the Asynchronous Schedule.				
Bit Value	Meaning												
0	Do not process the Asynchronous Schedule.												
1	Use the ASYNLISTADDR register to access the Asynchronous Schedule.												
4	R/W	0	<p>Periodic Schedule Enable</p> <p>This bit controls whether the host controller skips processing the Periodic Schedule. Values mean:</p> <table border="1"> <thead> <tr> <th>Bit Value</th> <th>Meaning</th> </tr> </thead> <tbody> <tr> <td>0</td> <td>Do not process the Periodic Schedule.</td> </tr> <tr> <td>1</td> <td>Use the PERIODICLISTBASE register to access the Periodic Schedule.</td> </tr> </tbody> </table> <p>The default value of this field is '0b'.</p>	Bit Value	Meaning	0	Do not process the Periodic Schedule.	1	Use the PERIODICLISTBASE register to access the Periodic Schedule.				
Bit Value	Meaning												
0	Do not process the Periodic Schedule.												
1	Use the PERIODICLISTBASE register to access the Periodic Schedule.												
3:2	R/W or R	0	<p>Frame List Size</p> <p>This field is R/W only if Programmable Frame List Flag in the HCCPARAMS registers is set to a one. This field specifies the size of the Frame list. The size the frame list controls which bits in the Frame Index Register should be used for the Frame List Current index. Values mean:</p> <table border="1"> <thead> <tr> <th>Bits</th> <th>Meaning</th> </tr> </thead> <tbody> <tr> <td>00b</td> <td>1024 elements(4096bytes)Default</td> </tr> <tr> <td>01b</td> <td>512 elements(2048byts)</td> </tr> <tr> <td>10b</td> <td>256 elements(1024bytes)For resource-constrained condition</td> </tr> <tr> <td>11b</td> <td>reserved</td> </tr> </tbody> </table> <p>The default value is '00b'.</p>	Bits	Meaning	00b	1024 elements(4096bytes)Default	01b	512 elements(2048byts)	10b	256 elements(1024bytes)For resource-constrained condition	11b	reserved
Bits	Meaning												
00b	1024 elements(4096bytes)Default												
01b	512 elements(2048byts)												
10b	256 elements(1024bytes)For resource-constrained condition												
11b	reserved												
1	R/W	0	<p>Host Controller Reset</p> <p>This control bit is used by software to reset the host controller. The effects of this on Root Hub registers are similar to a Chip Hardware Reset. When software writes a one to this bit, the Host Controller resets its internal pipelines, timers, counters, state machines, etc. to their initial value. Any transaction currently in progress on USB is immediately terminated. A USB reset is not driven on downstream ports.</p>										

			<p>All operational registers, including port registers and port state machines are set to their initial values. Port ownership reverts to the companion host controller(s). Software must reinitialize the host controller as described in Section 4.1 of the CHEI Specification in order to return the host controller to an operational state.</p> <p>This bit is set to zero by the Host Controller when the reset process is complete. Software cannot terminate the reset process early by writing a zero to this register.</p> <p>Software should not set this bit to a one when the HC Halted bit in the USBSTS register is a zero. Attempting to reset an actively running host controller will result in undefined behavior.</p>
0	R/W	0	<p>Run/Stop</p> <p>When set to a 1, the Host Controller proceeds with execution of the schedule. When set to 0, the Host Controller completes the current and any actively pipelined transactions on the USB and then halts. The Host Controller must halt within 16 micro-frames after software clears this bit. The HC Halted bit indicates when the Host Controller has finished its pending pipelined transactions and has entered the stopped state. Software must not write a one to this field unless the Host Controller is in the Halt State.</p> <p>The default value is 0x0.</p>

7.5.3.4.7. EHCI USB Status Register (Default Value: 0x00001000)

Offset: 0x0014			Register Name: USBSTS
Bit	R/W	Default/Hex	Description
31:16	/	0	<p>Reserved</p> <p>These bits are reserved and should be set to zero.</p>
15	R	0	<p>Asynchronous Schedule Status</p> <p>The bit reports the current real status of Asynchronous Schedule. If this bit is a zero then the status of the Asynchronous Schedule is disabled. If this bit is a one then the status of the Asynchronous Schedule is enabled. The Host Controller is not required to immediately disable or enable the Asynchronous Schedule when software transitions the Asynchronous Schedule Enable bit in the USBCMD register. When this bit and the Asynchronous Schedule Enable bit are the same value, the Asynchronous Schedule is either enabled (1) or disabled (0).</p>
14	R	0	<p>Periodic Schedule Status</p> <p>The bit reports the current real status of the Periodic Schedule. If this bit is a zero then the status of the Periodic Schedule is disabled. If this bit is a one then the status of the Periodic Schedule is enabled. The Host Controller is not required to immediately disable or enable the Periodic Schedule when software transitions the Periodic Schedule Enable bit in</p>

			the USBCMD register. When this bit and the Periodic Schedule Enable bit are the same value, the Periodic Schedule is either enabled (1) or disabled (0).
13	R	0	<p>Reclamation</p> <p>This is a read-only status bit, which is used to detect an empty asynchronous schedule.</p>
12	R	1	<p>HC Halted</p> <p>This bit is a zero whenever the Run/Stop bit is a one. The Host Controller Sets this bit to one after it has stopped executing as a result of the Run/Stop bit being set to 0, either by software or by the Host Controller Hardware (e.g. internal error).</p> <p>The default value is '1'.</p>
11:6	/	0	<p>Reserved</p> <p>These bits are reserved and should be set to zero.</p>
5	R/WC	0	<p>Interrupt on Async Advance</p> <p>System software can force the host controller to issue an interrupt the next time the host controller advances the asynchronous schedule by writing a one to the Interrupt on Async Advance Doorbell bit in the USBCMD register. This status bit indicates the assertion of that interrupt source.</p>
4	R/WC	0	<p>Host System Error</p> <p>The Host Controller set this bit to 1 when a serious error occurs during a host system access involving the Host Controller module. When this error occurs, the Host Controller clears the Run/Stop bit in the Command register to prevent further execution of the scheduled TDs.</p>
3	R/WC	0	<p>Frame List Rollover</p> <p>The Host Controller sets this bit to a one when the Frame List Index rolls over from its maximum value to zero. The exact value at which the rollover occurs depends on the frame list size. For example, if the frame list size is 1024, the Frame Index Register rolls over every time FRINDEX [13] toggles. Similarly, if the size is 512, the Host Controller sets this bit to a one every time FRINDEX [12] toggles.</p>
2	R/WC	0	<p>Port Change Detect</p> <p>The Host Controller sets this bit to a one when any port for which the Port Owner bit is set to zero has a change bit transition from a zero to a one or a Force Port Resume bit transition from a zero to a one as a result of a J-K transition detected on a suspended port. This bit will also be set as a result of the Connect Status Chang being set to a one after system software has relinquished ownership of a connected port by writing a one to a port's Port Owner bit.</p>
1	R/WC	0	<p>USB Error Interrupt(USBERRINT)</p> <p>The Host Controller sets this bit to 1 when completion of USB transaction results in an error condition(e.g. error counter underflow).If the TD on which the error interrupt occurred also had its IOC bit set, both.</p>

			This bit and USBINT bit are set.
0	R/WC	0	<p>USB Interrupt(USBINT)</p> <p>The Host Controller sets this bit to a one on the completion of a USB transaction, which results in the retirement of a Transfer Descriptor that had its IOC bit set.</p> <p>The Host Controller also sets this bit to 1 when a short packet is detected (actual number of bytes received was less than the expected number of bytes)</p>

7.5.3.4.8. EHCI USB Interrupt Enable Register (Default Value: 0x00000000)

Offset: 0x0018			Register Name: USBINTR
Bit	R/W	Default/Hex	Description
31:6	/	0	<p>Reserved</p> <p>These bits are reserved and should be zero.</p>
5	R/W	0	<p>Interrupt on Async Advance Enable</p> <p>When this bit is 1, and the Interrupt on Async Advance bit in the USBSTS register is 1, the host controller will issue an interrupt at the next interrupt threshold. The interrupt is acknowledged by software clearing the Interrupt on Async Advance bit.</p>
4	R/W	0	<p>Host System Error Enable</p> <p>When this bit is 1, and the Host System Error Status bit in the USBSTS register is 1, the host controller will issue an interrupt. The interrupt is acknowledged by software clearing the Host System Error bit.</p>
3	R/W	0	<p>Frame List Rollover Enable</p> <p>When this bit is 1, and the Frame List Rollover bit in the USBSTS register is 1, the host controller will issue an interrupt. The interrupt is acknowledged by software clearing the Frame List Rollover bit.</p>
2	R/W	0	<p>Port Change Interrupt Enable</p> <p>When this bit is 1, and the Port Chang Detect bit in the USBSTS register is 1, the host controller will issue an interrupt. The interrupt is acknowledged by software clearing the Port Chang Detect bit.</p>
1	R/W	0	<p>USB Error Interrupt Enable</p> <p>When this bit is 1, and the USBERRINT bit in the USBSTS register is 1,the host controller will issue an interrupt at the next interrupt threshold. The interrupt is acknowledged by software clearing the USBERRINT bit.</p>
0	R/W	0	<p>USB Interrupt Enable</p> <p>When this bit is 1, and the USBINT bit in the USBSTS register is 1,the host controller will issue an interrupt at the next interrupt threshold. The interrupt is acknowledged by software clearing the USBINT bit</p>

7.5.3.4.9. EHCI Frame Index Register (Default Value: 0x00000000)

Offset: 0x001C			Register Name: FRINDEX															
Bit	R/W	Default/Hex	Description															
31:14	/	0	Reserved These bits are reserved and should be zero.															
13:0	R/W	0	<p>Frame Index The value in this register increment at the end of each time frame (e.g. micro-frame). Bits[N:3] are used for the Frame List current index. It Means that each location of the frame list is accessed 8 times(frames or Micro-frames) before moving to the next index. The following illustrates Values of N based on the value of the Frame List Size field in the USBCMD register.</p> <table border="1" style="width: 100%; border-collapse: collapse;"> <thead> <tr> <th>USBCMD[Frame List Size]</th> <th>Number Elements</th> <th>N</th> </tr> </thead> <tbody> <tr> <td>00b</td> <td>1024</td> <td>12</td> </tr> <tr> <td>01b</td> <td>512</td> <td>11</td> </tr> <tr> <td>10b</td> <td>256</td> <td>10</td> </tr> <tr> <td>11b</td> <td>Reserved</td> <td></td> </tr> </tbody> </table>	USBCMD[Frame List Size]	Number Elements	N	00b	1024	12	01b	512	11	10b	256	10	11b	Reserved	
USBCMD[Frame List Size]	Number Elements	N																
00b	1024	12																
01b	512	11																
10b	256	10																
11b	Reserved																	

Note: This register must be written as a DWord. Byte writes produce undefined results.

7.5.3.4.10. EHCI Periodic Frame List Base Address Register (Default Value: Undefined)

Offset: 0x0024			Register Name: PERIODICLISTBASE
Bit	R/W	Default/Hex	Description
31:12	R/W		<p>Base Address These bits correspond to memory address signals [31:12], respectively. This register contains the beginning address of the Periodic Frame List in the system memory. System software loads this register prior to starting the schedule execution by the Host Controller. The memory structure referenced by this physical memory pointer is assumed to be 4-K byte aligned. The contents of this register are combined with the Frame Index Register (FRINDEX) to enable the Host Controller to step through the Periodic Frame List in sequence.</p>
11:0	/		<p>Reserved Must be written as 0x0 during runtime, the values of these bits are undefined.</p>

Note: Writes must be Dword Writes.

7.5.3.4.11. EHCI Current Asynchronous List Address Register (Default Value: Undefined)

Offset: 0x0028			Register Name: ASYNCLISTADDR
Bit	R/W	Default/Hex	Description
31:5	R/W	/	Link Pointer (LP) This field contains the address of the next asynchronous queue head to be executed. These bits correspond to memory address signals [31:5], respectively.
4:0	/	/	Reserved These bits are reserved and their value has no effect on operation. Bits in this field cannot be modified by system software and will always return a zero when read.

Note: Write must be DWord Writes.

7.5.3.4.12. EHCI Configure Flag Register (Default Value: 0x00000000)

Offset: 0x0050			Register Name: CONFIGFLAG						
Bit	R/W	Default/Hex	Description						
31:1	/	0	Reserved These bits are reserved and should be set to zero.						
0	R/W	0	Configure Flag(CF) Host software sets this bit as the last action in its process of configuring the Host Controller. This bit controls the default port-routing control logic as follow: <table border="1" style="width: 100%; border-collapse: collapse;"> <thead> <tr> <th>Value</th> <th>Meaning</th> </tr> </thead> <tbody> <tr> <td>0</td> <td>Port routing control logic default-routs each port to an implementation dependent classic host controller.</td> </tr> <tr> <td>1</td> <td>Port routing control logic default-routs all ports to this host controller.</td> </tr> </tbody> </table> The default value of this field is '0'.	Value	Meaning	0	Port routing control logic default-routs each port to an implementation dependent classic host controller.	1	Port routing control logic default-routs all ports to this host controller.
Value	Meaning								
0	Port routing control logic default-routs each port to an implementation dependent classic host controller.								
1	Port routing control logic default-routs all ports to this host controller.								

Note: This register is not use in the normal implementation.

7.5.3.4.13. EHCI Port Status and Control Register (Default Value: 0x00002000(w/PPC set to one);0x00003000(w/PPC set to a zero))

Offset: 0x0054			Register Name: PORTSC
Bit	R/W	Default/Hex	Description
31:22	/	0	Reserved

			These bits are reserved for future use and should return a value of zero when read.																
21	R/W	0	<p>Wake on Disconnect Enable(WKDSCNNT_E) Writing this bit to a one enables the port to be sensitive to device disconnects as wake-up events. This field is zero if Port Power is zero. The default value in this field is '0'.</p>																
20	R/W	0	<p>Wake on Connect Enable(WKCNNT_E) Writing this bit to a one enable the port to be sensitive to device connects as wake-up events. This field is zero if Port Power is zero. The default value in this field is '0'.</p>																
19:16	R/W	0	<p>Port Test Control The value in this field specifies the test mode of the port. The encoding of the test mode bits are as follow:</p> <table border="1" style="margin-left: 20px;"> <thead> <tr> <th>Bits</th> <th>Test Mode</th> </tr> </thead> <tbody> <tr> <td>0000b</td> <td>The port is NOT operating in a test mode.</td> </tr> <tr> <td>0001b</td> <td>Test J_STATE</td> </tr> <tr> <td>0010b</td> <td>Test K_STATE</td> </tr> <tr> <td>0011b</td> <td>Test SEO_NAK</td> </tr> <tr> <td>0100b</td> <td>Test Packet</td> </tr> <tr> <td>0101b</td> <td>Test FORCE_ENABLE</td> </tr> <tr> <td>0110b-1111b</td> <td>Reserved</td> </tr> </tbody> </table> <p>The default value in this field is '0000b'.</p>	Bits	Test Mode	0000b	The port is NOT operating in a test mode.	0001b	Test J_STATE	0010b	Test K_STATE	0011b	Test SEO_NAK	0100b	Test Packet	0101b	Test FORCE_ENABLE	0110b-1111b	Reserved
Bits	Test Mode																		
0000b	The port is NOT operating in a test mode.																		
0001b	Test J_STATE																		
0010b	Test K_STATE																		
0011b	Test SEO_NAK																		
0100b	Test Packet																		
0101b	Test FORCE_ENABLE																		
0110b-1111b	Reserved																		
15:14	R/W	0	<p>Reserved These bits are reserved for future use and should return a value of zero when read.</p>																
13	R/W	1	<p>Port Owner This bit unconditionally goes to a 0b when the Configured bit in the CONFIGFLAG register makes a 0b to 1b transition. This bit unconditionally goes to 1b whenever the Configured bit is zero. System software uses this field to release ownership of the port to selected host controller (in the event that the attached device is not a high-speed device).Software writes a one to this bit when the attached device is not a high-speed device. A one in this bit means that a companion host controller owns and controls the port. Default Value = 1b.</p>																
12	/	0	<p>Reserved These bits are reserved for future use and should return a value of zero when read.</p>																
11:10	R	0	<p>Line Status These bits reflect the current logical levels of the D+ (bit11) and D-(bit10)</p>																

			<p>signal lines. These bits are used for detection of low-speed USB devices prior to port reset and enable sequence. This read only field is valid only when the port enable bit is zero and the current connect status bit is set to a one.</p> <p>The encoding of the bits are:</p> <table border="1"> <thead> <tr> <th>Bit[11:10]</th> <th>USB State</th> <th>Interpretation</th> </tr> </thead> <tbody> <tr> <td>00b</td> <td>SE0</td> <td>Not Low-speed device, perform EHCI reset.</td> </tr> <tr> <td>10b</td> <td>J-state</td> <td>Not Low-speed device, perform EHCI reset.</td> </tr> <tr> <td>01b</td> <td>K-state</td> <td>Low-speed device, release ownership of port.</td> </tr> <tr> <td>11b</td> <td>Undefined</td> <td>Not Low-speed device, perform EHCI reset.</td> </tr> </tbody> </table> <p>This value of this field is undefined if Port Power is zero.</p>	Bit[11:10]	USB State	Interpretation	00b	SE0	Not Low-speed device, perform EHCI reset.	10b	J-state	Not Low-speed device, perform EHCI reset.	01b	K-state	Low-speed device, release ownership of port.	11b	Undefined	Not Low-speed device, perform EHCI reset.
Bit[11:10]	USB State	Interpretation																
00b	SE0	Not Low-speed device, perform EHCI reset.																
10b	J-state	Not Low-speed device, perform EHCI reset.																
01b	K-state	Low-speed device, release ownership of port.																
11b	Undefined	Not Low-speed device, perform EHCI reset.																
9	/	0	<p>Reserved</p> <p>This bit is reserved for future use, and should return a value of zero when read.</p>															
8	R/W	0	<p>Port Reset</p> <p>1=Port is in Reset. 0=Port is not in Reset. Default = 0.</p> <p>When software writes a one to this bit (from a zero), the bus reset sequence as defined in the USB Specification Revision 2.0 is started. Software writes a zero to this bit to terminate the bus reset sequence. Software must keep this bit at a one long enough to ensure the reset sequence, as specified in the USB Specification Revision 2.0, completes.</p> <p>Notes: when software writes this bit to a one , it must also write a zero to the Port Enable bit.</p> <p>Note that when software writes a zero to this bit there may be a delay before the bit status changes to a zero. The bit status will not read as a zero until after the reset has completed. If the port is in high-speed mode after reset is complete, the host controller will automatically enable this port (e.g. set the Port Enable bit to a one). A host controller must terminate the reset and stabilize the state of the port within 2 milliseconds of software transitioning this bit from a one to a zero. For example: if the port detects that the attached device is high-speed during reset, then the host controller must have the port in the enabled state with 2ms of software writing this bit to a zero.</p> <p>The HC Halted bit in the USBSTS register should be a zero before software attempts to use this bit. The host controller may hold Port Reset asserted to a one when the HC Halted bit is a one.</p> <p>This field is zero if Port Power is zero.</p>															
7	R/W	0	<p>Suspend</p> <p>Port Enabled Bit and Suspend bit of this register define the port states as follows:</p>															

			<table border="1"> <thead> <tr> <th>Bits[Port Enables, Suspend]</th> <th>Port State</th> </tr> </thead> <tbody> <tr> <td>0x</td> <td>Disable</td> </tr> <tr> <td>10</td> <td>Enable</td> </tr> <tr> <td>11</td> <td>Suspend</td> </tr> </tbody> </table> <p>When in suspend state, downstream propagation of data is blocked on this port, except for port reset. The blocking occurs at the end of the current transaction, if a transaction was in progress when this bit was written to 1. In the suspend state, the port is sensitive to resume detection. Not that the bit status does not change until the port is suspend and that there may be a delay in suspending a port if there is a transaction currently in progress on the USB.</p> <p>A write of zero to this bit is ignored by the host controller. The host controller will unconditionally set this bit to a zero when:</p> <ol style="list-style-type: none"> ① Software sets the Force Port Resume bit to a zero(from a one). ② Software sets the Port Reset bit to a one(from a zero). <p>If host software sets this bit to a one when the port is not enabled(i.e. Port enabled bit is a zero), the results are undefined.</p> <p>This field is zero if Port Power is zero.</p> <p>The default value in this field is '0'.</p>	Bits[Port Enables, Suspend]	Port State	0x	Disable	10	Enable	11	Suspend
Bits[Port Enables, Suspend]	Port State										
0x	Disable										
10	Enable										
11	Suspend										
6	R/W	0	<p>Force Port Resume</p> <p>1 = Resume detected/driven on port. 0 = No resume (K-state) detected/driven on port. Default = 0.</p> <p>This functionality defined for manipulating this bit depends on the value of the Suspend bit. For example, if the port is not suspend and software transitions this bit to a one, then the effects on the bus are undefined. Software sets this bit to a 1 drive resume signaling. The Host Controller sets this bit to a 1 if a J-to-K transition is detected while the port is in the Suspend state. When this bit transitions to a one because a J-to-K transition is detected, the Port Change Detect bit in the USBSTS register is also set to a one. If software sets this bit to a one, the host controller must not set the Port Change Detect bit.</p> <p>Note that when the EHCI controller owns the port, the resume sequence follows the defined sequence documented in the USB Specification Revision 2.0. The resume signaling (Full-speed 'K') is driven on the port as long as this remains a one. Software must appropriately time the Resume and set this bit to a zero when the appropriate amount of time has elapsed. Writing a zero (from one) causes the port to return high-speed mode (forcing the bus below the port into a high-speed idle). This bit will remain a one until the port has switched to high-speed idle. The host controller must complete this transition within 2 milliseconds of software setting this bit to a zero.</p> <p>This field is zero if Port Power is zero.</p>								
5	R/WC	0	<p>Over-current Change</p> <p>Default = 0. This bit gets set to a one when there is a change to</p>								

			Over-current Active. Software clears this bit by writing a one to this bit position.
4	R	0	Over-current Active 0 = This port does not have an over-current condition. 1 = This port currently has an over-current condition. This bit will automatically transition from a one to a zero when the over current condition is removed. The default value of this bit is '0'.
3	R/WC	0	Port Enable/Disable Change Default = 0. 1 = Port enabled/disabled status has changed. 0 = No change. For the root hub, this bit gets set to a one only when a port is disabled due to the appropriate conditions existing at the EOF2 point (See Chapter 11 of the USB Specification for the definition of a Port Error). Software clears this bit by writing a 1 to it. This field is zero if Port Power is zero.
2	R/W	0	Port Enabled/Disabled 1=Enable, 0=Disable. Ports can only be enabled by the host controller as a part of the reset and enable. Software cannot enable a port by writing a one to this field. The host controller will only set this bit to a one when the reset sequence determines that the attached device is a high-speed device. Ports can be disabled by either a fault condition(disconnect event or other fault condition) or by host software. Note that the bit status does not change until the port state actually changes. There may be a delay in disabling or enabling a port due to other host controller and bus events. When the port is disabled, downstream propagation of data is blocked on this port except for reset. The default value of this field is '0'. This field is zero if Port Power is zero.
1	R/WC	0	Connect Status Change 1=Change in Current Connect Status, 0=No change, Default=0. Indicates a change has occurred in the port's Current Connect Status. The host controller sets this bit for all changes to the port device connect status, even if system software has not cleared an existing connect status change. For example, the insertion status changes twice before system software has cleared the changed condition, hub hardware will be "setting" an already-set bit. Software sets this bit to 0 by writing a 1 to it. This field is zero if Port Power is zero.
0	R	0	Current Connect Status Device is present on port when the value of this field is a one, and no device is present on port when the value of this field is a zero. This value reflects the current state of the port, and may not correspond directly to the event that caused the Connect Status Change(Bit 1) to be set. This field is zero if Port Power zero.

Note: This register is only reset by hardware or in response to a host controller reset.

7.5.3.5. OHCI Register Description

7.5.3.5.1. HcRevision Register(Default Value: 0x00000010)

Offset: 0x400				Register Name: HcRevision
Bit	Read/Write		Default/Hex	Description
	HCD	HC		
31:8	/	/	0x00	Reserved
7:0	R	R	0x10	Revision This read-only field contains the BCD representation of the version of the HCI specification that is implemented by this HC. For example, a value of 0x11 corresponds to version 1.1. All of the HC implementations that are compliant with this specification will have a value of 0x10.

7.5.3.5.2. HcControl Register(Default Value: 0x00000000)

Offset: 0x404				Register Name: HcRevision
Bit	Read/Write		Default/Hex	Description
	HCD	HC		
31:11	/	/	0x00	Reserved
10	R/W	R	0x0	RemoteWakeupEnable This bit is used by HCD to enable or disable the remote wakeup feature upon the detection of upstream resume signaling. When this bit is set and the ResumeDetected bit in HcInterruptStatus is set, a remote wakeup is signaled to the host system. Setting this bit has no impact on the generation of hardware interrupt.
9	R/W	R/W	0x0	RemoteWakeupConnected This bit indicates whether HC supports remote wakeup signaling. If remote wakeup is supported and used by the system, it is the responsibility of system firmware to set this bit during POST. HC clear the bit upon a hardware reset but does not alter it upon a software reset. Remote wakeup signaling of the host system is host-bus-specific and is not described in this specification.
8	R/W	R	0x0	InterruptRouting This bit determines the routing of interrupts generated by events

				<p>registered in HcInterruptStatus. If clear, all interrupt are routed to the normal host bus interrupt mechanism. If set interrupts are routed to the System Management Interrupt. HCD clears this bit upon a hardware reset, but it does not alter this bit upon a software reset. HCD uses this bit as a tag to indicate the ownership of HC.</p>								
7:6	R/W	R/W	0x0	<p>HostControllerFunctionalState for USB</p> <table border="1"> <tr> <td>00b</td> <td>USBReset</td> </tr> <tr> <td>01b</td> <td>USBResume</td> </tr> <tr> <td>10b</td> <td>USBOperational</td> </tr> <tr> <td>11b</td> <td>USBSuspend</td> </tr> </table> <p>A transition to USBOperational from another state causes SOF generation to begin 1 ms later. HCD may determine whether HC has begun sending SOFs by reading the StartoFrame field of HcInterruptStatus.</p> <p>This field may be changed by HC only when in the USBSUSPEND state. HC may move from the USBSUSPEND state to the USBRESUME state after detecting the resume signaling from a downstream port. HC enters USBSUSPEND after a software reset, whereas it enters USBRESET after a hardware reset. The latter also resets the Root Hub and asserts subsequent reset signaling to downstream ports.</p>	00b	USBReset	01b	USBResume	10b	USBOperational	11b	USBSuspend
00b	USBReset											
01b	USBResume											
10b	USBOperational											
11b	USBSuspend											
5	R/W	R	0x0	<p>BulkListEnable</p> <p>This bit is set to enable the processing of the Bulk list in the next Frame. If cleared by HCD, processing of the Bulk list does not occur after the next SOF. HC checks this bit whenever it determines to process the list. When disabled, HCD may modify the list. If HcBulkCurrentED is pointing to an ED to be removed, HCD must advance the pointer by updating HcBulkCurrentED before re-enabling processing of the list.</p>								
4	R/W	R	0x0	<p>ControlListEnable</p> <p>This bit is set to enable the processing of the Control list in the next Frame. If cleared by HCD, processing of the Control list does not occur after the next SOF. HC must check this bit whenever it determines to process the list. When disabled, HCD may modify the list. If HcControlCurrentED is pointing to an ED to be removed, HCD must advance the pointer by updating HcControlCurrentED before re-enabling processing of the list.</p>								
3	R/W	R	0x0	<p>IsochronousEnable</p> <p>This bit is used by HCD to enable/disable processing of isochronous EDs. While processing the periodic list in a Frame, HC checks the status of this bit when it finds an Isochronous ED (F=1). If set (enabled), HC continues processing the EDs. If cleared (disabled), HC halts processing of the periodic list (which now contains only isochronous EDs) and begins processing the Bulk/Control lists.</p> <p>Setting this bit is guaranteed to take effect in the next Frame (not the current Frame).</p>								

2	R/W	R	0x0	<p>PeriodicListEnable</p> <p>This bit is set to enable the processing of periodic list in the next Frame. If cleared by HCD, processing of the periodic list does not occur after the next SOF. HC must check this bit before it starts processing the list.</p>										
1:0	R/W	R	0x0	<p>ControlBulkServiceRatio</p> <p>This specifies the service ratio between Control and Bulk EDs. Before processing any of the nonperiodic lists, HC must compare the ratio specified with its internal count on how many nonempty Control EDs have been processed, in determining whether to continue serving another Control ED or switching to Bulk EDs. The internal count will be retained when crossing the frame boundary. In case of reset, HCD is responsible for restoring this value.</p> <table border="1" data-bbox="619 689 1393 913"> <thead> <tr> <th>CBSR</th> <th>No. of Control EDs Over Bulk EDs Served</th> </tr> </thead> <tbody> <tr> <td>0</td> <td>1:1</td> </tr> <tr> <td>1</td> <td>2:1</td> </tr> <tr> <td>2</td> <td>3:1</td> </tr> <tr> <td>3</td> <td>4:1</td> </tr> </tbody> </table> <p>The default value is 0x0.</p>	CBSR	No. of Control EDs Over Bulk EDs Served	0	1:1	1	2:1	2	3:1	3	4:1
CBSR	No. of Control EDs Over Bulk EDs Served													
0	1:1													
1	2:1													
2	3:1													
3	4:1													

7.5.3.5.3. HcCommandStatus Register(Default Value: 0x00000000)

Offset: 0x408				Register Name: HcCommandStatus
Bit	Read/Write		Default/Hex	Description
	HCD	HC		
31:18	/	/	0x0	Reserved
17:16	R	R/W	0x0	<p>SchedulingOverrunCount</p> <p>These bits are incremented on each scheduling overrun error. It is initialized to 00b and wraps around at 11b. This will be incremented when a scheduling overrun is detected even if SchedulingOverrun in HcInterruptStatus has already been set. This is used by HCD to monitor any persistent scheduling problem.</p>
15:4	/	/	0x0	Reserved
3	R/W	R/W	0x0	<p>OwenshipChangeRequest</p> <p>This bit is set by an OS HCD to request a change of control of the HC. When set HC will set the OwnershipChange field in HcInterruptStatus. After the changeover, this bit is cleared and remains so until the next request from OS HCD.</p>
2	R/W	R/W	0x0	<p>BulkListFilled</p> <p>This bit is used to indicate whether there are any TDs on the Bulk list. It is set by HCD whenever it adds a TD to an ED in the Bulk list. When HC begins to process the head of the Bulk list, it checks BLF. As long as BulkListFilled is 0, HC will not start processing the Bulk list. If</p>

				<p>BulkListFilled is 1, HC will start processing the Bulk list and will set BF to 0. If HC finds a TD on the list, then HC will set BulkListFilled to 1 causing the Bulk list processing to continue. If no TD is found on the Bulk list, and if HCD does not set BulkListFilled, then BulkListFilled will still be 0 when HC completes processing the Bulk list and Bulk list processing will stop.</p>
1	R/W	R/W	0x0	<p>ControlListFilled This bit is used to indicate whether there are any TDs on the Control list. It is set by HCD whenever it adds a TD to an ED in the Control list. When HC begins to process the head of the Control list, it checks CLF. As long as ControlListFilled is 0, HC will not start processing the Control list. If CF is 1, HC will start processing the Control list and will set ControlListFilled to 0. If HC finds a TD on the list, then HC will set ControlListFilled to 1 causing the Control list processing to continue. If no TD is found on the Control list, and if the HCD does not set ControlListFilled, then ControlListFilled will still be 0 when HC completes processing the Control list and Control list processing will stop.</p>
0	R/W	R/E	0x0	<p>HostControllerReset This bit is by HCD to initiate a software reset of HC. Regardless of the functional state of HC, it moves to the USBsuspend state in which most of the operational registers are reset except those stated otherwise; e.g, the InterruptRouting field of HcControl, and no Host bus accesses are allowed. This bit is cleared by HC upon the completion of the reset operation. The reset operation must be completed within 10 ms. This bit, when set, should not cause a reset to the Root Hub and no subsequent reset signaling should be asserted to its downstream ports.</p>

7.5.3.5.4. HcInterruptStatus Register(Default Value: 0x00000000)

Offset: 0x40c			Register Name: HcInterruptStatus	
Bit	Read/Write		Default/Hex	Description
	HCD	HC		
31:7	/	/	0x0	Reserved
6	R/W	R/W	0x0	<p>RootHubStatusChange This bit is set when the content of HcRhStatus or the content of any of HcRhPortStatus[NumberOfDownstreamPort] has changed.</p>
5	R/W	R/W	0x0	<p>FrameNumberOverflow This bit is set when the MSb of HcFmNumber (bit 15) changes value, from 0 to 1 or from 1 to 0, and after HccaFrameNumber has been updated.</p>

4	R/W	R/W	0x0	<p>UnrecoverableError</p> <p>This bit is set when HC detects a system error not related to USB. HC should not proceed with any processing nor signaling before the system error has been corrected. HCD clears this bit after HC has been reset.</p>
3	R/W	R/W	0x0	<p>ResumeDetected</p> <p>This bit is set when HC detects that a device on the USB is asserting resume signaling. It is the transition from no resume signaling to resume signaling causing this bit to be set. This bit is not set when HCD sets the USBResume state.</p>
2	R/W	R/W	0x0	<p>StartofFrame</p> <p>This bit is set by HC at each start of frame and after the update of HccaFrameNumber. HC also generates a SOF token at the same time.</p>
1	R/W	R/W	0x0	<p>WritebackDoneHead</p> <p>This bit is set immediately after HC has written HcDoneHead to HccaDoneHead. Further updates of the HccaDoneHead will not occur until this bit has been cleared. HCD should only clear this bit after it has saved the content of HccaDoneHead.</p>
0	R/W	R/W	0x0	<p>SchedulingOverrun</p> <p>This bit is set when the USB schedule for the current Frame overruns and after the update of HccaFrameNumber. A scheduling overrun will also cause the SchedulingOverrunCount of HcCommandStatus to be Incremented.</p>

7.5.3.5.5. HcInterruptEnable Register(Default Value: 0x00000000)

Offset: 0x410				Register Name: HcInterruptEnable Register	
Bit	Read/Write		Default/Hex	Description	
	HCD	HC			
31	R/W	R	0x0	<p>MasterInterruptEnable</p> <p>A '0' written to this field is ignored by HC. A '1' written to this field enables interrupt generation due to events specified in the other bits of this register. This is used by HCD as Master Interrupt Enable.</p>	
30:7	/	/	0x0	Reserved	
6	R/W	R	0x0	RootHubStatusChange Interrupt Enable	
				0	Ignore;
				1	Enable interrupt generation due to Root Hub Status Change;
5	R/W	R	0x0	FrameNumberOverflow Interrupt Enable	
				0	Ignore;
				1	Enable interrupt generation due to Frame Number Over Flow;
4	R/W	R	0x0	UnrecoverableError Interrupt Enable	
				0	Ignore;

				1	Enable interrupt generation due to Unrecoverable Error;
3	R/W	R	0x0	ResumeDetected Interrupt Enable	
				0	Ignore;
				1	Enable interrupt generation due to Resume Detected;
2	R/W	R	0x0	StartofFrame Interrupt Enable	
				0	Ignore;
				1	Enable interrupt generation due to Start of Flame;
1	R/W	R	0x0	WritebackDoneHead Interrupt Enable	
				0	Ignore;
				1	Enable interrupt generation due to Write back Done Head;
0	R/W	R	0x0	SchedulingOverrun Interrupt Enable	
				0	Ignore;
				1	Enable interrupt generation due to Scheduling Overrun;

7.5.3.5.6. HcInterruptDisable Register(Default Value: 0x00000000)

Offset: 0x414				Register Name: HcInterruptDisable Register	
Bit	Read/Write		Default/Hex	Description	
	HCD	HC			
31	R/W	R	0x0	MasterInterruptEnable A written '0' to this field is ignored by HC. A '1' written to this field disables interrupt generation due events specified in the other bits of this register. This field is set after a hardware or software reset.	
30:7	/	/	0x00	Reserved	
6	R/W	R	0x0	RootHubStatusChange Interrupt Disable	
				0	Ignore;
				1	Disable interrupt generation due to Root Hub Status Change;
5	R/W	R	0x0	FrameNumberOverflow Interrupt Disable	
				0	Ignore;
				1	Disable interrupt generation due to Frame Number Over Flow;
4	R/W	R	0x0	UnrecoverableError Interrupt Disable	
				0	Ignore;
				1	Disable interrupt generation due to Unrecoverable Error;
3	R/W	R	0x0	ResumeDetected Interrupt Disable	
				0	Ignore;
				1	Disable interrupt generation due to Resume Detected;
2	R/W	R	0x0	StartofFrame Interrupt Disable	
				0	Ignore;
				1	Disable interrupt generation due to Start of Flame;
1	R/W	R	0x0	WritebackDoneHead Interrupt Disable	
				0	Ignore;
				1	Disable interrupt generation due to Write back Done Head;

				1	Disable interrupt generation due to Write back Done Head;
0	R/w	R	0x0	SchedulingOverrun Interrupt Disable	
				0	Ignore;
				1	Disable interrupt generation due to Scheduling Overrun;

7.5.3.5.7. HcHCCA Register(Default Value: 0x00000000)

Offset: 0x418				Register Name: HcHCCA	
Bit	Read/Write		Default/Hex	Description	
	HCD	HC			
31:8	R/W	R	0x0	HCCA[31:8] This is the base address of the Host Controller Communication Area. This area is used to hold the control structures and the Interrupt table that are accessed by both the Host Controller and the Host Controller Driver.	
7:0	R	R	0x0	HCCA[7:0] The alignment restriction in HcHCCA register is evaluated by examining the number of zeros in the lower order bits. The minimum alignment is 256 bytes, therefore, bits 0 through 7 must always return 0 when read.	

7.5.3.5.8. HcPeriodCurrentED Register(Default Value: 0x00000000)

Offset: 0x41c				Register Name: HcPeriodCurrentED(PCED)	
Bit	Read/Write		Default/Hex	Description	
	HCD	HC			
31:4	R	R/W	0x0	PCED[31:4] This is used by HC to point to the head of one of the Periodic list which will be processed in the current Frame. The content of this register is updated by HC after a periodic ED has been processed. HCD may read the content in determining which ED is currently being processed at the time of reading.	
3:0	R	R	0x0	PCED[3:0] Because the general TD length is 16 bytes, the memory structure for the TD must be aligned to a 16-byte boundary. So the lower bits in the PCED, through bit 0 to bit 3 must be zero in this field.	

7.5.3.5.9. HcControlHeadED Register(Default Value: 0x00000000)

Offset: 0x420	Register Name: HcControlHeadED[CHED]
---------------	---

Bit	Read/Write		Default/Hex	Description
	HCD	HC		
31:4	R/W	R	0x0	EHCD[31:4] The HcControlHeadED register contains the physical address of the first Endpoint Descriptor of the Control list. HC traverse the Control list starting with the HcControlHeadED pointer. The content is loaded from HCCA during the initialization of HC.
3:0	R	R	0x0	EHCD[3:0] Because the general TD length is 16 bytes, the memory structure for the TD must be aligned to a 16-byte boundary. So the lower bits in the PCED, through bit 0 to bit 3 must be zero in this field.

7.5.3.5.10. HcControlCurrentED Register(Default Value: 0x00000000)

Offset: 0x424				Register Name: HcControlCurrentED[CCED]
Bit	Read/Write		Default/Hex	Description
	HCD	HC		
31:4	R/W	R/W	0x0	CCED[31:4] The pointer is advanced to the next ED after serving the present one. HC will continue processing the list from where it left off in the last Frame. When it reaches the end of the Control list, HC checks the ControlListFilled of in HcCommandStatus. If set, it copies the content of HcControlHeadED to HcControlCurrentED and clears the bit. If not set, it does nothing. HCD is allowed to modify this register only when the ControlListEnable of HcControl is cleared. When set, HCD only reads the instantaneous value of this register. Initially, this is set to zero to indicate the end of the Control list.
3:0	R	R	0x0	CCED[3:0] Because the general TD length is 16 bytes, the memory structure for the TD must be aligned to a 16-byte boundary. So the lower bits in the PCED, through bit 0 to bit 3 must be zero in this field.

7.5.3.5.11. HcBulkHeadED Register(Default Value: 0x00000000)

Offset: 0x428				Register Name: HcBulkHeadED[BHED]
Bit	Read/Write		Default/Hex	Description
	HCD	HC		
31:4	R/W	R	0x0	BHED[31:4] The HcBulkHeadED register contains the physical address of the first

				Endpoint Descriptor of the Bulk list. HC traverses the Bulk list starting with the HcBulkHeadED pointer. The content is loaded from HCCA during the initialization of HC.
3:0	R	R	0x0	BHED[3:0] Because the general TD length is 16 bytes, the memory structure for the TD must be aligned to a 16-byte boundary. So the lower bits in the PCED, through bit 0 to bit 3 must be zero in this field.

7.5.3.5.12. HcBulkCurrentED Register(Default Value: 0x00000000)

Offset: 0x42c			Register Name: HcBulkCurrentED [BCED]	
Bit	Read/Write		Default/Hex	Description
	HCD	HC		
31:4	R/W	R/W	0x0	BulkCurrentED[31:4] This is advanced to the next ED after the HC has served the present one. HC continues processing the list from where it left off in the last Frame. When it reaches the end of the Bulk list, HC checks the ControlListFilled of HcControl. If set, it copies the content of HcBulkHeadED to HcBulkCurrentED and clears the bit. If it is not set, it does nothing. HCD is only allowed to modify this register when the BulkListEnable of HcControl is cleared. When set, the HCD only reads the instantaneous value of this register. This is initially set to zero to indicate the end of the Bulk list.
3:0	R	R	0x0	BulkCurrentED [3:0] Because the general TD length is 16 bytes, the memory structure for the TD must be aligned to a 16-byte boundary. So the lower bits in the PCED, through bit 0 to bit 3 must be zero in this field.

7.5.3.5.13. HcDoneHead Register(Default Value: 0x00000000)

Offset: 0x430			Register Name: HcDoneHead	
Bit	Read/Write		Default/Hex	Description
	HCD	HC		
31:4	R	R/W	0x0	HcDoneHead[31:4] When a TD is completed, HC writes the content of HcDoneHead to the NextTD field of the TD. HC then overwrites the content of HcDoneHead with the address of this TD. This is set to zero whenever HC writes the content of this register to HCCA. It also sets the WritebackDoneHead of HcInterruptStatus.
3:0	R	R	0x0	HcDoneHead[3:0] Because the general TD length is 16 bytes, the memory structure for

				the TD must be aligned to a 16-byte boundary. So the lower bits in the PCED, through bit 0 to bit 3 must be zero in this field.
--	--	--	--	---

7.5.3.5.14. HcFmInterval Register(Default Value: 0x00002EDF)

Offset: 0x434				Register Name: HcFmInterval Register
Bit	Read/Write		Default/Hex	Description
	HCD	HC		
31	R/W	R	0x0	FrameIntervalToggler HCD toggles this bit whenever it loads a new value to FrameInterval.
30:16	R/W	R	0x0	FSLargestDataPacket This field specifies a value which is loaded into the Largest Data Packet Counter at the beginning of each frame. The counter value represents the largest amount of data in bits which can be sent or received by the HC in a single transaction at any given time without causing scheduling overrun. The field value is calculated by the HCD.
15:14	/	/	0x0	Reserved
13:0	R/W	R	0x2edf	FrameInterval This specifies the interval between two consecutive SOFs in bit times. The nominal value is set to be 11,999. HCD should store the current value of this field before resetting HC. By setting the HostControllerReset field of HcCommandStatus as this will cause the HC to reset this field to its nominal value. HCD may choose to restore the stored value upon the completion of the Reset sequence.

7.5.3.5.15. HcFmRemaining Register(Default Value: 0x00000000)

Offset: 0x438				Register Name: HcFmRemaining
Bit	Read/Write		Default/Hex	Description
	HCD	HC		
31	R	R/W	0x0	FrameRemaining Toggle This bit is loaded from the FrameIntervalToggle field of HcFmInterval whenever FrameRemaining reaches 0. This bit is used by HCD for the synchronization between FrameInterval and FrameRemaining.
30:14	/	/	0x0	Reserved
13:0	R	RW	0x0	FramRemaining This counter is decremented at each bit time. When it reaches zero, it is reset by loading the FrameInterval value specified in HcFmInterval at the next bit time boundary. When entering the USBOPERATIONAL state, HC re-loads the content with the FrameInterval of HcFmInterval and uses the updated value from the next SOF.

7.5.3.5.16. HcFmNumber Register(Default Value: 0x00000000)

Offset: 0x43c				Register Name: HcFmNumber
Bit	Read/Write		Default/Hex	Description
	HCD	HC		
31:16	/	/	/	Reserved
15:0	R	R/W	0x0	<p>FrameNumber</p> <p>This is incremented when HcFmRemaining is re-loaded. It will be rolled over to 0x0 after 0x0fff. When entering the USBOPERATIONAL state, this will be incremented automatically. The content will be written to HCCA after HC has incremented the FrameNumber at each frame boundary and sent a SOF but before HC reads the first ED in that Frame. After writing to HCCA, HC will set the StartofFrame in HcInterruptStatus.</p>

7.5.3.5.17. HcPeriodicStart Register(Default Value: 0x00000000)

Offset: 0x440				Register Name: HcPeriodicStatus
Bit	Read/Write		Default/Hex	Description
	HCD	HC		
31:14	/	/	/	Reserved
13:0	R/W	R	0x0	<p>PeriodicStart</p> <p>After a hardware reset, this field is cleared. This is then set by HCD during the HC initialization. The value is calculated roughly as 10% off from HcFmInterval. A typical value will be 0x2A3F (0x3e67). When HcFmRemaining reaches the value specified, processing of the periodic lists will have priority over Control/Bulk processing. HC will therefore start processing the Interrupt list after completing the current Control or Bulk transaction that is in progress.</p>

7.5.3.5.18. HcLSThreshold Register(Default Value: 0x00000628)

Offset: 0x444				Register Name: HcLSThreshold
Bit	Read/Write		Default/Hex	Description
	HCD	HC		
31:12				Reserved
11:0	R/W	R	0x0628	<p>LSThreshold</p> <p>This field contains a value which is compared to the FrameRemaining</p>

				field prior to initiating a Low Speed transaction. The transaction is started only if FrameRemaining ³ this field. The value is calculated by HCD with the consideration of transmission and setup overhead.
--	--	--	--	---

7.5.3.5.19. HcRhDescriptorA Register(Default Value: 0x02001201)

Offset: 0x448				Register Name: HcRhDescriptorA				
Bit	Read/Write		Default/Hex	Description				
	HCD	HC						
31:24	R/W	R	0x2	<p>PowerOnToPowerGoodTime[POTPGT] This byte specifies the duration HCD has to wait before accessing a powered-on port of the Root Hub. It is implementation-specific. The unit of time is 2 ms. The duration is calculated as POTPGT * 2ms.</p>				
23:13				Reserved				
12	R/W	R	1	<p>NoOverCurrentProtection This bit describes how the overcurrent status for the Root Hub ports are reported. When this bit is cleared, the OverCurrentProtectionMode field specifies global or per-port reporting.</p> <table border="1"> <tr> <td>0</td> <td>Over-current status is reported collectively for all downstream ports.</td> </tr> <tr> <td>1</td> <td>No overcurrent protection supported.</td> </tr> </table>	0	Over-current status is reported collectively for all downstream ports.	1	No overcurrent protection supported.
0	Over-current status is reported collectively for all downstream ports.							
1	No overcurrent protection supported.							
11	R/W	R	0	<p>OverCurrentProtectionMode This bit describes how the overcurrent status for the Root Hub ports are reported. At reset, these fields should reflect the same mode as PowerSwitchingMode. This field is valid only if the NoOverCurrentProtection field is cleared.</p> <table border="1"> <tr> <td>0</td> <td>Over-current status is reported collectively for all downstream ports.</td> </tr> <tr> <td>1</td> <td>Over-current status is reported on per-port basis.</td> </tr> </table>	0	Over-current status is reported collectively for all downstream ports.	1	Over-current status is reported on per-port basis.
0	Over-current status is reported collectively for all downstream ports.							
1	Over-current status is reported on per-port basis.							
10	R	R	0x0	<p>Device Type This bit specifies that the Root Hub is not a compound device. The Root Hub is not permitted to be a compound device. This field should always read/write 0.</p>				
9	R/W	R	1	<p>PowerSwitchingMode This bit is used to specify how the power switching of the Root Hub ports is controlled. It is implementation-specific. This field is only valid if the NoPowerSwitching field is cleared.</p> <table border="1"> <tr> <td>0</td> <td>All ports are powered at the same time.</td> </tr> <tr> <td>1</td> <td>Each port is powered individually. This mode allows port power to be controlled by either the global switch or per-port switching. If the PortPowerControlMask bit is set, the port</td> </tr> </table>	0	All ports are powered at the same time.	1	Each port is powered individually. This mode allows port power to be controlled by either the global switch or per-port switching. If the PortPowerControlMask bit is set, the port
0	All ports are powered at the same time.							
1	Each port is powered individually. This mode allows port power to be controlled by either the global switch or per-port switching. If the PortPowerControlMask bit is set, the port							

				responds only to port power commands (Set/ClearPortPower). If the port mask is cleared, then the port is controlled only by the global power switch (Set/ClearGlobalPower).				
8	R/W	R	0	<p>NoPowerSwitching</p> <p>These bits are used to specify whether power switching is supported or ports are always powered. It is implementation-specific. When this bit is cleared, the PowerSwitchingMode specifies global or per-port switching.</p> <table border="1"> <tr> <td>0</td> <td>Ports are power switched.</td> </tr> <tr> <td>1</td> <td>Ports are always powered on when the HC is powered on.</td> </tr> </table>	0	Ports are power switched.	1	Ports are always powered on when the HC is powered on.
0	Ports are power switched.							
1	Ports are always powered on when the HC is powered on.							
7:0	R	R	0x01	<p>NumberDownstreamPorts</p> <p>These bits specify the number of downstream ports supported by the Root Hub. It is implementation-specific. The minimum number of ports is 1. The maximum number of ports supported.</p>				

7.5.3.5.20. HcRhDescriptorB Register(Default Value: 0x00000000)

Offset: 0x44c				Register Name: HcRhDescriptorB Register										
Bit	Read/Write		Default/Hex	Description										
	HCD	HC												
31:16	R/W	R	0x0	<p>PortPowerControlMask</p> <p>Each bit indicates if a port is affected by a global power control command when PowerSwitchingMode is set. When set, the port's power state is only affected by per-port power control (Set/ClearPortPower). When cleared, the port is controlled by the global power switch (Set/ClearGlobalPower). If the device is configured to global switching mode (PowerSwitchingMode = 0), this field is not valid.</p> <table border="1"> <tr> <td>Bit0</td> <td>Reserved</td> </tr> <tr> <td>Bit1</td> <td>Ganged-power mask on Port #1.</td> </tr> <tr> <td>Bit2</td> <td>Ganged-power mask on Port #2.</td> </tr> <tr> <td>...</td> <td></td> </tr> <tr> <td>Bit15</td> <td>Ganged-power mask on Port #15.</td> </tr> </table>	Bit0	Reserved	Bit1	Ganged-power mask on Port #1.	Bit2	Ganged-power mask on Port #2.	...		Bit15	Ganged-power mask on Port #15.
Bit0	Reserved													
Bit1	Ganged-power mask on Port #1.													
Bit2	Ganged-power mask on Port #2.													
...														
Bit15	Ganged-power mask on Port #15.													
15:0	R/W	R	0x0	<p>DeviceRemovable</p> <p>Each bit is dedicated to a port of the Root Hub. When cleared, the attached device is removable. When set, the attached device is not removable.</p> <table border="1"> <tr> <td>Bit0</td> <td>Reserved</td> </tr> <tr> <td>Bit1</td> <td>Device attached to Port #1.</td> </tr> <tr> <td>Bit2</td> <td>Device attached to Port #2.</td> </tr> <tr> <td>...</td> <td></td> </tr> </table>	Bit0	Reserved	Bit1	Device attached to Port #1.	Bit2	Device attached to Port #2.	...			
Bit0	Reserved													
Bit1	Device attached to Port #1.													
Bit2	Device attached to Port #2.													
...														

				Bit15	Device attached to Port #15.
--	--	--	--	-------	------------------------------

7.5.3.5.21. HcRhStatus Register(Default Value: 0x00000000)

Offset: 0x450				Register Name: HcRhStatus Register				
Bit	Read/Write		Default/Hex	Description				
	HCD	HC						
31	W	R	0	(write)ClearRemoteWakeupEnable Write a '1' clears DeviceRemoteWakeupEnable. Write a '0' has no effect.				
30:18	/	/	0x0	Reserved				
17	R/W	R	0	OverCurrentIndicatorChang This bit is set by hardware when a change has occurred to the OverCurrentIndicator field of this register. The HCD clears this bit by writing a '1'.Writing a '0' has no effect.				
16	R/W	R	0x0	(read)LocalPowerStartusChange The Root Hub does not support the local power status features, thus, this bit is always read as '0'. (write)SetGlobalPower In global power mode (PowerSwitchingMode=0), This bit is written to '1' to turn on power to all ports (clear PortPowerStatus). In per-port power mode, it sets PortPowerStatus only on ports whose PortPowerControlMask bit is not set. Writing a '0' has no effect.				
15	R/W	R	0x0	(read)DeviceRemoteWakeupEnable This bit enables a ConnectStatusChange bit as a resume event, causing a USBsuspend to USBRESUME state transition and setting the ResumeDetected interrupt. <table border="1" data-bbox="635 1420 1442 1509"> <tr> <td>0</td> <td>ConnectStatusChange is not a remote wakeup event.</td> </tr> <tr> <td>1</td> <td>ConnectStatusChange is a remote wakeup event.</td> </tr> </table> (write)SetRemoteWakeupEnable Writing a '1' sets DeviceRemoveWakeupEnable. Writing a '0' has no effect.	0	ConnectStatusChange is not a remote wakeup event.	1	ConnectStatusChange is a remote wakeup event.
0	ConnectStatusChange is not a remote wakeup event.							
1	ConnectStatusChange is a remote wakeup event.							
14:2				Reserved				
1	R	R/W	0x0	OverCurrentIndicator This bit reports overcurrent conditions when the global reporting is implemented. When set, an overcurrent condition exists. When cleared, all power operations are normal. If per-port overcurrent protection is implemented this bit is always '0'				
0	R/W	R	0x0	(Read)LocalPowerStatus When read, this bit returns the LocalPowerStatus of the Root Hub. The				

				<p>Root Hub does not support the local power status feature; thus, this bit is always read as '0'.</p> <p>(Write)ClearGlobalPower</p> <p>When write, this bit is operated as the ClearGlobalPower. In global power mode (PowerSwitchingMode=0), This bit is written to '1' to turn off power to all ports (clear PortPowerStatus). In per-port power mode, it clears PortPowerStatus only on ports whose PortPowerControlMask bit is not set. Writing a '0' has no effect.</p>
--	--	--	--	--

7.5.3.5.22. HcRhPortStatus Register(Default Value: 0x0000100)

Offset: 0x454				Register Name: HcRhPortStatus
Bit	Read/Write		Default/Hex	Description
	HCD	HC		
31:21	/	/	0x0	Reserved
20	R/W	R/W	0x0	<p>PortResetStatusChange</p> <p>This bit is set at the end of the 10-ms port reset signal. The HCD writes a '1' to clear this bit. Writing a '0' has no effect.</p>
				<table border="1"> <tr> <td>0</td> <td>port reset is not complete</td> </tr> <tr> <td>1</td> <td>port reset is complete</td> </tr> </table>
0	port reset is not complete			
1	port reset is complete			
19	R/W	R/W	0x0	<p>PortOverCurrentIndicatorChange</p> <p>This bit is valid only if overcurrent conditions are reported on a per-port basis. This bit is set when Root Hub changes the PortOverCurrentIndicator bit. The HCD writes a '1' to clear this bit. Writing a '0' has no effect.</p>
				<table border="1"> <tr> <td>0</td> <td>no change in PortOverCurrentIndicator</td> </tr> <tr> <td>1</td> <td>PortOverCurrentIndicator has changed</td> </tr> </table>
0	no change in PortOverCurrentIndicator			
1	PortOverCurrentIndicator has changed			
18	R/W	R/W	0x0	<p>PortSuspendStatusChange</p> <p>This bit is set when the full resume sequence has been completed. This sequence includes the 20-s resume pulse, LS EOP, and 3-ms resynchronization delay. The HCD writes a '1' to clear this bit. Writing a '0' has no effect. This bit is also cleared when ResetStatusChange is set.</p>
				<table border="1"> <tr> <td>0</td> <td>resume is not completed</td> </tr> <tr> <td>1</td> <td>resume completed</td> </tr> </table>
0	resume is not completed			
1	resume completed			
17	R/W	R/W	0x0	<p>PortEnableStatusChange</p> <p>This bit is set when hardware events cause the PortEnableStatus bit to be cleared. Changes from HCD writes do not set this bit. The HCD writes a '1' to clear this bit. Writing a '0' has no effect.</p>
				<table border="1"> <tr> <td>0</td> <td>no change in PortEnableStatus</td> </tr> <tr> <td>1</td> <td>change in PortEnableStatus</td> </tr> </table>
0	no change in PortEnableStatus			
1	change in PortEnableStatus			
16	R/W	R/W	0x0	ConnectStatusChange

				<p>This bit is set whenever a connect or disconnect event occurs. The HCD writes a '1' to clear this bit. Writing a '0' has no effect. If CurrentConnectStatus is cleared when a SetPortReset, SetPortEnable, or SetPortSuspend write occurs, this bit is set to force the driver to re-evaluate the connection status since these writes should not occur if the port is disconnected.</p> <table border="1"> <tr> <td>0</td> <td>no change in PortEnableStatus</td> </tr> <tr> <td>1</td> <td>change in PortEnableStatus</td> </tr> </table> <p>Note: If the DeviceRemovable[NDP] bit is set, this bit is set only after a Root Hub reset to inform the system that the device is attached.</p>	0	no change in PortEnableStatus	1	change in PortEnableStatus
0	no change in PortEnableStatus							
1	change in PortEnableStatus							
15:10	/	/	0x0	Reserved				
				<p>(read)LowSpeedDeviceAttached</p> <p>This bit indicates the speed of the device attached to this port. When set, a Low Speed device is attached to this port. When clear, a Full Speed device is attached to this port. This field is valid only when the CurrentConnectStatus is set.</p> <table border="1"> <tr> <td>0</td> <td>full speed device attached</td> </tr> <tr> <td>1</td> <td>low speed device attached</td> </tr> </table> <p>(write)ClearPortPower</p> <p>The HCD clears the PortPowerStatus bit by writing a '1' to this bit. Writing a '0' has no effect.</p>	0	full speed device attached	1	low speed device attached
0	full speed device attached							
1	low speed device attached							
9	R/W	R/W	-					
				<p>(read)PortPowerStatus</p> <p>This bit reflects the port's power status, regardless of the type of power switching implemented. This bit is cleared if an overcurrent condition is detected. HCD sets this bit by writing SetPortPower or SetGlobalPower. HCD clears this bit by writing ClearPortPower or ClearGlobalPower. Which power control switches are enabled is determined by PowerSwitchingMode and PortPortControlMask[NumberDownstreamPort]. In global switching mode(PowerSwitchingMode=0), only Set/ClearGlobalPower controls this bit. In per-port power switching (PowerSwitchingMode=1), if the PortPowerControlMask[NDP] bit for the port is set, only Set/ClearPortPower commands are enabled. If the mask is not set, only Set/ClearGlobalPower commands are enabled. When port power is disabled, CurrentConnectStatus, PortEnableStatus, PortSuspendStatus, and PortResetStatus should be reset.</p> <table border="1"> <tr> <td>0</td> <td>port power is off</td> </tr> <tr> <td>1</td> <td>port power is on</td> </tr> </table> <p>(write)SetPortPower</p>	0	port power is off	1	port power is on
0	port power is off							
1	port power is on							
8	R/W	R/W	0x1					

				<p>The HCD writes a '1' to set the PortPowerStatus bit. Writing a '0' has no effect.</p> <p>Note: This bit is always reads '1b' if power switching is not supported.</p>				
7:5	/	/	0x0	Reserved				
4	R/W	R/W	0x0	<p>(read)PortResetStatus</p> <p>When this bit is set by a write to SetPortReset, port reset signaling is asserted. When reset is completed, this bit is cleared when PortResetStatusChange is set. This bit cannot be set if CurrentConnectStatus is cleared.</p> <table border="1"> <tr> <td>0</td> <td>port reset signal is not active</td> </tr> <tr> <td>1</td> <td>port reset signal is active</td> </tr> </table> <p>(write)SetPortReset</p> <p>The HCD sets the port reset signaling by writing a '1' to this bit. Writing a '0' has no effect. If CurrentConnectStatus is cleared, this write does not set PortResetStatus, but instead sets ConnectStatusChange. This informs the driver that it attempted to reset a disconnected port.</p>	0	port reset signal is not active	1	port reset signal is active
0	port reset signal is not active							
1	port reset signal is active							
3	R/W	R/W	0x0	<p>(read)PortOverCurrentIndicator</p> <p>This bit is only valid when the Root Hub is configured in such a way that overcurrent conditions are reported on a per-port basis. If per-port overcurrent reporting is not supported, this bit is set to 0. If cleared, all power operations are normal for this port. If set, an overcurrent condition exists on this port. This bit always reflects the overcurrent input signal.</p> <table border="1"> <tr> <td>0</td> <td>no overcurrent condition.</td> </tr> <tr> <td>1</td> <td>overcurrent condition detected.</td> </tr> </table> <p>(write)ClearSuspendStatus</p> <p>The HCD writes a '1' to initiate a resume. Writing a '0' has no effect. A resume is initiated only if PortSuspendStatus is set.</p>	0	no overcurrent condition.	1	overcurrent condition detected.
0	no overcurrent condition.							
1	overcurrent condition detected.							
2	R/W	R/W	0x0	<p>(read)PortSuspendStatus</p> <p>This bit indicates the port is suspended or in the resume sequence. It is set by a SetSuspendState write and cleared when PortSuspendStatusChange is set at the end of the resume interval. This bit cannot be set if CurrentConnectStatus is cleared. This bit is also cleared when PortResetStatusChange is set at the end of the port reset or when the HC is placed in the USBRESUME state. If an upstream resume is in progress, it should propagate to the HC.</p> <table border="1"> <tr> <td>0</td> <td>port is not suspended</td> </tr> <tr> <td>1</td> <td>port is suspended</td> </tr> </table> <p>(write)SetPortSuspend</p>	0	port is not suspended	1	port is suspended
0	port is not suspended							
1	port is suspended							

				<p>The HCD sets the PortSuspendStatus bit by writing a '1' to this bit. Writing a '0' has no effect. If CurrentConnectStatus is cleared, this write does not set PortSuspendStatus; instead it sets ConnectStatusChange. This informs the driver that it attempted to suspend a disconnected port.</p>				
1	R/W	R/W	0x0	<p>(read)PortEnableStatus This bit indicates whether the port is enabled or disabled. The Root Hub may clear this bit when an overcurrent condition, disconnect event, switched-off power, or operational bus error such as babble is detected. This change also causes PortEnabledStatusChange to be set. HCD sets this bit by writing SetPortEnable and clears it by writing ClearPortEnable. This bit cannot be set when CurrentConnectStatus is cleared. This bit is also set, if not already, at the completion of a port reset when ResetStatusChange is set or port suspend when SuspendStatusChange is set.</p> <table border="1"> <tr> <td>0</td> <td>port is disabled</td> </tr> <tr> <td>1</td> <td>port is enabled</td> </tr> </table> <p>(write)SetPortEnable The HCD sets PortEnableStatus by writing a '1'. Writing a '0' has no effect. If CurrentConnectStatus is cleared, this write does not set PortEnableStatus, but instead sets ConnectStatusChange. This informs the driver that it attempted to enable a disconnected Port.</p>	0	port is disabled	1	port is enabled
0	port is disabled							
1	port is enabled							
0	R/W	R/W	0x0	<p>(read)CurrentConnectStatus This bit reflects the current state of the downstream port.</p> <table border="1"> <tr> <td>0</td> <td>No device connected</td> </tr> <tr> <td>1</td> <td>Device connected</td> </tr> </table> <p>(write)ClearPortEnable The HCD writes a '1' to clear the PortEnableStatus bit. Writing '0' has no effect. The CurrentConnectStatus is not affected by any write. Note: This bit is always read '1' when the attached device is nonremovable(DviceRemoveable[NumberDownstreamPort]).</p>	0	No device connected	1	Device connected
0	No device connected							
1	Device connected							

7.5.3.6. HCI Interface Control and Status Register Description

7.5.3.6.1. HCI Interface Control Register(Default Value: 0x00000000)

Offset: 0x800			Register Name: HCI_ICR
Bit	R/W	Default/Hex	Description
31:21	/	/	Reserved.
20	R/W	0	EHCI HS force Set 1 to this field force the ehci enter the high speed mode during bus

			reset. This field only valid when the bit 1 is set.
19:18	/	/	/
17	R/W	0	HSIC Connect detect 1 in this field enable the hsic phy to detect device connect pulse on the bus. This field only valid when the bit 1 is set.
16	R/W	0	HSIC Connect Interrupt Enable Enable the HSIC connect interrupt. This field only valid when the bit 1 is set.
15:13	/	/	/
12	/	/	/
11	R/W	0	AHB Master interface INCR16 enable 1: Use INCR16 when appropriate 0: do not use INCR16,use other enabled INCRX or unspecified length burst INCR
10	R/W	0	AHB Master interface INCR8 enable 1: Use INCR8 when appropriate 0: do not use INCR8,use other enabled INCRX or unspecified length burst INCR
9	R/W	0	AHB Master interface burst type INCR4 enable 1: Use INCR4 when appropriate 0: do not use INCR4,use other enabled INCRX or unspecified length burst INCR
8	R/W	0	AHB Master interface INCRX align enable 1: start INCRx burst only on burst x-align address 0: Start burst on any double word boundary Note: This bit must enable if any bit of 11:9 is enabled
7:2	/	/	Reserved
1	R/W	0	HSIC 0:/ 1:HSIC This meaning is only valid when the controller is HCI1.
0	R/W	0	ULPI bypass enable。 1: Enable UTMI interface, disable ULPI interface(SP used utmi interface) 0: Enable ULPI interface, disable UTMI interface

7.5.3.6.2. HSIC status Register(Default Value: 0x00000000)

Offset: 0x804			Register Name: HSIC_STATUS
Bit	R/W	Default/Hex	Description

31:17	/	/	/
			<p>HSIC Connect Status</p> <p>1 in this field indicates a device connect pulse being detected on the bus. This field only valid when the EHCI HS force bit and the HSIC Phy Select bit is set.</p> <p>When the HSIC Connect Interrupt Enable is set, 1 in this bit will generate an interrupt to the system.</p>
16	R/W	0	This register is valid on HCl1.
15:0	/	/	/

7.5.3.7. USB Host Clock Requirement

Name	Description
HCLK	System clock (provided by AHB bus clock). This clock needs to be >30MHz.
CLK60M	Clock from PHY for HS SIE, is constant to be 60MHz.
CLK48M	Clock from PLL for FS/LS SIE, is constant to be 48MHz.

7.6. I2S/PCM

7.6.1. Overview

The I2S/PCM Controller has been designed to transfer streaming audio-data between the system memory and the codec chip. The controller supports standard I2S format, Left-justified Mode format, Right-justified Mode format, PCM Mode format and TDM Mode format.

The I2S/PCM controller includes the following features:

- Compliant with standard Philips Inter-IC sound (I2S) bus specification
- Compliant with Left-justified, Right-justified, PCM mode, and TDM (Time Division Multiplexing) format
- Support different sample period width in each interface when using LRCK and LRCKR at the same time
- Support full-duplex synchronous work mode
- Support Master / Slave mode
- Support adjustable interface voltage
- Support clock up to 100MHz
- Support adjustable audio sample rate from 8-bit to 32-bit.
- Support up to 8 slots which has adjustable width from 8-bit to 32-bit.
- Support sample rate from 8KHz to 192KHz
- Support 8-bits u-law and 8-bits A-law companded sample
- One 128 x 32-bit width FIFO for data transmit, one 64 x 32-bit width FIFO for data receive
- Support programmable PCM frame width: 1 BCLK width (short frame) and 2 BCLKs width (long frame)
- Programmable FIFO thresholds
- Interrupt and DMA Support
- Support loopback mode for test
- Support Audio HUB

7.6.2. Signal Description

7.6.2.1. I2S/PCM Pin List

Signal Name(x=0,1)	Direction(M)	Description
PCMx_BCLK	I/O	I2S/PCM x BCLK Output
PCMx_SYNC	I/O	I2S/PCM x Sample Rate Clock/Sync
PCMx_DIN	I	I2S/PCM x Serial Data Input
PCMx_DOUT	O	I2S/PCM x Serial Data Output
I2S_MCLK	O	I2S CLK Output

7.6.2.2. Digital Audio Interface Clock Source and Frequency

	Description
Audio_PLL	24.576Mhz or 22.5792Mhz generated by AUDIO-PLL to produce 48KHz or 44.1KHz serial frequency

7.6.3. Functionalities Description

7.6.3.1. Typical Applications

The I2S/PCM provides a serial bus interface for stereo and multichannel audio data. This interface is most commonly used by consumer audio market, including compact disc, digital audio tape, digital sound processors, and digital TV-sound.

7.6.3.2. Functional Block Diagram

The I2S/PCM Interface block diagram is shown below:

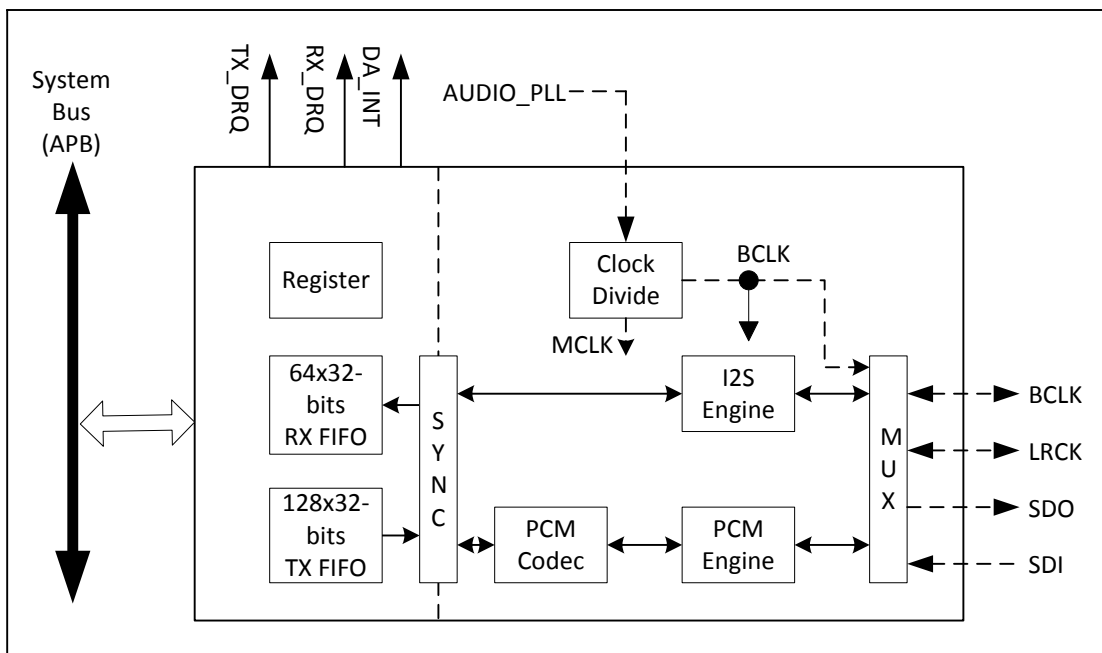

Figure 7-8. I2S/PCM Interface System Block Diagram

7.6.4. Timing Diagram

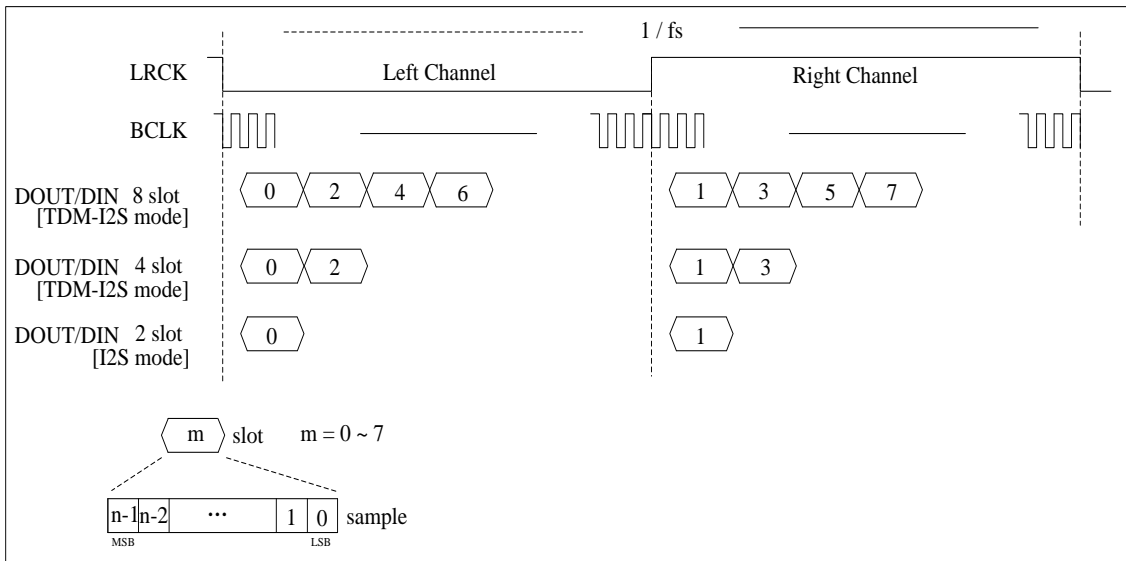

Figure 7-9. Timing Diagram for I2S/TDM-I2S mode

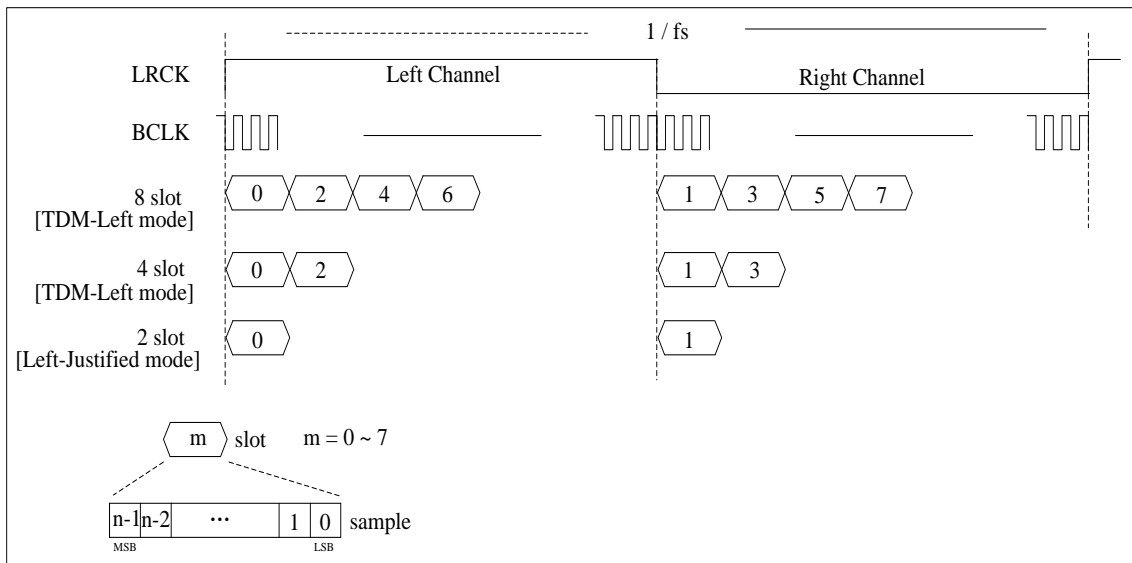

Figure 7-10. Timing Diagram for Left-justified/TDM-Left mode

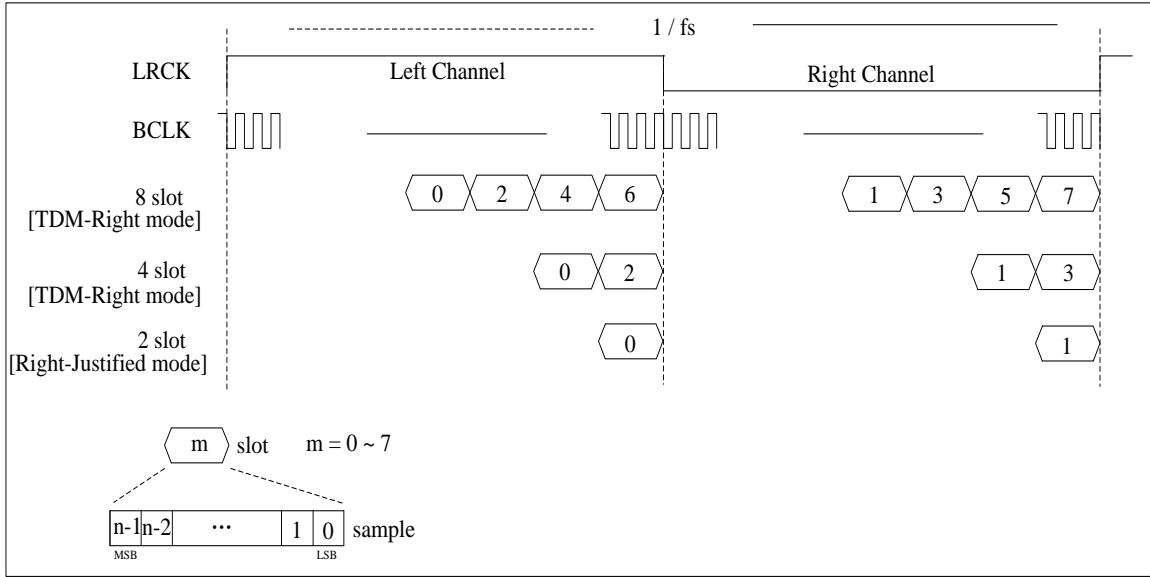

Figure 7-11. Timing Diagram for Right-justified/TDM-Right mode

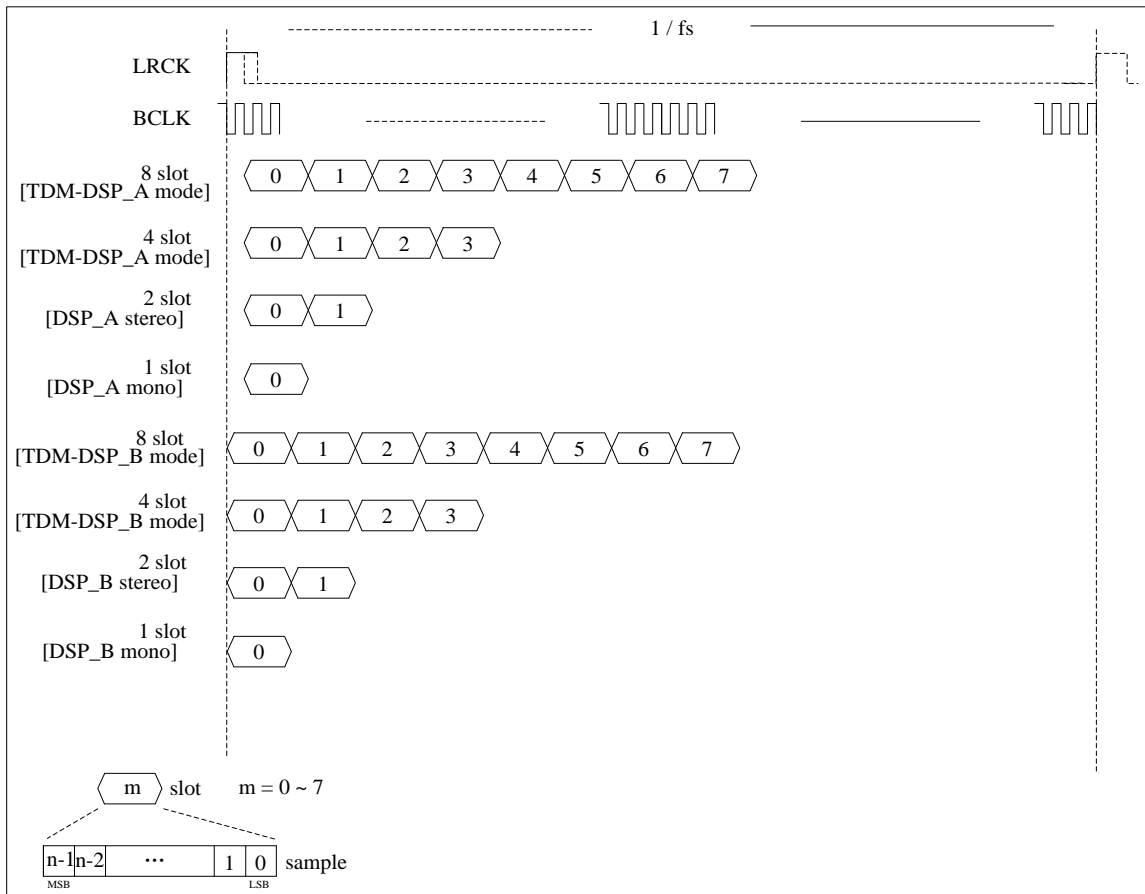

Figure 7-12. Timing Diagram for PCM/TDM-PCM mode

7.6.5. Operation Modes

The software operation of the I2S/PCM is divided into five steps: system setup, PCM/I2S initialization, the channel setup, DMA setup and Enable/Disable module. These five steps are described in detail in the following sections.

7.6.5.1. System setup and I2S/PCM initialization

The first step in the system setup is properly programming the GPIO. Because the I2S/PCM port is a multiplex pin. You can find the function in the pin multiplex specification. The clock source for the I2S/PCM should be followed. At first you must reset the audio PLL through the **PLL_ENABLE** bit of **PLL_AUDIO_CTRL_REG** in the **CCU**. The second step, you must setup the frequency of the audio pll in the **PLL_AUDIO_CTRL_REG**. After that, you must open the I2S/PCM gating through the **I2S/PCM 0_CLK_REG** / **I2S/PCM 1_CLK_REG** when you checkout that the LOCK bit of **PLL_AUDIO_CTRL_REG** become 1. At last, you must reset the I2S/PCM in **BUS_SOFT_RST_REG3**'s bit[13:12] and open the I2S/PCM bus gating in the **BUS_CLK_GATING_REG2**'s bit[13:12].

After the system setup, the register of I2S/PCM can be setup. At first, you should initialization the I2S/PCM. You should closed the **Globe Enable** bit(**I2S/PCM_CTL[0]**) , **Transmitter Block Enable** bit(**I2S/PCM_CTL[2]**) and **Receiver Block Enable** bit(**I2S/PCM_CTL[1]**) by write 0 to it. After that, you must clear the TX/RX FIFO by write 0 to register **I2S/PCM_FCTL[25:24]**. At last, you can clear the TX/RX FIFO counter by write 0 to **I2S/PCM_TXCNT/I2S/PCM_RXCNT**.

7.6.5.2. The channel setup and DMA setup

Before the usage and control of I2S/PCM, you must configure the I2C. The configuration of I2C will not describe in this chapter. But you can only configure I2S/PCM of master and slave through the I2C. In the following, you can setup the I2S/PCM of mater and slave. The configuration can be referred to the the protocol of I2S/PCM. Then, you can set the translation mode, the sample precision, the wide of slot, the frame mode and the trigger level. The register set can be found in the spec.

The I2S/PCM supports three methods to transfer the data. The most common way is DMA, the set of DMA can be found in the **DMA**. In this module, you just to enable the DRQ.

7.6.5.3. Enable and disable the I2S/PCM

To enable the function, you can enable TX/RX by write the **I2S/PCM_CTL[2:1]**. After that, you must enable I2S/PCM by write the Globe Enable bit to 1 in the **I2S/PCM_CTL**. The disable process is writed the **Globe Enable** to 0.

7.6.6. I2S/PCM Register List

Module Name	Base Address
I2S/PCM 0	0x01C22000
I2S/PCM 1	0x01C22400
I2S/PCM 2	0x01C22800 (for HDMI)

Register Name	Offset	Description
I2S/PCM_CTL	0x00	I2S/PCM Control Register
I2S/PCM_FMT0	0x04	I2S/PCM Format Register 0
I2S/PCM_FMT1	0x08	I2S/PCM Format Register 1
I2S/PCM_ISTA	0x0C	I2S/PCM Interrupt Status Register
I2S/PCM_RXFIFO	0x10	I2S/PCM RX FIFO Register
I2S/PCM_FCTL	0x14	I2S/PCM FIFO Control Register
I2S/PCM_FSTA	0x18	I2S/PCM FIFO Status Register
I2S/PCM_INT	0x1C	I2S/PCM DMA & Interrupt Control Register
I2S/PCM_TXFIFO	0x20	I2S/PCM TX FIFO Register
I2S/PCM_CLKD	0x24	I2S/PCM Clock Divide Register
I2S/PCM_TXCNT	0x28	I2S/PCM TX Sample Counter Register
I2S/PCM_RXCNT	0x2C	I2S/PCM RX Sample Counter Register
I2S/PCM_CHCFG	0x30	I2S/PCM Channel Configuration register
I2S/PCM_TX0CHCFG	0x34	I2S/PCM TX0 Channel Configuration register
I2S/PCM_TX1CHSEL	0x38	I2S/PCM TX1 Channel Select Register
I2S/PCM_TX2CHSEL	0x3C	I2S/PCM TX2 Channel Select Register
I2S/PCM_TX3CHSEL	0x40	I2S/PCM TX3 Channel Select Register
I2S/PCM_TX0CHMAP	0x44	I2S/PCM TX0 Channel Mapping Register
I2S/PCM_TX1CHMAP	0x48	I2S/PCM TX1 Channel Mapping Register
I2S/PCM_TX2CHMAP	0x4C	I2S/PCM TX2 Channel Mapping Register
I2S/PCM_TX3CHMAP	0x50	I2S/PCM TX3 Channel Mapping Register
I2S/PCM_RXCHSEL	0x54	I2S/PCM RX Channel Select register
I2S/PCM_RXCHMAP	0x58	I2S/PCM RX Channel Mapping Register

7.6.7. I2S/PCM Register Description

7.6.7.1. I2S/PCM Control Register(Default Value: 0x00060000)

Offset: 0x00		Register Name: I2S/PCM_CTL	
Bit	R/W	Default/Hex	Description

31:19	/	/	/
18	R/W	1	BCLK_OUT 0: input 1: output
17	R/W	1	LRCK_OUT 0: input 1: output
16	R/W	0	/
15:12	/	/	/
11	R/W	0	/
10	R/W	0	/
9	R/W	0	/
8	R/W	0	SD00_EN 0: Disable, Hi-Z state 1: Enable
7	/	/	/
6	R/W	0	OUT Mute 0: normal transfer 1: force DOUT to output 0
5:4	R/W	0	MODE_SEL Mode Selection 0: PCM mode (offset 0: DSP_B; offset 1: DSP_A) 1: Left mode (offset 0: LJ mode; offset 1: I2S mode) 2: Right-Justified mode 3: Reserved
3	R/W	0	LOOP Loop back test 0: Normal mode 1: Loop back test When set '1', connecting the SD00 with the SDI
2	R/W	0	TXEN Transmitter Block Enable 0: Disable 1: Enable
1	R/W	0	RXEN Receiver Block Enable 0: Disable 1: Enable
0	R/W	0	GEN Globe Enable A disable on this bit overrides any other block or channel enables. 0: Disable 1: Enable

7.6.7.2. I2S/PCM Format Register0 (Default Value: 0x00000033)

Offset: 0x04			Register Name: I2S/PCM_FMT0
Bit	R/W	Default/Hex	Description
31	R/W	0	/
30	R/W	0	LRCK_WIDTH (only apply in PCM mode) LRCK width 0: LRCK = 1 BCLK width (short frame) 1: LRCK = 2 BCLK width (long frame)
29:20	R/W	0	/
19	R/W	0	LRCK_POLARITY/LRCKR_POLARITY When apply in I2S / Left-Justified / Right-Justified mode: 0: Left channel when LRCK is low 1: Left channel when LRCK is high When apply in PCM mode: 0: PCM LRCK/LRCKR asserted at the negative edge 1: PCM LRCK/LRCKR asserted at the positive edge
18	/	/	/
17:8	R/W	0	LRCK_PERIOD It is used to program the number of BCLKs per channel of sample frame. This value is interpreted as follow: PCM mode: Number of BCLKs within (Left + Right) channel width I2S / Left-Justified / Right-Justified mode: Number of BCLKs within each individual channel width (Left or Right) N+1 For example: n = 7: 8 BCLK width ... n = 1023: 1024 BCLKs width
7	R/W	0	BCLK_POLARITY 0: normal mode, negative edge drive and positive edge sample 1: invert mode, positive edge drive and negative edge sample
6:4	R/W	3	SR Sample Resolution 0: Reserved 1: 8-bit 2: 12-bit 3: 16-bit 4: 20-bit 5: 24-bit 6: 28-bit 7: 32-bit
3	R/W	0	EDGE_TRANSFER

			0: SDO drive data and SDI sample data at the different BCLK edge 1: SDO drive data and SDI sample data at the same BCLK edge BCLK_POLARITY = 0, use negative edge BCLK_POLARITY = 1, use positive edge
2:0	R/W	0x3	SW Slot Width Select 0: Reserved 1: 8-bit 2: 12-bit 3: 16-bit 4: 20-bit 5: 24-bit 6: 28-bit 7: 32-bit

7.6.7.3. I2S/PCM Format Register1 (Default Value: 0x00000030)

Offset: 0x08			Register Name: I2S/PCM_FMT1
Bit	R/W	Default/Hex	Description
31:8	/	/	
7	R/W	0	RX MLS MSB / LSB First Select 0: MSB First 1: LSB First
6	R/W	0	TX MLS MSB / LSB First Select 0: MSB First 1: LSB First
5:4	R/W	3	SEXT Sign Extend in slot [sample resolution < slot width] 0: Zeros or audio gain padding at LSB position 1: Sign extension at MSB position 2: Reserved 3: Transfer 0 after each sample in each slot
3:2	R/W	0	RX_PDM PCM Data Mode 0: Linear PCM 1: reserved 2: 8-bits u-law 3: 8-bits A-law
1:0	R/W	0	TX_PDM PCM Data Mode 0: Linear PCM

			1: reserved 2: 8-bits u-law 3: 8-bits A-law
--	--	--	---

7.6.7.4. I2S/PCM Interrupt Status Register(Default Value: 0x00000010)

Offset: 0x0C			Register Name: I2S/PCM_ISTA
Bit	R/W	Default/Hex	Description
31:7	/	/	/
6	R/W	0	TXU_INT TX FIFO Under run Pending Interrupt 0: No Pending Interrupt 1: FIFO Under run Pending Interrupt Write 1 to clear this interrupt
5	R/W	0	TXO_INT TX FIFO Overrun Pending Interrupt 0: No Pending Interrupt 1: FIFO Overrun Pending Interrupt Write '1' to clear this interrupt
4	R/W	1	TXE_INT TX FIFO Empty Pending Interrupt 0: No Pending IRQ 1: FIFO Empty Pending Interrupt when data in TX FIFO are less than TX trigger level Write '1' to clear this interrupt or automatic clear if interrupt condition fails.
3	/	/	/
2	R/W	0	RXU_INT RX FIFO Under run Pending Interrupt 0: No Pending Interrupt 1:FIFO Under run Pending Interrupt Write 1 to clear this interrupt
1	R/W	0	RXO_INT RX FIFO Overrun Pending Interrupt 0: No Pending IRQ 1: FIFO Overrun Pending IRQ Write '1' to clear this interrupt
0	R/W	0	RXA_INT RX FIFO Data Available Pending Interrupt 0: No Pending IRQ 1: Data Available Pending IRQ when data in RX FIFO are more than RX trigger level Write '1' to clear this interrupt or automatic clear if interrupt condition

			fails.
--	--	--	--------

7.6.7.5. I2S/PCM RX FIFO Register(Default Value: 0x00000000)

Offset: 0x10			Register Name: I2S/PCM_RXFIFO
Bit	R/W	Default/Hex	Description
31:0	R	0	RX_DATA RX Sample Host can get one sample by reading this register. The left channel sample data is first and then the right channel sample.

7.6.7.6. I2S/PCM FIFO Control Register (Default Value: 0x000400F0)

Offset: 0x14			Register Name: I2S/PCM_FCTL
Bit	R/W	Default/Hex	Description
31	R/W	0	HUB_EN Audio hub enable 0:disable 1:enable
30:26	/	/	/
25	R/W	0	FTX Write '1' to flush TX FIFO, self clear to '0'.
24	R/W	0	FRX Write '1' to flush RX FIFO, self clear to '0'.
23:19	/	/	/
18:12	R/W	0x40	TXTL TX FIFO Empty Trigger Level Interrupt and DMA request trigger level for TXFIFO normal condition Trigger Level = TXTL
11:10	/	/	/
9:4	R/W	0xF	RXTL RX FIFO Trigger Level Interrupt and DMA request trigger level for RXFIFO normal condition Trigger Level = RXTL + 1
3	/	/	/
2	R/W	0	TXIM TX FIFO Input Mode (Mode 0, 1) 0: Valid data at the MSB of TXFIFO register 1: Valid data at the LSB of TXFIFO register Example for 20-bits transmitted audio sample: Mode 0: FIFO_I[31:0] = {APB_WDATA[31:12], 12'h0}

			Mode 1: FIFO_I[31:0] = {APB_WDATA[19:0], 12'h0}
1:0	R/W	0	<p>RXOM RX FIFO Output Mode (Mode 0, 1, 2, 3)</p> <p>00: Expanding '0' at LSB of DA_RXFIFO register. 01: Expanding received sample sign bit at MSB of DA_RXFIFO register. 10: Truncating received samples at high half-word of DA_RXFIFO register and low half-word of DA_RXFIFO register is filled by '0'. 11: Truncating received samples at low half-word of DA_RXFIFO register and high half-word of DA_RXFIFO register is expanded by its sign bit.</p> <p>Example for 20-bits received audio sample: Mode 0: APB_RDATA[31:0] = {FIFO_O[31:12], 12'h0} Mode 1: APB_RDATA [31:0] = {12{FIFO_O[31]}, FIFO_O[31:12]} Mode 2: APB_RDATA [31:0] = {FIFO_O[31:16], 16'h0} Mode 3: APB_RDATA [31:0] = {16{FIFO_O[31]}, FIFO_O[31:16]}</p>

7.6.7.7. I2S/PCM FIFO Status Register (Default Value: 0x10800000)

Offset: 0x18			Register Name: I2S/PCM_FSTA
Bit	R/W	Default/Hex	Description
31:29	/	/	/
28	R	1	<p>TXE TX FIFO Empty 0: No room for new sample in TX FIFO 1: More than one room for new sample in TX FIFO (>= 1 word)</p>
27:24	/	/	/
23:16	R	0x80	<p>TXE_CNT TX FIFO Empty Space Word Counter</p>
15:9	/	/	/
8	R	0	<p>RXA RX FIFO Available 0: No available data in RX FIFO 1: More than one sample in RX FIFO (>= 1 word)</p>
7	/	/	/
6:0	R	0	<p>RXA_CNT RX FIFO Available Sample Word Counter</p>

7.6.7.8. I2S/PCM DMA & Interrupt Control Register(Default Value: 0x00000000)

Offset: 0x1C			Register Name: I2S/PCM_INT
Bit	R/W	Default/Hex	Description
31:8	/	/	/

7	R/W	0	TX_DRQ TX FIFO Empty DRQ Enable 0: Disable 1: Enable
6	R/W	0	TXUI_EN TX FIFO Under run Interrupt Enable 0: Disable 1: Enable
5	R/W	0	TXOI_EN TX FIFO Overrun Interrupt Enable 0: Disable 1: Enable When set to '1', an interrupt happens when writing new audio data if TX FIFO is full.
4	R/W	0	TXEI_EN TX FIFO Empty Interrupt Enable 0: Disable 1: Enable
3	R/W	0	RX_DRQ RX FIFO Data Available DRQ Enable 0: Disable 1: Enable When set to '1', RXFIFO DMA Request line is asserted if Data is available in RX FIFO.
2	R/W	0	RXUI_EN RX FIFO Under run Interrupt Enable 0: Disable 1: Enable
1	R/W	0	RXOI_EN RX FIFO Overrun Interrupt Enable 0: Disable 1: Enable
0	R/W	0	RXAI_EN RX FIFO Data Available Interrupt Enable 0: Disable 1: Enable

7.6.7.9. I2S/PCM TX FIFO Register(Default Value: 0x00000000)

Offset: 0x20			Register Name: I2S/PCM_TXFIFO
Bit	R/W	Default/Hex	Description
31:0	W	0	TX_DATA TX Sample

		Transmitting left, right channel sample data should be written this register one by one. The left channel sample data is first and then the right channel sample.
--	--	---

7.6.7.10. I2S/PCM Clock Divide Register(Default Value: 0x00000000)

Offset: 0x24			Register Name: I2S/PCM_CLKD
Bit	R/W	Default/Hex	Description
31:9	/	/	/
8	R/W	0	<p>MCLKO_EN</p> <p>0: Disable MCLK Output</p> <p>1: Enable MCLK Output</p> <p>Notes: Whether in Slave or Master mode, when this bit is set to 1, MCLK should be output.</p>
7:4	R/W	0	<p>BCLKDIV</p> <p>BCLK Divide Ratio from PLL2</p> <p>0: reserved</p> <p>1: Divide by 1</p> <p>2: Divide by 2</p> <p>3: Divide by 4</p> <p>4: Divide by 6</p> <p>5: Divide by 8</p> <p>6: Divide by 12</p> <p>7: Divide by 16</p> <p>8: Divide by 24</p> <p>9: Divide by 32</p> <p>10: Divide by 48</p> <p>11: Divide by 64</p> <p>12: Divide by 96</p> <p>13: Divide by 128</p> <p>14: Divide by 176</p> <p>15: Divide by 192</p>
3:0	R/W	0	<p>MCLKDIV</p> <p>MCLK Divide Ratio from PLL2 Output</p> <p>0: reserved</p> <p>1: Divide by 1</p> <p>2: Divide by 2</p> <p>3: Divide by 4</p> <p>4: Divide by 6</p> <p>5: Divide by 8</p> <p>6: Divide by 12</p> <p>7: Divide by 16</p> <p>8: Divide by 24</p>

			9: Divide by 32
			10: Divide by 48
			11: Divide by 64
			12: Divide by 96
			13: Divide by 128
			14: Divide by 176
			15: Divide by 192

7.6.7.11. I2S/PCM TX Counter Register(Default Value: 0x00000000)

Offset: 0x28			Register Name: I2S/PCM_TXCNT
Bit	R/W	Default/Hex	Description
31:0	R/W	0	TX_CNT TX Sample Counter The audio sample number of sending into TXFIFO. When one sample is put into TXFIFO by DMA or by host IO, the TX sample counter register increases by one. The TX sample counter register can be set to any initial value at any time. After been updated by the initial value, the counter register should count on base of this initial value.

7.6.7.12. I2S/PCM RX Counter Register(Default Value: 0x00000000)

Offset: 0x2C			Register Name: I2S/PCM_RXCNT
Bit	R/W	Default/Hex	Description
31:0	R/W	0	RX_CNT RX Sample Counter The audio sample number of writing into RXFIFO. When one sample is written by Digital Audio Engine, the RX sample counter register increases by one. The RX sample counter register can be set to any initial value at any time. After been updated by the initial value, the counter register should count on base of this initial value.

7.6.7.13. I2S/PCM Channel Configuration Register(Default Value: 0x00000000)

Offset: 0x30			Register Name: I2S/PCM_CHCFG
Bit	R/W	Default/Hex	Description
31:10	/	/	/
9	R/W	0	TX_SLOT_HIZ 0: normal mode for the last half cycle of BCLK in the slot 1: turn to hi-z state for the last half cycle of BCLK in the slot

			TXn_STATE 0: transfer level 0 when not transferring slot 1: turn to hi-z state when not transferring slot
8	R/W	0	
7	/	/	/
			RX_SLOT_NUM RX Channel/Slot Number which between CPU/DMA and FIFO 0: 1 channel or slot ... 7: 8 channels or slots
6:4	R/W	0	
3	/	/	/
			TX_SLOT_NUM TX Channel/Slot Number which between CPU/DMA and FIFO 0: 1 channel or slot ... 7: 8 channels or slots
2:0	R/W	0	

7.6.7.14. I2S/PCM TXn Channel Select Register(Default Value: 0x00000000)

Offset: 0x34 + n*4 (n = 0, 1, 2, 3)			Register Name: I2S/PCM_TXnCHSEL
Bit	R/W	Default/Hex	Description
31:14	/	/	/
13:12	R/W	0	TXn_OFFSET TXn offset tune, TXn data offset to LRCK 0: no offset n: data is offset by n BCLKs to LRCK
11:4	R/W	0	TXn_CHEN TXn Channel (slot) enable, bit[11:4] refer to slot [7:0]. When one or more slot(s) is(are) disabled, the affected slot(s) is(are) set to disable state 0: disable 1: enable
3	/	/	/
			TXn_CHSEL TXn Channel (slot) number Select for each output 0: 1 channel / slot ... 7: 8 channels / slots
2:0	R/W	0	

7.6.7.15. I2S/PCM TXn Channel Mapping Register(Default Value: 0x00000000)

Offset: 0x44 + n*4 (n = 0, 1, 2, 3)	Register Name: I2S/PCM_TXnCHMAP
-------------------------------------	--

Bit	R/W	Default/Hex	Description
31	/	/	/
30:28	R/W	0	TXn_CH7_MAP TXn Channel7 Mapping 0: 1st sample ... 7: 8th sample
27	/	/	/
26:24	R/W	0	TXn_CH6_MAP TXn Channel6 Mapping 0: 1st sample ... 7: 8th sample
23	/	/	/
22:20	R/W	0	TXn_CH5_MAP TXn Channel5 Mapping 0: 1st sample ... 7: 8th sample
19	/	/	/
18:16	R/W	0	TXn_CH4_MAP TXn Channel4 Mapping 0: 1st sample ... 7: 8th sample
15	/	/	/
14:12	R/W	0	TXn_CH3_MAP TXn Channel3 Mapping 0: 1st sample ... 7: 8th sample
11	/	/	/
10:8	R/W	0	TXn_CH2_MAP TXn Channel2 Mapping 0: 1st sample ... 7: 8th sample
7	/	/	/
6:4	R/W	0	TXn_CH1_MAP TXn Channel1 Mapping 0: 1st sample ... 7: 8th sample
3	/	/	/

2:0	R/W	0	TXn_CH0_MAP TXn Channel0 Mapping 0: 1st sample ... 7: 8th sample
-----	-----	---	--

7.6.7.16. I2S/PCM RX Channel Select Register(Default Value: 0x00000000)

Offset: 0x54			Register Name: I2S/PCM_RXCHSEL
Bit	R/W	Default/Hex	Description
31:14	/	/	/
13:12	R/W	0	RX_OFFSET RX offset tune, RX data offset to LRCK 0: no offset n: data is offset by n BCLKs to LRCK
11:3	/	/	
2:0	R/W	0	RX_CHSEL RX Channel (slot) number Select for input 0: 1 channel / slot ... 7: 8 channels / slots

7.6.7.17. I2S/PCM RX Channel Mapping Register(Default Value: 0x00000000)

Offset: 0x58			Register Name: I2S/PCM_RXCHMAP
Bit	R/W	Default/Hex	Description
31	/	/	/
30:28	R/W	0	RX_CH7_MAP RX Channel7 Mapping 0: 1st sample ... 7: 8th sample
27	/	/	/
26:24	R/W	0	RX_CH6_MAP RX Channel6 Mapping 0: 1st sample ... 7: 8th sample
23	/	/	/
22:20	R/W	0	RX_CH5_MAP RX Channel5 Mapping

			0: 1st sample ... 7: 8th sample
19	/	/	/
18:16	R/W	0	RX_CH4_MAP RX Channel4 Mapping 0: 1st sample ... 7: 8th sample
15	/	/	/
14:12	R/W	0	RX_CH3_MAP RX Channel3 Mapping 0: 1st sample ... 7: 8th sample
11	/	/	/
10:8	R/W	0	RX_CH2_MAP RX Channel2 Mapping 0: 1st sample ... 7: 8th sample
7	/	/	/
6:4	R/W	0	RX_CH1_MAP TX Channel1 Mapping 0: 1st sample ... 7: 8th sample
3	/	/	/
2:0	R/W	0	RX_CHO_MAP RX Channel0 Mapping 0: 1st sample ... 7: 8th sample

7.7. OWA

7.7.1. Overview

The OWA(One Wire Audio) provides a serial bus interface for audio data between system. This interface is widely used for consumer audio connect.

The OWA includes the following features:

- IEC-60958 transmitter and receiver functionality
- Complies with SPDIF Interface
- Support channel status insertion for the transmitter
- Hardware Parity generation on the transmitter
- One 32x24bits FIFO (TX) for audio data transfer
- Programmable FIFO thresholds
- Interrupt and DMA support
- Support Audio HUB

7.7.2. Functional Description

7.7.2.1. OWA Interface Pin List

Signal Name	Direction(M)	Description	Pin
OWA_DOUT	O	OWA output	PH8

7.7.2.2. OWA Clock Requirement

Clock Name	Description	Requirement
apb_clk	APB bus clock	>13 MHz
s_clk	OWA serial access clock	4x24.576 MHz or 4x22.5792 MHz from CCU

7.7.2.3. OWA Block Diagram

Figure 7-13 shows the OWA block diagram.

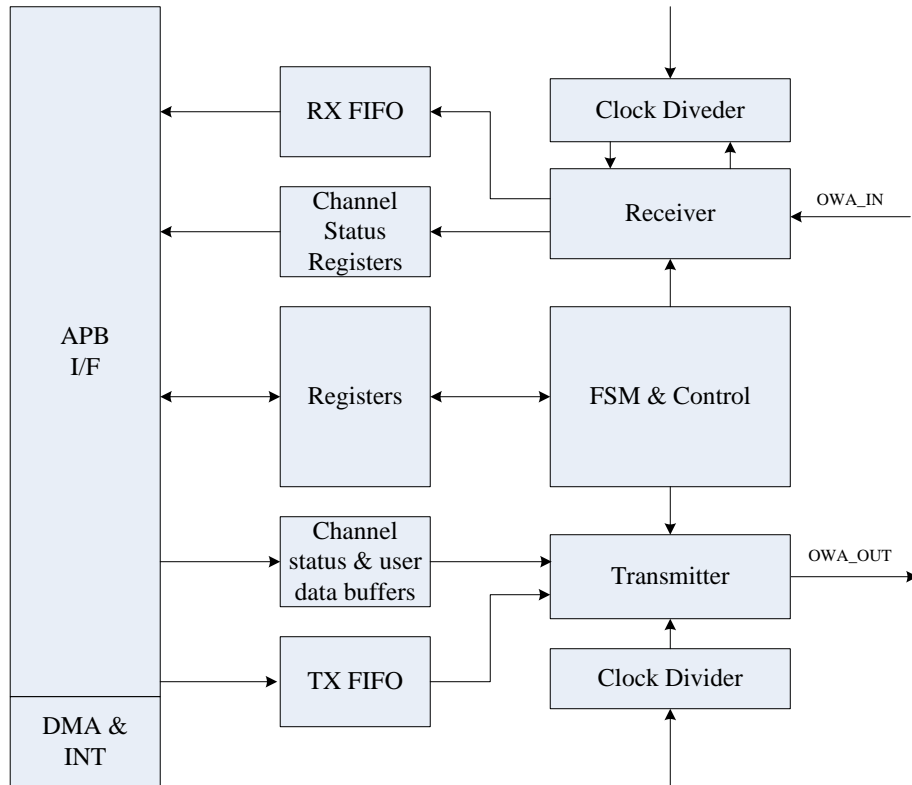

Figure 7-13. OWA Block Diagram

7.7.2.4. OWA Frame Format

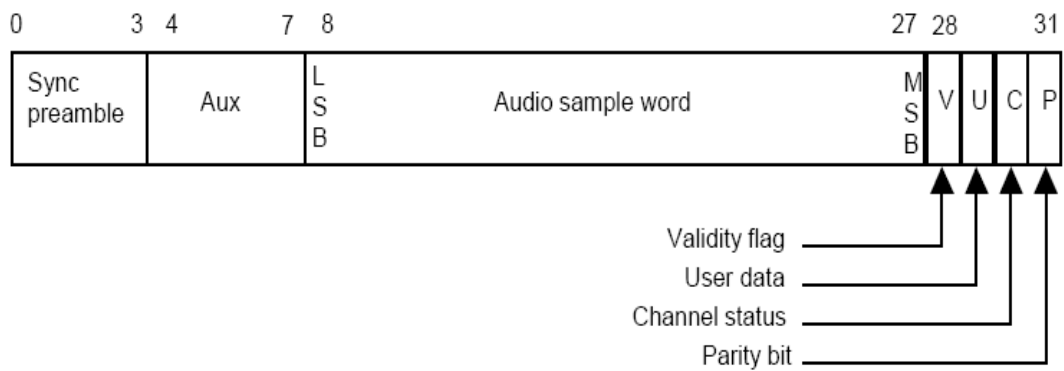

Figure 7-14. Sub-Frame Format

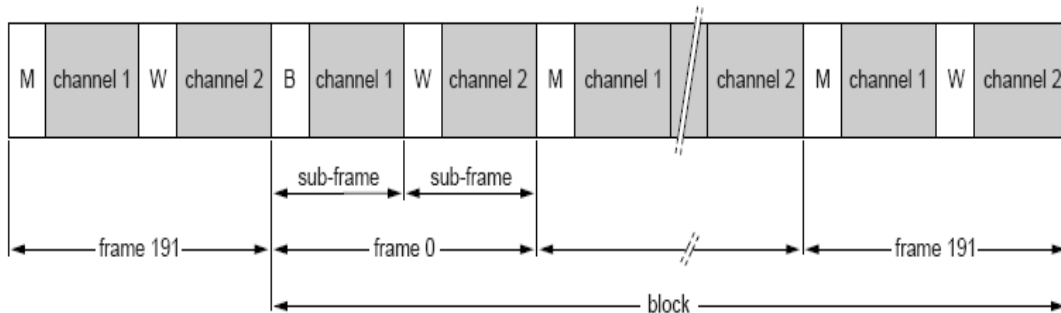

Figure 7-15. Frame/block format

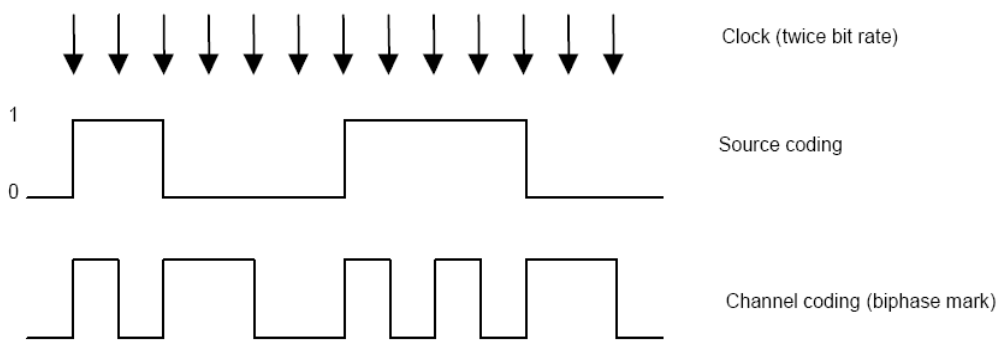

Figure 7-16. Biphase-Mark Encoding

7.7.2.5. Operation Modes

The software operation of the OWA is divided into five steps: system setup, OWA initialization, the channel setup, DMA setup and Enable/Disable module. These five steps are described in detail in the following sections.

7.7.2.5.1. System setup and OWA initialization

The first step in the OWA initialization is properly programming the GPIO. Because the OWA port is a multiplex pin. You can find the function in the [Port Controller\(CPUx-PORT\)](#). The clock source for the OWA should be followed. At first you must reset the audio PLL in the [CCU](#). The second step, you must setup the frequency of the audio pll. After that, you must open the OWA gating. At last, you must open the OWA bus gating.

After the system setup, the register of OWA can be setup. At first, you should reset the OWA by write 1 to [OWA_CTL\[0\]](#) and clear the TX/RX FIFO by write 1 to register [OWA_FCTL\[17:16\]](#). After that you should enable the globe enable bit by write 1 to [OWA_CTL\[1\]](#) and clear the interrupt and TX/RX counter through the [OWA_ISTA](#) and [OWA_TX_CNT/OWA_RX_CNT](#).

7.7.2.5.2. The channel setup and DMA setup

The OWA support three methods to transfer the data. The most common way is DMA, the set of DMA can be found in the [DMA](#). In this module, you just to enable the DRQ.

7.7.2.5.3. Enable and disable the OWA

To enable the function, you can enable TX/RX by writing the [OWA_TX_CFG\[31\]](#) and [OWA_RX_CFG\[0\]](#). After that, you must enable OWA by write the [Globe Enable](#) bit to 1 in the [OWA_CTL](#). Writing the [Globe Enable](#) to 0 disable process.

7.7.3. OWA Register List

Module Name	Base Address
OWA	0x01C21000

Register Name	Offset	Description
OWA_GEN_CTL	0x00	OWA General Control
OWA_TX_CFG	0x04	OWA TX Configuration Register
OWA_RX_CFG	0x08	OWA RX Configuration Register
OWA_ISTA	0x0C	OWA Interrupt Status Register
OWA_RX_FIFO	0x10	OWA RX FIFO Register
OWA_FCTL	0x14	OWA FIFO Control Register
OWA_FSTA	0x18	OWA FIFO Status Register
OWA_INT	0x1C	OWA Interrupt Control Register
OWA_TX_FIFO	0x20	OWA TX FIFO Register
OWA_TX_CNT	0x24	OWA TX Counter Register
OWA_RX_CNT	0x28	OWA RX Counter Register
OWA_TX_CHSTA0	0x2C	OWA TX Channel Status Register0
OWA_TX_CHSTA1	0x30	OWA TX Channel Status Register1
OWA_RX_CHSTA0	0x34	OWA RX Channel Status Register0
OWA_RX_CHSTA1	0x38	OWA RX Channel Status Register1

7.7.4. OWA Register Description

7.7.4.1. OWA General Control Register(Default Value : 0x00000080)

Offset: 0x00			Register Name: OWA_CTL
Bit	R/W	Default/Hex	Description
31:10	/	/	/
9:4	R/W	0x08	MCLK_DIV_RATIO Mclk divide Ratio Note: only support 2 ⁿ divide ratio(n=1~31)
3:2	/	/	/
1	R/W	0	GEN Globe Enable A disable on this bit overrides any other block or channel enables and flushes all FIFOs. 0: Disable 1: Enable
0	R/W	0	RST Reset 0: Normal 1: Reset <i>Self clear to 0</i>

7.7.4.2. OWA TX Configure Register(Default Value: 0x000000F0)

Offset: 0x04			Register Name: OWA_TX_CFG
Bit	R/W	Default/Hex	Description
31	R/W	0	TX_SINGLE_MODE Tx single channel mode 0: Disable 1: Eanble
30:18	/	/	/
17	R/W	0	ASS Audio sample select with TX FIFO under run when 0: sending 0 1: sending the last audio <i>Note: This bit is only valid in PCM mode</i>
16	R/W	0	TX_AUDIO TX data type 0: Linear PCM (Valid bit of both sub-frame set to 0)

			1: Non-audio(Valid bit of both sub-frame set to 1)
15:9	/	/	/
8:4	R/W	0xF	TX_RATIO TX clock divide Ratio <i>Note: clock divide ratio = TX TATIO +1</i>
3:2	R/W	0	TX_SF TX Sample format: 00: 16bit 01: 20bit 10: 24bit 11: Reserved
1	R/W	0	TX_CHM CHSTMODE 0: Channel status A&B set to 0 1: Channel status A&B generated form TX_CHSTA
0	R/W	0	TXEN 0: disabled 1: enabled

7.7.4.3. OWA RX Configure Register(Default Value: 0x00000000)

Offset: 0x08			Register Name: OWA_RX_CFG
Bit	R/W	Default/Hex	Description
31:5	/	/	/
4	R	0	RX_LOCK_FLAG 0: unlock 1: lock
3	R/W	0	RX_CHST_SRC 0: RX_CH_STA Register holds status from Channel A 1: RX_CH_STA Register holds status from Channel B
2	/	/	/
1	R/W	0	CHST_CP Channel status Capture 0: Idle or capture end 1: Capture Channel status start Notes: When set to '1', the channel status information is capturing, the bit will clear to '0' after captured.
0	R/W	0	RXEN 0: disabled 1: enabled

7.7.4.4. OWA Interrupt Status Register(Default Value: 0x00000010)

Offset: 0x0C			Register Name: OWA_ISTA
Bit	R/W	Default/Hex	Description
31:19	/	/	/
18	R/W	0	RX_LOCK_INT 0: No pending IRQ 1: RX lock Pending Interrupt (RX_LOCK_FLAG 0→1) <i>Write "1" to clear this interrupt</i>
17	R/W	0	RX_UNLOCK_INT RX Unlock Pending Interrupt 0: No pending IRQ 1: RX Unlock Pending Interrupt (RX_LOCK_FLAG 1→0) <i>Write "1" to clear this interrupt</i>
16	R/W	0	RX_PARERRI_INT RX Parity Error Pending Interrupt 0: No pending IRQ 1: RX Parity Error Pending Interrupt <i>Write "1" to clear this interrupt</i>
15:7	/	/	/
6	R/W	0	TXU_INT TX FIFO Under run Pending Interrupt 0: No pending IRQ 1: FIFO Under run Pending Interrupt <i>Write "1" to clear this interrupt</i>
5	R/W	0	TXO_INT TX FIFO Overrun Pending Interrupt 0: No Pending IRQ 1: FIFO Overrun Pending Interrupt <i>Write "1" to clear this interrupt</i>
4	R/W	1	TXE_INT TX FIFO Empty Pending Interrupt 0: No Pending IRQ 1: FIFO Empty Pending Interrupt <i>Write "1" to clear this interrupt or automatically clear if interrupt condition fails.</i>
3:2	/	/	/
1	R/W	0	RXO_INT RX FIFO Overrun Pending Interrupt 0: FIFO Overrun Pending <i>Write "1" to clear this interrupt</i>
0	R/W	0	RXA_INT RX FIFO Available Pending Interrupt

			<p>0: No Pending IRQ 1: Data Available Pending IRQ <i>Write "1" to clear this interrupt or automatically clear if interrupt condition fails</i></p>
--	--	--	---

7.7.4.5. OWA RX FIFO Register(Default Value: 0x00000000)

Offset: 0x10			Register Name: OWA_RXFIFO
Bit	R/W	Default/Hex	Description
31:0	R	0	<p>RX_DATA Host can get one sample by reading this register, the A channel data is first and then the B channel data</p>

7.7.4.6. OWA FIFO Control Register(Default Value: 0x00001078)

Offset: 0x14			Register Name: OWA_FCTL
Bit	R/W	Default/Hex	Description
31	R/W	0	<p>HUB_EN Audio hub enable 0 : Disable 1: Enable</p>
30:18	/	/	/
17	R/W	0	<p>FTX Write "1" to flush TX FIFO, self clear to "0"</p>
16	R/W	0	<p>FRX Write "1" to flush RX FIFO, self clear to "0"</p>
15:13	/	/	/
12:8	R/W	0x10	<p>TXTL TX FIFO empty Trigger Level Interrupt and DMA request trigger level for TX FIFO normal condition Trigger Level = TXTL</p>
7:3	R/W	0x0F	<p>RXTL RX FIFO Trigger Level Interrupt and DMA request trigger level for RX FIFO normal condition Trigger Level = RXTL + 1</p>
2	R/W	0	<p>TXIM TX FIFO Input Mode(Mode0, 1) 0: Valid data at the MSB of OWA_TXFIFO register 1: Valid data at the LSB of OWA_TXFIFO register Example for 20-bits transmitted audio sample: Mode 0: FIFO_I[23:0] = {TXFIFO[31:12], 4'h0}</p>

			Mode 1: FIFO_I[23:0] = {TXFIFO[19:0], 4'h0}
1:0	R/W	0	<p>RXOM RX FIFO Output Mode(Mode 0,1,2,3)</p> <p>00: Expanding "0" at LSB of SPDIP_RXFIFO register</p> <p>01: Expanding received sample sign bit at MSB of OWA_RXFIFO register</p> <p>10: Truncating received samples at high half-word of OWA_RXFIFO register and low half-word of AC_FIFO register is filled by "0"</p> <p>11: Truncating received samples at low half-word of OWA_RXFIFO register and high half-word of AC_FIFO register is expanded by its sign bit</p> <p>Mode0: RXFIFO[31:0] = {FIFO_O[23:0], 8'h0}</p> <p>Mode 1: RXFIFO[31:0] = {8'FIFO_O[23], FIFO_O[23:0]}</p> <p>Mode 2: RXFIFO[31:0] = {FIFO_O[23:8], 16'h0}</p> <p>Mode 3: RXFIFO[31:0] = {16'FIFO_O[23], FIFO_O[23:8]}</p>

7.7.4.7. OWA FIFO Status Register(Default Value: 0x00006000)

Offset: 0x18			Register Name: OWA_FSTA
Bit	R/W	Default/Hex	Description
31:15	/	/	/
14	R	1	<p>TXE TX FIFO Empty (indicate FIFO is not full)</p> <p>0: No room for new sample in TX FIFO</p> <p>1: More than one room for new sample in TX FIFO (>=1 word)</p>
13:8	R	0x20	<p>TXE_CNT TX FIFO Empty Space Word counter</p>
7	/	/	/
6	R	0	<p>RXA RX FIFO Available</p> <p>0: No available data in RX FIFO</p> <p>1: More than one sample in RX FIFO (>=1 word)</p>
5:0	R	0	<p>RXA_CNT RX FIFO Available Sample Word counter</p>

7.7.4.8. OWA Interrupt Control Register(Default Value: 0x00000000)

Offset: 0x1C			Register Name: OWA_INT
Bit	R/W	Default/Hex	Description
31:19	/	/	/
18	R/W	0	RX_LOCKI_EN

			RX LOCK Interrupt enable 0: Disable 1: Enable
17	R/W	0	RX_UNLOCKI_EN RX UNLOCK Interrupt enable 0: Disable 1: Enable
16	R/W	0	RX_PARERRI_EN RX PARITY ERORR Interrupt enable 0: Disable 1: Enable
15:8	/	/	/
7	R/W	0	TX_DRQ TX FIFO Empty DRQ Enable 0: Disable 1: Enable
6	R/W	0	TXUI_EN TX FIFO Under run Interrupt Enable 0: Disable 1: Enable
5	R/W	0	TXOI_EN TX FIFO Overrun Interrupt Enable 0: Disable 1: Enable
4	R/W	0	TXEI_EN TX FIFO Empty Interrupt Enable 0: Disable 1: Enable
3	/	/	/
2	R/W	0	RX_DRQ RX FIFO Data Available DRQ Enable When set to "1", RX FIFO DMA Request is asserted if Data is available in RX FIFO 0: Disable 1: Enable
1	R/W	0	RXOI_EN RX FIFO Overrun Interrupt Enable 0: Disable 1: Enable
0	R/W	0	RXAI_EN RX FIFO Data Available Interrupt Enable 0: Disable 1: Enable

7.7.4.9. OWA TX FIFO Register(Default Value: 0x00000000)

Offset: 0x20			Register Name: OWA_TXFIFO
Bit	R/W	Default/Hex	Description
31:0	W	0	TX_DATA Transmitting A, B channel data should be written this register one by one. The A channel data is first and then the B channel data.

7.7.4.10. OWA TX Counter Register(Default Value: 0x00000000)

Offset: 0x24			Register Name: OWA_TX_CNT
Bit	R/W	Default/Hex	Description
31:0	R/W	0	TX_CNT TX Sample counter The audio sample number of writing into TX FIFO. When one sample is written by DMA or by host IO, the TX sample counter register increases by one. The TX Counter register can be set to any initial value at any time. After been updated by the initial value, the counter register should count on base of this value.

7.7.4.11. OWA RX Counter Register(Default Value: 0x00000000)

Offset: 0x28			Register Name: OWA_RX_CNT
Bit	R/W	Default/Hex	Description
31:0	R/W	0	RX_CNT RX Sample counter The audio sample number of writing into RX FIFO. When one sample is written by Codec, the RX sample counter register increases by one. The RX Counter register can be set to any initial value at any time. After been updated by the initial value, the counter register should count on base of this value.

7.7.4.12. OWA TX Channel Status Register0(Default Value: 0x00000000)

Offset: 0x2C			Register Name: OWA_TX_CHSTAO
Bit	R/W	Default/Hex	Description
31: 30	/	/	/
29:28	R/W	0	CA Clock Accuracy

			<p>00: Level 2 01: Level 1 10: Level 3 11: not matched</p>
27:24	R/W		<p>FREQ Sampling frequency 0000: 44.1kHz 1000: Reserved 0001: not indicated 1001: 768kHz 0010: 48kHz 1010: 96kHz 0011: 32kHz 1011: Reserved 0100: 22.05kHz 1100:176.4kHz 0101: Reserved 1101: Reserved 0110: 24kHz 1110: 192kHz 0111: Reserved 1111: Reserved</p>
23:20	R/W	0	<p>CN Channel Number</p>
19:16	R/W	0	<p>SN Source Number</p>
15:8	R/W	0	<p>CC Category code Indicates the kind of equipment that generates the digital audio interface signal.</p>
7:6	R/W	0	<p>MODE Mode 00: Default Mode 01~11: Reserved</p>
5:3	R/W	0	<p>EMP Emphasis Additional format information For bit 1 = "0", Linear PCM audio mode: 000: 2 audio channels without pre-emphasis 001: 2 audio channels with 50 μs / 15 μs pre-emphasis 010: Reserved (for 2 audio channels with pre-emphasis) 011: Reserved (for 2 audio channels with pre-emphasis) 100~111: Reserved For bit 1 = "1", other than Linear PCM applications: 000: Default state 001~111: Reserved</p>
2	R/W	0	<p>CP Copyright 0: copyright is asserted 1: no copyright is asserted</p>
1	R/W	0	<p>TYPE Audio Data Type</p>

			0: Linear PCM Samples 1: For none-linear PCM audio such as AC3, DTS, MPEG audio
0	R/W	0	PRO Application type 0: Consumer Application 1: Professional Application Note: This bit must be fixed to "0"

7.7.4.13. OWA TX Channel Status Register1(Default Value: 0x00000000)

Offset: 0x30			Register Name: OWA_TX_CHSTA1
Bit	R/W	Default/Hex	Description
31:10	/	/	/
9:8	R/W	0	CGMS_A 00: Copying is permitted without restriction 01: One generation of copies may be made 10: Condition not be used 11: No copying is permitted
7:4	R/W	0	ORIG_FREQ Original sampling frequency 0000: not indicated 0001: 192kHz 0010: 12kHz 0011: 176.4kHz 0100: Reserved 0101: 96kHz 0110: 8kHz 0111: 88.2kHz 1000: 16kHz 1001: 24kHz 1010: 11.025kHz 1011: 22.05kHz 1100: 32kHz 1101: 48kHz 1110: Reserved 1111: 44.1kHz
3:1	R/W	0	WL Sample word length For bit 0 = "0": 000: not indicated 001: 16 bits 010: 18 bits 100: 19 bits

			101: 20 bits 110: 17 bits 111: Reserved For bit 0 = "1": 000: not indicated 001: 20 bits 010: 22 bits 100: 23 bits 101: 24 bits 110: 21 bits 111: Reserved
0	R/W	0	MWL Max Word length 0: Maximum audio sample word length is 20 bits 1: Maximum audio sample word length is 24 bits

7.7.4.14. OWA RX Channel Status Register0(Default Value: 0x00000000)

Offset: 0x34			Register Name: OWA_RX_CHSTAO
Bit	R/W	Default/Hex	Description
31:30	/	/	/
29:28	R/W	0	CA Clock Accuracy 00: Level 2 01: Level 1 10: Level 3 11: not matched
27:24	R/W	0	FREQ Sampling frequency 0000: 44.1kHz 1000: Reserved 0001: not indicated 1001: 768kHz 0010: 48kHz 1010: 96kHz 0011: 32kHz 1011: Reserved 0100: 22.05kHz 1100:176.4kHz 0101: Reserved 1101: Reserved 0110: 24kHz 1110: 192kHz 0111: Reserved 1111: Reserved
23:20	R/W	0	CN Channel Number
19:16	R/W	0	SN Source Number
15:8	R/W	0	CC

			Category code Indicates the kind of equipment that generates the digital audio interface signal.
7:6	R/W	0	MODE Mode 00: Default Mode 01~11: Reserved
5:3	R/W	0	EMP Emphasis Additional format information For bit 1 = "0", Linear PCM audio mode: 000: 2 audio channels without pre-emphasis 001: 2 audio channels with 50 μs / 15 μs pre-emphasis 010: Reserved (for 2 audio channels with pre-emphasis) 011: Reserved (for 2 audio channels with pre-emphasis) 100~111: Reserved For bit 1 = "1", other than Linear PCM applications: 000: Default state 001~111: Reserved
2	R/W	0	CP Copyright 0: copyright is asserted 1: no copyright is asserted
1	R/W	0	TYPE Audio Data Type 0: Linear PCM Samples 1: For none-linear PCM audio such as AC3, DTS, MPEG audio
0	R/W	0	PRO Application type 0: Consumer Application 1: Professional Application

7.7.4.15. OWA RX Channel Status Register1(Default Value: 0x00000000)

Offset: 0x38			Register Name: OWA_CH_STA0
Bit	R/W	Default/Hex	Description
31:10	/	/	/
9:8	R/W	0	CGMS_A 00: Copying is permitted without restriction 01: One generation of copies may be made 10: Condition not be used 11: No copying is permitted
7:4	R/W	0	ORIG_FREQ

			<p>Original sampling frequency</p> <p>0000: not indicated</p> <p>0001: 192kHz</p> <p>0010: 12kHz</p> <p>0011: 176.4kHz</p> <p>0100: Reserved</p> <p>0101: 96kHz</p> <p>0110: 8kHz</p> <p>0111: 88.2kHz</p> <p>1000: 16kHz</p> <p>1001: 24kHz</p> <p>1010: 11.025kHz</p> <p>1011: 22.05kHz</p> <p>1100: 32kHz</p> <p>1101: 48kHz</p> <p>1110: Reserved</p> <p>1111: 44.1kHz</p>
3:1	R/W	0	<p>WL</p> <p>Sample word length</p> <p>For bit 0 = "0":</p> <p>000: not indicated</p> <p>001: 16 bits</p> <p>010: 18 bits</p> <p>100: 19 bits</p> <p>101: 20 bits</p> <p>110: 17 bits</p> <p>111: Reserved</p> <p>For bit 0 = "1":</p> <p>000: not indicated</p> <p>001: 20 bits</p> <p>010: 22 bits</p> <p>100: 23 bits</p> <p>101: 24 bits</p> <p>110: 21 bits</p> <p>111: Reserved</p>
0	R/W	0	<p>MWL</p> <p>Max Word length</p> <p>0: Maximum audio sample word length is 20 bits</p> <p>1: Maximum audio sample word length is 24 bits</p>

7.8. SCR

7.8.1. Overview

The Smart Card Reader (SCR) is a communication controller that transmits data between the system and Smart Card. The controller can perform a complete smart card session, including card activation, card deactivation. Cold/warm reset, Answer to Reset (ATR) response reception, data transfers, etc.

The SCR includes the following features:

- Supports APB slave interface for easy integration with AMBA-based host systems
- Supports the ISO/IEC 7816-3:1997(E) and EMV2000 (4.0) Specifications
- Performs functions needed for complete smart card sessions, including:
 - Card activation and deactivation
 - Cold/warm reset
 - Answer to Reset (ATR) response reception
 - Data transfers to and from the card
- Supports adjustable clock rate and bit rate
- Configurable automatic byte repetition
- Support commonly used communication protocols:
 - T=0 for asynchronous half-duplex character transmission
 - T=1 for asynchronous half-duplex block transmission
- Support FIFOs for receive and transmit buffers (up to 128 characters) with threshold
- Support configurable timing functions:
 - Smart card activation time
 - Smart card reset time
 - Guard time
 - Timeout timers
- Supports synchronous and any other non-ISO 7816 and non-EMV cards

7.8.2. Block Diagram

The Top Diagram of Smart Card Reader is below:

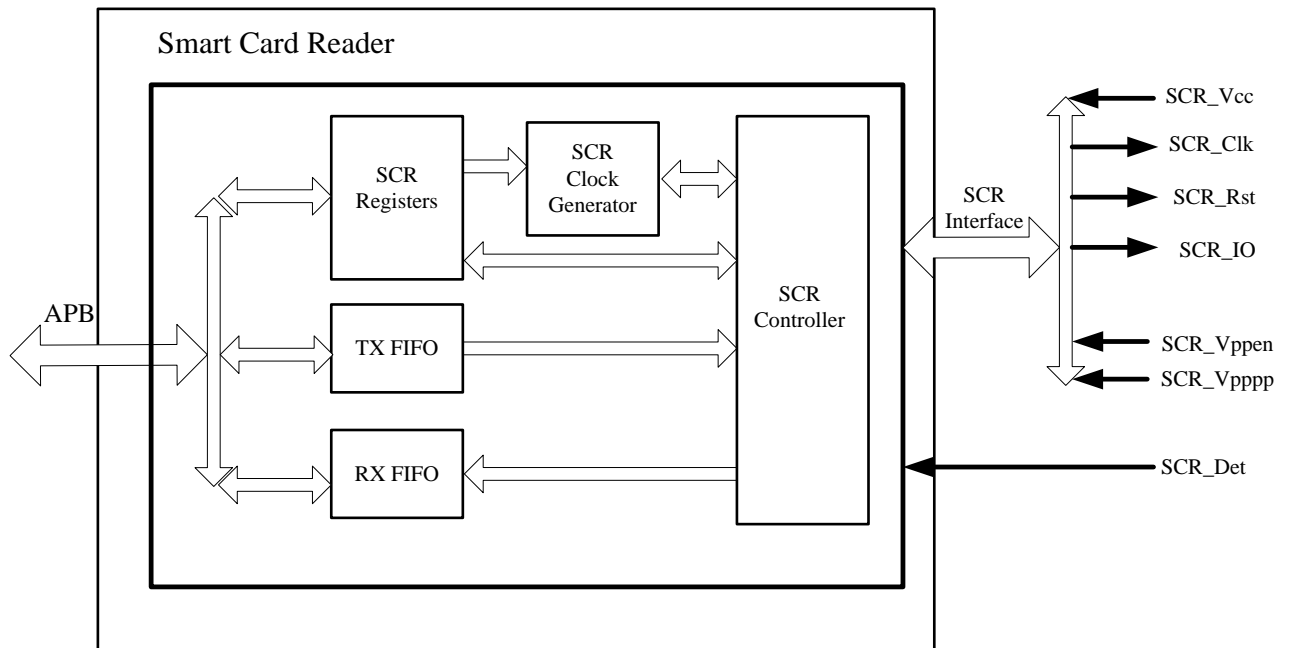

Figure 7-17. SCR Block Diagram

7.8.3. SCR Timing Diagram

Please refer ISO/IEC 7816 and EMV2000 Specification.

7.8.4. SCR Special Requirement

7.8.4.1. Clock Generator

The Clock Generator generates the Smart Card Clock signal and the Baud Clock Impulse signal, used in timing the Smart Card Reader.

The Smart Card Clock signal is used as the main clock for the smart card. Its frequency can be adjusted using the Smart Card Clock Divisor (SCCDIV). This value is used to divide the system clock. The SCCLK frequency is given by the following equation:

$$f_{scclk} = \frac{f_{sysclk}}{2 * (SCCDIV + 1)}$$

f_{scclk} -- Smart Card Clock Frequency

f_{sysclk} -- System Clock (PCLK) Frequency

The **Baud Clock Impulse** signal is used to transmit and receive serial between the Smart Card Reader and the Smart Card. The baud rate can be modified using the Baud Clock Divisor (BAUDDIV). The value is used to divide the system clock. The BAUD rate is given by the following equation:

$$BAUD = \frac{f_{sysclk}}{2 * (BAUDDIV + 1)}$$

BAUD -- Baud rate of the data stream between Smart Card and Reader.

The duration of one bit, Elementary Time Unit (ETU), is defined in the ISO/IEC 7816-3 specification. During the first answer to reset response after the cold reset, the initial ETU must be equal to 372 Smart Card Clock Cycles.

$$\frac{1}{BAUD} = ETU = \frac{372}{f_{scclk}}$$

In this case, the BAUDDIV should be

$$BAUDDIV = \frac{372 * f_{sysclk}}{2 * f_{scclk}} - 1 = 372 * (SCCDIV + 1) - 1 .$$

After the ATR is completed, the ETU can be changed according to Smart Card abilities.

$$\frac{1}{BAUD} = ETU = \frac{F}{D} * \frac{1}{f_{scclk}}$$

Parameters F and D are defined in the ISO/IEC 7816-3 Specification.

7.8.4.2. SCIO Pad Configuration

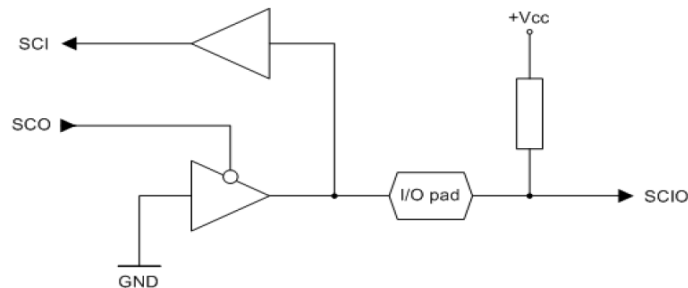

Figure 7-18. SCIO Pad Configuration Diagram

7.8.5. SCR Register List

Module Name	Base Address
SCR	0x01C2C400

Register Name	Offset	Description
SCR_CSR	0x000	Smart Card Reader Control and Status Register
SCR_INTEN	0x004	Smart Card Reader Interrupt Enable Register 1
SCR_INTST	0x008	Smart Card Reader Interrupt Status Register 1
SCR_FCSR	0x00c	Smart Card Reader FIFO Control and Status Register
SCR_FCNT	0x010	Smart Card Reader RX and TX FIFO Counter Register
SCR_RPT	0x014	Smart Card Reader RX and TX Repeat Register
SCR_DIV	0x018	Smart Card Reader Clock and Baud Divisor Register
SCR_LTIM	0x01c	Smart Card Reader Line Time Register
SCR_CTIM	0x020	Smart Card Reader Character Time Register
SCR_LCTLR	0x030	Smart Card Reader Line Control Register
SCR_FSM	0x03c	Smart Card Reader FSM Register
SCR_FIFO	0x100	Smart Card Reader RX and TX FIFO Access Point

7.8.6. SCR Register Description

7.8.6.1. Smart Card Reader Control and Status Register(Default Value: 0x00000000)

Offset: 0x00			Register Name: SCR_CSR
Bit	R/W	Default/Hex	Description
31	R	0	SCDET Smart Card Detected This bit is set to '1' when the <i>scdetect</i> input is active at least for a debounce time.
30	/	/	/
24	R/W	0	SCDETPOL Smart Card Detect Polarity This bit set polarity of <i>scdetect</i> signal. 0: Low Active 1: High Active
23:22	R/W	0	Protocol Selection (PTLSEL) 0x0 : T=0. 0x1 : T=1, no character repeating and no guard time is used when T=1 protocol is selected. 0x2 : Reserved 0x3 : Reserved

21	R/W	0	<p>ATRSTFLUSH ATR Start Flush FIFO</p> <p>When enabled, both FIFOs are flushed before the ATR is started.</p>
20	R/W	0	<p>TSRXE TS Receive Enable</p> <p>When set to '1', the TS character (the first ATR character) will be store in RXFIFO during card session.</p>
19	R/W	0	<p>CLKSTPPOL Clock Stop Polarity</p> <p>The value of the scclk output during the clock stop state.</p>
18	R/W	0	<p>PECRXE Parity Error Character Receive Enable</p> <p>Enables storage of the characters received with wrong parity in RX FIFO.</p>
17	R/W	0	<p>MSBF MSB First</p> <p>When high, inverse bit ordering convention (msb to lsb) is used.</p>
16	R/W	0	<p>DATAPOL Data Plorarity</p> <p>When high, inverse level convention is used (A='1', Z='0').</p>
15:12	/	/	/
11	R/W	0	<p>DEACTDeactivation. Setting of this bit initializes the deactivation sequence. When the deactivation is finished, the DEACT bit is automatically cleared.</p>
10	R/W	0	<p>ACT Activation. Setting of this bit initializes the activation sequence. When the activation is finished, the ACT bit is automatically cleared.</p>
9	R/W	0	<p>WARMRST Warm Reset Command. Writing '1' to this bit initializes Warm Reset of the Smart Card. This bit is always read as '0'.</p>
8	R/W	0	<p>CLKSTOP Clock Stop. When this bit is asserted and the smart card I/O line is in 'Z' state, the SCR core stops driving of the smart card clock signal after the CLKSTOPDELAY time expires. The smart card clock is restarted immediately after the CLKSTOP signal is deasserted. New character transmission can be started after CLKSTARTDELAY time. The expiration of both times is signaled by the CLKSTOPRUN bit in the interrupt registers.</p>
7:3	/	/	Reserved
2	R/W	0	<p>GINTEN Global Interrupt Enable. When high, IRQ output assertion is enabled.</p>
1	R/W	0	<p>RXEN Receiving Enable. When enabled the characters sent by the Smart Card are received by the UART and stored in RX FIFO. Receiving is internally disabled while a transmission is in progress.</p>

0	R/W	0	TXEN Transmission Enable. When enabled the characters are read from TX FIFO and transmitted through UART to the Smart Card.
---	-----	---	--

7.8.6.2. Smart Card Reader Interrupt Enable Register(Default Value: 0x00000000)

Offset: 0x04			Register Name: SCR_INTEN
Bit	R/W	Default/Hex	Description
31:24	/	/	/
23	R/W	0	SCDEA Smart Card Deactivation Interrupt Enable.
22	R/W	0	SCACT Smart Card Activation Interrupt Enable.
21	R/W	0	SCINS Smart Card Inserted Interrupt Enable.
20	R/W	0	SCREM Smart Card Removed Interrupt Enable.
19	R/W	0	ATRDONE ATR Done Interrupt Enable.
18	R/W	0	ATRFAIL ATR Fail Interrupt Enable.
17	R/W	0	C2CFULL Two Consecutive Characters Limit Interrupt Enable.
16	R/W	0	CLKSTOPRUN Smart Card Clock Stop/Run Interrupt Enable.
15:13	/	/	/
12	R/W	0	RXPERR RX Parity Error Interrupt Enable.
11	R/W	0	RXDONE RX Done Interrupt Enable.
10	R/W	0	RXFIFOTH RX FIFO Threshold Interrupt Enable.
9	R/W	0	RXFIFOFULL RX FIFO Full Interrupt Enable.
8	/	/	/
7:5	/	/	/
4	R/W	0	TXPERR TX Parity Error Interrupt Enable.
3	R/W	0	TXDONE TX Done Interrupt Enable.
2	R/W	0	TXFIFOTH TX FIFO Threshold Interrupt Enable.

1	R/W	0	TXFIFOEMPTY TX FIFO Empty Interrupt Enable.
0	R/W	0	TXFIFODONE TX FIFO Done Interrupt Enable.

7.8.6.3. Smart Card Reader Interrupt Status Register(Default Value: 0x00000000)

Offset: 0x08			Register Name: SCR_INTST
Bit	R/W	Default/Hex	Description
31:24	/	/	/
23	R/W	0	SCDEA Smart Card Deactivation Interrupt. When enabled, this interrupt is asserted after the Smart Card deactivation sequence is complete.
22	R/W	0	SCACT Smart Card Activation Interrupt. When enabled, this interrupt is asserted after the Smart Card activation sequence is complete.
21	R/W	0	SCINS Smart Card Inserted Interrupt. When enabled, this interrupt is asserted after the smart card insertion.
20	R/W	0	SCREM Smart Card Removed Interrupt. When enabled, this interrupt is asserted after the smart card removal.
19	R/W	0	ATRDONE ATR Done Interrupt. When enabled, this interrupt is asserted after the ATR sequence is successfully completed.
18	R/W	0	ATRFAIL ATR Fail Interrupt. When enabled, this interrupt is asserted if the ATR sequence fails.
17	R/W	0	C2CFULL Two Consecutive Characters Limit Interrupt. When enabled, this interrupt is asserted if the time between two consecutive characters, transmitted between the Smart Card and the Reader in both directions, is equal the Two Characters Delay Limit described below. The C2CFULL interrupt is internally enabled from the ATR start to the deactivation or ATR restart initialization. It is recommended to use this counter to detect unresponsive Smart Cards.
16	R/W	0	CLKSTOPRUN Smart Card Clock Stop/Run Interrupt. When enabled, this interrupt is asserted in two cases: <ul style="list-style-type: none"> ● When the smart card clock is stopped. ● When the new character can be started after the clock restart. To distinguish between the two interrupt cases, we recommend reading the CLKSTOP bit in SCR_CTRL1 register.

15:13	/	/	/
12	R/W	0	RXPERR RX Parity Error Interrupt. When enabled, this interrupt is asserted after the character with wrong parity was received when the number of repeated receptions exceeds RXREPEAT value or T=1 protocol is used.
11	R/W	0	RXDONE RX Done Interrupt. When enabled, this interrupt is asserted after a character was received from the Smart Card.
10	R/W	0	RXFIFOTHD RX FIFO Threshold Interrupt. When enabled, this interrupt is asserted if the number of bytes in RX FIFO is equal or exceeds the RX FIFO threshold.
9	R/W	0	RXFIFOFULL RX FIFO Full Interrupt. When enabled, this interrupt is asserted if the RX FIFO is filled up.
8	/	/	/
7:5	/	/	/
4	R/W	0	TXPERR TX Parity Error Interrupt. When enabled, this interrupt is asserted if the Smart Card signals wrong character parity during the guard time after the character transmission was repeated TXREPEAT times or T=1 protocol is used.
3	R/W	0	TXDONE TX Done Interrupt. When enabled, this interrupt is asserted after one character was transmitted to the smart card.
2	R/W	0	TXFIFOTHD TX FIFO Threshold Interrupt. When enabled, this interrupt is asserted if the number of bytes in TX FIFO is equal or less than the TX FIFO threshold.
1	R/W	0	TXFIFOEMPTY TX FIFO Empty Interrupt. When enabled, this interrupt is asserted if the TX FIFO is emptied out.
0	R/W	0	TXFIFODONE TX FIFO Done Interrupt. When enabled, this interrupt is asserted after all bytes from TX FIFO were transferred to the Smart Card.

Note: This register provides information about the state of each interrupt bit. You can clear the register bits individually by writing '1' to a bit you intend to clear.

7.8.6.4. Smart Card Reader FIFO Control and Status Register(Default Value: 0x00000000)

Offset: 0x0C			Register Name: SCR_FCSR
Bit	R/W	Default/Hex	Description

31:11	/	/	/
10	R/W	0	RXFIFOFLUSH Flush RX FIFO. RX FIFO is flushed, when '1' is written to this bit.
9	R	0	RXFIFOFULL RX FIFO Full.
8	R	1	RXFIFOEMPTY RX FIFO Empty.
7:3	/	/	/
2	R/W	0	TXFIFOFLUSH Flush TX FIFO. TX FIFO is flushed, when '1' is written to this bit.
1	R	0	TXFIFOFULL TX FIFO Full.
0	R	1	TXFIFOEMPTY TX FIFO Empty.

7.8.6.5. Smart Card Reader FIFO Counter Register(Default Value: 0x00000000)

Offset: 0x10			Register Name: SCR_FIFOCNT
Bit	R/W	Default/Hex	Description
31:24	R/W	0	RXFTH RX FIFO Threshold These bits set the interrupt threshold of RX FIFO. The interrupt is asserted when the number of bytes it receives is equal to, or exceeds the threshold.
23:16	R/W	0	TXFTH TX FIFO Threshold These bits set the interrupt threshold of TX FIFO. The interrupt is asserted when the number of bytes in TX FIFO is equal to or less than the threshold.
15:8	R	0	RXFCNT RX FIFO Counter These bits provide the number of bytes stored in the RXFIFO.
7:0	R	0	TXFCNT TX FIFO Counter These bits provide the number of bytes stored in the TXFIFO.

7.8.6.6. Smart Card Reader Repeat Control Register(Default Value: 0x00000000)

Offset: 0x14			Register Name: SCR_REPEAT
Bit	R/W	Default/Hex	Description
31:8	/	/	/

7:4	R/W	0	<p>RXRPT RX Repeat</p> <p>This is a 4-bit register that specifies the number of attempts to request character re-transmission after wrong parity was detected. The re-transmission of the character is requested using the error signal during the guard time.</p>
3:0	R/W	0	<p>TXRPT TX Repeat</p> <p>This is a 4-bit register that specifies the number of attempts to re-transmit the character after the Smart Card signals the wrong parity during the guard time.</p>

7.8.6.7. Smart Card Reader Clock Divisor Register(Default Value: 0x00000000)

Offset: 0x18			Register Name: SCR_CLKDIV
Bit	R/W	Default/Hex	Description
31:16	R/W	0	<p>BAUDDIV Baud Clock Divisor. This 16-bit register defines the divisor value used to generate the Baud Clock impulses from the system clock.</p> $BAUD = \frac{f_{sysclk}}{2 * (BAUDDIV + 1)}$
15:0	R/W	0	<p>SCCDIV Smart Card Clock Divisor. This 16-bit register defines the divisor value used to generate the Smart Card Clock from the system clock.</p> $f_{sclk} = \frac{f_{sysclk}}{2 * (SCCDIV + 1)}$ <p>f_{sclk} is the frequency of Smart Card Clock Signal.</p> <p>f_{sysclk} is the frequency of APB Clock.</p>

7.8.6.8. Smart Card Reader Line Time Register(Default Value: 0x00000000)

Offset: 0x1C			Register Name: SCR_LTIM
Bit	R/W	Default/Hex	Description
31:24	/	/	/
23:16	R/W	0	<p>ATR ATR Start Limit. This 16-bit register defines the maximum time between the rising edge of the scrstn signal and the start of ATR response.</p>

			ATR Start Limit = $128 * ATR * T_{scclk}$.
15:8	R/W	0	<p>RST Reset Duration. This 16-bit register sets the duration of the Smart Card reset sequence. This value is same for the cold and warm reset.</p> <p>Cold/Warm Reset Duration = $128 * RST * T_{scclk}$.</p>
7:0	R/W	0	<p>ACT Activation/Deactivation Time. This 16-bit register sets the duration of each part of the activation and deactivation sequence.</p> <p>Activation/Deactivation Duration = $128 * ACT * T_{scclk}$.</p> $T_{scclk} = \frac{1}{f_{scclk}}$ <p>f_{scclk} is the Smart Card Clock Cycle.</p>

7.8.6.9. Smart Card Reader Character Time Register(Default Value: 0x00000000)

Offset: 0x20			Register Name: SCR_CTIM
Bit	R/W	Default/Hex	Description
31:16	R/W	0	<p>CHARLIMIT Character Limit. This 16-bit register sets the maximum time between the leading edges of two consecutive characters. The value is ETUs.</p>
15:8	/	/	/
7:0	R/W	0	<p>GUARDTIME Character Guard time. This 8-bit register sets a delay at the end of each character transmitted from the Smart Card Reader to the Smart Card. The value is in ETUs. The parity error is besides signaled during the guard time.</p>

7.8.6.10. Smart Card Reader Line Control Register(Default Value: 0x00000000)

Offset: 0x30			Register Name: SCR_PAD
Bit	R/W	Default/Hex	Description
31:8	/	/	/
7	R/W	0	<p>DSCVPPPP Direct Smart Card Vpp Pause/Prog. It provides direct access to SCVPPPP output.</p>
6	R/W	0	<p>DSCVPPEN Direct Smart Card Vpp Enable. It provides direct access to SCVPPEN output.</p>

5	R/W	0	AUTOADEAVPP Automatic Vpp Handling. When high, it enables automatic handling of DSVPPEN and DSVPPPP signals during activation and deactivation sequence.
4	R/W	0	DSCVCC Direct Smart Card VCC. When DIRACCPADS='1', the DSCVCC bit provides direct access to SCVCC pad.
3	R/W	0	DSCRST Direct Smart Card Clock. When DIRACCPADS='1', the DSCRST bit provides direct access to SCRST pad.
2	R/W	0	DSCCLK Direct Smart Card Clock. When DIRACCPADS='1', the DSCCLK bit provides direct access to SCCLK pad.
1	R/W	0	DSCIO Direct Smart Card Input/Output. When DIRACCPADS='1', the DSCIO bit provides direct access to SCIO pad.
0	R/W	0	DIRACCPADS Direct Access to Smart Card Pads. When high, it disables a serial interface functionality and enables direct control of the smart card pads using following 4 bits.

Note: This register provides direct access to smart card pads without serial interface assistance. You can use this register feature with synchronous and any other non-ISO 7816 and non-EMV cards.

7.8.6.11. Smart Card Reader FIFO Data Register(Default Value: 0x00000000)

Offset: 0x0100			Register Name: SCR_FIFO
Bit	R/W	Default/Hex	Description
31:8	/	/	/
7:0	R/W	0	FIFO_DATA This 8-bit register provides access to the RX and TX FIFO buffers. The TX FIFO is accessed during the APB write transfer. The RX FIFO is accessed during the APB read transfer.

7.9. EMAC

7.9.1. Overview

The Ethernet MAC(EMAC) controller enables a host to transmit and receive data over Ethernet in compliance with the IEEE 802.3-2002 standard. It supports 10M/100M/1000M external PHY with RMII/ RGMII interface in both full and half duplex mode. The Ethernet MAC-DMA is designed for packet-oriented data transfers based on a linked list of descriptors. 4K Byte TXFIFO and 16K Byte RXFIFO are provided to keep continuous transmission and reception. Flow Control, CRC Pad & Stripping, and address filtering are also supported in this module.

The Ethernet MAC Controller includes the following features:

- Supports 10/100/1000Mbps data transfer rates
- Supports RMII/RGMII PHY interface
- Supports both full-duplex and half-duplex operation
- Programmable frame length to support Standard or Jumbo Ethernet frames with sizes up to 16 KB
- Supports a variety of flexible address filtering modes
- Separate 32-bit status returned for transmission and reception packets
- Optimization for packet-oriented DMA transfers with frame delimiters
- Support linked-list (chained) descriptor chaining
- Descriptor architecture, allowing large blocks of data transfer with minimum CPU intervention; each descriptor can transfer up to 4 KB of data
- Comprehensive status reporting for normal operation and transfers with errors
- 4KB TXFIFO for transmission packets and 16KB RXFIFO for reception packets
- Programmable interrupt options for different operational conditions

7.9.2. Block Diagram

The EMAC Controller block diagram is shown below:

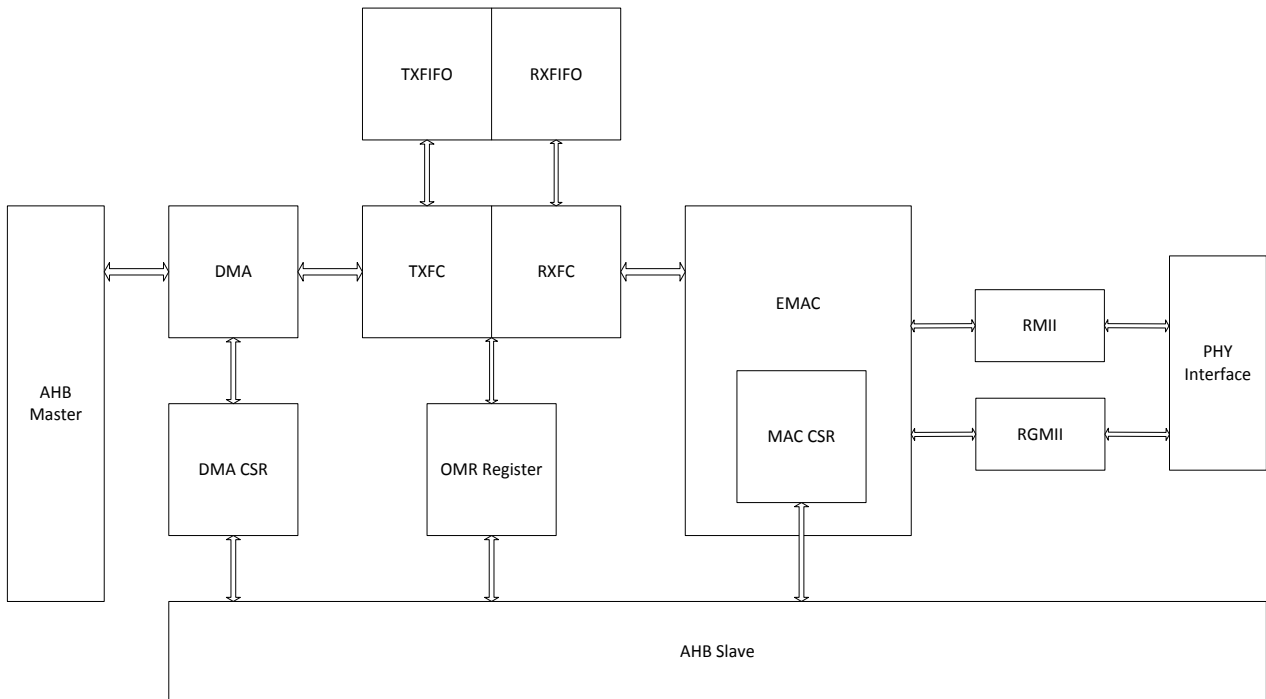

Figure 7-19. EMAC Block Diagram

7.9.3. EMAC Core Register List

Module Name	Base Address
EMAC	0x01C30000

Register Name	Offset	Description
BASIC_CTL_0	0x00	Basic Control 0 Register
BASIC_CTL_1	0x04	Basic Control 1 Register
INT_STA	0x08	Interrupt Status Register
INT_EN	0x0C	Interrupt Enable Register
TX_CTL_0	0x10	Transmit Control 0 Register
TX_CTL_1	0x14	Transmit Control 1 Register
TX_FLOW_CTL	0x1C	Transmit Flow Control Register
TX_DMA_DESC_LIST	0x20	Transmit Descriptor List Address Register
RX_CTL_0	0x24	Receive Control 0 Register
RX_CTL_1	0x28	Receive Control 1 Register
RX_DMA_DESC_LIST	0x34	Receive Descriptor List Address Register
RX_FRM_FLT	0x38	Receive Frame Filter Register

RX_HASH_0	0x40	Hash Table 0 Register
RX_HASH_1	0x44	Hash Table 1 Register
MII_CMD	0x48	Management Interface Command Register
MII_DATA	0x4C	Management Interface Data Register
ADDR_HIGH_0	0x50	MAC Address High Register 0
ADDR_LOW_0	0x54	MAC Address High Register 0
ADDR_HIGH_x	0x50+8*x	MAC Address High Register x(x:1~7)
ADDR_LOW_x	0x54+8*x	MAC Address Low Register x(x:1~7)
TX_DMA_STA	0xB0	Transmit DMA Status Register
TX_CUR_DESC	0xB4	Current Transmit Descriptor Register
TX_CUR_BUF	0xB8	Current Transmit Buffer Address Register
RX_DMA_STA	0xC0	Receive DMA Status Register
RX_CUR_DESC	0xC4	Current Receive Descriptor Register
RX_CUR_BUF	0xC8	Current Receive Buffer Address Register
RGMII_STA	0xD0	RGMII Status Register

7.9.4. EMAC Core Register Description

7.9.4.1. Basic Control 0 Register(Default Value: 0x00000000)

Offset: 0x00			Register Name: BASIC_CTL_0
Bit	R/W	Default/Hex	Description
31:4	/	/	/
3:2	R/W	0	SPEED 00: 1000Mbps 11: 100Mbps 10: 10Mbps 01: Reserved
1	R/W	0	LOOPBACK 0: Disable; 1: Enable;
0	R/W	0	DUPLEX 0: Half-duplex 1: Full-duplex

7.9.4.2. Basic Control 1 Register(Default Value: 0x08000000)

Offset: 0x04			Register Name: BASIC_CTL_1
Bit	R/W	Default/Hex	Description
31:30	/	/	/
29:24	R/W	8	BURST_LEN The burst length of RX and TX DMA transfer.
23:2	/	/	/
1	R/W	0	RX_TX_PRI 0: RX DMA and TX DMA have same priority 1: RX DMA has priority over TX DMA
0	R/W	0	SOFT_RST When this bit is set, soft reset all registers and logic. All clock inputs must be valid before soft rest. This bit is cleared internally when the reset operation is completed fully. Before write any register, this bit should read a 0.

7.9.4.3. Interrupt Status Register(Default Value: 0x00000000)

Offset: 0x08			Register Name: INT_STA
Bit	R/W	Default/Hex	Description
31:17	/	/	/
16	R	0	RGMIILINK_STA_INT When this bit is asserted, the link status of RGMII interface is changed.
15:14	/	/	/
13	R	0	RX_EARLY_INT When this bit asserted, the RX DMA had filled the first data buffer of the receive frame.
12	R	0	RX_OVERFLOW_INT When this bit is asserted, the RX FIFO had an overflow error.
11	R	0	RX_TIMEOUT_INT When this bit asserted, the length of receive frame is greater than 2048 bytes(10240 when JUMBO_FRM_EN is set)
10	R	0	RX_DMA_STOPPED_INT When this bit asserted, the RX DMA FSM is stopped.
9	R	0	RX_BUF_UA_INT When this asserted, the RX DMA can't acquire next RX descriptor and RX DMA FSM is suspended. The ownership of next RX descriptor should be changed to RX DMA. The RX DMA FSM will resume when write to DMA_RX_START bit or next receive frame is coming.
8	R	0	RX_INT When this bit is asserted, a frame reception is completed. The RX DMA

			FSM remains in the running state.
7:6	/	/	/
5	R	0	TX_EARLY_INT When this bit is asserted , the frame is transmitted to FIFO totally.
4	R	0	TX_UNDERFLOW_INT When this bit is asserted, the TX FIFO had an underflow error.
3	R	0	TX_TIMEOUT_INT When this bit is asserted, the transmitter had been excessively active.
2	R	0	TX_BUF_UA_INT When this asserted, the TX DMA can not acquire next TX descriptor and TX DMA FSM is suspended. The ownership of next TX descriptor should be changed to TX DMA. The TX DMA FSM will resume when write to DMA_TX_START bit.
1	R	0	TX_DMA_STOPPED_INT When this bit is asserted, the TX DMA FSM is stopped.
0	R	0	TX_INT When this bit is asserted, a frame transmission is completed.

7.9.4.4. Interrupt Enable Register(Default Value: 0x00000000)

Offset: 0x0C			Register Name: INT_EN
Bit	R/W	Default/Hex	Description
31:14	/	/	/
13	R/W	0	RX_EARLY_INT_EN 0: Disable early receive interrupt enable 1: Enable early receive interrupt enable
12	R/W	0	RX_OVERFLOW_INT_EN 0: Disable overflow interrupt 1: Enable overflow interrupt
11	R/W	0	RX_TIMEOUT_INT_EN 0: Disable receive timeout interrupt 1: Enable receive timeout interrupt
10	R/W	0	RX_DMA_STOPPED_INT_EN 0: Disable receive DMA FSM stopped interrupt 1: Enable receive DMA FSM stopped interrupt
9	R/W	0	RX_BUF_UA_INT_EN 0: Disable receive buffer unavailable interrupt 1: Enable receive buffer unavailable interrupt
8	R/W	0	RX_INT_EN 0: Disable receive interrupt 1: Enable receive interrupt
7:6			

5	R/W	0	TX_EARLY_INT_EN 0: Disable early transmit interrupt 1: Enable early transmit interrupt
4	R/W	0	TX_UNDERFLOW_INT_EN 0: Disable underflow interrupt 1: Enable underflow interrupt
3	R/W	0	TX_TIMEOUT_INT_EN 0: Disable transmit timeout interrupt 1: Enable transmit timeout interrupt
2	R/W	0	TX_BUF_UA_INT_EN 0: Disable transmit buffer available interrupt 1: Enable transmit buffer available interrupt
1	R/W	0	TX_DMA_STOPPED_INT_EN 0: Disable transmit DMA FSM stopped interrupt 1: Enable transmit DMA FSM stopped interrupt
0	R/W	0	TX_INT_EN 0: Disable transmit interrupt 1: Enable transmit interrupt

7.9.4.5. Transmit Control 0 Register(Default Value: 0x00000000)

Offset: 0x10			Register Name: TX_CTL_0
Bit	R/W	Default/Hex	Description
31	R/W	0	TX_EN Enable transmitter. 0: Disable transmitter after current transmission 1: Enable
30	R/W	0	TX_FRM_LEN_CTL 0: Allow to transmit frames no more than 2,048 bytes (10,240 if JUMBO_FRM_EN is set) and cut off any bytes after that 1: Allow to transmit frames of up to 16,384 bytes
29:0	/	/	/

7.9.4.6. Transmit Control 1 Register(Default Value: 0x00000000)

Offset: 0x14			Register Name: TX_CTL_1
Bit	R/W	Default/Hex	Description
31	R/W	0	TX_DMA_START When set this bit, the TX DMA FSM will go no to work. It is cleared internally and always read a 0.
30	R/W	0	TX_DMA_EN

			0: Stop TX DMA after the completion of current frame transmission. 1: Start and run TX DMA.
29:11	/	/	/
10:8	R/W	0	TX_TH The threshold value of TX DMA FIFO. When TX_MD is 0, transmission starts when the size of frame in TX DMA FIFO is greater than the threshold. In addition, full frames with a length less than the threshold are transferred automatically. 000: 64 001: 128 010: 192 011: 256 Others: Reserved
7:2	/	/	/
1	R/W	0	TX_MD 0: Transmission starts after the number of data in TX DAM FIFO is greater than TX_TH 1: Transmission starts after a full frame located in TX DMA FIFO
0	R/W	0	FLUSH_TX_FIFO The functionality that flush the data in the TX FIFO. 0: Enable 1: Disable

7.9.4.7. Transmit Flow Control Register(Default Value: 0x00000000)

Offset: 0x1C			Register Name: TX_FLOW_CTL
Bit	R/W	Default/Hex	Description
31	R/W	0	TX_FLOW_CTL_STA This bit indicates a pause frame transmission is in progress. When the configuration of flow control is ready, set this bit to transmit a pause frame in full-duplex mode or activate the backpressure function. After completion of transmission, this bit will be cleared automatically. Before write register TX_FLOW_CTRL, this bit must be read as 0.
30:22	/	/	/
21:20	R/W	0	TX_PAUSE_FRM_SLOT The threshold of the pause timer at which the input flow control signal is checked for automatic retransmission of pause frame. The threshold values should be always less than the PAUSE_TIME
19:4	R/W	0	PAUSE_TIME The pause time field in the transmitted control frame.
3:2	/	/	/
1	R/W	0	ZQP_FRM_EN

			When set, enable the functionality to generate Zero-Quanta Pause control frame.
0	R/W	0	<p>TX_FLOW_CTL_EN</p> <p>When set, enable flow control operation to transmit pause frames in full-duplex mode, or enable the back-pressure operation in half-duplex mode.</p> <p>0: Disable 1: Enable</p>

7.9.4.8. Transmit DMA Descriptor List Address Register(Default Value: 0x00000000)

Offset: 0x20			Register Name: TX_DMA_LIST
Bit	R/W	Default/Hex	Description
31:0	R/W	0	<p>TX_DESC_LIST</p> <p>The base address of transmit descriptor list. It must be 32-bit aligned.</p>

7.9.4.9. Receive Control 0 Register(Default Value: 0x00000000)

Offset: 0x24			Register Name: RX_CTL_0
Bit	R/W	Default/Hex	Description
31	R/W	0	<p>RX_EN</p> <p>Enable receiver</p> <p>0: Disable receiver after current reception 1: Enable</p>
30	R/W	0	<p>RX_FRM_LEN_CTL</p> <p>0: Allow to receive frames less than or equal to 2,048 bytes (10,240 if JUMBO_FRM_EN is set) and cuts off any bytes received after that 1: Allow to receive frames of up to 16,384 bytes</p>
29	R/W	0	<p>JUMBO_FRM_EN</p> <p>When set, allows Jumbo frames of 9,018 bytes without reporting a giant frame error in the receive frame status.</p>
28	R/W	0	<p>STRIP_FCS</p> <p>When set, strip the Pad/FCS field on received frames only when the length's field value is less than or equal to 1,500 bytes.</p>
27	R/W	0	<p>CHECK_CRC</p> <p>When set, calculate CRC and check the IPv4 Header Checksum.</p>
26:18	/	/	/
17	R/W	0	<p>RX_PAUSE_FRM_MD</p> <p>0: Only detect multicast pause frame specified in the 802.3x standard. 1: In addition to detect multicast pause frame specified in the 802.3x standard, also detect unicast pause frame with address specified in MAC</p>

			Address 0 High Register and MAC address 0 Low Register.
16	R/W	0	RX_FLOW_CTL_EN When set, enable the functionality that decode the received pause frame and disable its transmitter for a specified time by pause frame.
15:0	/	/	/

7.9.4.10. Receive Control 1 Register(Default Value: 0x00000000)

Offset: 0x28			Register Name: RX_CTL_1
Bit	R/W	Default/Hex	Description
31	R/W	0	RX_DMA_START When set, the RX DMA will go no to work. It is cleared internally and always read a 0.
30	R/W	0	RX_DMA_EN 0: Stop RX DMA after finish receiving current frame 1: Start and run RX DMA
29:25	/	/	/
24	R/W	0	RX_FIFO_FLOW_CTL 0: Disable RX flow control 1: Enable RX flow control based on RX_FLOW_CTL_TH_DEACT and RX_FLOW_CTL_TH_ACT
23:22	R/W	0	RX_FLOW_CTL_TH_DEACT The threshold for deactivating flow control in both half-duplex mode and full-duplex mode 00: Full minus 1 KB 01: Full minus 2 KB 10: Full minus 3 KB 11: Full minus 4 KB
21:20	R/W	0	RX_FLOW_CTL_TH_ACT The threshold for activating flow control in both half-duplex mode and full-duplex mode. 00: Full minus 1 KB 01: Full minus 2 KB 10: Full minus 3 KB 11: Full minus 4 KB
19:6	/	/	/
5:4	R/W	0	RX_TH The threshold value of RX DMA FIFO. When RX_MD is 0, RX DMA starts to transfer data when the size of received frame in RX DMA FIFO is greater than the threshold. In addition, full frames with a length less than the threshold are transferred automatically. 00: 64 01: 32

			10: 96 11: 128
3	R/W	0	RX_ERR_FRM 0: RX DMA drops frames with error 1: RX DMA forwards frames with error
2	R/W	0	RX_RUNT_FRM When set, forward undersized frames with no error and length less than 64bytes
1	R/W	0	RX_MD 0: RX DMA reads data from RX DMA FIFO to host memory after the number of data in RX DAM FIFO is greater than RX_TH 1: RX DMA reads data from RX DMA FIFO to host memory after a complete frame has been written to RX DMA FIFO
0	R/W	0	FLUSH_RX_FRM The functionality that flush the frames when receive descriptors/buffers is unavailable 0: Enable 1: Disable

7.9.4.11. Receive DMA Descriptor List Address Register(Default Value: 0x00000000)

Offset: 0x34			Register Name: RX_DMA_LIST
Bit	R/W	Default/Hex	Description
31:0	R/W	0	RX_DESC_LIST The base address of receive descriptor list. It must be 32-bit aligned.

7.9.4.12. Receive Frame Filter Register(Default Value: 0x00000000)

Offset: 0x38			Register Name: RX_FRM_FLT
Bit	R/W	Default/Hex	Description
31	R/W	0	DIS_ADDR_FILTER 0: Enable address filter 1: Disable address filter
30:18	/	/	/
17	R/W	0	DIS_BROADCAST 0: Receive all broadcast frames 1: Drop all broadcast frames
16	R/W	0	RX_ALL_MULTICAST 0: Filter multicast frame according to HASH_MULTICAST 1: Receive all multicast frames
15:14	/	/	

13:12	R/W	0	CTL_FRM_FILTER 00, 01: Drop all control frames 10: Receive all control frames 11: Receive all control frames when pass the address filter
11:10	/	/	/
9	R/W	0	HASH_MULTICAST 0: Filter multicast frames by comparing the DA field with the values in DA MAC address registers 1: Filter multicast frames according to the hash table
8	R/W	0	HASH_UNICAST 0: Filter unicast frames by comparing the DA field with the values in DA MAC address registers 1: Filter unicast frames according to the hash table
7	/	/	/
6	R/W	0	SA_FILTER_EN 0: Receive frames and update the result of SA filter 1: Update the result of SA filter. In addition, if the SA field of received frame does not match the values in SA MAC address registers, drop this frame.
5	R/W	0	SA_INV_FILTER 0: When the SA field of current frame matches the values in SA MAC address registers, it passes the SA filter 1: When the SA field of current frame does not match the values in SA MAC address registers,, it passes the SA filter
4	R/W	0	DA_INV_FILTER 0: Normal filtering of frames is performed 1: Filter both unicast and multicast frames by comparing DA field in inverse filtering mode
3:2	/	/	/
1	R/W	0	FLT_MD 0: If the HASH_MULTICAST or HASH_UNICAST is set, the frame is passed only when it matches the Hash filter 1: Receive the frame when it pass the address register filter or the hash filter(set by HASH_MULTICAST or HASH_UNICAST)
0	R/W	0	RX_ALL 0: Receive the frames that pass the SA/DA address filter 1: Receive all frames and update the result of address filter(pass or fail) in the receive status word

7.9.4.13. Receive Hash Table 0 Register(Default Value: 0x00000000)

Offset: 0x40			Register Name: RX_HASH_0
Bit	R/W	Default/Hex	Description

31:0	R/W	0	HASH_TAB_0 The upper 32 bits of Hash table for receive frame filter.
------	-----	---	---

7.9.4.14. Receive Hash Table 1 Register(Default Value: 0x00000000)

Offset: 0x44			Register Name: RX_HASH_1
Bit	R/W	Default/Hex	Description
31:0	R/W	0	HASH_TAB_1 The lower 32 bits of Hash table for receive frame filter.

7.9.4.15. MII Command Register(Default Value: 0x00000000)

Offset: 0x48			Register Name: MII_CMD
Bit	R/W	Default/Hex	Description
31:23	/	/	/
22:20	R/W	0	MDC_DIV_RATIO_M MDC clock divide ration(m). The source of MDC clock is AHB clock. 000: 16 001: 32 010: 64 011: 128 Others: Reserved
19:17	/	/	/
16:12	R/W	0	PHY_ADDR Select a PHY device from 32 possible candidates.
11:9	/	/	/
8:4	R/W	0	PHY_REG_ADDR Select register in the selected PHY device
3:2	/	/	/
1	R/W	0	MII_WR 0: Read register in selected PHY and return data in EMAC_GMII_DATA 1: Write register in selected PHY using data in EMAC_GMII_DATA
0	R/W	0	MII_BUSY This bit indicates that a read or write operation is in progress. When prepared the data and register address for a write operation or the register address for a read operation, set this bit and start to access register in PHY. When this bit is cleared automatically, the read or write operation is over and the data in EMAC_GMII_DATA is valid for a read operation.

7.9.4.16. MII Data Register(Default Value: 0x00000000)

Offset: 0x4C			Register Name: MII_DATA
Bit	R/W	Default/Hex	Description
31:16	/	/	/
15:0	R/W	0	MII_DATA The 16-bit data to be written to or read from the register in the selected PHY.

7.9.4.17. MAC Address 0 High Register(Default Value: 0x0000FFFF)

Offset: 0x50			Register Name: ADDR0_HIGH
Bit	R/W	Default/Hex	Description
31:16	/	/	/
15:0	R/W	0xFFFF	MAC_ADDR_0_HIGH The upper 16bits of the 1 st MAC address.

7.9.4.18. MAC Address 0 Low Register(Default Value: 0xFFFFFFFF)

Offset: 0x54			Register Name: ADDR0_LOW
Bit	R/W	Default/Hex	Description
31:0	R/W	0xFFFFFFFF	MAC_ADDR_0_LOW The lower 32bits of 1 st MAC address.

7.9.4.19. MAC Address x High Register(Default Value: 0x0000FFFF)

Offset: 0x50+8*x (x=1~7)			Register Name: ADDR _x _HIGH
Bit	R/W	Default/Hex	Description
31	R/W	0	MAC_ADDR_CTL 0: MAC address x(x: 1~7) is not valid, and it will be ignored by the address filter 1: MAC address x(x: 1~7) is valid
30	R/W	0.	MAC_ADDR_TYPE 1: MAC address x(x:1~7) used to compare with the source address of the received frame 0: MAC address x(x:1~7) used to compare with the destination address of the received frame
29:24	R/W	0	MAC_ADDR_BYTE_CTL MAC address byte control mask. The lower bit of mask controls the

			lower byte of in MAC address x(x:1~7). When the bit of mask is 1, do not compare the corresponding byte.
23:16	/	/	/
15:0	R/W	0xFFFF	MAC_ADDR_x_HIGH The upper 16bits of the MAC address x(x:1~7).

7.9.4.20. MAC Address x Low Register(Default Value: 0xFFFFFFFF)

Offset: 0x54+8*x (x=1~7)			Register Name: ADDRx_LOW
Bit	R/W	Default/Hex	Description
31:0	R/W	0xFFFFFFFF	MAC_ADDR_x_LOW The lower 32bits of MAC address x(x:1~7).

7.9.4.21. Transmit DMA Status Register(Default Value: 0x00000000)

Offset: 0xB0			Register Name: TX_DMA_STA
Bit	R/W	Default/Hex	Description
31:3	/	/	/
2:0	R	0	TX_DMA_STA The state of Transmit DMA FSM. 000: STOP: When reset or disable TX DMA; 001: RUN_FETCH_DESC: Fetching TX DMA descriptor; 010: RUN_WAIT_STA: Waiting for the status of TX frame; 011: RUN_TRANS_DATA: Passing frame from host memory to TX DMA FIFO; 111: RUN_CLOSE_DESC: Closing TX descriptor. 110: SUSPEND: TX descriptor unavailable or TX DMA FIFO underflow; 100, 101: Reserved;

7.9.4.22. Transmit DMA Current Descriptor Register(Default Value: 0x00000000)

Offset: 0xB4			Register Name: TX_DMA_CUR_DESC
Bit	R/W	Default/Hex	Description
31:0	R	0	The address of current transmit descriptor.

7.9.4.23. Transmit DMA Current Buffer Address Register(Default Value: 0x00000000)

Offset: 0xB8			Register Name: TX_DMA_CUR_BUF
--------------	--	--	--------------------------------------

Bit	R/W	Default/Hex	Description
31:0	R	0	The address of current transmit DMA buffer.

7.9.4.24. Receive DMA Status Register(Default Value: 0x00000000)

Offset: 0xC0			Register Name: RX_DMA_STA
Bit	R/W	Default/Hex	Description
31:3	/	/	/
2:0	R	0	RX_DMA_STA The state of RX DMA FSM. 000: STOP: When reset or disable RX DMA; 001: RUN_FETCH_DESC: Fetching RX DMA descriptor; 011: RUN_WAIT_FRM: Waiting for frame. 100: SUSPEND: RX descriptor unavailable; 101: RUN_CLOSE_DESC: Closing RX descriptor. 111: RUN_TRANS_DATA: Passing frame from host memory to RX DMA FIFO; 010, 110: Reserved.

7.9.4.25. Receive DMA Current Descriptor Register(Default Value: 0x00000000)

Offset: 0xC4			Register Name: RX_DMA_CUR_DESC
Bit	R/W	Default/Hex	Description
31:0	R	0	The address of current receive descriptor

7.9.4.26. Receive DMA Current Buffer Address Register(Default Value: 0x00000000)

Offset: 0xC8			Register Name: RX_DMA_CUR_BUF
Bit	R/W	Default/Hex	Description
31:0	R	0	The address of current receive DMA buffer

7.9.4.27. RGMII Status Register(Default Value: 0x00000000)

Offset: 0xD0			Register Name: RGMII_STA
Bit	R/W	Default/Hex	Description
31:4	/	/	/
3	R	0	RGMII_LINK The link status of RGMII interface

			0: down 1: up
2:1	R	0	RGMII_LINK_SPD The link speed of RGMII interface 00: 2.5 MHz 01: 25 MHz 10: 125 MHz
0	R	0	RGMII_LINK_MD The link Mode of RGMII interface 0: Half-Duplex 1: Full-Duplex

7.9.5. EMAC RX/TX Descriptor

The EMAC' internal DMA transfers data between host memory and internal RX/TX FIFO with a linked list of descriptors. Each descriptor is consisted of four words, and contains some necessary information to transfer TX and RX frames. The descriptor list structure is shown in [Figure 7-20](#). The address of each descriptor must be 32-bit aligned.

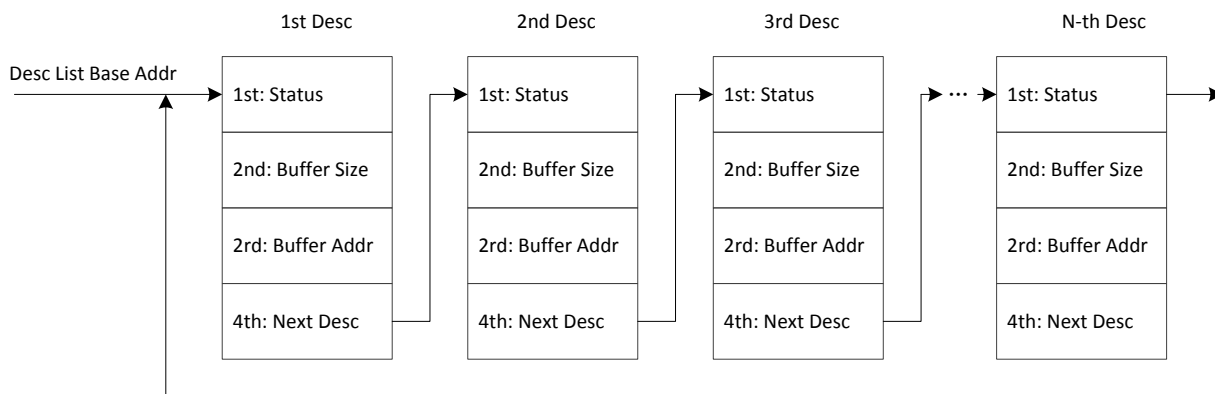

Figure 7-20. EMAC RX/TX Descriptor List

7.9.5.1. Transmit Descriptor

1st Word of Transmit Descriptor

Bits	Description
31	TX_DESC_CTL When set, current descriptor can be used by DMA. This bit is cleared by DMA when the whole frame is transmitted or all data in current descriptor's buffer are transmitted.
30:17	Reserved
16	TX_HEADER_ERR

	When set, the checksum of transmitted frame's header is wrong.
15	Reserved
14	TX_LENHT_ERR When set, the length of transmitted frame is wrong.
13	Reserved
12	TX_PAYLOAD_ERR When set, the checksum of transmitted frame's payload is wrong.
11	Reserved
10	TX_CRIS_ERR When set, carrier is lost during transmission.
9	TX_COL_ERR_0 When set, the frame is aborted because of collision after contention period.
8	TX_COL_ERR_1 When set, the frame is aborted because of too many collisions.
7	Reserved.
6:3	TX_COL_CNT The number of collisions before transmission.
2	TX_DEFER_ERR When set, the frame is aborted because of too much deferral.
1	TX_UNDERFLOW_ERR When set, the frame is aborted because of TX FIFO underflow error.
0	TX_DEFER When set in Half-Duplex mode, the EMAC defers the frame transmission.

2nd Word of Transmit Descriptor

Bits	Description
31	TX_INT_CTL When set and the current frame have been transmitted, the TX_INT in Interrupt Status Register will be set.
30	LAST_DESC When set, current descriptor is the last one for current frame.
29	FIR_DESC When set, current descriptor is the first one for current frame.
28:27	CHECKSUM_CTL These bits control to insert checksums in transmit frame.
26	CRC_CTL When set, CRC field is not transmitted.
25:11	Reserved
10:0	BUF_SIZE The size of buffer specified by current descriptor.

3rd Word of Transmit Descriptor

Bits	Description
31:0	BUF_ADDR The address of buffer specified by current descriptor.

4th Word of Transmit Descriptor

Bits	Description
31:0	NEXT_DESC_ADDR The address of next descriptor. It must be 32-bit aligned.

7.9.5.2. Receive Descriptor

1st Word of Receive Descriptor

Bits	Description
31	RX_DESC_CTL When set, current descriptor can be used by DMA. This bit is cleared by DMA when complete frame is received or current descriptor's buffer is full.
30	RX_DAF_FAIL When set, current frame don't pass DA filter.
29:16	RX_FRM_LEN When LAST_DESC is not set and no error bit is set, this field is the length of received data for current frame. When LAST_DESC is set, RX_OVERFLOW_ERR and RX_NO_ENOUGH_BUF_ERR are not set, this field is the length of receive frame.
15	Reserved
14	RX_NO_ENOUGH_BUF_ERR When set, current frame is clipped because of no enough buffer.
13	RX_SAF_FAIL When set, current fame don't pass SA filter.
12	Reserved.
11	RX_OVERFLOW_ERR When set, a buffer overflow error occurred and current frame is wrong.
10	Reserved
9	FIR_DESC When set, current descriptor is the first descriptor for current frame.
8	LAST_DESC When set, current descriptor is the last descriptor for current frame.
7	RX_HEADER_ERR When set, the checksum of frame's header is wrong.

6	RX_COL_ERR When set, there is a late collision during reception in half-duplex mode.
5	Reserved.
4	RX_LENGTH_ERR When set, the length of current frame is wrong.
3	RX_PHY_ERR When set, the receive error signal from PHY is asserted during reception.
2	Reserved.
1	RX_CRC_ERR When set, the CRC field of received frame is wrong.
0	RX_PAYLOAD_ERR When set, the checksum or length of received frame's payload is wrong.

2nd Word of Receive Descriptor

Bits	Description
31	RX_INT_CTL When set and a frame have been received, the RX_INT will not be set.
30:11	Reserved
10:0	BUF_SIZE The size of buffer specified by current descriptor.

3rd Word of Receive Descriptor

Bits	Description
31:0	BUF_ADDR The address of buffer specified by current descriptor.

4th Word of Receive Descriptor

Bits	Description
31:0	NEXT_DESC_ADDR The address of next descriptor. This field must be 32-bit aligned.

7.10. TSC

7.10.1. Overview

The transport stream controller(TSC) is responsible for de-multiplexing and pre-processing the inputting multimedia data defined in ISO/IEC 13818-1.

The transport stream controller receives multimedia data stream from SSI (Synchronous Serial Port)/SPI (Synchronous Parallel Port) inputs and de-multiplexing the data into Packets by PID (Packet Identify). Before the Packet to be store to memory by DMA, it can be pre-processing by the Transport Stream Descrambler.

The transport stream controller can be used for almost all multi-media application cases, example: DVB Set top Box, IPTV, Streaming-media Box, multi-media players and so on.

The Transport Stream Controller (TSC) includes the following features:

- Supports industry-standard AMBA Host Bus (AHB) and it is fully compliant with the AMBA Specification, Revision 2.0. Supports 32-bit Little Endian bus.
- Supports AHB 32-bit bus width
- One external Synchronous Parallel Interface (SPI) or one external Synchronous Serial Interface (SSI)
- 32 channels PID filter
- Multiple transport stream packet (188, 192, 204) format support
- SPI and SSI timing parameters are configurable
- Hardware packet synchronous byte error detecting
- Hardware PCR packet detecting
- Configurable SPI transport stream generator for streams in DRAM memory
- DMA is supported for transferring data
- Interrupt is supported
- Support DVB-CSA V1.1 Descrambler

The Top Diagram of TSC is below:

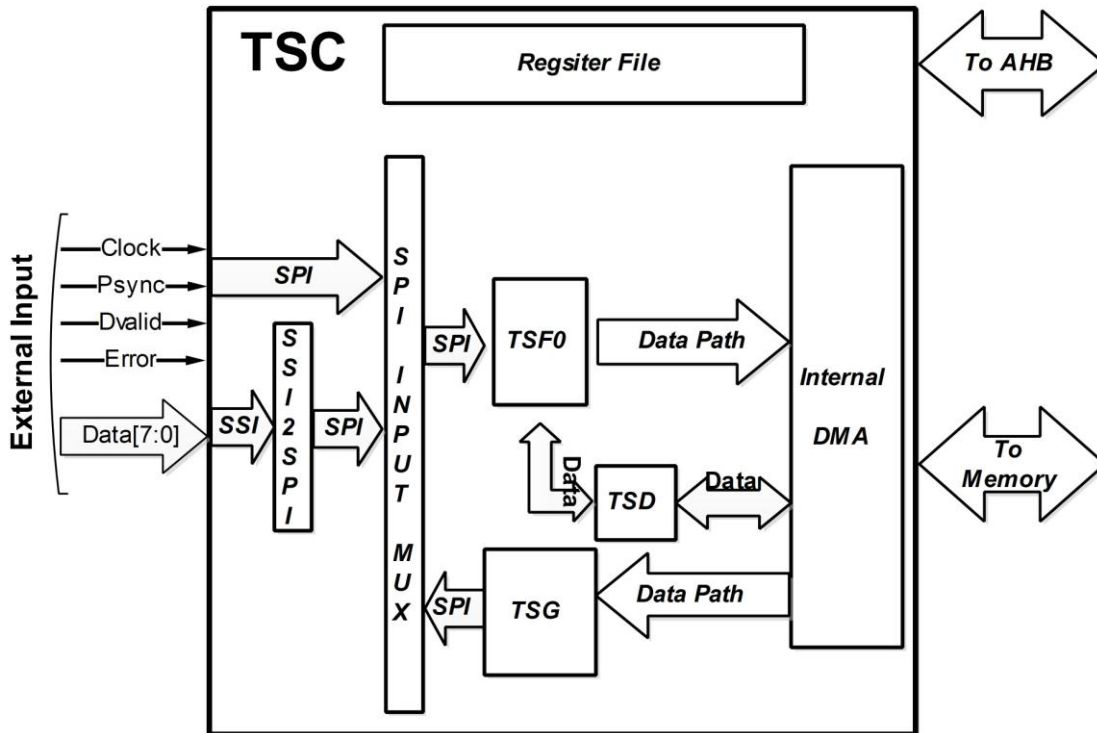

Figure 7-21. TSC Block Diagram

Note:

- TSC – TS Controller
- TSF – TS Filter
- TSD – TS Descrambler
- TSG – TS Generator

7.10.2. Transport Stream Input Timing Diagram

Table 7-1. Input Signals Description

Name	Description
Clock	Clock of SPI/SSI data input
Psync	Packet sync (or Start flag) for TS packet
Dvalid	Data valid flag for TS data input
Error	Error flag for TS data, but do not used by TSC
Data[7:0]	TS data input. Data[7:0] are used in SPI mode; Only Data[0] is used in SSI mode.

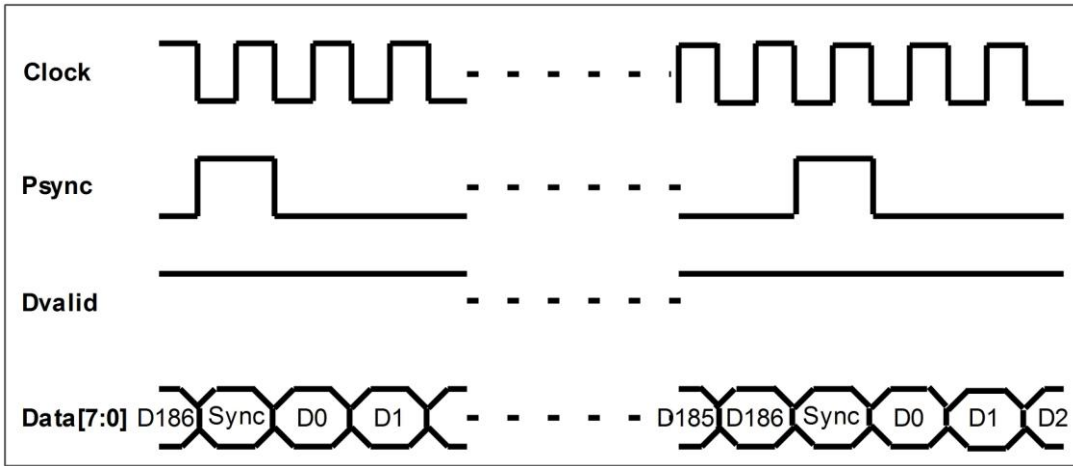

Figure 7-22. Input Timing for SPI mode

(CLOCK = Rising Edge, PSYNC = High Active, DVALID = High Active, Packet Size = 188 Bytes)

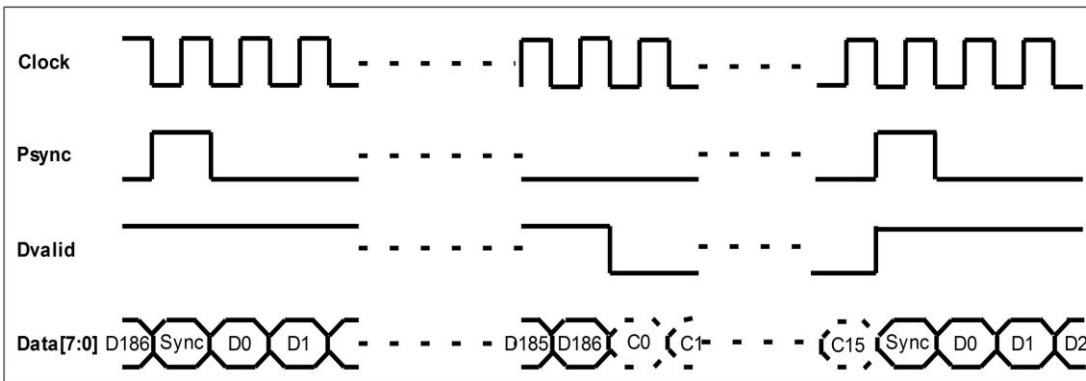

Figure 7-23. Alternative Input Timing for SPI mode

(CLOCK = Rising Edge, PSYNC = High Active, DVALID = High Active, Packet Size = 188 Bytes)

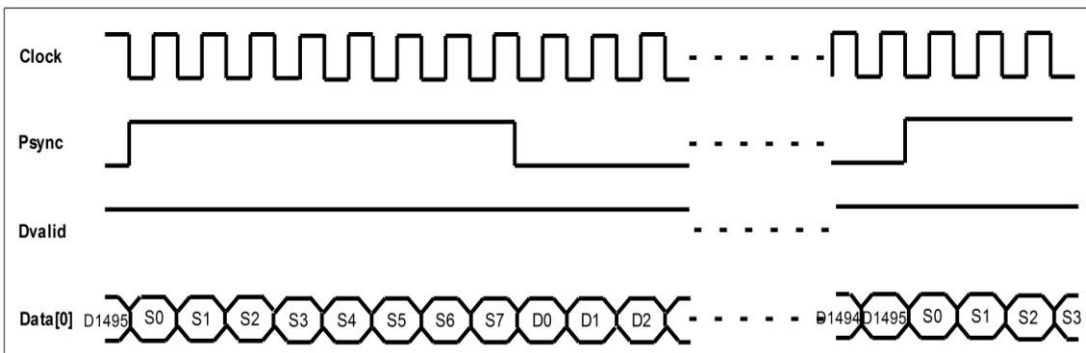

Figure 7-24. Alternative Input Timing for SSI mode

(CLOCK = Rising Edge, PSYNC = High Active, DVALID = High Active, Packet Size = 188 Bytes)

7.10.3. Transport Stream Controller Register List

Module Name	Base Address
TSC	0x01C06000
TSG OFFSET	0x00000040
TSFO OFFSET	0x00000080
TSD OFFSET	0x00000180

Register Name	Offset	Description
TSC_CTLR	TSC + 0x00	TSC Control Register
TSC_STAR	TSC + 0x04	TSC Status Register
TSC_PCTLR	TSC + 0x10	TSC Port Control Register
TSC_PPARR	TSC + 0x14	TSC Port Parameter Register
TSC_TSFMUXR	TSC + 0x20	TSC TSF Input Multiplex Control Register
TSC_OUTMUXR	TSC + 0x28	TSC Port Output Multiplex Control Register
TSG_CTLR	TSG + 0x00	TSG Control Register
TSG_PPR	TSG + 0x04	TSG Packet Parameter Register
TSG_STAR	TSG + 0x08	TSG Status Register
TSG_CCR	TSG + 0x0c	TSG Clock Control Register
TSG_BBAR	TSG + 0x10	TSG Buffer Base Address Register
TSG_BSZR	TSG + 0x14	TSG Buffer Size Register
TSG_BPR	TSG + 0x18	TSG Buffer Pointer Register
TSF_CTLR	TSF + 0x00	TSF Control Register
TSF_PPR	TSF + 0x04	TSF Packet Parameter Register
TSF_STAR	TSF + 0x08	TSF Status Register
TSF_DIER	TSF + 0x10	TSF DMA Interrupt Enable Register
TSF_OIER	TSF + 0x14	TSF Overlap Interrupt Enable Register
TSF_DISR	TSF + 0x18	TSF DMA Interrupt Status Register
TSF_OISR	TSF + 0x1c	TSF Overlap Interrupt Status Register
TSF_PCRCR	TSF + 0x20	TSF PCR Control Register
TSF_PCRDR	TSF + 0x24	TSF PCR Data Register
TSF_CENR	TSF + 0x30	TSF Channel Enable Register
TSF_CPER	TSF + 0x34	TSF Channel PES Enable Register
TSF_CDER	TSF + 0x38	TSF Channel Descramble Enable Register
TSF_CINDR	TSF + 0x3c	TSF Channel Index Register
TSF_CCTLR	TSF + 0x40	TSF Channel Control Register
TSF_CSTAR	TSF + 0x44	TSF Channel Status Register
TSF_CCWIR	TSF + 0x48	TSF Channel CW Index Register
TSF_CPIDR	TSF + 0x4c	TSF Channel PID Register
TSF_CBBAR	TSF + 0x50	TSF Channel Buffer Base Address Register

TSF_CBSZR	TSF + 0x54	TSF Channel Buffer Size Register
TSF_CBWPR	TSF + 0x58	TSF Channel Buffer Write Pointer Register
TSF_CBRPR	TSF + 0x5c	TSF Channel Buffer Read Pointer Register
TSD_CTLR	TSD + 0x00	TSD Control Register
TSD_STAR	TSD + 0x04	TSD Status Register
TSD_CWIR	TSD + 0x1c	TSD Control Word Index Register
TSD_CWR	TSD + 0x20	TSD Control Word Register

7.10.4. Transport Stream Controller Register Description

7.10.4.1. TSC Control Register(Default Value: 0x00000000)

Offset: 0x00			Register Name: TSC_CTLR
Bit	R/W	Default/Hex	Description
31:0	/	/	/

7.10.4.2. TSC Status Register(Default Value: 0x00000000)

Offset: 0x04			Register Name: TSC_STAR
Bit	R/W	Default/Hex	Description
31:0	/	/	/

7.10.4.3. TSC Port Control Register(Default Value: 0x00000000)

Offset: 0x10			Register Name: TSC_PCTLR
Bit	R/W	Default/Hex	Description
31:1	/	/	/
0	R/W	0	TSInPort0Ctrl TS Input Port0 Control 0 – SPI 1 – SSI

7.10.4.4. TSC Port Parameter Register(Default Value: 0x00000000)

Offset: 0x14			Register Name: TSC_PPARR
Bit	R/W	Default/Hex	Description

31:8	/	/	/														
			<p>TSInPort0Par</p> <p>TS Input Port0 Parameters</p> <table border="1"> <thead> <tr> <th>Bit</th> <th>Definition</th> </tr> </thead> <tbody> <tr> <td>7:5</td> <td>Reserved</td> </tr> <tr> <td>4</td> <td>SSI data order 0: MSB first for one byte data 1: LSB first for one byte data</td> </tr> <tr> <td>3</td> <td>CLOCK signal polarity 0 : Rise edge capturing 1: Fall edge capturing</td> </tr> <tr> <td>2</td> <td>ERROR signal polarity 0: High level active 1: Low level active</td> </tr> <tr> <td>1</td> <td>DVALID signal polarity 0: High level active 1: Low level active</td> </tr> <tr> <td>0</td> <td>PSYNC signal polarity 0: High level active 1: Low level active</td> </tr> </tbody> </table>	Bit	Definition	7:5	Reserved	4	SSI data order 0: MSB first for one byte data 1: LSB first for one byte data	3	CLOCK signal polarity 0 : Rise edge capturing 1: Fall edge capturing	2	ERROR signal polarity 0: High level active 1: Low level active	1	DVALID signal polarity 0: High level active 1: Low level active	0	PSYNC signal polarity 0: High level active 1: Low level active
Bit	Definition																
7:5	Reserved																
4	SSI data order 0: MSB first for one byte data 1: LSB first for one byte data																
3	CLOCK signal polarity 0 : Rise edge capturing 1: Fall edge capturing																
2	ERROR signal polarity 0: High level active 1: Low level active																
1	DVALID signal polarity 0: High level active 1: Low level active																
0	PSYNC signal polarity 0: High level active 1: Low level active																
7:0	R/W	0x00															

7.10.4.5. TSC TSF Input Multiplex Control Register(Default Value: 0x00000000)

Offset: 0x20			Register Name: TSC_TSFMUXR
Bit	R/W	Default/Hex	Description
31:4	/	/	/
3:0	R/W	0x0	<p>TSF0InputMuxCtrl</p> <p>TSF0 Input Multiplex Control</p> <p>0x0 –Data from TSG</p> <p>0x1 –Data from TS IN Port0</p> <p>Others – Reserved</p>

7.10.4.6. TSC Port Output Multiplex Control Register(Default Value: 0x00000000)

Offset: 0x28			Register Name: TSC_TSFMUXR
Bit	R/W	Default/Hex	Description
31:0	/	/	/

7.10.4.7. TSC Port Output Multiplex Control Register(Default Value: 0x00000000)

Offset: TSG+0x00			Register Name: TSC_TSFMUXR
Bit	R/W	Default/Hex	Description
31:26	/	/	/
25:24	R	0	<p>TSGSts Status for TS Generator 0: IDLE state 1: Running state 2: PAUSE state Others: Reserved</p>
23:10	/	/	/
9	R/W	0	<p>TSGLBufMode Loop Buffer Mode When set to '1', the TSG external buffer is in loop mode.</p>
8	R/W	0	<p>TSGSyncByteChkEn Sync Byte Check Enable Enable/ Disable check SYNC byte fro receiving new packet 0: Disable 1: Enable If enable check SYNC byte and an error SYNC byte is receiver, TS Generator would come into PAUSE state. If the correspond interrupt is enable, the interrupt would happen.</p>
7:3	/	/	/
2	R/W	0	<p>TSGPauseBit Pause Bit for TS Generator Write '1' to pause TS Generator. TS Generator would stop fetch new data from DRAM. After finishing this operation, this bit will clear to zero by hardware. In PAUSE state, write '1' to resume this state.</p>
1	R/W	0	<p>TSGStopBit Stop Bit for TS Generator Write '1' to stop TS Generator. TS Generator would stop fetch new data from DRAM. The data already in its FIFO should be sent to TS filter. After finishing this operation, this bit will clear to zero by hardware.</p>
0	R/W	0	<p>TSGStartBit Start Bit for TS Generator Write '1' to start TS Generator. TS Generator would fetch data from DRAM and generate SPI stream to TS filter. This bit will clear to zero by hardware after TS Generator is running.</p>

7.10.4.8. TSG Packet Parameter Register(Default Value: 0x00470000)

Offset: TSG+0x04			Register Name: TSG_PPR
Bit	R/W	Default/Hex	Description
31:24	/	/	/
23:16	R/W	0x47	SyncByteVal Sync Byte Value This is the value of sync byte used in the TS Packet.
15:8	/	/	/
7	R/W	0	SyncBytePos Sync Byte Position 0: the 1st byte position 1: the 5th byte position Notes: This bit is only used for 192 bytes packet size.
6:2	/	/	/
1:0	R/W	0	PktSize Packet Size Byte Size for one TS packet 0: 188 bytes Others: Reserved

7.10.4.9. TSG Interrupt Enable and Status Register(Default Value: 0x00000000)

Offset: TSG+0x08			Register Name: TSG_IESR
Bit	R/W	Default/Hex	Description
31:20	/	/	/
19	R/W	0	TSGEndIE TS Generator (TSG) End Interrupt Enable 0: Disable 1: Enable If set this bit, the interrupt would assert to CPU when all data in external DRAM are sent to TS PID filter.
18	R/W	0	TSGFFIE TS Generator (TSG) Full Finish Interrupt Enable 0: Disable 1: Enable
17	R/W	0	TSGHFIE TS Generator (TSG) Half Finish Interrupt Enable 0: Disable 1: Enable
16	R/W	0	TSGErrSyncByteIE TS Generator (TSG) Error Sync Byte Interrupt Enable

			0: Disable 1: Enable
15:4	/	/	/
3	R/W	0	TSGEndSts TS Generator (TSG) End Status Write '1' to clear.
2	R/W	0	TSGFFSts TS Generator (TSG) Full Finish Status Write '1' to clear.
1	R/W	0	TSGHFSts TS Generator (TSG) Half Finish Status Write '1' to clear.
0	R/W	0	TSGErrSyncByteSts TS Generator (TSG) Error Sync Byte Status Write '1' to clear.

7.10.4.10. TSG Clock Control Register(Default Value: 0x00000000)

Offset: TSG+0x0C			Register Name: TSG_CCR
Bit	R/W	Default/Hex	Description
31:16	R/W	0x0	TSGCDF_N TSG Clock Divide Factor (N) The Numerator part of TSG Clock Divisor Factor.
15:0	R/W	0x0	TSGCDF_D TSG Clock Divide Factor (D) The Denominator part of TSG Clock Divisor Factor. Frequency of output clock: $F_o = (F_i * (N+1)) / (8 * (D+1))$. F_i is the input special clock of TSC, and D must not less than N.

7.10.4.11. TSG Buffer Base Address Register(Default Value: 0x00000000)

Offset: TSG+0x10			Register Name: TSG_BBAR
Bit	R/W	Default/Hex	Description
31:28	/	/	/
27:0	RW	0x0	TSGBufBase Buffer Base Address This value is a start address of TSG buffer. Note: This value should be 4-word (16Bytes) align, and the lowest 4-bit of this value should be zero.

7.10.4.12. TSG Buffer Size Register(Default Value: 0x00000000)

Offset: TSG+0x14			Register Name: TSG_BSZR
Bit	R/W	Default/Hex	Description
31:24	/	/	/
23:0	R/W	0	TSGBufSize Data Buffer Size for TS Generator It is in byte unit. The size should be 4-word (16Bytes) align, and the lowest 4 bits should be zero.

7.10.4.13. TSG Buffer Point Register(Default Value: 0x00000000)

Offset: TSG+0x18			Register Name: TSG_BPR
Bit	R/W	Default/Hex	Description
31:24	/	/	/
23:0	R	0	TSGBufPtr Data Buffer Pointer for TS Generator Current TS generator data buffer read pointer (in byte unit)

7.10.4.14. TSF Control and Status Register(Default Value: 0x00000000)

Offset: TSF+0x00			Register Name: TSF_CSR
Bit	R/W	Default/Hex	Description
31:3	/	/	/
2	R/W	0	TSF Enable 0: Disable TSF Input 1: Enable TSF Input
1	/	/	/
0			TSFGSR TSF Global Soft Reset A software writing '1' will reset all status and state machine of TSF. And it's cleared by hardware after finish reset. A software writing '0' has no effect.

7.10.4.15. TSF Packet Parameter Register(Default Value: 0x00470000)

Offset: TSF+0x04			Register Name: TSF_PPR
Bit	R/W	Default/Hex	Description

31:28	R/W	0	<p>LostSyncThd Lost Sync Packet Threshold It is used for packet sync lost by checking the value of sync byte.</p>
27:24	R/W	0	<p>SyncThd Sync Packet Threshold It is used for packet sync by checking the value of sync byte.</p>
23:16	R/W	0x47	<p>SyncByteVal Sync Byte Value This is the value of sync byte used in the TS Packet.</p>
15:10	/	/	/
9:8	R/W	0	<p>SyncMthd Packet Sync Method 0: By PSYNC signal 1: By sync byte 2: By both PSYNC and Sync Byte 3: Reserved</p>
7	R/W	0	<p>SyncBytePos Sync Byte Position 0: the 1st byte position 1: the 5th byte position Notes: This bit is only used for 192 bytes packet size.</p>
6:2	/	/	/
1:0	R/W	0	<p>PktSize Packet Size Byte Size for one TS packet 0: 188 bytes 1: 192 bytes 2: 204 bytes 3: Reserved</p>

7.10.4.16. TSF Interrupt Enable and Status Register(Default Value: 0x00000000)

Offset: TSF+0x08			Register Name: TSF_IESR
Bit	R/W	Default/Hex	Description
31:20	/	/	/
19	R/W	0	<p>TSFFOIE TS PID Filter (TSF) Internal FIFO Overrun Interrupt Enable 0: Disable 1: Enable</p>
18	R/W	0	<p>TSFPPDIE TS PCR Packet Detect Interrupt Enable 0: Disable 1: Enable</p>

17	R/W	0	TSFCOIE TS PID Filter (TSF) Channel Overlap Interrupt Global Enable 0: Disable 1: Enable
16	R/W	0	TSFCDIE TS PID Filter (TSF) Channel DMA Interrupt Global Enable 0: Disable 1: Enable
15:4	/	/	/
3	R/W	0	TSFFOIS TS PID Filter (TSF) Internal FIFO Overrun Status Write '1' to clear.
2	R/W	0	TSFPPDIS TS PCR Packet Found Status When it is '1', one TS PCR Packet is found. Write '1' to clear.
1	R	0	TSFCOIS TS PID Filter (TSF) Channel Overlap Status It is global status for 16 channel. It would clear to zero after all channels status bits are clear.
0	R	0	TSFCDIS TS PID Filter (TSF) Channel DMA status It is global status for 16 channel. It would clear to zero after all channels status bits are clear.

7.10.4.17. TSF DMA Interrupt Enable Register(Default Value: 0x00000000)

Offset: TSF+0x10			Register Name: TSF_DIER
Bit	R/W	Default/Hex	Description
31:0	R/W	0x0	DMAIE DMA Interrupt Enable DMA interrupt enable bits for channel 0~31.

7.10.4.18. TSF Overlap Interrupt Enable Register(Default Value: 0x00000000)

Offset: TSF+0x14			Register Name: TSF_OIER
Bit	R/W	Default/Hex	Description
31:0	R/W	0x0	OLPIE Overlap Interrupt Enable Overlap interrupt enable bits for channel 0~31.

7.10.4.19. TSF DMA Interrupt Status Register(Default Value: 0x00000000)

Offset: TSF+0x18			Register Name: TSF_DISR
Bit	R/W	Default/Hex	Description
31:0	R/W	0x0	<p>DMAIS</p> <p>DMA Interrupt Status</p> <p>DMA interrupt Status bits for channel 0~31.</p> <p>Set by hardware, and can be cleared by software writing '1'.</p> <p>When both these bits and the corresponding DMA Interrupt Enable bits set, the TSF interrupt will generate.</p>

7.10.4.20. TSF Overlap Interrupt Status Register(Default Value: 0x00000000)

Offset: TSF+0x1C			Register Name: TSF_OISR
Bit	R/W	Default/Hex	Description
31:0	R/W	0x0	<p>OLPIS</p> <p>Overlap Interrupt Status</p> <p>Overlap interrupt Status bits for channel 0~31.</p> <p>Set by hardware, and can be cleared by software writing '1'.</p> <p>When both these bits and the corresponding Overlap Interrupt Enable bits set, the TSF interrupt will generate.</p>

7.10.4.21. TSF PCR Control Register(Default Value: 0x00000000)

Offset: TSF+0x20			Register Name: TSF_PCRCR
Bit	R/W	Default/Hex	Description
31:17	/	/	/
16	R/W	0	<p>PCRDE</p> <p>PCR Detecting Enable</p> <p>0: Disable</p> <p>1: Enable</p>
15:13	/	/	/
12:8	R/W	0	<p>PCRCIND</p> <p>Channel Index m for Detecting PCR packet (m from 0 to 31)</p>
7:1	/	/	/
0	R	0	<p>PCRLSB</p> <p>PCR Contest LSB 1 bit</p> <p>PCR[0]</p>

7.10.4.22. TSF PCR Data Register(Default Value: 0x00000000)

Offset: TSF+0x24			Register Name: TSF_PCRDR
Bit	R/W	Default/Hex	Description
31:0	R	0	PCRMSB PCR Data High 32 bits PCR[33:1]

7.10.4.23. TSF Channel Enable Register(Default Value: 0x00000000)

Offset: TSF+0x30			Register Name: TSF_CENR
Bit	R/W	Default/Hex	Description
31:0	R/W	0	FilterEn Filter Enable for Channel 0~31 0: Disable 1: Enable From Disable to Enable, internal status of the corresponding filter channel will be reset.

7.10.4.24. TSF PES Enable Register(Default Value: 0x00000000)

Offset: TSF+0x34			Register Name: TSF_CPER
Bit	R/W	Default/Hex	Description
31:0	R/W	0x0	PESEn PES Packet Enable for Channel 0~31 0: Disable 1: Enable These bits should not be changed during the corresponding channel enable.

7.10.4.25. TSF Channel Descramble Enable Register(Default Value: 0x00000000)

Offset: TSF+0x38			Register Name: TSF_CDERR
Bit	R/W	Default/Hex	Description
31:0	R/W	0x0	DescEn Descramble Enable for Channel 0~31 0: Disable 1: Enable These bits should not be changed during the corresponding channel

			enable.
--	--	--	---------

7.10.4.26. TSF Channel Index Register(Default Value: 0x00000000)

Offset: TSF+0x3C			Register Name: TSF_CINDR
Bit	R/W	Default/Hex	Description
31:5	/	/	/
4:0	R/W	0x0	<p>CHIND Channel Index This value is the channel index for channel private registers access. Range is from 0x00 to 0x1f. Address range of channel private registers is 0x40~0x7f.</p>

7.10.4.27. TSF Channel Control Register(Default Value: 0x00000000)

Offset: TSF+0x40			Register Name: TSF_CCTLR
Bit	R/W	Default/Hex	Description
31:0	/	/	/

7.10.4.28. TSF Channel Status Register(Default Value: 0x00000000)

Offset: TSF+0x44			Register Name: TSF_CSTAR
Bit	R/W	Default/Hex	Description
31:0	/	/	/

7.10.4.29. TSF Channel CW Index Register(Default Value: 0x00000000)

Offset: TSF+0x48			Register Name: TSF_CCWIR
Bit	R/W	Default/Hex	Description
31:3	/	/	/
2:0	R/W	0x0	<p>CWIND Related Control Word Index Index to the control word used by this channel when Descramble Enable of this channel enable. This value is useless when the corresponding Descramble Enable is '0'.</p>

7.10.4.30. TSF Channel PID Register(Default Value: 0x1FFF0000)

Offset: TSF+0x4C			Register Name: TSF_CPIDR
Bit	R/W	Default/Hex	Description
31:16	R/W	0x1fff	PIDMSK Filter PID Mask for Channel
15:0	R/W	0x0	PIDVAL Filter PID value for Channel

7.10.4.31. TSF Channel Buffer Base Address Register(Default Value: 0x00000000)

Offset: TSF+0x50			Register Name: TSF_CBBAR
Bit	R/W	Default/Hex	Description
31:28	/	/	/
27:0	R/W	0	TSFBufBAddr Data Buffer Base Address for Channel It is 4-word (16Bytes) align address. The LSB four bits should be zero.

7.10.4.32. TSF Channel Buffer Size Register(Default Value: 0x00000000)

Offset: TSF+0x54			Register Name: TSF_CBSZR
Bit	R/W	Default/Hex	Description
31:26	/	/	/
25:24	R/W	0	CHDMAIntThd DMA Interrupt Threshold for Channel The unit is TS packet size. When received packet (has also stored in DRAM) size is beyond (>=) threshold value, the corresponding channel interrupt is generated to CPU. TSC should count the new received packet again, when exceed the specified threshold value, one new interrupt is generated again. 0: 1/2 data buffer packet size 1: 1/4 data buffer packet size 2: 1/8 data buffer packet size 3: 1/16 data buffer packet size
23:21	/	/	/
20:0	R/W	0	CHBufPktSz Data Buffer Packet Size for Channel The exact buffer size of buffer is N+1 bytes. The maximum buffer size is 2MB. This size should be 4-word (16Bytes) aligned. The LSB four bits should be zero.

7.10.4.33. TSF Channel Write Pointer Register(Default Value: 0x00000000)

Offset: TSF+0x58			Register Name: TSF_CBWPR
Bit	R/W	Default/Hex	Description
31:21	/	/	/
20:0	R/W	0	BufWrPtr Data Buffer Write Pointer (in Bytes) This value is changed by hardware, when data is filled into buffer, this pointer is increased. And this pointer can be set by software, but it should not be changed by software during the corresponding channel is enable.

7.10.4.34. TSF Channel Read Pointer Register(Default Value: 0x00000000)

Offset: TSF+0x5C			Register Name: TSF_CBRPR
Bit	R/W	Default/Hex	Description
31:21	/	/	/
20:0	R/W	0	BufRdPtr Data Buffer Read Pointer (in Bytes) This pointer should be changed by software after the data of buffer is read.

7.10.4.35. TSD Control Register(Default Value: 0x00000000)

Offset: TSD+0x00			Register Name: TSD_CTLR
Bit	R/W	Default/Hex	Description
31:2	/	/	/
1:0	R/W	0x0	DescArith Descramble Arithmetic 00: DVB CSA V1.1 Others: Reserved

7.10.4.36. TSD Status Register(Default Value: 0x00000000)

Offset: TSD+0x04			Register Name: TSD_STAR
Bit	R/W	Default/Hex	Description
31:0	/	/	/

7.10.4.37. TSD Control Word Index Register(Default Value: 0x00000000)

Offset: TSD+0x1C			Register Name: TSD_CWIR
Bit	R/W	Default/Hex	Description
31:3	/	/	/
6:4	R/W	0x0	<p>CWI Control Word Index This value is the Control index for Control word access. Range is from 0x00 to 0x7.</p>
3:2	/	/	/
1:0	R/W	0x0	<p>CWII Control Word Internal Index 0 – Odd Control Word Low 32-bit, OCW[31:0]; 1 – Odd Control Word High 32-bit, OCW[63:32]; 2 – Even Control Word Low 32-bit, ECW[31:0]; 3 – Even Control Word High 32-bit, ECW[63:0];</p>

7.10.4.38. TSD Control Word Register(Default Value: 0x00000000)

Offset: TSD+0x20			Register Name: TSD_CWR
Bit	R/W	Default/Hex	Description
31:0	R/W	0x0	<p>CWD Content of Control Word corresponding to the TSD_CWIR value</p>

Appendix

Control signal and data port mapping for TCON:

I/O	SYNC RGB					CPU cmd	CPU 18bit	CPU 16bit								CPU 8bit			CPU 9bit	LVDS							
	Para RGB	Serial RGB			OCIP 656	256K	256K								65K	256K			65K		256K		Single Link				
		1 st	2 nd	3 rd	1 st		2 nd	3 rd	1 st	2 nd	1 st	2 nd	1 st	2 nd		3 rd	1 st	2 nd	1 st	2 nd							
IO0	VSYNC						CS														D3N						
IO1	HSYNC						RD														D3P						
IO2	DCLK						WR														CKP						
IO3	DE						RS														CKN						
D23	R7					D23	R5	R5	B5	G5	R5		R5	B5	R4											D2N	
D22	R6					D22	R4	R4	B4	G4	R4		R4	B4	R3												D2P
D21	R5					D21	R3	R3	B3	G3	R3		R3	B3	R2												D1N
D20	R4					D20	R2	R2	B2	G2	R2		R2	B2	R1												D1P
D19	R3					D19	R1	R1	B1	G1	R1		R1	B1	R0												D0N
D18	R2					D18	R0	R0	B0	G0	R0		R0	B0	G5												D0P
D17	R1					D17																					
D16	R0					D16																					
D15	G7					D15	G5								G4												
D14	G6					D14	G4								G3												
D13	G5					D13	G3																				
D12	G4	D17	D27	D37	D7	D12	G2	G5	R5	B5	G5	B5	G5		G2	R5	G5	B5	R4	G2	R5	G2					
D11	G3	D16	D26	D36	D6	D11	G1	G4	R4	B4	G4	B4	G4		G1	R4	G4	B4	R3	G1	R4	G1					
D10	G2	D15	D25	D35	D5	D10	G0	G3	R3	B3	G3	B3	G3		G0	R3	G3	B3	R2	G0	R3	G0					
D9	G1					D9																					
D8	G0					D8																					
D7	B7	D14	D24	D34	D4	D7	B5	G2	R2	B2	G2	B2	G2		B4	R2	G2	B2	R1	B4	R2	B5					
D6	B6	D13	D23	D33	D3	D6	B4	G1	R1	B1	G1	B1	G1		B3	R1	G1	B1	R0	B3	R1	B4					
D5	B5	D12	D22	D32	D2	D5	B3	G0	R0	B0	G0	B0	G0		B2	R0	G0	B0	G5	B2	R0	B3					
D4	B4	D11	D21	D31	D1	D4	B2								B1				G4	B1	G5	B2					
D3	B3	D10	D20	D30	D0	D3	B1								B0				G3	B0	G4	B1					
D2	B2					D2	B0														G3	B0					
D1	B1					D1																					
D0	B0					D0																					